

OIL RETURN  
PLUMBING ASSEMBLIES  
& COMPONENTS

Manifold assembly for all H214, 314 and 414 fryers manufactured after 9/99.  
Multiple-battery fryers of five or more require a special one-piece manifold

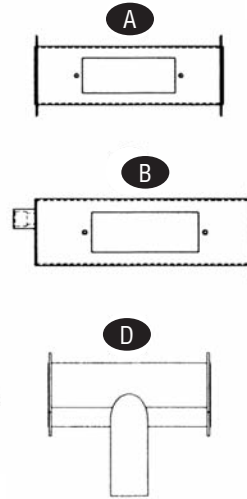

DRAIN SYSTEM  
COMPONENTS

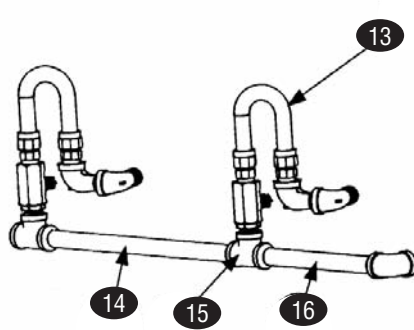
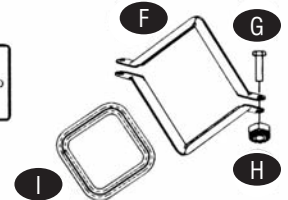
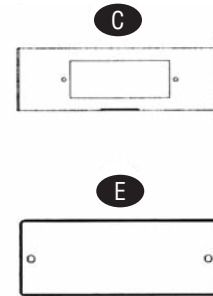

Manifold components for all H214, 314, 414 and 514 fryers  
manufactured before 9/99.

KEY	PART #	DESCRIPTION	KEY	PART #	DESCRIPTION
1	FM106-0002SP	Flex Line Assembly w/Male/Female Ends	A	FM823-0718	Drain Tube, Left End, 8"L
2	FM813-0062	Elbow, 90°, 1/2"	B	FM823-2637	Drain Tube, Left End, Full Vat
3	FM813-0469	Cap, Pipe, 1/2"	C	FM823-1549	Drain Tube, Right End, Full Vat
4	FM106-0054SP	Flex Line Assembly w/Female Ends	n/s	FM823-1508	Drain Tube, Right End, Full Vat, 15-1/2"
5	FM813-0165	Elbow, Street, 90°, 1/2x1/2"	n/s	FM823-0717	Drain Tube, Standard Cabinet, FM, 15-1/2"
6	FM810-0278	Valve, Oil Return, w/out Handle, 1/2"	n/s	FM823-0720	Elbow, Drain-EF, Right Filter Magic
7	FM813-0022	Nipple, 1/2" Close NPT	n/s	FM823-0721	Elbow, Drain-EF, Left FM
8	FM813-0265	Nipple, 1/2x1/2" NPT	D	FM823-2336	Drain, Square FootPrint
9	FM807-2484	Valve, Solenoid, 1/4" NPT, 24V	E	FM826-1348	Cover, Drain Cleanout, pkg of 5
n/s	FM826-1720	Tube, Teflon Vent, 3/8"ODx2'	n/s	FM816-0021	Gasket, Drain Cover
10	FM810-1372	Fitting, 90°, 1/4" NPTx3/8" Tube (incl Ferrule & Endnut)	n/s	FM826-1382	Wingnut, Drain Cover, pkg of 10
11	FM806-9439SP	Flex Line Assembly, 14", w/Male/Female Ends	n/s	FM816-0092	Grommet, Drain, 1"
12	FM810-1517	Manifold, Oil Return, RF H314/17/22	n/s	FM826-1345	Washer, Drain Nut, pkg of 25
n/s	FM810-1516	Manifold, Oil Return, RF H214/17/22	n/s	FM809-0347	Nut, Drain, Retainer
n/s	FM810-1518	Manifold, Oil Return, RF H414/17/22	F	FM810-0396	Clamp, Drain, 2-1/2", FM (2 required per union)
13	FM810-1067	Flex Line, Oil Return, 8-1/2"	G	FM826-1375	Screw, Hex Trim HD, S/S, #10-32x3/4", pkg of 5
14	FM813-0509	Nipple, 1/2x14-1/2" NPT	H	FM826-1376	Nut, #10-32, pkg of 10
15	FM813-0003	Tee, 1/2x1/2x1/2"	I	FM816-0032	Gasket, Square Drain
16	FM813-0275	Nipple, 1/2"x9" NPT			
n/s	FM813-0093	Nipple, 1/2"x4" NPT			