

FULL VAT 1-1/4" DRAIN ASSEMBLIES

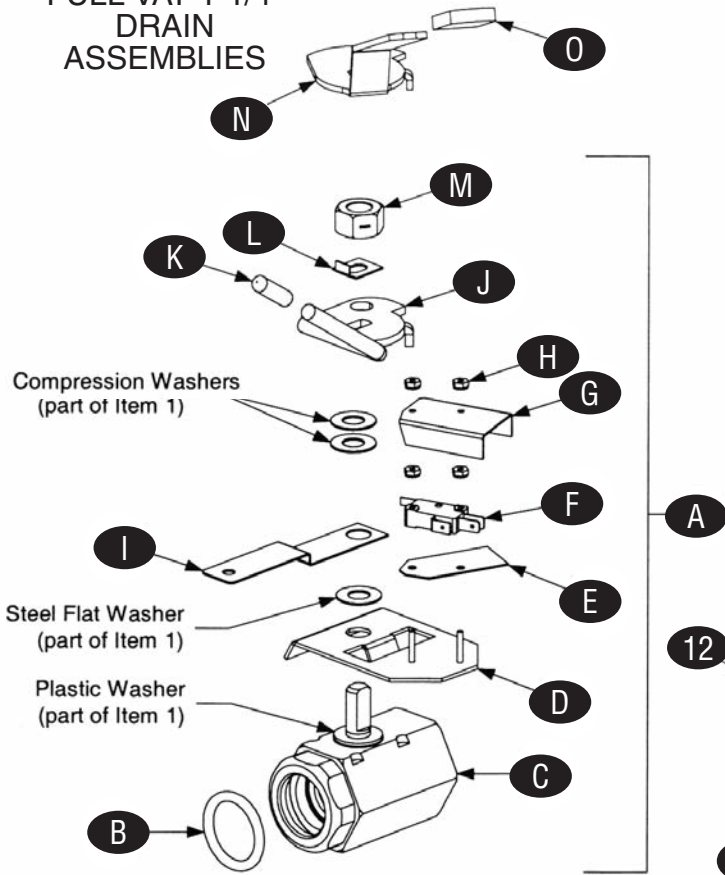

NOTE: Compression washers must be turned face to face and lock nut (Item 13) must be torqued to 80 ± 10 inch-pounds.

FRYERS

1-1/4" FULL VAT FOR UNITS BUILT BEFORE 3/1/01

NOTES: Compression washers must be turned face to face and lock nut (Item 5) must be torqued to 80 ± 10 inch-pounds.

Item 11 does not come with assembly 806-8791SP.

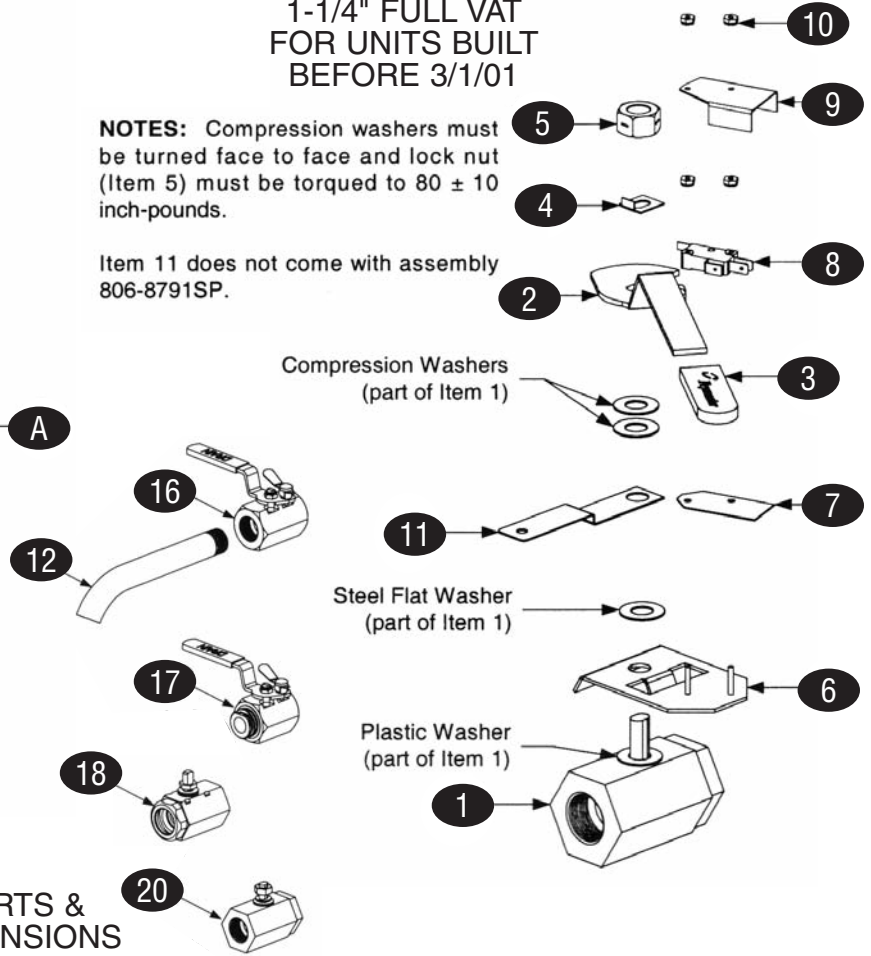

PARTS & EXTENSIONS

KEY	PART #	DESCRIPTION	KEY	PART #	DESCRIPTION
A	FM806-6373SP	Complete Assembly	0	FM814-0047	Sleeve, Valve Handle, Red, used w/#14 & Flat design #10 — UNITS BUILT BEFORE 3/1/01 —
B	FM816-0135	O-Ring, Drain Valve, 1-1/4"ID	1	FM810-1020	Drain Valve, 1-1/4" NPT Inlet, 1" NPT Outlet
C	FM810-1018	Drain Valve, 1-1/4" NPT Inlet, 1" O-Ring Outlet, 1/2" Stem, FullVat	2	FM900-2521	Handle, Drain Valve
D	FM806-8137	Bracket, Drain Valve, Microswitch	3	FM814-0047	Sleeve, Red Valve Handle
E	FM816-0220	Insulation, RF Switch	4	FM900-2936	Retainer, 1/2" Nut
F	FM807-2103	Microswitch	5	FM809-0540	Nut, 2-way Lock, 1/2"-13
G	FM900-2841	Cover, Drain Safety Switch used w/806-6373SP	6	FM806-8137	Bracket, Drain Valve Microswitch
	FM901-2348	Cover, Drain Safety Switch, replaces 900-2841 in 806-6610SP	7	FM816-0220	Insulation, RF Switch
H	FM826-1366	Nut, Keps, 4-40, w/External Teeth	8	FM807-2103	Microswitch, Lever Activated
I	FM900-2354	Bracket, Drain Valve, 1-1/4"	9	FM900-2841	Cover, Drain Safety Switch
J	FM900-2609	Handle, Drain Valve, used w/806-6373SP, design changed from Rod to Flat	10	FM826-1366	Nut, Keps, 4-40, w/external teeth
K	FM810-0677	Grip, Plastic Handle, used only with old Rod design Handle	11	FM900-2354	Bracket, Full Vat Drain Valve — PARTS & EXTENSIONS —
L	FM900-2936	Retainer, FV Drain Valve Nut	12	FM812-1226	Drain Valve Extension, Screw-In FV, 1-1/4" NPT
M	FM809-0540	Nut, 2-Way Lock, 1/2"-13, replaces Nut that comes w/810-1018	16	FM810-1569	Drain Valve w/Handle, Inlet & Outlet, FV, 1-1/4" NPT
N	FM900-2609	Handle, Drain Valve, replaces #10 in 806-6610SP	17	FM810-2535	Drain Valve w/Handle, Inlet, Bayonet Outlet, Non-Filter, Full Vat, 1-1/4" NPT
			18	FM810-1018	Drain Valve, Inlet, 1-1/4" NPT, 1" O-Ring Outlet, 1/2" Stem, Full Vat
			20	FM810-1020	Drain Valve, Inlet, 1-1/4" NPT, 1" NPT Outlet, FV