

refrigeration

MODEL #NM950

HAGAR

WATER COOLED UNITS

SCOTSMAN

Ice Systems The World Relies On.™

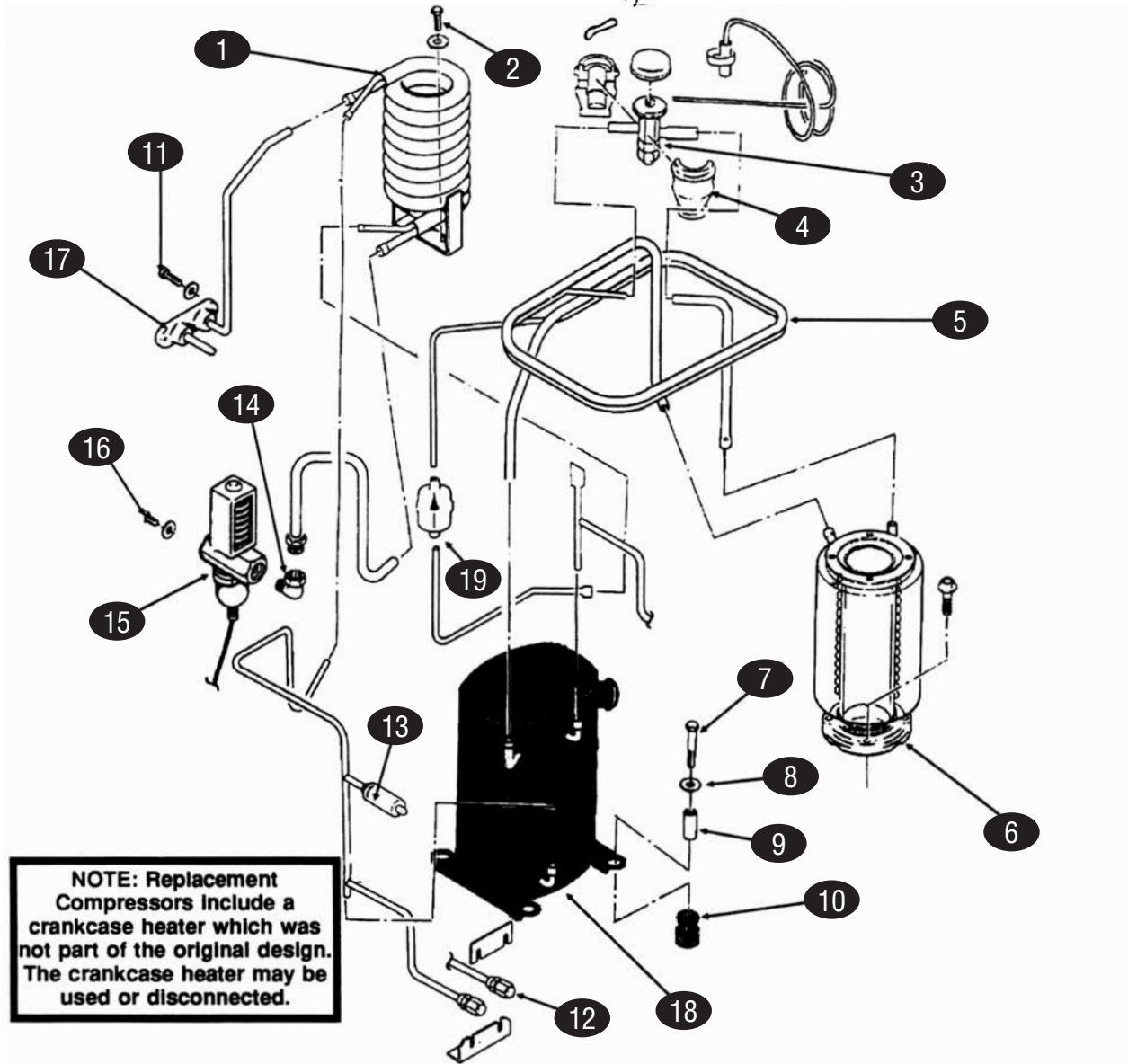

NOTE: Replacement Compressors include a crankcase heater which was not part of the original design. The crankcase heater may be used or disconnected.

KEY	PART #	DESCRIPTION	KEY	PART #	DESCRIPTION
1	SCT18-6900-01	Condenser	15	SCT11-0424-01	Water Regulation Valve
2	SCT03-1645-01	Screw	16	SCT03-1403-14	Screw
3	SCT16-0780-01	Thermo Expansion Valve	17	SCTA34044-001	Drain Assembly
4	SCTA32961-020	Insulation Kit, 3pc	18	SCT18-8000-04	Compressor, 1-Phase
5	SCTA34050-001	Suction Line		SCT18-8000-05	Compressor, 3-Phase
6	SCTA32890-020	Evaporator			(both of the above are 208-230V, have internal overloads & crankcase heaters)
7	SCT03-1405-20	Cap Screw	19	SCT02-2426-02	Dryer
8	SCT03-1407-07	Washer			
9	SCT18-2300-26	Sleeve			
10	SCT18-6800-01	Grommet			
11	SCT13-1645-01	Screw			
12	SCT16-0560-00	Valve Core			
n/s	SCT16-0563-00	Valve Cap			
13	SCT11-0446-23	Hi Pressure Cut Out			
14	SCT16-0401-02	Elbow			

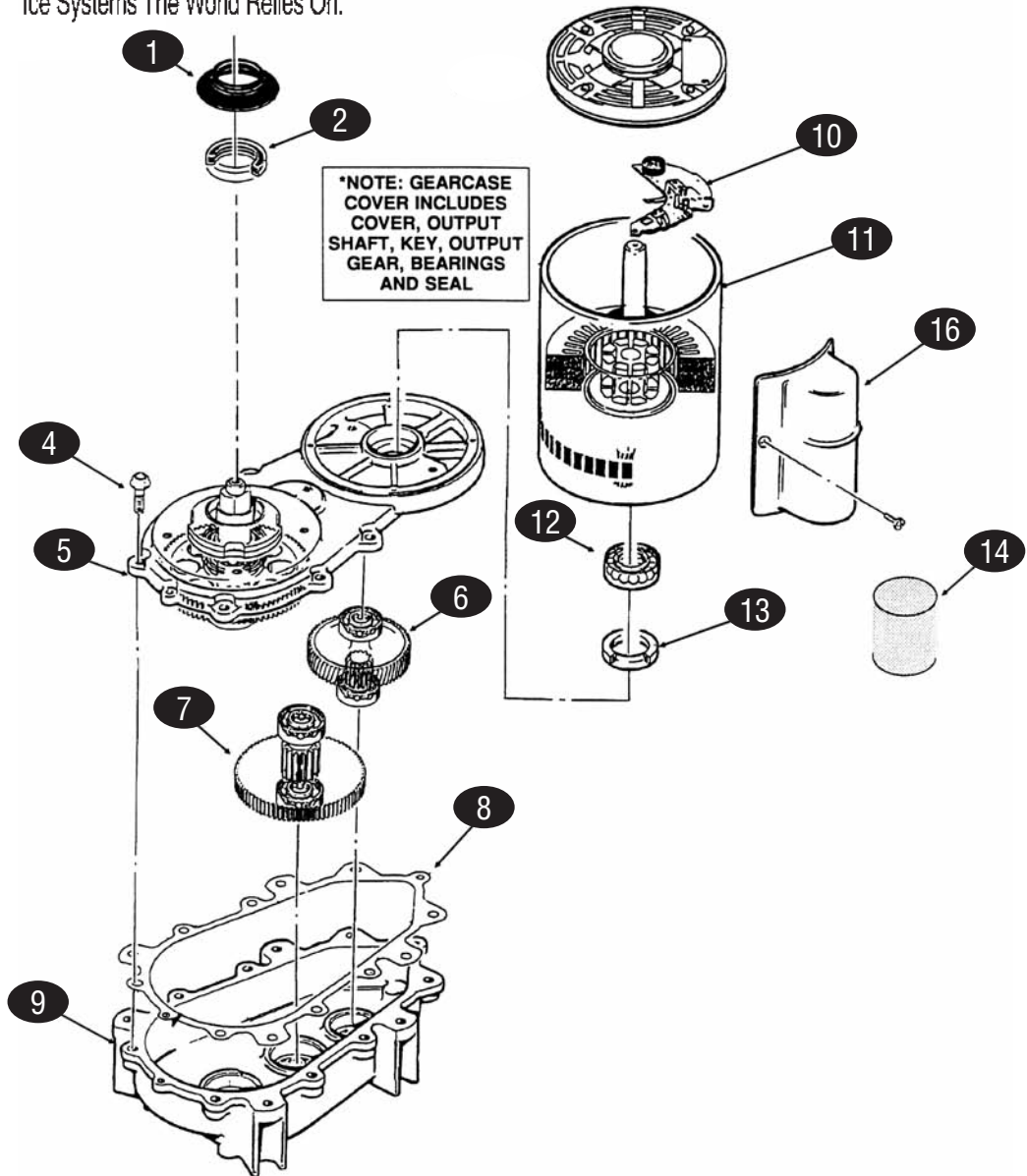

KEY	PART #	DESCRIPTION	KEY	PART #	DESCRIPTION
1	SCT13-0868-01	Water Shed	16	SCTA33220-022	Complete Assembly, 208-230V
2	SCTA32379-029	Seal	n/s	SCTA33220-030	Gear Reducer, w/out Motor
4	SCTA32379-026	Bolt			
5	SCTA32379-022	Gearcase Cover, kit includes cover, output shaft & output gear, key, bearings & seal			
6	SCTA32379-024	1st Gear & Bearings			
7	SCTA32379-023	2nd Gear & Bearings			
8	SCTA32379-021	Gasket			
9	SCTA32379-020	Gearcase			
10	SCTA32898-020	Centrifugal Switch			
11	SCTA32898-022	Drive Motor			
12	SCTA32898-030	Rotor Bearing			
13	SCTA32379-028	Seal			
14	SCTA32379-027	Oil, 1 Container			
15	SCTA32898-031	Capacitor			

refrigeration

MODEL #NM950, cont.

HAGAR

EVAPORATOR

SCOTSMAN

Ice Systems The World Relies On.™

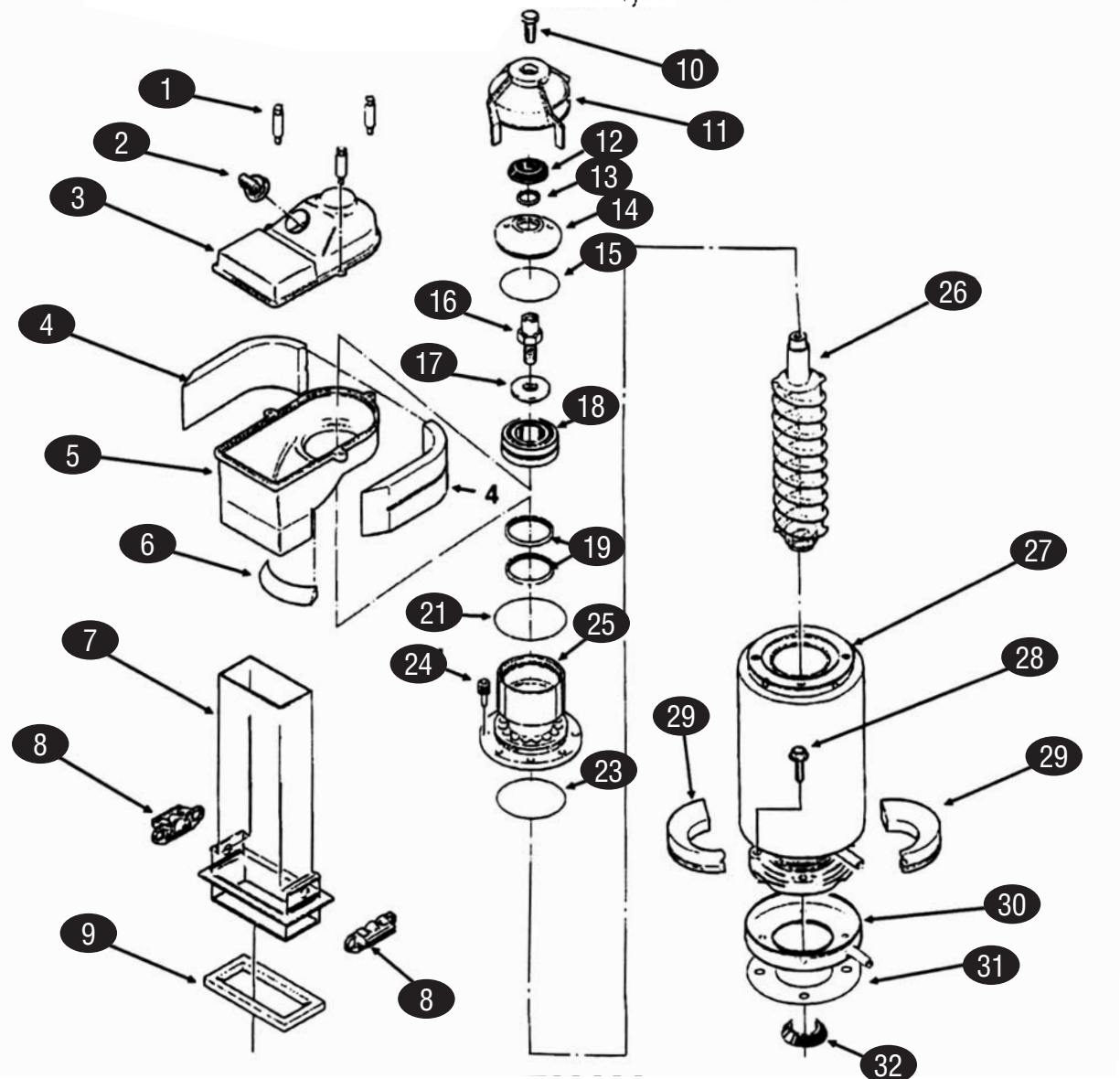

KEY	PART #	DESCRIPTION	KEY	PART #	DESCRIPTION
1	SCT02-2933-01	Hex Stud	15	SCT13-0617-54	O-Ring
2	SCTA32891-001	Switch & Housing	16	SCT08-0653-01	Auger Stud
3	SCT02-2930-01	Ice Chute Cover	17	SCT08-0654-01	Thrust Washer
4	SCTA32963-001	Insulation Top, Half	18	SCTA34559-020	Bearing
5	SCT02-2926-01	Ice Chute Body	19	SCT02-2977-01	Lip Seal
6	SCTA33102-001	Insulation Collar, Inside	21	SCT13-0617-52	O-Ring
n/s	SCTA33210-001	Rubber Band	23	SCT13-0617-45	O-Ring
7	SCT02-2929-02	Ice Chute, Lower	24	SCT03-1544-08	Socket Head Screw
8	SCTA33117-020	Bin Controls Assembly, Set of 2	25	SCTA32900-020	Breaker, (incl #18 & #19 above)
9	SCTA32930-001	Chute Gasket	26	SCT02-3003-01	Auger
10	SCT03-1405-52	Hex Cap Screw	25	SCTA33194-020	Evaporator
11	SCT02-3001-01	Ice Sweep	28	SCT03-1420-03	Cap Screw
12	SCT13-0871-01	Water Shed	29	SCTA32962-001	Insulation Bottom, Half
13	SCT02-2978-01	Lip Seal	30	SCTA32050-001	Drip Pan
14	SCT08-0650-01	Breaker Cover	31	SCT13-0704-00	Drip Pan Gasket
			32	SCT13-0868-01	Water Shed

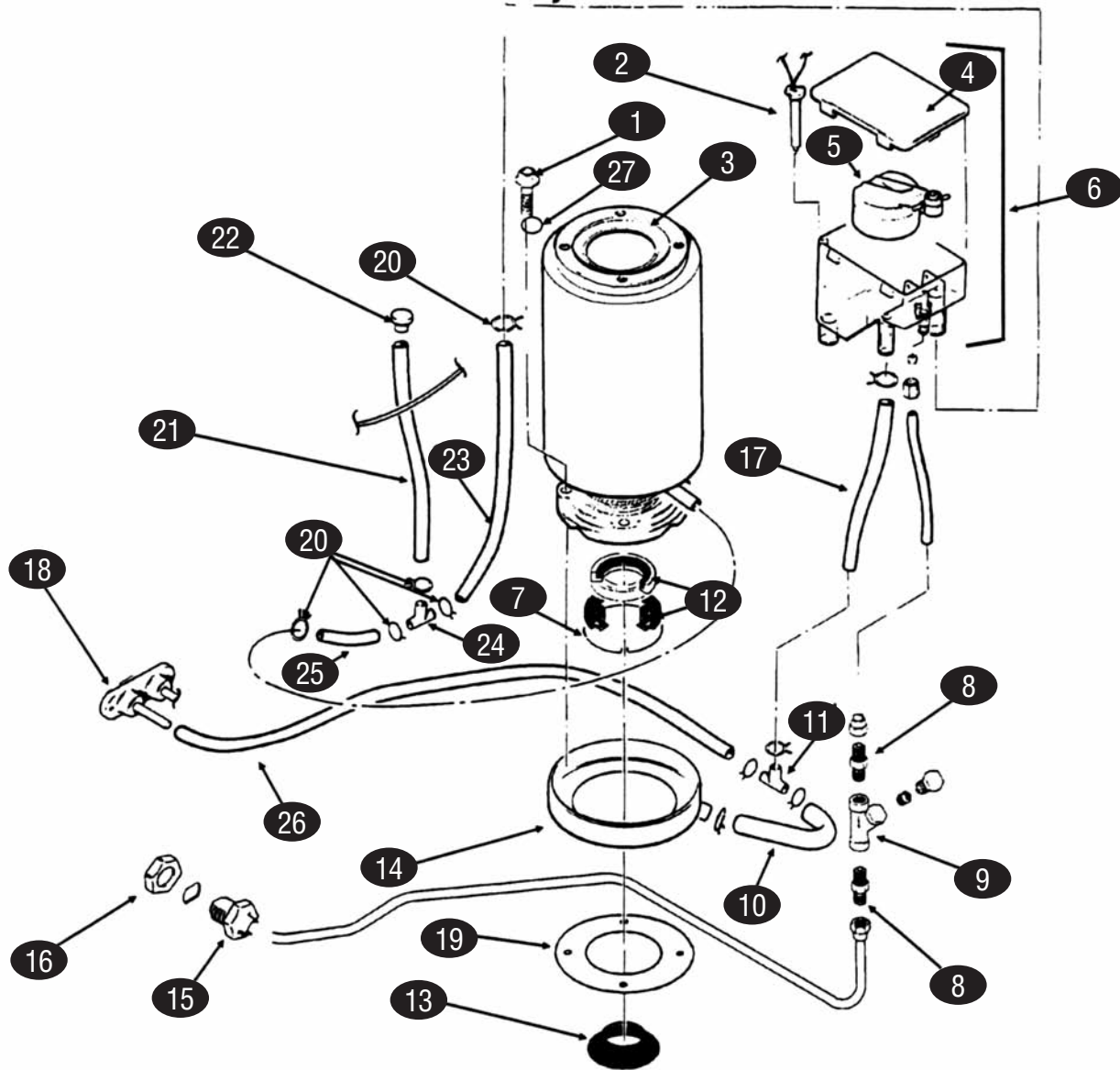

KEY	PART #	DESCRIPTION	KEY	PART #	DESCRIPTION
1	SCT03-1420-03	Cap Screw	16	SCT03-1394-01	Pal Nut
2	SCTA33101-021	Water Level Sensor	17	SCT13-0079-03	Reservoir Overflow, 8"
3	SCTA33194-020	Evaporator	18	SCTA34045-001	Drain Casting, Air Cooled
4	SCT02-2936-01	Reservoir Cover	19	SCT13-0704-00	Gasket
5	SCTA32922-020	Float Assembly w/Pin	20	SCT02-2814-08	Clamps
6	SCTA32929-020	Reservoir Assembly, Complete, incl #4 & #5 above	21	SCT13-0674-06	Evaporator Drain, 14"
7	SCTA32777-001	Retaining Ring for Seal	22	SCTA33205-001	Plug
8	SCT16-0791-01	Half Union	23	SCT13-0674-06	Evaporator Inlet Tube, 5"
9	SCT16-0162-00	Strainer	24	SCT16-0670-01	Tee
10	SCT13-0079-03	Tube, 3.2"	25	SCTA33203-001	Tube, Preformed
11	SCT16-0670-02	Tee	26	SCT13-0079-03	Drain Tube, 24"
12	SCT02-0929-02	Water Seal	27	SCT03-1417-13	Lock Washer
13	SCT13-0868-01	Water Shed			
14	SCTA32050-001	Drip Pan			
15	SCTA27318-001	Water Inlet Fitting			