



**REPLACEMENT PARTS CATALOG**

**AT-30  
CONVEYOR TOASTERS**

**AT-30 P/N 83910 - 208V, 60HZ**  
**AT-30 P/N 83912 - 208V/240V, 60HZ**  
**AT-30 P/N 83914 - 240V, 50HZ**  
**AT-30BT P/N 83915 - 240V, 60HZ**

**3 INCH OPENING**

**AT-30 P/N 83981 - 120V, 60HZ TOP HEAT**  
**AT-30 P/N 83935 - 208V, 60HZ**  
**AT-30 P/N 83934 - 240V, 60HZ**  
**AT-30 P/N 83918 - 208V, 60HZ**  
**AT-30 P/N 83980 - 240V, 60HZ**



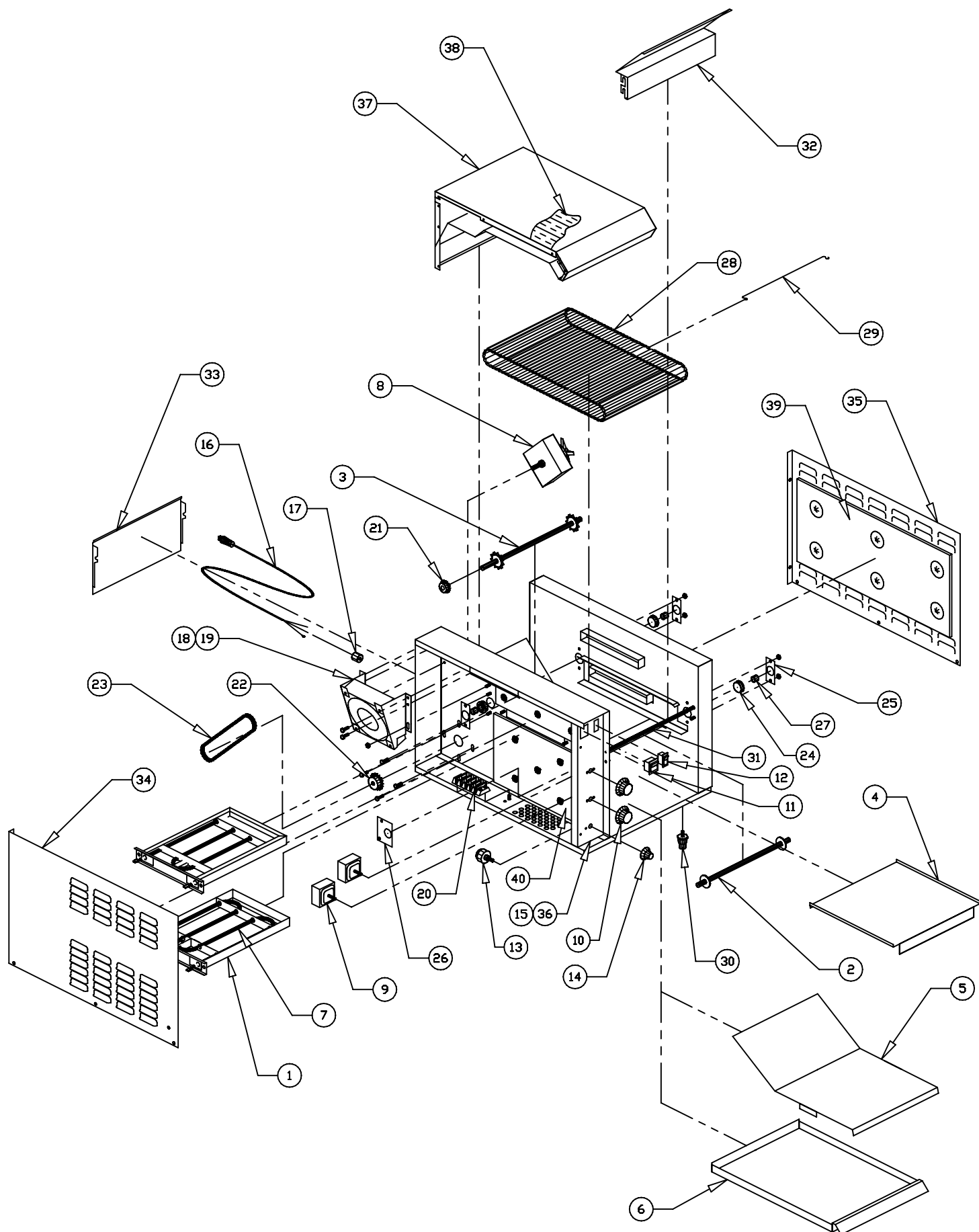

# AT-30 WIRING DIAGRAM

AMERICAN PERMANENT WARE, INC.  
729 THIRD AVENUE  
DALLAS, TX. 75226

