



729 Third Avenue
Dallas, TX 75226

M-95

Conveyor Grill Toasters

Phone: (214) 421-7366
 Fax: (214) 565-0976
 Toll Free: (800) 527-2100
 Website: www.apwwyott.com
 E-mail: info@apwwyott.com

REPLACEMENT PARTS CATALOG & WIRING DIAGRAM

TWO BUN MODELS

Model	Voltage	Watts	Hertz
M-95-2	120V	1800W	60HZ
M-95-2	208V	2780W	60HZ
M-95-2	240V	2780W	60HZ
M-95-2	240V	2780W	50HZ

THREE BUN MODELS

Model	Voltage	Watts	Hertz
M-95-3	120V	1800W	60HZ
M-95-3	208V	2780W	60HZ
M-95-3	240V	2780W	60HZ
M-95-3	240V	2780W	50HZ

ADD ONE OF THE FOLLOWING SUFFIXES AFTER THE MODEL NUMBER TO ESTABLISH THE COMPLETE PART NUMBER WITH OPTION DESIGNATIONS.

Model	Voltage/Hz	Speed
M952 M953	A=120V, 60HZ B=120V, 50HZ C=200-208V, 60HZ D=200-208V, 50HZ E=220-240V, 60HZ F=220-240V, 50HZ	A=22 SECONDS B=45 SECONDS C=35 SECONDS D=55 SECONDS E=85 SECONDS

EXAMPLE: P/N M953CC, WHICH IS M-95-3, 208 VOLT 35 SECOND GEARS. PART NUMBER MAY BE FOLLOWED BY ADDITIONAL DIGITS THAT DENOTE SPECIAL CONSTRUCTION FEATURES.



Item	P/N	Description	Item	P/N	Description
1	84110	M95-2 Base Assembly		85183	Drive Gear 17T (15)
	84180	M95-3 Base Assembly		85032	Drive Gear 19T (13)
2	84115	Left Inside Panel		85047	Drive Gear 21T (11)
3	84118	Right Inside Panel		NUMBER BELOW IN () IS MATCHING DRIVE GEAR SIZE	
4	84163	M95-2 Back Brace	37	85046	Conveyor Gear 11T (21)
	84192	M95-3 Back Brace		85033	Conveyor Gear 13T (19)
5	84142	M95-2 Top Front Cover		85030	Conveyor Gear 15T (17)
	84193	M95-3 Top Front Cover		85038	Conveyor Gear 16T (16)
6	84145	M95-2 Bottom Front Cover		85043	Conveyor Gear 19T (13)
	84191	M95-3 Bottom Front Cover	38	85115	Bushing Drive Teflon
7	84149	Left Side Panel	39	84133	Right Conveyor Side
8	84146	Right Side Panel	40	84135	Left Conveyor Side
9	84124	M95-2 Grill Plate	41	89000	Bushing Bolt
	84206	M95-2 Grill No Superfeeder	42	85228	Bushing
	84209	M95-2 Grill 9" Superfeeder	43	89165	Knob
	84188	M95-3 Grill Plate	44	83725	M95-2 Lower Conveyor Rod
10	83065	Left Hanger Bracket		85119	M95-3 Lower Conveyor Rod
11	83061	Right Hanger Bracket	45	83728	M95-2 Upper Conveyor Rod
12	89408	Motor Switch		85120	M95-3 Upper Conveyor Rod
13	56530	Indicator Lamp	46	84131	M95-2 Conveyor "H" Frame
14	60352	Knob For Thermostat		85215	M95-3 Conveyor "H" Frame
15	89491	Main Power Switch	47	84129	M95-2 Chain Weight Assy
16	89145	Terminal Block		85124	M95-3 Chain Weight Assy
17	56527	Thermostat	48	85136	Chain Master Link
18	85175	Butter Roller Motor 115V/60Hz	49	84127	M95-2 Conveyor Assy Complete
	85197	Butter Roller Motor 208-230V/60Hz		84128	M95-3 Conveyor Assy Complete
	85206	Butter Roller Motor 220-240V/50Hz	50	84179	Butter Pan
19	85209	Butter Roller Motor Fan Blade	51	84195	M95-2 Butter Roller Shaft Assy
20	85178	2.0 RPM Drive Motor 115V/60Hz		85174	M95-3 Butter Roller Shaft Assy
	84109	4.6 RPM Drivemotor 208-230V/60Hz	52	85173	Butter Roller Cylinder
	84108	4.6 RPM Drive Motor 220-240V/50Hz	53	84139	Heat Transfer Plate
	85195	2.0 RPM Drive Motor 208-230V/60Hz	54	84198	Heating Element 115V
	85205	2.0 RPM Drive Motor 220-240V/50Hz		84199	Heating Element 208V
21	85209	Drive Motor Fan (Not Used On 84109)		84197	Heating Element 240V
22	85280	Cooling Fan 115V (uses Cord 85285)	55	84168	Heating Element Clamp
	85281	Cooling Fan 208-230V	56	84167	Insulation
23	85282	Fan Guard	57	84141	Heating Element Cover
24	89111	Strain Relief	58	89120	Thermostat Bulb Clamp
25	55310	Power Cord 115V	Parts Not Shown		
	85640	Power Cord 208-230V	83753		Wire Set
26	84151	Drive Motor Mount Bracket	89029		Screw For Back Panel
27	84153	Butter Roller Mount Bracket	88961		Green Ground Nut
28	84155	Side Support Angle	88993		10-32 X 3/8 Screw
29	84122	M95-2 Back Panel	88994		10-32 X 3/16 SS Set Screw
	84187	M95-3 Back Panel	89031		10-32 X 5/16 Phl SS Screw
30	84161	Control Panel	89054		6-32 KEPS Nut
31	87321	Leg (ea.) 4"	89061		10-24 Hex Nut
	87322	Leg (ea.) 2"	89071		10 Flat Washer
32	83733	M95-2 Cross Rod	89076		1/4 Internal Star Washer
	84178	M95-3 Cross Rod	89163		1/4-20 SS Jam Nut
33	83050	Butter Roller Drive Coupling	84165		Control Panel Label
34	83051	NY Liner Bushing	88923		8-32 X 1 Screw
35	84159	Butter Roller Support Bushing	89063		8-32 Hex Nut
NUMBER BELOW IN () IS MATCHING CONV. GEAR SIZE			89140		Cable Tie
36	85042	Drive Gear 13T (19)	88894		1/4-20 X 7/8 Press Stud
	85037	Drive Gear 16T (16)			

M-95 CONVEYOR TOASTER (Exploded View)

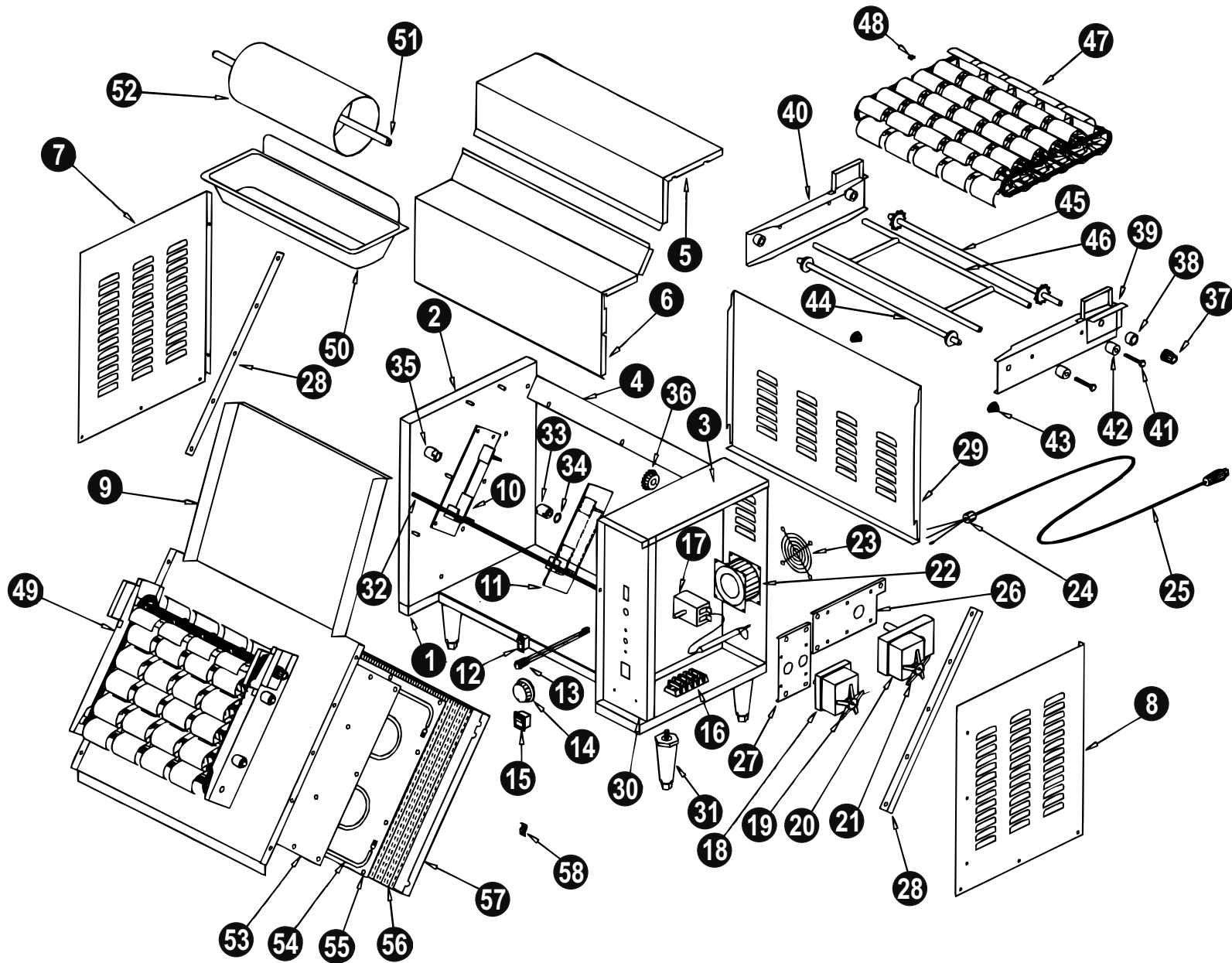

M-95 WIRING DIAGRAM

