

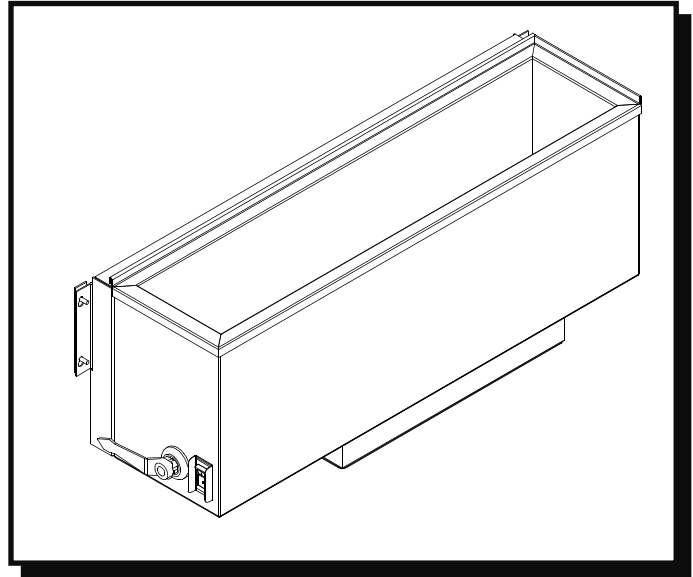

**INSTALLATION  
AND  
OPERATING  
INSTRUCTIONS**



**WENDY'S  
HOT TOPPING WARMER 4/3 x 1/2 - 4 PAN HOLDER**

Models: **W-46V**..... (120V, 1150W - Warmer w/Hanger 81000100)

**W-46V-NH**....(120V, 1150W - Warmer No Hanger 81000200)

**INTENDED FOR OTHER  
THAN HOUSEHOLD USE**

**RETAIN THIS MANUAL FOR FUTURE REFERENCE  
APPLIANCE MUST BE KEPT CLEAR OF COMBUSTIBLES AT ALL TIMES**

	<b>WARNING:</b> Improper installation, adjustment, alteration, service or maintenance can cause property damage, injury or death. Read the Installation, Operating and Maintenance Instructions thoroughly before installing or servicing this equipment.	
--	---	--

Initial heating of appliance may generate smoke or fumes and must be done in a well ventilated area. Overexposure to smoke or fumes may cause nausea or dizziness.

This equipment has been engineered to provide you with year-round dependable service when used according to the instructions in this manual and standard commercial kitchen practices.



Phone: +1 (214) 421-7366  
Fax: +1 (214) 565-0976  
Toll Free: +1 (800) 527-2100  
Website: [www.apwwyott.com](http://www.apwwyott.com)  
E-mail: [info@apwwyott.com](mailto:info@apwwyott.com)

P/N 79900002 10/07

**APW WYOTT**  
729 Third Avenue  
Dallas, TX 75226

# TABLE OF CONTENTS

<u>ITEM</u>	<u>Page</u>
<b>Owner's Information</b> .....	2
General Installation .....	2
General Operating Instructions .....	2
General Cleaning Instructions .....	2
<b>General Troubleshooting</b> .....	3
<b>Specifications</b> .....	3
Installation .....	3
Operations .....	3
Cleaning .....	3
<b>Service Information</b> .....	3
<b>Dimensions</b> .....	4
<b>Wiring Diagram</b> .....	5
<b>Parts List w/Exploded View</b> .....	6
<b>Warranty</b> .....	8

## OWNER'S INFORMATION

### General Installation

1. Always clean equipment thoroughly before first use. (See general cleaning instructions.)
2. Check rating label for your model designation & electrical rating.
3. Locate equipment on level counter and plug into a grounded outlet so that the plug is accessible. (See individual description for electrical loads.) On units bearing the CE marking the appliance must be connected by an earthing cable to all other units in the complete installation and hence to an independent earth connection.

### General Operating Instructions

1. All foodservice equipment should be operated by trained personnel.
2. Do not allow your customers to come in contact with any surface labeled "CAUTION HOT."
3. Where applicable, do not cook, warm or hold food directly in liner pans (well pans). Always use steam table pans/insets, etc.
4. Never hold food below 150°F (66°C)

### General Cleaning Instructions

1. NEVER clean any electrical unit by immersing it in water. Unplug unit before surface cleaning. **NEVER POUR COLD WATER INTO DRY HEATED UNITS.**
2. Always clean equipment thoroughly before first use. Clean unit daily. Except where noted on charts: Use warm, soapy water. Mild cleansers & PLASTIC scouring pads may be used to remove baked-on food & water scale.
3. Unplug all units before cleaning or servicing. All service should be performed by an APW authorized service agency.
4. Do not use chlorides or chloride-based products in this unit. Always clean equipment before first use. Clean unit daily. Use warm, soapy water. Rinse thoroughly to remove all residue. Chlorides, chloride-based products and improper cleaning may cause corrosion and pitting. **FAILURE TO COMPLY WITH THESE INSTRUCTIONS MAY VOID UNIT WARRANTY.**

## GENERAL TROUBLESHOOTING

### Always ask & check:

1. Is the unit plugged in?
2. Check circuit breaker.
3. Is power switch on & pilot light glowing?
4. Check rating label. Are you operating unit on proper voltage?

If the supply cord is damaged, it should only be replaced by an identical supply cord.

If the above checks out, and you still have problems, call an APW authorized service agency.

## SPECIFICATIONS

### Installation:

Follow General Instructions on previous page.

W-46V Hot Topping Warmer 4/3 X 1/2 - 4 Pan Holder.....120 volt outlet - 10 amp load.

### Operations:

Follow General Operating Instructions on previous page.

1. Add hot water (120° - 140°) to well pan: W-46V, uses 1.5 quarts (1.4 liter).
2. Turn rocker switch to "ON" position and preheat for 10 minutes.
3. Place four (4) inset pans into unit then place refrigerated toppings into inset pans.
4. Internal thermostat will automatically keep unit at correct temperature.

### Cleaning:

#### Daily Cleaning

1. Refrigerate remaining product.
2. Follow General Cleaning Instructions on previous page.

## SERVICE INFORMATION

**IF A SHORTAGE OR A PROBLEM CALL - in the USA 1-888-279-7493**

PLEASE FOLLOW THESE INSTRUCTIONS:

- A. ON ALL CALLS YOU WILL NEED TO GIVE THE FOLLOWING INFORMATION.
  1. Name and title of person calling
  2. Phone number of person calling
  3. Business name
  4. Street address
  5. City, State, Zip
  6. Model Number (from serial plate)
  7. Serial Number (from serial plate)
  8. Date purchased (if serial number indicates date of manufacture is over 13 months old you will be asked to supply proof of purchase)
  9. Purchased from

- B. FOR SHORTAGE - SUPPLY THE ABOVE INFORMATION AND FULLY EXPLAIN WHAT IS MISSING. It will be sent immediately - prepaid via UPS or equivalent. (Next Day Air or Priority shipments available at customer's expense)
- C. FOR EQUIPMENT PROBLEMS - IF WITHIN ONE YEAR FROM THE DATE OF PURCHASE THIS UNIT FAILS TO FUNCTION.  
 Contact the Authorized Service Distributor to service the equipment on site. If the problem is covered under warranty, the parts and labor will be billed to the factory.

INSTRUCTIONS AND PROCEDURES MUST BE FOLLOWED OR THE WARRANTY IS VOID.

### IMPORTANT FOR FUTURE REFERENCE

Please complete this information and retain this manual for the life of the equipment. For Warranty Service and/or Parts, this information is required.

\_\_\_\_\_  
 Model Number                      Serial Number                      Date Purchased

### W-46V & W-46V-NH HOT TOPPING WARMER - DIMENSIONS

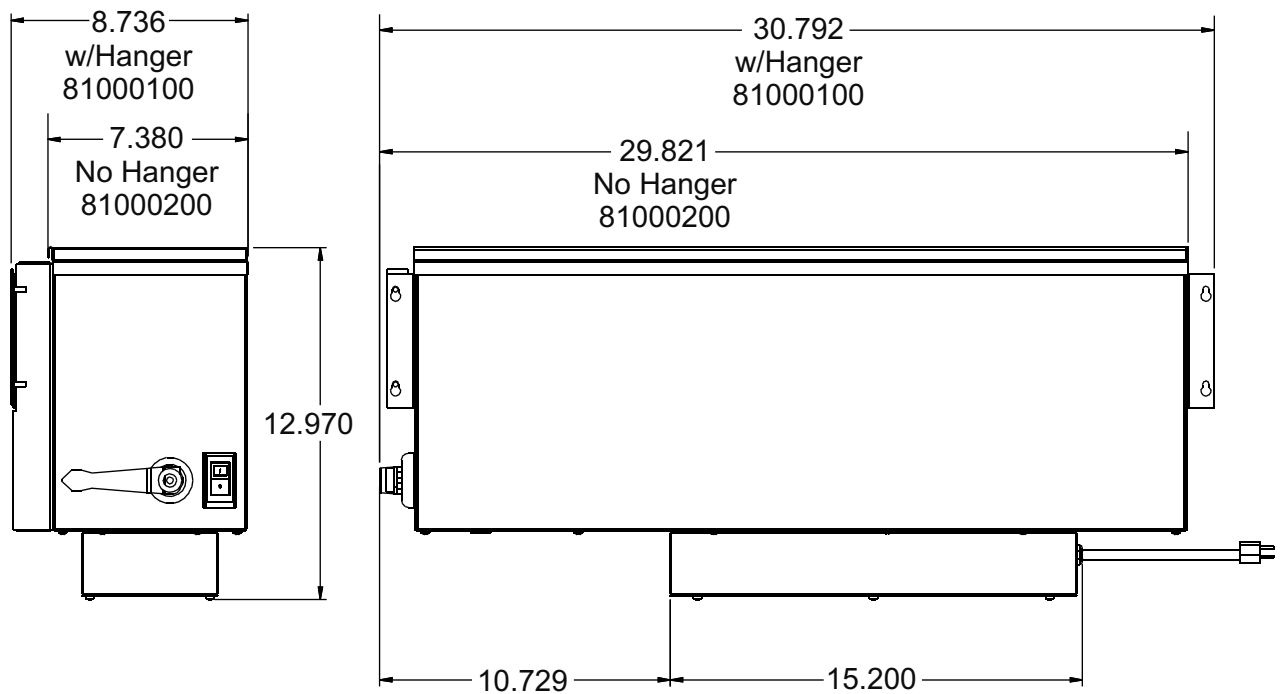

# W-46V & W-46V-NH HOT TOPPING WARMER - WIRING DIAGRAM

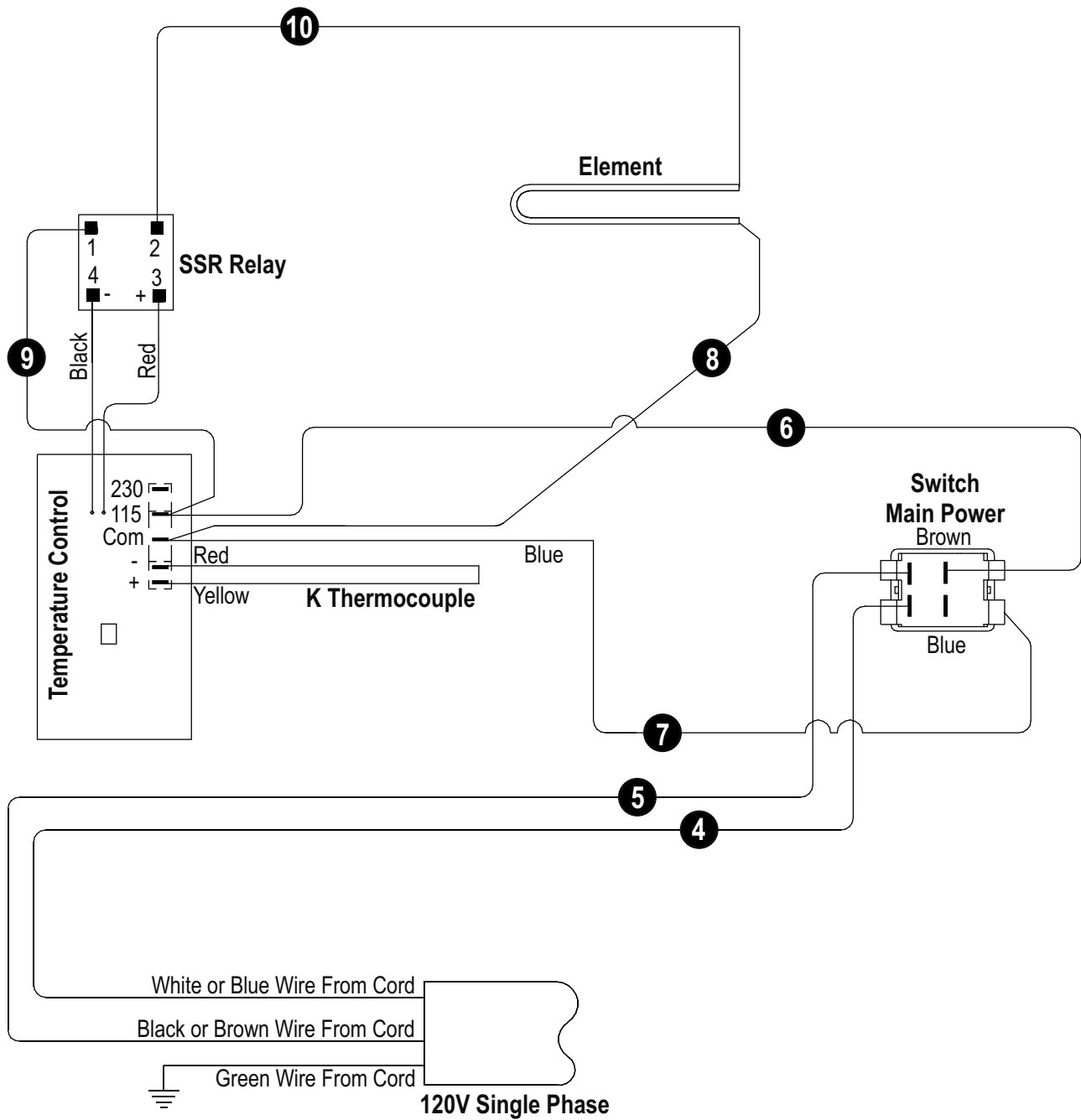

**PARTS LIST w/EXPLODED VIEW - W-46V & W-46V-NH HOT TOPPING WARMER**

ITEM	P/N	DESCRIPTION	QUANTITY
1	81000101	Weld Assembly, 1/2 x 4/3 Well w/Drain, Nipple, Studs	1
2	81000102	Wrapper Assembly	1
3	81000103	Bottom Cover	1
4	81000110	Cover, Control Panel	1
5	81000109	Bracket, Terminal Block	1
6	81000111	Bottom Cover	1
7	81000112	Mounting Bracket, 1/2 x 4/3 Warmer <i>(Used on hanger model only)</i>	1
8	81000118	Bracket, Mounting Strip <i>(Used on hanger model only)</i>	1
9	89025	Nut, Speed 10-24 Pal Zinc	14
10	70101088	Nipple, 1/2" NPT X 1.25" Brass	1
11	81000014	Valve, Drain	1
12	70444800	Switch, Rocker On-Off	1
13	81000113	Grommet, PVC, Sealing, Lip Style	1
14	89164	Screw, 1/4-20 X 5/8 Hex SI Nck PI <i>(Used on hanger model only)</i>	6
15	81000119	Heat Transfer Plate, Single Element	1
16	81000120	Element Cover, Single Element	1
17	81000114	Element, 1150W	1
18	54418	Element Cover Bracket	5
19	88933	Rivet, 1/8 X 1/4 Aluminum	10
20	89032	Screw, 10-32 x 3/8	4
21	81000122	Control, Solid State, 115/230VAC Input, 24VDC Output, 190-198° Fixed	1
22	69148	Relay, Solid State 50A 280V Out, 3-32VDC In	1
23	88948	Screw 6-32 X 3/4 Pan Hd	4
24	89050	Screw 6/32 X 1/2 Pan Hd	2
25	86284	Screw, 8-32 X 1/4 Phil Pan Type 23 Zink	18
26	81000014	Handle	1
27	85211	Housing Bearing Plated	1
28	89101	Bushing Strain Relief	1
29	55947	Cord Set	1
30	86280	Probe, "K" Thermocouple	1
31	81000121	O-Ring, 1/2 X 7/8 Buna-n #310	1
32	81000156	Bracket, On/Off Switch	1

Note: When ordering, ALWAYS specify Part #, Model #, Serial #, Voltage/Phase & type of Gas.

79900003 9/07

# W-46V HOT TOPPING WARMER - EXPLODED VIEW

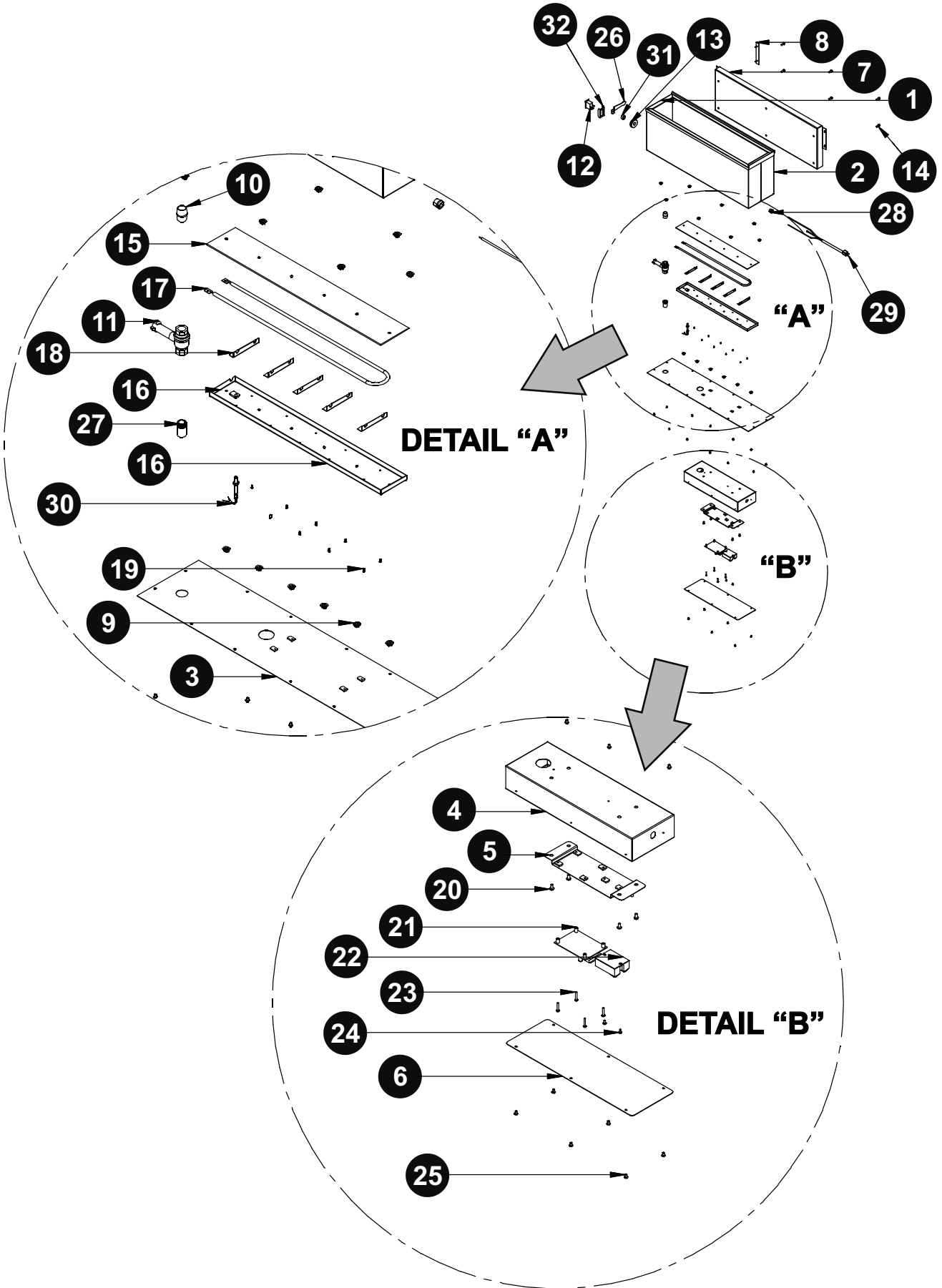

Note: When ordering, ALWAYS specify Part #, Model #, Serial #, Voltage/Phase & type of Gas.

79900003 9/07

## APW WYOTT EQUIPMENT LIMITED WARRANTY

APW Wyott Foodservice Equipment Company warrants its equipment against defects in materials and workmanship, subject to the following conditions:

This warranty applies to the original owner only and is not assignable.

Should any product fail to function in its intended manner under normal use within the limits defined in this warranty, at the option of APW Wyott such product will be repaired or replaced by APW Wyott or its Authorized Service Agency. APW Wyott will only be responsible for charges incurred or service performed by its Authorized Service Agencies. The use of other than APW Wyott Authorized Service Agencies will void this warranty and APW Wyott will not be responsible for such work or any charges associated with same. The closest APW Wyott Authorized Service Agent must be used.

This warranty covers products shipped into the 48 contiguous United States, Hawaii, metropolitan areas of Alaska and Canada. There will be no labor coverage for equipment located on any island not connected by roadway to the mainland.

Warranty coverage on products used outside the 48 contiguous United States, Hawaii, and metropolitan areas of Alaska and Canada may vary. Contact the international APW Wyott distributor, dealer, or service agency for details.

### Time Period

One year for parts and one year for labor, effective from the date of purchase by the original owner. The Authorized Service Agency may, at their option, require proof of purchase. Parts replaced under this warranty are warranted for the un-expired portion of the original product warranty only.

### Exceptions

- \***Gas/Electric Cookline:** Models GCB, GCRB, GF, GGM, GGT, CHP-H, EF, EG, EHP. Three (3) Year Warranty on all component parts, except switches and thermostats. (2 additional years on parts only. No labor on second or third year.)
- \***Broiler Briquettes, Rock Grates, Cooking Grates, Burner Shields, Fireboxes:** 90 Day Material Only. No Labor.
- \***Heat Strips:** Models FD, FDL, FDD, FDDL. Two (2) Year Warranty on element only. No labor second year.
- \***Glass Windows, Doors, Seals, Rubber Seals, Light Bulbs:** 90 Day Material Only. No Labor.

In all cases, parts covered by extended warranty will be shipped FOB the factory after the first year.

### Portable Carry In Products

Equipment weighing over 70 pounds or permanently installed will be serviced on-site as per the terms of this warranty. Equipment weighing 70 pounds or under, and which is not permanently installed, i.e. with cord and plug, is considered portable and is subject to the following warranty handling limitations. If portable equipment fails to operate in its intended manner on the first day of connection, or use, at APW Wyott's option or its Authorized Service Agency, it will be serviced on site or replaced.

From day two through the conclusion of this warranty period, portable units must be taken to or sent prepaid to the APW Wyott Authorized Service Agency for in-warranty repairs. No mileage or travel charges are allowed on portable units after the first day of use. If the customer wants on-site service, they may receive same by paying the travel and mileage charges. Exceptions to this rule: (1) countertop warmers and cookers, which are covered under the Enhanced Warranty Program, and (2) toasters or rollergrills which have in store service.

### Exclusions

The following conditions are not covered by warranty:

- \*Equipment failure relating to improper installation, improper utility connection or supply and problems due to ventilation.
- \*Equipment that has not been properly maintained, calibration of controls, adjustments, damage from improper cleaning and water damage to controls.
- \*Equipment that has not been used in an appropriate manner, or has been subject to misuse or misapplication, neglect, abuse, accident, alteration, negligence, damage during transit, delivery or installation, fire, flood, riot or act of god.
- \*Equipment that has the model number or serial number removed or altered.

If the equipment has been changed, altered, modified or repaired by other than an Authorized Service Agency during or after the warranty period, then the manufacturer shall not be liable for any damages to any person or to any property, which may result from the use of the equipment thereafter.

This warranty does not cover services performed at overtime or premium labor rates. Should service be required at times which normally involve overtime or premium labor rates, the owner shall be charged for the difference between normal service rates and such premium rates. APW Wyott does not assume any liability for extended delays in replacing or repairing any items beyond its control.

In all cases, the use of other than APW Wyott Authorized OEM Replacement Parts will void this warranty.

This equipment is intended for commercial use only. Warranty is void if equipment is installed in other than commercial application.

### Water Quality Requirements

Water supply intended for a unit that has in excess of 3.0 grains of hardness per gallon (GPG) must be treated or softened before being used. Water containing over 3.0 GPG will decrease the efficiency and reduce the operation life of the unit.

**Note: Product failure caused by liming or sediment buildup is not covered under warranty.**

**“THE FOREGOING WARRANTY IS IN LIEU OF ANY AND ALL OTHER WARRANTIES EXPRESSED OR IMPLIED INCLUDING ANY IMPLIED WARRANTY OF MERCHANTABILITY OR FITNESS FOR PARTICULAR PURPOSES AND CONSTITUTES THE ENTIRE LIABILITY OF APW WYOTT. IN NO EVENT DOES THE LIMITED WARRANTY EXTEND BEYOND THE TERMS STATED HEREIN.”**

9/05