



OPERATION MANUAL
DANTE SERIES GAS CHARBROILERS
SERIES: XX & CH



BUILT BY CRAFTSMEN. TESTED BY TIME®.



CHARBROILER OPERATION MANUAL

Models:

Dante XX & CH

Bakers Pride Oven Company, LLC is a wholly owned subsidiary of Standex International Corporation.

All gas operated Bakers Pride® charbroilers are intended for use with the type of gas specified on the rating plate and for installation will be in accordance with National Fuel Gas Code ANSI Z223.1 (latest edition).

⚠ WARNING

FOR YOUR SAFETY: Do not store or use gasoline or other flammable vapors or liquids in the vicinity of this or any other appliance.

⚠ WARNING

After the gas supply has been connected to your unit, it is extremely important to check piping for possible leaks. To do this, use soap and water solution or solutions which are expressly made for this purpose. DO NOT USE matches, candles, flames, or other sources of ignition since these methods are extremely dangerous.

Post in a prominent location instructions to be followed in the event you smell gas. Obtain these instructions from your local gas supplier.

⚠ WARNING

California Residents Only

WARNING: This product can expose you to chemicals including chromium which is known to the State of California to cause cancer and birth defects or other reproductive harm. For more information go to www.P65Warnings.ca.gov.

⚠ WARNING

Improper installation, adjustment, alteration, service or maintenance can cause property damage, injury or death. Read the installation, operating and maintenance instructions thoroughly before installing or servicing this equipment.

⚠ WARNING

Instructions must be posted in a prominent location. All safety precautions must be taken in the event the user smells gas. Safety information can be obtained from your local gas supplier.

Please retain this manual for future references.

This equipment is design engineered for commercial use only.

This equipment has been engineered to provide you with year round dependable service when used according to the instructions in this manual and standard commercial kitchen practices.



BAKERS PRIDE OVEN COMPANY, LLC.

1307 N. Watters Rd., Suite 180
Allen, TX 75013

Phone: 800.527.2100 | Fax: 914.576.0605 | www.bakerspride.com



TABLE OF CONTENTS

| | | | |
|--------------------------------------|---|--|----|
| GENERAL DESCRIPTION | 2 | OPERATIONAL GUIDELINES FOR CHARBROILER | 5 |
| INSTALLATION | 2 | NATURAL SMOKE ESSENCE | 5 |
| CLEARANCES | 2 | HELPFUL HINTS | 6 |
| GAS CONNECTION | 2 | MAINTENANCE | 6 |
| BURNERS | 2 | SERVICE | 6 |
| RADIANTS | 3 | CARE AND CLEANING OF TOP GRATES | 6 |
| TOP GRATES | 3 | GREASE COLLECTION | 6 |
| LIGHTING | 3 | CLEANING TOOLS | 6 |
| GRIDDLE PLATES | 3 | AVERAGE PRODUCTION GUIDE | 7 |
| ADDITIONAL INSTALLATION REQUIREMENTS | 4 | TROUBLESHOOTING GUIDE | 7 |
| INSTALLATION WITH CASTERS | 4 | BURNER FLAME ADJUSTMENT | 7 |
| OPTIONAL SMOKER BASE | 4 | PILOT FLAME ADJUSTMENT | 7 |
| OPERATING INSTRUCTIONS | 5 | LACK OF HEAT | 7 |
| LIGHTING PROCEDURE | 5 | ONE BURNER FAILS TO LIGHT | 8 |
| BROILING PROCEDURE | 5 | TROUBLESHOOTING CHART | 8 |
| SEASONING | 5 | VALVE ASSEMBLY VIEWS | 9 |
| STEAKS AND CHOPS | 5 | PARTS LISTS & EXPLODED VIEWS | 10 |
| HAMBURGERS | 5 | MODELS: XX-4, -6, -8, -10 & 12 | |
| THICKNESS | 5 | PARTS LISTS & EXPLODED VIEWS | 10 |
| COOKING TOOLS | 5 | MODELS: CH-6, -8, -10, -12 & 14 | |
| | | PARTS LIST & EXPLODED VIEW | 13 |
| | | WARRANTY | 15 |

SAFETY PRECAUTIONS

DANGER

This symbol warns of imminent hazard which will result in serious injury or death.

WARNING

This symbol refers to a potential hazard or unsafe practice, which could result in serious injury or death.

CAUTION

This symbol refers to a potential hazard or unsafe practice, which may result in or moderate injury or product or property damage.

NOTICE

This symbol refers to information that needs special attention or must be fully understood even though not dangerous.



INSTALLATION INSTRUCTIONS

General:

The instructions in this manual apply to all XX series and CH series Broilers.

The XX series may include the following options:

Ceramic briquettes designated by a GS Suffix on the model number.

Installation:

- (a) In USA, INSTALLATION of this broiler must conform with the latest edition of the National Fuel Gas Code, ANSI Z223.1 and/or local codes.
- (b) In CANADA, INSTALLATION must conform with the latest edition of the National Gas Installation Code, CAN/CGA-B149.1 or the Propane Installation Code, CAN/CGA-B149.2, as applicable and/or local codes.
- (c) In MASSACHUSETTS, All gas products must be installed by a "Massachusetts" licensed plumber or gas fitter. Ventilation hoods must be installed in accordance with NFPA-96, current edition, with interlocks as described in that standard.

Acceptable Clearances:

Due to intense heat generated by radiation, these broilers should be installed in non-combustible locations only including above the grate level.

Minimum Clearance From Non-Combustible Construction.

| Series | Right | Left | Back |
|--------|-------|------|------|
| XX | 0" | 0" | 0" |
| CH | 0" | 0" | 0" |

Gas Connection:

The gas pressure regulator supplied must be installed at the gas inlet of each broiler. Each regulator is adjusted to yield a manifold pressure of 5 in. water column for natural gas or 10 in. water column for propane gas. No pressure regulator is required for propane gas in Canada.

| Recommended minimum gas supply lines are listed below | | |
|---|----------------|------------------|
| All XX Models | CH-4 thru CH-8 | CH-10 thru CH-16 |
| 3/4" | 1" | 1 1/2" |

For units using propane gas, supply lines less than 1/2" inside diameter should not be used, even for a small unit.

On the XX and CH series, the gas connection is located on the right rear of the unit.

⚠ CAUTION

Be sure to cap whichever side is not connected.

NOTICE

A shut-off valve in a readily accessible location must be mounted on the gas supply line before the unit.

When making gas pipe connections, pipe joint compound resistant to the action of liquefied petroleum gases should be used.

The broiler and its individual shutoff valve must be disconnected from the gas supply piping system during any pressure testing of that system at test pressures in excess of 1/2 psig (3.45 kPa).

The broiler must be isolated from the gas supply piping system by closing its individual manual shutoff valve during any pressure testing of the gas supply piping system at test pressures equal to or less than 1/2 psig (3.45 kPa).

Burners:

Check to see that AIR MIXER CAPS on the front of all burners are tightened and adjusted, allowing half the opening to show. Install the burners and deflector shields first following the steps below.

- (a) Install all burners with deflector shield assemblies attached.
- (B) Place the front of the burner into the valve assembly by fitting the center hole of the mixer cap over the brass orifice.
- (c) Drop the rear end of the burner over the burner support pin on the back of the unit.

INSTALLATION INSTRUCTIONS

Radiants:

Mount the “V” shaped radiants over the burners with each end mounted on special supports on the front and rear of the chamber. A radiant should be mounted over each burner assembly.

GS Ceramic Briquettes Option:

The radiants supplied for the GS option are flattened to allow for the installation of an expanded metal grate. The grate is installed directly on top of the flattened radiant burner shield. Ceramic briquettes are installed on the grate as shown:

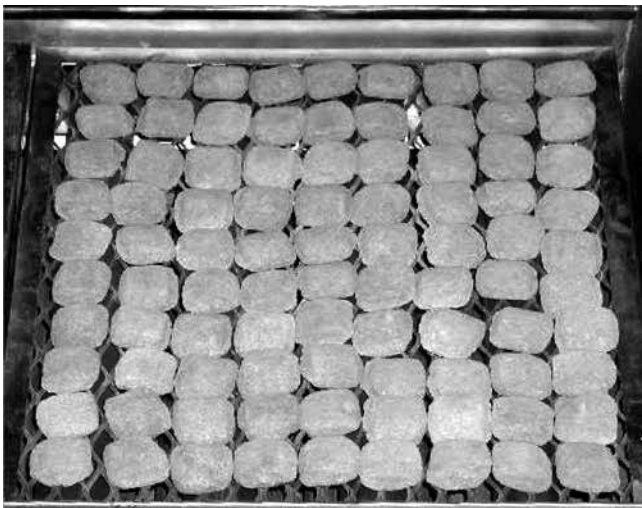

Figure 1: Typical Ceramic Briquette Installation

Top Grates:

Place a grate over each of the radiants. For normal operation, the pointed side of the grate is facing up. For use with foods that require extra support, the flat side may be used.

On XX Models, grates can be placed on three levels; two positions are built into the rear of the unit; the third position requires a special adapter. On CH models, three positions are already built into the rear of the unit.

Lighting:

Each burner on the base charbroiler has a standing pilot burner that must be lit before the burners can be lit. To light the pilot burners:

- (a) Turn all broiler valves to the off position.
- (b) Remove each top grate and radiant.
- (c) Open main gas SHUT-OFF valve (supplied by customer).
- (d) Allow air to bleed from the gas line through the pilot burners.
- (e) Light the pilot burners using a lit taper.
- (f) Turn the burner control valves “ON” to light the burners.
- (g) If any burner fails to light, turn the burner valves to “OFF”, wait five minutes and repeat the above procedure.
- (h) After all burners have been ignited properly, turn each burner valve “OFF” and allow the unit to cool. NOTE: Make sure that the pilot burners stay lit.
- (i) Replace radiants and top grates.
- (j) Each burner may now be adjusted to the desired flame size by turning the individual burner valve handle.
- (k) To shut down the unit, turn all valves “OFF”

Wait five minutes before attempting to re-light.

NOTICE

The pilot burners will stay lit until the gas supply to the unit is turned “OFF”.

Griddle Plate:

Griddle plates should not cover more than 50% of the BROILING area. Each Griddle Plate fits on top of two grates (one 4 1/2” and one 6”). It is not necessary to remove the top grates and radiants before installing the griddle plate.



INSTALLATION INSTRUCTIONS

Additional Installation Instructions

- (a) Keep the area around the broiler free and clear of combustible materials.
- (b) The provision of an adequate air supply to your broiler is essential. Provide for sufficient outside air to enter the broiling area and assure that this airflow is not obstructed.
- (c) Air enters the burner area from the front and bottom of your broiler. Assure that these areas are kept open and unobstructed.
- (d) Servicing is accomplished through the front and top of the broiler. Assure that these areas are kept unobstructed for proper servicing and operation.

Installation With Casters

- (a) Install the casters with the wheel brakes on the front of the appliance.
- (b) Installation should be made with a connector that complies with the latest edition of the Standard for Connectors for Movable Gas Appliances, ANSI Z21.69 in the USA (CAN/CGA-6.16 in Canada), and a quick disconnect device that complies with the latest edition of the Standard for Quick Disconnect Devices for use with gas fuel, ANSI Z21.41 in USA (CAN 1-6.7 in Canada) and adequate means must be provided to limit the movement of the appliance without depending upon the connector and any quick disconnect device or its associated piping to limit the appliance movement.
- (c) The restraint should be attached to the legs on which the casters are mounted.
- (d) If disconnection of the restraint is necessary, the restraint should be reconnected after the appliance has been returned to its originally installed position.

Optional Smoker Base

Installation

- (a) Remove the grease pans from their rails completely and set aside.
- (b) Unscrew to remove the legs from the broiler. Discard.
- (c) Set the broiler into the base unit. The frame will fit into the lip around the top of each side and the back.
- (d) Install the #10 self-threading sheet metal screws around the base into the broiler frame to hold in place. Each screw requires a 5/32 hole to be drilled into the broiler frame.
- (e) Get the grease pan(s) previously set aside. Insert a log holder into each pan. Slide the pan into the bottom of the base.

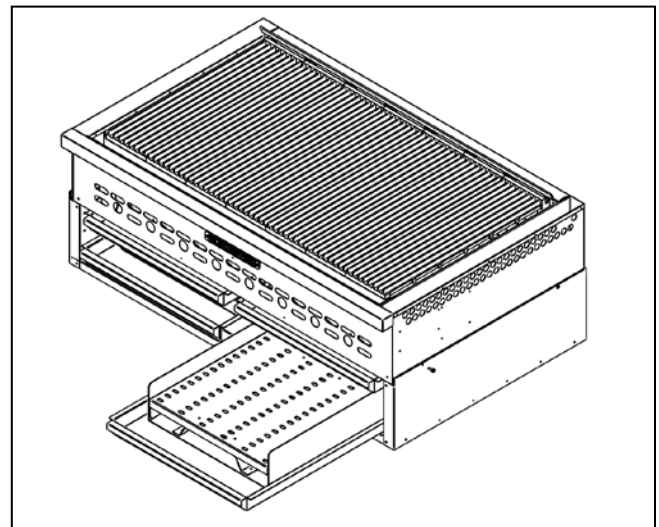



OPERATING INSTRUCTIONS

Lighting Procedure:

See INSTALLATION INSTRUCTIONS. Once the pilot burners are lit, the broiler may be turned "ON" or "OFF" by turning the control valves on or off as necessary.

Broiling Procedure:

Broiler top grates must be hot enough to make black char-marks when starting to broil.

Adequate pre-heating time is necessary for the food to release from the broiler and to cook properly. Allow the unit to pre-heat for 45 minutes to 1 hour before broiling.

(a) **Seasoning:** Marinades with oil and vinegar or wine bases are best applied at least 1 to 2 hours before broiling. Spice mixes, such as flavored salt etc., should be applied 10 to 30 minutes before broiling. Tomato and sugar based products, such as barbecue sauces etc., have a tendency to burn and should be used prior to removing the food from the broiler, or after removal.

(b) **Steak and Chops:** Cuts of meat with bones require longer cooking times at lower temperatures to reach the same internal doneness as cuts without bones. To prepare a well-done steak, trim the fat to reduce flare-up and the tendency to burn the outside.

(c) **Hamburgers:** Chopped steak, etc. **MUST NOT BE TOO LEAN.** For fat flare and smoking action in char-broiling, hamburgers should have about 25% fat content.

Fat rendered out during broiling:

- (1) Helps to release the burger from the grates.
- (2) Helps the searing action that seals meat juices inside.
- (3) Enhances the char-broil flavor by flaring-up in the form of smoke and flame.

(d) **Thickness:** During the broiling process, the hamburger contracts and becomes thicker and smaller in diameter. Pressing the hamburger out thin before broiling will compensate for the shrinkage. Broil a hamburger as you would broil a steak.

- (1) Be sure that the charbroiler has had adequate pre-heating time so that the hamburger does not stick to the broiler grate.
- (2) Place the hamburger on the grate and allow it to cook until release is attained.
- (3) Once the hamburger releases from the grate, turn it over and allow it to cook for 1 minute, then turn once a minute until the desired degree of doneness is attained.

(e) **Cooking Tools:** Bakers Pride has designed a number of tools to help you operate more efficiently including a special spatula that is very effective for fish and hamburgers. Other tools are available. Contact the factory for full details.

(f) **Operational Guidelines For CharBroiler Natural Wood Smoke Essence:** Wood Smoke assist charbroiling is more of an art than a science due to the many variables that affect wood ignition, rate of combustion, as well as personal preference.

In order to obtain the optimal results and flavor transfer the wood should smolder, not flame. Place wood in the log holders and follow the procedures recommended below and then adjust as required:

- 1) Preheat char broiler on maximum heat for 1/2 hour before adjusting for your various temperature zones.
- 2) Fill log holders to approximately 3/4 of capacity using dry or presoaked wood.
 - a) When the char broiler's burners are set to maximum flame, the wood will begin smoking. While several factors will affect the rate of combustion of the wood, such as moisture content of the wood, size of the wood, type of wood, elevation above sea level, you can generally expect smoldering to begin in approximately 35-50 minutes. However, the flavor transfer or ability to impart a smoky flavor into your food product will occur sooner, approximately 15 minutes, or as soon as the aroma of burning wood is evident.



OPERATING INSTRUCTIONS

- 3) As the wood incinerates and begins to turn to ash, it will lose its ability to impart a smoke flavor. Periodically check the condition of the wood and replenish before it is completely burned. This will ensure uninterrupted smoking capabilities throughout your service period.
- 4) If the wood flares up because of the dripping grease or oil, spray water generously, directly on the burning wood.
- 5) If the wood tends to over flare, either pre-soak wood in water, or use a combination of dry and pre-soaked wood as required to balance ignition and flare.
- 6) The amount of wood needed to complete the meal service will vary greatly depending on the size of the wood pieces and the moisture content.

⚠ CAUTION

IMPORTANT SAFETY INFORMATION: At the end of the meal service, if there is unspent wood remaining in the log holders, be sure to empty it into a sealable metal container, douse with water, stir embers, douse again, then cover with an airtight lid.

Helpful Hints:

- (a) Do not press the juice out of the meat because that will cause a dry product.
- (b) Allow the meat to sit covered on a heated platter for 2 to 5 minutes after broiling before cutting. This will allow the juices to “settle” and the product will be more moist.
- (c) Do not use forks or other sharp objects which poke holes in the meat. Do not cut the meat as it cooks.
- (d) Thick pieces of meat require a longer broiling time with less flare-up. Reduce flare-up trimming excess fat for a longer broil time without burning.
- (e) Keep the unit clean. Food caught between the grates will not allow hot air to rise around the product. This will result in uneven heating and increase cook time.

Maintenance:

- (a) **Service:** Shut off the main gas supply before attempting any maintenance on the unit. If required, contact your Dealer, the Factory, or a local Service Company to obtain qualified maintenance and repairs.
- (b) **Care And Cleaning of Top Grates:** The top grates should be cleaned using a stiff wire brush. If this is done daily, the accumulation of food and fat caught in the grates and work necessary to keep them clean will be reduced. Periodically, they should be turned over and brushed and then put back. In the event that an extra amount of fat is accumulated on the top, due to use of low heat, we recommend turning up the flame of this section for about an hour, which will burn off much of the fat and residue and the brushing operation will be easier. Under no circumstances should the grates be placed in a dishwasher. Soap, water, or any detergents should never be used on the cast iron grates.
- (c) **Grease Collection:** Your char-broiler is designed to bring grease into the front channel which in turn drains the grease into the grease collection pan in the lower section of the broiler. The pan in the lower section should be cleaned daily or more often if necessary. The channel should be cleaned periodically with a stiff brush or scraper.
- (d) **Cleaning Tools:** Several models of specially designed top grate brushes and grease drain scrapers are available from Bakers Pride. Contact Bakers Pride for more information.



OPERATING INSTRUCTIONS

Average Production Guide:

Estimated Hourly Production

| MODEL NUMBER | BROILING AREA | 3 OZ. BURGERS | 12 OZ. STEAKS |
|--------------|---------------|---------------|---------------|
| CH-4 XX-4 | 21" x 24" | 600 | 120 |
| CH-6 XX-6 | 31 1/2" x 24" | 900 | 180 |
| CH-8 XX-8 | 42" x 24" | 1200 | 240 |
| CH-10 XX-10 | 52 1/2" x 24" | 1500 | 300 |
| CH-12 | 63" x 24" | 1800 | 360 |
| CH-14 | 73 1/2" x 24" | 2100 | 420 |
| CH-16 | 84" x 24" | 2400 | 480 |

The table above gives estimated hourly production as a guide only. Actual production may vary depending on required doneness, thickness and weight of product.

TROUBLESHOOTING GUIDE

CAUTION: Take extreme care to assure that, if a valve is opened, a flame is present. If a valve is left open without a flame, turn the valve off and wait at least five minutes before attempting to (re)light. Service should be performed only by a qualified gas technician.

Burner Flame Adjustment:

- (a) The burner flame should be as blue as possible. However, there will be traces of orange and/or yellow from particles in the air burning in the flame. Slight yellow tips at the flame ends are acceptable.
- (b) If the flame appears yellow, loosen the air-mixer cap hold down screw "A" (see figs. 2 and 3). Rotate the air mixer cap counter-clockwise to allow more air into the burner, until the flame turns blue. Tighten the screw.

Pilot Flame Adjustment:

The pilot flame can be adjusted by turning the appropriate adjusting screw using a screwdriver or a 3/16 wrench (see fig. 2), counter-clockwise to increase, clockwise to decrease and close. The pilot flame should be about 1/2 inch long.

Lack Of Heat:

Check to see if the pilot flames are on. If they are on but the burners do not light, or the burner flames look weak, then there is a possibility of a gas pressure loss to the broiler.

- (a) Check that the unit's main valve is fully open. Normally in the open position, the valve handle will be parallel to the piping. The valve should be located somewhere on the gas line feeding the charbroiler. If the handle is NOT parallel to the piping, the unit is not getting the gas supply required to operate properly. Turn the valve handle parallel to the gas supply line.
- (b) If there is a problem with the gas supply, it may be checked fairly easily. Turn off half of the burners or turn off all other gas appliances and see if the broiler flames increase. If there is an increase in the flame height then there is a problem with the gas supply. A problem with the gas supply requires immediate attention. IMMEDIATELY close all the burner valves (turn to the off position), including the charbroiler's main valve. Contact a qualified service agency or the public gas company.



TROUBLESHOOTING GUIDE

The following should be checked:

1. The building's main pressure regulator.
2. The size of the broiler's gas supply line (if it is a new installation).
3. The broiler's pressure regulator.
4. The orifice size of each burner.

One Burner Fails to Light:

NOTE: Always make sure that grates, radiants and burners are cold before handling.

- (a) Check to see that the on/off valve to that burner is on.
- (b) Check to see if the pilot flame is lit. Each burner has its own pilot, which is located on the manifold along the front of the charbroiler (see Fig. 2).

If the pilot is not lit, attempt to light it using a long taper. If it fails to light, turn off all the burners, allow to cool and then remove the top grate and the radiant over the burner. With a thin wire or pin, check that the hole is clear at the top of the pilot tube. Attempt to relight using a taper.

- (c) If the pilot burner is lit, close all the burner valves, allow to cool and then remove the top grate and the radiant over the burner, and check that the pilot flame is located over the first few holes in the burner. The pilot tube can be bent slightly to reposition the flame.
- (d) If the pilot is lit, positioned correctly, and has a proper flame, close all the burner valves, allow to cool and then remove the top grate and radiant over the burner.

Remove the burner by lifting the rear of the burner off the support pin, slide it towards the rear of the broiler, enough to clear the burner orifice (fig. 3 or 4).

Using a thin wire or pin, check to see that the orifice is clear, taking care not to enlarge the hole. Replace the burner, radiant and grate and attempt to light it again.

If the burner will not light, the burner valve could be defective. Contact your dealer, the factory or a local service company.

For additional information contact: Bakers Pride Oven Co., Inc. (914) 576-0200.

Troubleshooting Chart

| PROBLEM | PROBABLE CAUSE | SOLUTION |
|--|---|--|
| Burners & pilots will not turn on | Main gas supply to broiler is not turned on. | Turn on main gas supply. |
| Burners produce excessive carbon deposits | Incorrect gas type. | Supply correct type gas. |
| | Incorrect gas supply pressure. | Call local gas supplier. |
| | Incorrect orifices. | Call Bakers Pride authorized service center. |
| | Primary air not adjusted properly. | Adjust air shutter. |
| Pilot will not remain lit | Pilot flame adjusted incorrectly. | Adjust pilot flame. |
| | Draft condition. | Remove draft. |
| | Improper ventilation system. | Call an HVAC specialist. |
| Excessive flare-up | Overload of fatty meat. | Add water to grease pan. |
| Broiler doesn't seem hot enough | Orifices may be dirty/clogged. | When unit cools, check & clean orifices. |
| | Low gas pressure. | Increase gas pressure to 5" W.C. (Nat) or 10" W.C. (L.P.) |
| | Top grates may be dirty/clogged. | When unit cools, check & clean top grates. |
| | If the ventilation is too strong it will suck heat from the cooking/broiling surface. | Call an HVAC specialist. |
| Grates &/or radiants &/or burners &/or gas valves warp | Usually improper cleaning methods ie; users cover grate top w/sheet pans & crank up heat to burn-off debris | Do not "Burn-Off" top grates. This causes the firebox area to overheat excessively. *Never Cover top grates. |

VALVE ASSEMBLY VIEWS

Valve Assembly Views:

(A=Cap Hold-Down Screw)

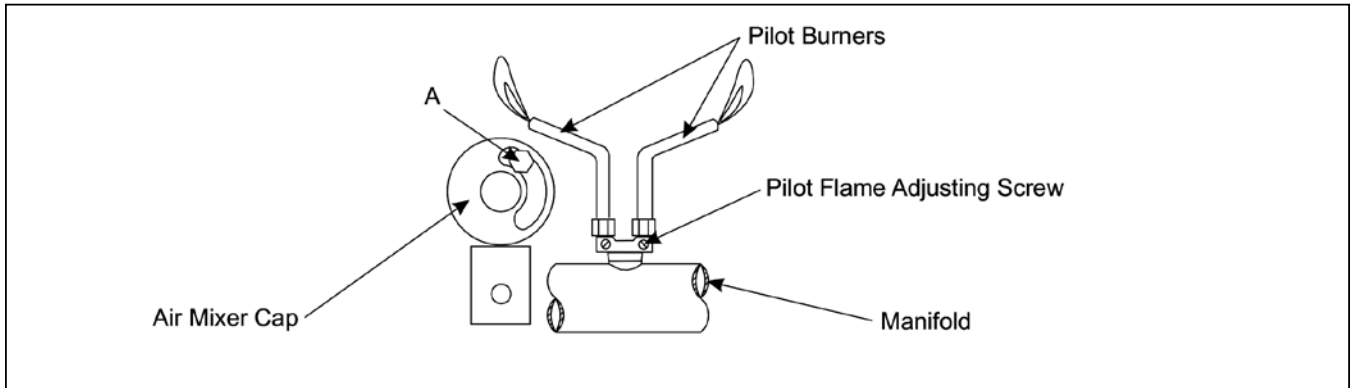

Figure 2: Air Mixer Cap And Pilot Burners

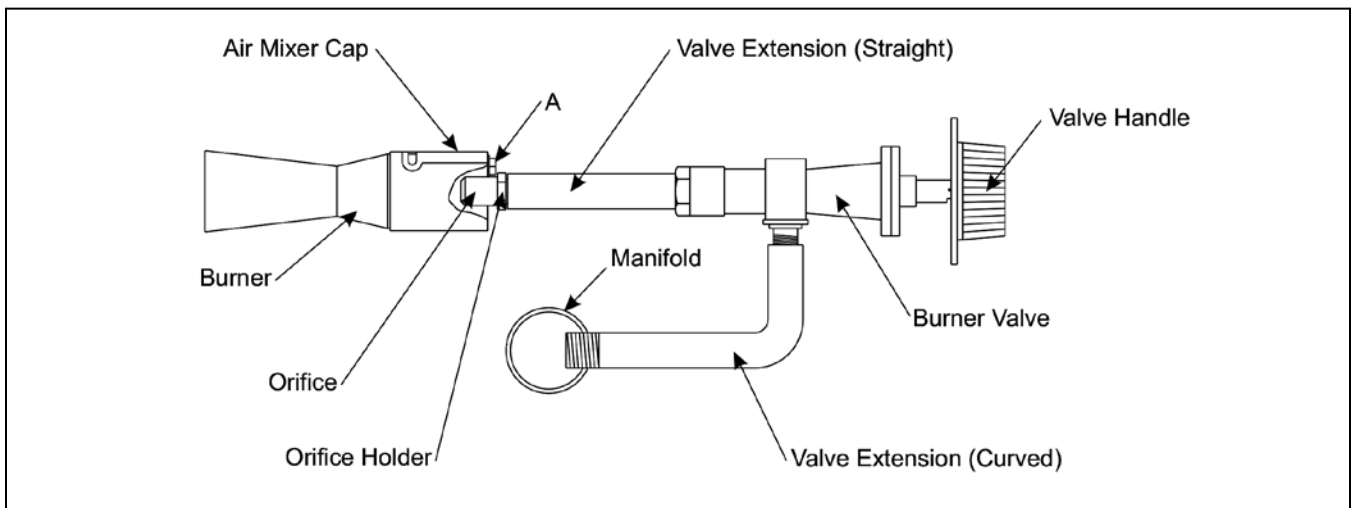

Figure 3: Side View - CH Series

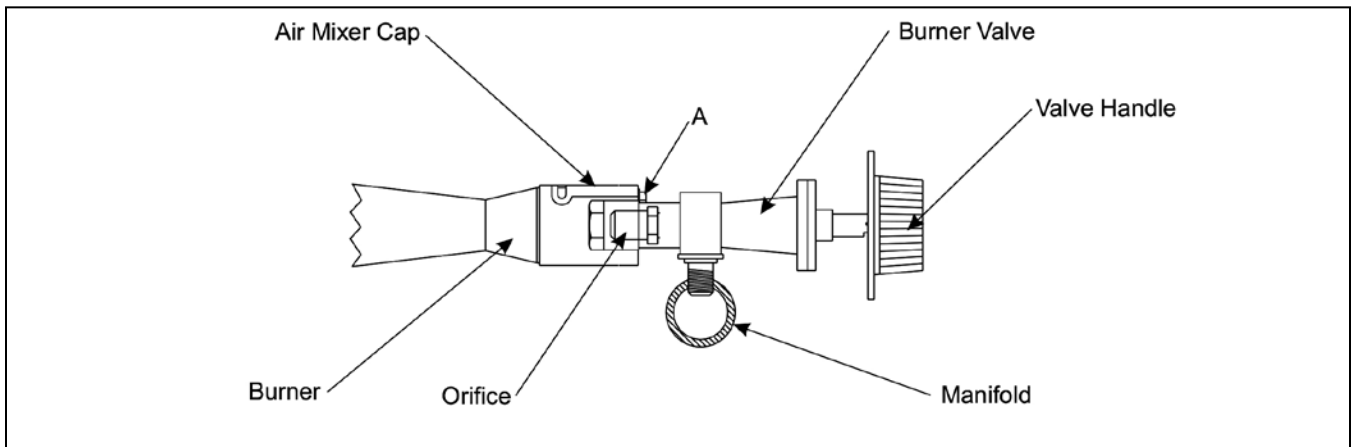
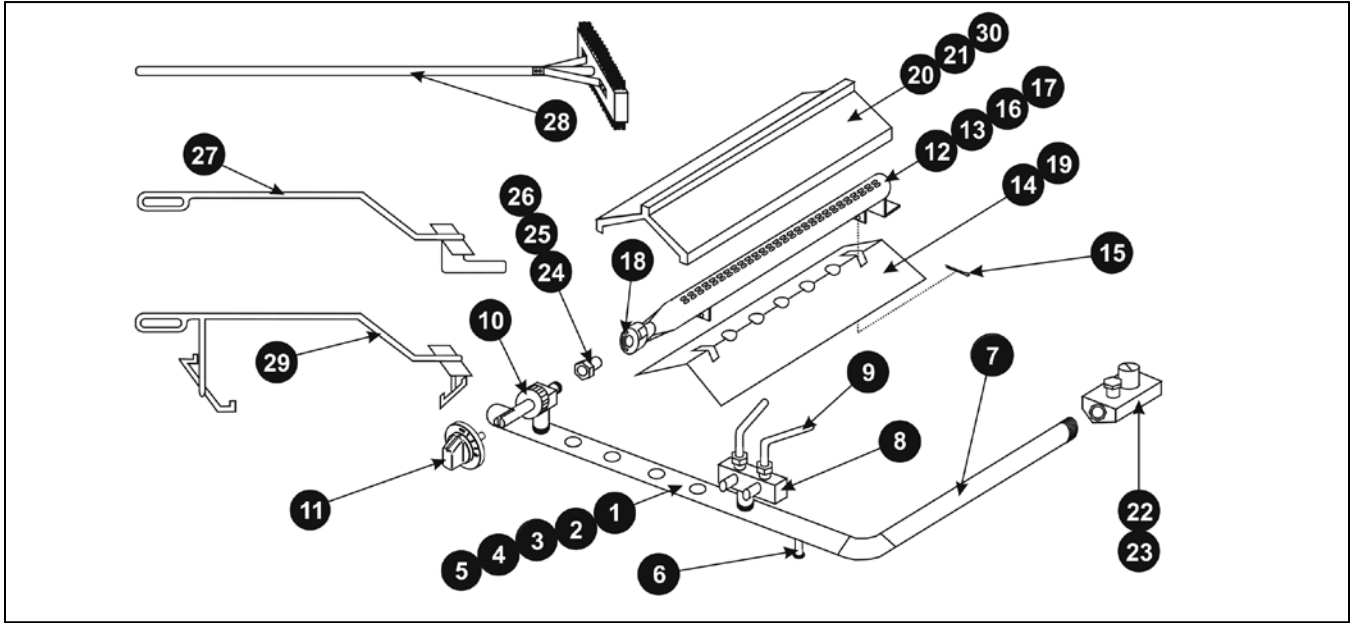

Figure 3: Side View - XX Series

PARTS LISTS AND EXPLODED VIEWS

EXPLODED VIEW – XX-4, 6, 8, 10, 12 Burner / Accessories



| Item | Part No. | Description |
|------|----------|-------------------------------------|
| 1 | R1017X | Manifold Assy (XX-4) |
| 2 | R1018X | Manifold Assy (XX-6) |
| 3 | R1019X | Manifold Assy (XX-8) |
| 4 | R1020X | Manifold Assy (XX-10) |
| 6 | N3068P | Pressure Tap Nozzle Assy |
| 7 | N5217A | Gas Inlet Pipe (XX Series) |
| 8 | R3020X | Valve, Pilot-Dual |
| 9 | R3042X | Pilot Tubing, 7 3/8" (XX Series) |
| 10 | R3032X | Valve, Burner (LML) w.o./Knob |
| 11 | S1416X | Knob, Gas Valve, On/Off (XX Series) |
| 12 | L5019X | Burner Assy Complete, Tube 24" (XX) |
| 13 | L5013X | Burner Only, Tube 24" (XX) |
| 14 | H1044X | Grease Guard Only (Tube Burner) |
| 15 | Q4008X | Cotter Pin, 1/8" x 2" |

| Item | Part No. | Description |
|------|----------|---|
| 16 | L5027V | Burner Assy Complete, C.I. 24" (XX) O/S |
| 17 | L5014V | Burner Only, C.I. 24" w/ Mixer Cap (XX) O/S |
| 18 | R3022X | Air Mixer Cap w/Screw (C.I. Burner only) |
| 19 | H1008X | Grease Guard Only (C.I. Burner) |
| 20 | T1007A | Radiant Cast Iron (23") Optional (Shown) |
| 21 | T1155T | Radiant S/S (23") Standard |
| 22 | M1009X | Pressure Regulator, 3/4", 10" WC |
| 23 | M1008X | Pressure Regulator, 3/4", 5" WC |
| 24 | R3043X | Orifice Hood #47, Nat (XX) |
| 25 | R3044X | Orifice Hood #55, LP (XX) |
| 26 | R3023X | Orifice Hood, Blank |
| 27 | T5041T | Grate Lifter (Cast Iron), 3' x 20" |
| 28 | T5104V | Twin Head Grate Brush |
| 29 | G5221U | Grate Lifter (Roll-A-Grate) |
| 30 | G1290U | Bottom Grate Burner Shield (Glo-Stone Only) |

| Conversion Kit (LP to NAT) | |
|----------------------------|---|
| R3043X | Hood Orifice #47, Nat, (XX-4 uses 4) (XX-6 uses 6) (XX-8 uses 8) (XX-10 uses 10) |
| M1008X | Pressure regulator 3/4", 5" WC (Qty 1) |

| Conversion Kit (NAT to LP) | |
|----------------------------|--|
| R3044X | Hood Orifice #55, LP, (XX-4 uses 4) (XX-6 uses 6) (XX-8 uses 8) (XX-10 uses 10) |
| M1009X | Pressure regulator 3/4", 10" WC (Qty 1) |

Note: When ordering, ALWAYS specify Part #, Model #, Serial #, Voltage/Phase and Gas Type.

PARTS LISTS AND EXPLODED VIEWS

EXPLODED VIEW – XX-4, 6, 8, 10, 12 Exterior / Grates

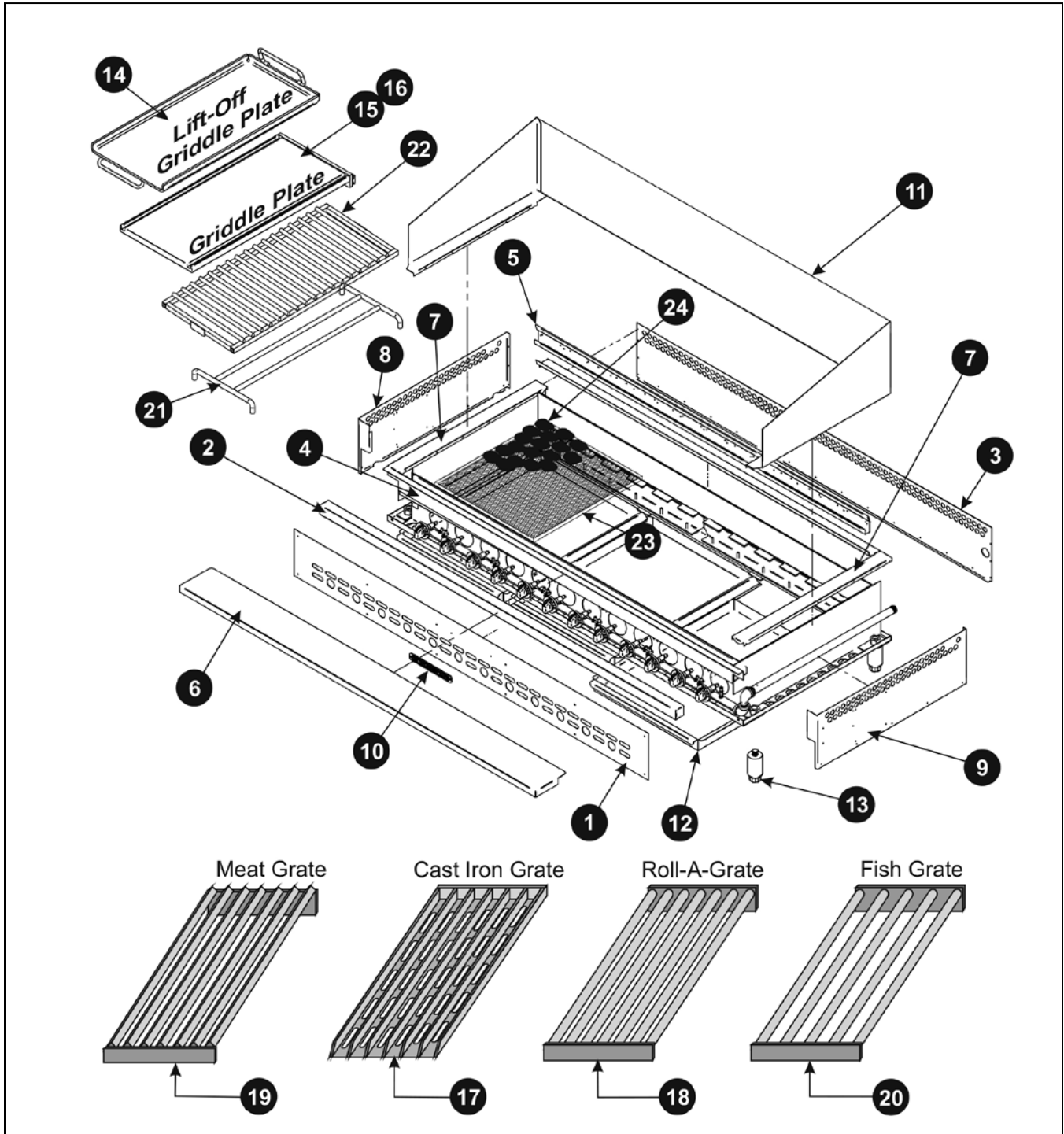

Note: When ordering, ALWAYS specify Part #, Model #, Serial #, Voltage/Phase and Gas Type.



XX & CH CHARBROILER OPERATION MANUAL

PARTS LISTS AND EXPLODED VIEWS

| Item | Part No. | Description |
|------|----------|---------------------------------|
| 1 | G1013X | Control Panel (XX-4) |
| | G1014X | Control Panel (XX-6) |
| | G1015X | Control Panel (XX-8) |
| | G1016X | Control Panel (XX-10) |
| 2 | G1007X | Top Front Trim (XX-4) |
| | G1008X | Top Front Trim (XX-6) |
| | G1009X | Top Front Trim (XX-8) |
| | G1010X | Top Front Trim (XX-10) |
| 3 | G1122K | Outer Back (XX-4) |
| | G1123K | Outer Back (XX-6) |
| | G1124K | Outer Back (XX-8) |
| | G1125K | Outer Back (XX-10) |
| 4 | G1051K | Front Brace (XX-4) |
| | G1052K | Front Brace (XX-6) |
| | G1053K | Front Brace (XX-8) |
| | G1054K | Front Brace (XX-10) |
| 5 | G1021X | 1st/2nd Level Assy (XX-4) |
| | G1022X | 1st/2nd Level Assy (XX-6) |
| | G1023X | 1st/2nd Level Assy (XX-8) |
| | G1024X | 1st/2nd Level Assy (XX-10) |
| 6 | G1070X | Work Deck, S/S (XX-4) Optional |
| | G1078X | Work Deck, S/S (XX-6) Optional |
| | G1079X | Work Deck, S/S (XX-8) Optional |
| | G1080X | Work Deck, S/S (XX-10) Optional |
| 7 | G1011X | Top Side Trim, SS, Left |
| | G1012X | Top Side Trim, SS, Right |
| 8 | G1126X | Outer Side, Left (XX) |
| 9 | G1127K | Outer Side, Right (XX) |
| 10 | U1044X | Name Plate, 8", Bakers Pride |

| Item | Part No. | Description |
|------|----------|---|
| 11 | G1081X | Splash Guard, S/S (XX-4) Optional |
| | G1082X | Splash Guard, S/S (XX-6) Optional |
| | G1083X | Splash Guard, S/S (XX-8) Optional |
| | G1084X | Splash Guard, S/S (XX-10) Optional |
| 12 | T3033T | Grease Pan (XX-4 & 12) 20 3/8", 1 used |
| | T3034T | Grease Pan (XX-6 & XX-10) 30 7/8", 1 used |
| | T3035T | Grease Pan (XX-8) 19 5/8", 2 used |
| | T3036T | Grease Pan (XX-10) 19 1/2", 1 used |
| 13 | S1394Y | Leg, 4" Adjustable, Cylindrical 2" Dia. (Each) |
| | S1394X | Leg, 4" Adjustable, Cylindrical 2" Dia. (Set/4) |
| | G1495A | Leg Adaptor (Not Shown) (Needed for old style tapered, hex top legs only) |
| 14 | T1241U | Lift-Off Griddle 10 1/2" |
| 15 | T1251T | In-Line Griddle 10 1/2" |
| 16 | T1020T | Griddle Plate 16" |
| 17 | T1216A | Grate, Top, Flat Cast Iron (4 1/2") |
| | T1212A | Grate, Top, Flat Cast Iron (6") |
| 18 | T1199U | Roll-A-Grate (4 1/2") |
| | T1198U | Roll-A-Grate (6") |
| 19 | T1217U | Grate, Meat (4 1/2") |
| | T1210U | Grate, Meat (6") |
| 20 | T1230T | Grate, Fish (4 1/2") |
| | T1229T | Grate, Fish (6") |
| | T1166T | Grate, Fish (10 1/2") |
| 21 | T1183T | Grate, Fajita, Bottom |
| 22 | T1185S | Grate, Fajita, Top |
| 23 | T1243U | Long Bottom Grate 31 9/16 (Glo-Stone Option Only) |
| | T1242U | Short Bottom Grate 21 1/16 (Glo-Stone Option Only) |
| 24 | T1250A | Briquettes, Ceramic 9.5 lb Bag (Glo-Stone Option Only) |
| | NOTE: | XX-4: (1) T1242U, (2) T1250A XX-6: (1) T1243U, (3) T1250A XX-8: (2) T1242U, (4) T1250A XX-10: (1) T1242U, (1) T1243U, (5) T1250A |

PARTS LISTS AND EXPLODED VIEWS

EXPLODED VIEW – CH-6, 8, 10, 12, 14

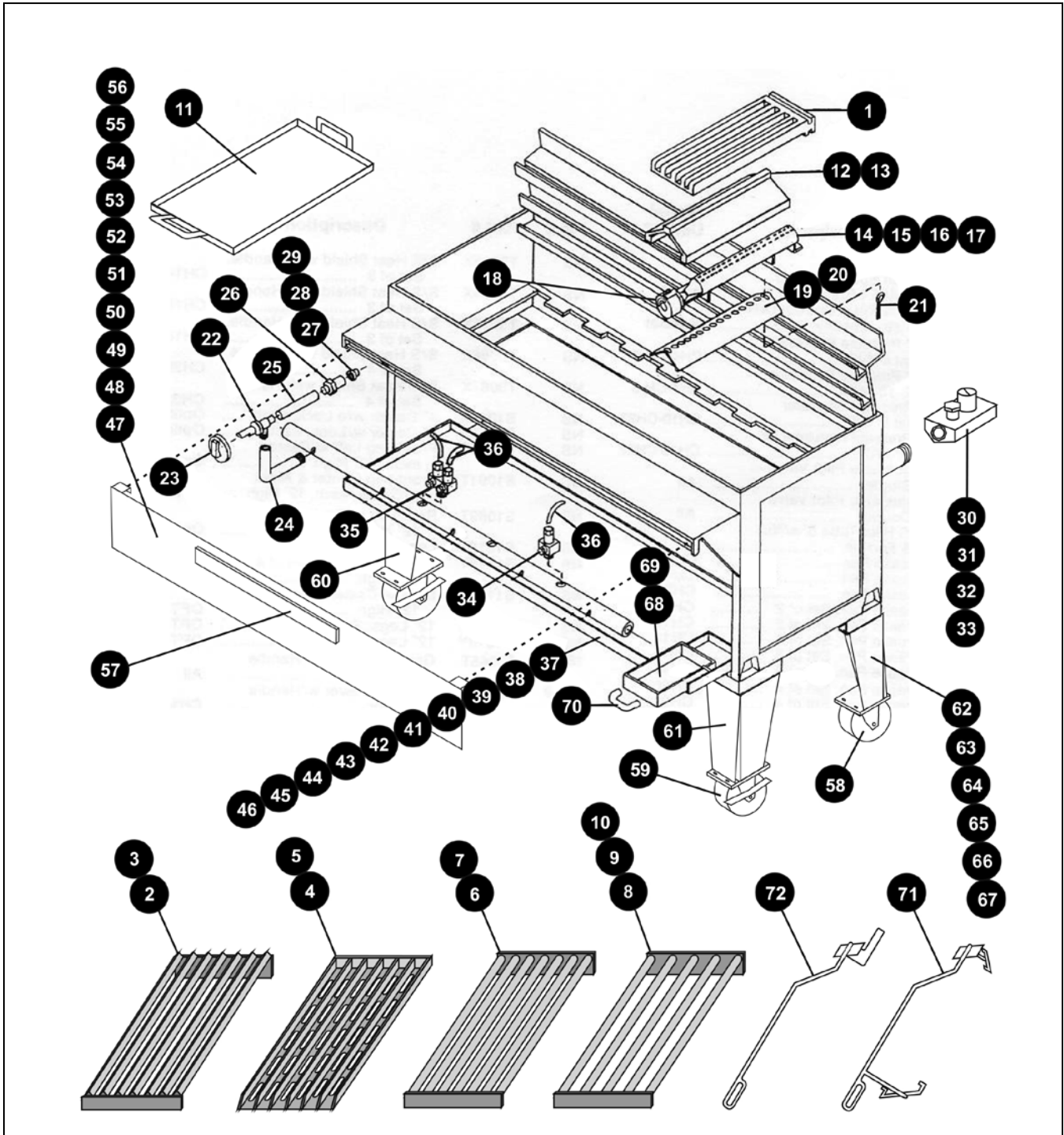

Note: When ordering, ALWAYS specify Part #, Model #, Serial #, Voltage/Phase and Gas Type.



XX & CH CHARBROILER OPERATION MANUAL

PARTS LISTS AND EXPLODED VIEWS

| Item | Part No. | Description |
|------|----------|--|
| 1 | T1006A | Top Grate 5 1/4' Wide 2 |
| 2 | T1217U | Grate, Meat (4 1/2") |
| 3 | T1210U | Grate, Meat (6") |
| 4 | T1216A | Grate, Top, Flat Cast Iron (4 1/2") |
| 5 | T1212A | Grate, Top, Flat Cast Iron (6") 6 |
| 6 | T1199U | Roll-A-Grate (4 1/2") |
| 7 | T1198U | Roll-A-Grate (6") |
| 8 | T1230T | Grate, Fish (4 1/2") |
| 9 | T1229T | Grate, Fish (6") |
| 10 | T1166T | Grate, Fish (10 1/2") N/S |
| N/S | T1228T | Grate, Tango (6") N/S |
| N/S | T1227T | Grate, Tango (9") |
| 11 | T1020T | Griddle Plate (Optional) |
| 12 | T1007A | Radiant Deflector (Cast Iron) |
| 13 | T1155T | Radiant Deflector (Stainless Steel) |
| 14 | L5019X | Tube Burner Assy w/Grease Guard |
| 15 | L5013X | Tube Burner w/Air Mixer Cap |
| 16 | L5027V | Cast Iron Burner w/Grease Guard O/S |
| 17 | L5014V | Cast Iron Burner w/Air Mixer Cap O/S |
| 18 | R3022X | Air Mixer Cap w/Screw (for O/S CI Burner) |
| 19 | H1044K | Burner Grease Guard |
| 20 | H1008K | Burner Grease Guard (for O/S CI Burner) |
| 21 | Q4008A | Cotter Pin |
| 22 | R3032X | Gas Valve (without knob) |
| 23 | S1094X | Gas Valve Knob |
| 24 | N1006X | Curved Valve Extension |
| 25 | N1005X | 3 5/8" Straight Valve Extension |
| 26 | R3025X | Orifice Holder (Only) |
| 27 | R3028X | Orifice Spud #49 Drill (.073") Nat. |
| 28 | R3031X | Orifice Spud #56 Drill (.0465") LP |
| 29 | R3026X | Orifice Spud - Special Drill Size (Specify) |
| 30 | M1008X | Pressure Regulator 3/4" Nat 5"WC (CH 6, 8) |
| 31 | M1009X | Pressure Regulator 3/4" LP 10"WC (CH 6, 8) |
| 32 | M1066X | Pressure Regulator 1" Nat 5"WC (CH 10, 12, 14) |
| 33 | M1067X | Pressure Regulator 1" LP 10"WC (CH 10, 12, 14) |
| 34 | R3021X | Adjustable Pilot Valve (Single) |
| 35 | R3020X | Adjustable Pilot Valve (Double) |
| 36 | R3034X | S/S Pilot Tube 6" w/nut & ferrule |
| 37 | T3015T | Grease Pan (CH-4) |
| 38 | T3016T | Grease Pan (CH-6) |
| 39 | T3018T | Grease Pan (CH-8) |

| Item | Part No. | Description |
|------|----------|--|
| 40 | T3120X | Grease Pan, set/2 (CH-10) |
| 41 | T3121X | Grease Pan, set/2 (CH-12) |
| 42 | T3122X | Grease Pan, set/3 (CH-14) |
| 43 | T3123X | Grease Pan, set/3 (CH-16) |
| 44 | T3124X | Grease Pan, set/3 (CH-18) |
| 45 | T3125X | Grease Pan, set/4 (CH-20) |
| 46 | T3126X | Grease Pan, set/4 (CH-22) |
| 47 | T3078V | S/S Heat Shield w/Handle (CH-4) |
| 48 | T3079V | S/S Heat Shield w/Handle (CH-6) |
| 49 | T3080V | S/S Heat Shield w/Handle (CH-8) |
| 50 | T3081X | S/S Heat Shield w/Handle set/2 (CH-10) |
| 51 | T3082X | S/S Heat Shield w/Handle set/2 (CH-12) |
| 52 | T3083X | S/S Heat Shield w/Handle set/3 (CH-14) |
| 53 | T3084X | S/S Heat Shield w/Handle set/3 (CH-16) |
| 54 | T3085X | S/S Heat Shield w/Handle set/3 (CH-18) |
| 55 | T3086X | S/S Heat Shield w/Handle set/4 (CH-20) |
| 56 | T3087X | S/S Heat Shield w/Handle set/4 (CH-22) |
| 57 | S1134X | Heat Shield Handle w/Hardware |
| 58 | S1022X | 4" Caster w/o Lock (each) |
| 59 | S1023X | 4" Caster w/Lock (each) |
| 60 | S1090T | Front Leg Left w/caster 12" (each) |
| 61 | S1091T | Front Leg Cen. & Right w/caster 12" (each) |
| 62 | S1089T | Rear Leg w/caster 12" (each) |
| 63 | S1018T | Leg 12" (each) |
| 64 | S1115Y | Legs w/Casters set/4 (12") |
| 65 | S1116Y | Legs w/Casters set/6 (12") |
| 66 | S1017Y | 12" Legs set/6 |
| 67 | S1018Y | 12" Legs set/4 |
| 68 | T3045T | Grease Drawer w/Handle Left (All) |
| 69 | T3046T | Grease Drawer w/Handle Right (CH14-22) |
| 70 | S1016X | Grease Drawer Handle w/Screws |
| 71 | G5221U | Grate Lifter (Roll-A-Grate) |
| 72 | T5041T | Grate Lifter (Cast Iron) 3' x 20" |
| N/S | T1190A | Richlite CH-6 (Optional) |
| N/S | T1189A | Richlite CH-8 (Optional) |
| N/S | T1174A | Richlite CH-10 (Optional) |
| N/S | T1122A | Richlite CH-12 (Optional) |
| N/S | T1123A | Richlite CH-14 (Optional) |
| N/S | H1530S | Splash Sides (Set/2) |
| N/S | T1251T | Griddle Plate 10 1/2" (In Line) |
| N/S | T1252T | Griddle Plate 18" (In Line) |

| Conversion Kit (LP to NAT) | |
|----------------------------|---|
| R3028X | Orifice Spud #49 Drill (.073") Nat. (CH-6 uses 6) (CH-8 uses 8) (CH-10 uses 10) (CH-12 uses 12) (CH-14 uses 14) |
| M1008X | Pressure regulator 3/4", 5" WC (CH-6, 8) |
| M1066X | Pressure regulator 1", 5" WC (CH-10, 12, 14) |

| Conversion Kit (NAT to LP) | |
|----------------------------|--|
| R3031X | Orifice Spud #56 Drill (.0465") LP (CH-6 uses 6) (CH-8 uses 8) (CH-10 uses 10) (CH-12 uses 12) (CH-14 uses 14) |
| M1009X | Pressure regulator 3/4", 10" WC (CH-6, 8) |
| M1067X | Pressure regulator 1", 10" WC (CH-10, 12, 14) |

Note: When ordering, ALWAYS specify Part #, Model #, Serial #, Voltage/Phase and Gas Type.



HEAVY DUTY GAS CHARBROILER OPERATION MANUAL

BAKERS PRIDE LIMITED WARRANTY

| | |
|--------------------------|--|
| WHAT IS COVERED | <p>This warranty covers defects in material and workmanship under normal use, and applies only to the original purchaser providing that:</p> <ul style="list-style-type: none">• The equipment has not been accidentally or intentionally damaged, altered or misused;• The equipment is properly installed, adjusted, operated and maintained in accordance with National and local codes and in accordance with the installation instruction provided with the product;• The serial number rating plate affixed to the equipment has not been defaced or removed. |
| WHO IS COVERED | <p>This warranty is extended to the original purchaser and applies only to equipment purchased for use in the U.S.A.</p> |
| COVERAGE PERIOD | <p>Cyclone Convection Ovens: BCO Models: One (1) Year limited parts and labor; (1) Year limited door warranty. GDCO Models: Two (2) Year limited parts and labor; (2) Year limited door warranty. CO11 Models: Two (2) Year limited parts and labor; (5) Year limited door warranty. All Other Products: One (1) Year limited parts and labor. Warranty period begins the date of dealer invoice to customer or ninety (90) days after shipment date from Bakers Pride - whichever comes first.</p> |
| WARRANTY | <p>This warranty covers on-site labor, parts and reasonable travel time and travel expenses of the authorized service</p> |
| COVERAGE | <p>representative up to (100) miles, round trip, and (2) hours travel time. The purchaser, however, shall be responsible for all expenses related to travel, including time, mileage and shipping expenses on smaller counter models that may be carried into a Factory Authorized Service Center, including the following models: PX-14, PX-16, P18, P22S, P24S, PD-4, PDC, WS Series and BK-18.</p> |
| EXCEPTIONS | <p>All removable parts in Bakers Pride® Charbroilers, including but not limited to: Burners, Grates, Radiants, Stones and Valves, are covered for a period of SIX MONTHS. All Ceramic Baking Decks are covered for a period of THREE MONTHS. The installation of these replacement decks is the responsibility of the purchaser. The extended Cyclone door warranty years 3 through 5 is a parts only warranty and does not include labor, travel, mileage or any other charges.</p> |
| EXCLUSIONS | <ul style="list-style-type: none">• Negligence or acts of God,• Failures caused by erratic voltages or gas supplies,• Thermostat calibrations after (30) days from equipment installation date,• Unauthorized repair by anyone other than a Bakers Pride Factory Authorized Service Center,• Air and Gas adjustments,• Damage in shipment,• Light bulbs,• Alteration, misuse or improper installation,• Glass doors and door adjustments,• Thermostats and safety valves with broken capillary tubes,• Fuses,• Char-broiler work decks and cutting boards,• Tightening of conveyor chains,• Adjustments to burner flames and cleaning of pilot burners,• Tightening of screws or fasteners.• Accessories — spatulas, forks, steak turners, grate lifters, oven brushes, scrapers, peels. etc.,• Freight — other than normal UPS charges,• Ordinary wear and tear. |
| INSTALLATION | <p>Leveling and installation of decks as well as proper installation and check out of all new equipment —per appropriate installation and use materials — is the responsibility of the dealer or installer, not the manufacturer.</p> |
| REPLACEMENT PARTS | <p>Bakers Pride genuine Factory OEM parts receive a (90) day materials warranty effective from the date of installation by a Bakers Pride Factory Authorized Service Center.</p> |

This Warranty is in lieu of all other warranties, expressed or implied, and all other obligations or liabilities on the manufacturer's part. Bakers Pride shall in no event be liable for any special, indirect or consequential damages, or in any event for damages in excess of the purchase price of the unit. The repair or replacement of proven defective parts shall constitute a fulfillment of all obligations under the terms of this warranty.

Standex

Food Service Equipment Group

The Standex Food Service Equipment Group (FSEG) is a manufacturer of innovative commercial food service equipment offering a wealth of refrigeration and cooking expertise. Products include walk-in coolers and freezers; hot and cold display cabinets, cases, and storage systems; commercial ovens, rotisseries, and cooking equipment; and rotary vane pumps.

Ask your sales representative about how the power of all Standex brands can work for you.
www.standex.com/segments/food-service



Be sure to keep up with new product announcements and events on social media!

