



OPERATION MANUAL
SUPERDECK SERIES ELECTRIC DECK OVENS
SERIES: EP, EB, & ER



BUILT BY CRAFTSMEN. TESTED BY TIME®.



FLOOR MODEL ELECTRIC DECK OVEN OPERATION MANUAL

BP SERIES RANGES

Models:

EP, EB, ER

Bakers Pride Oven Company, LLC is a wholly owned subsidiary of Standex International Corporation.

Congratulations on your purchase of a Bakers Pride® electric deck oven.

Please retain this manual for future references.

This equipment is design engineered for commercial use only.

⚠ WARNING

FOR YOUR SAFETY: Do not store or use gasoline or other flammable vapors or liquids in the vicinity of this or any other appliance.

⚠ WARNING

California Residents Only
WARNING: This product can expose you to chemicals including chromium which is known to the State of California to cause cancer and birth defects or other reproductive harm. For more information go to www.P65Warnings.ca.gov.

⚠ CAUTION

Improper installation, adjustment, alteration, service or maintenance can cause property damage, injury or death. Read the installation, operating and maintenance instructions thoroughly before installing or servicing this equipment.

NOTICE

Instructions to be followed in the event the user smells gas must be posted in a prominent location in the kitchen area. This information shall be obtained from the local gas supplier.

⚠ WARNING

Initial heating of oven may generate smoke or fumes and must be done in a well-ventilated area. Overexposure to smoke may cause nausea or dizziness.



BAKERS PRIDE OVEN COMPANY, LLC.

1307 N. Watters Rd., Suite 180
Allen, TX 75013

Phone: 800.527.2100 | Fax: 914.576.0605 | www.bakerspride.com

P/N U4190A 9/18



TABLE OF CONTENTS

INSTALLATION INSTRUCTIONS	1	OPERATING INSTRUCTIONS	7
RECEIVING	1	GENERAL BAKING	7
LOCATION AND MINIMUM CLEARANCES	1	GENERAL BAKING TIPS	7
INSTALLATION	1	SPECIAL FEATURES	8
STACKING	3	CLEANING	8
STEAM OPTION	3	SERVICE AND TROUBLESHOOTING	9
INSTALLATION OF DECKS	4	SERVICE AND TROUBLESHOOTING CHART	10
ELECTRICAL CONNECTION	5	RATING PLATE	10
SYSTEM CHECK	6	PARTS LIST W/EXPLODED VIEW	11
INITIAL START-UP	6	WIRING DIAGRAMS	13
		WARRANTY	19

Models Covered

Model	Elements Per Deck	Total Kw Per deck	Phase	Model	Elements Per Deck	Total Kw Per deck	Phase
EP1(2,3)-8-3836	8	8	1 or 3	EB1(2,3)-8-5736	12	12	1 or 3
EP1(2,3)-8-5736	12	12	1 or 3	ER1(2,3)-12-3836	8	8	1 or 3
EB1(2,3)-8-3836	8	8	1 or 3	ER1(2,3)-12-5736	12	12	1 or 3

INSTALLATION INSTRUCTIONS

Receiving

Read the notice on the outside carton regarding damage in transit. "CONCEALED DAMAGE", damage discovered after opening the crate(s), must be reported immediately to the carrier. The carrier will perform an inspection of the damage and furnish forms for the consignee's claim against the carrier. Retain all packing material- including outer carton until the inspection has been completed.

Location And Minimum Clearances

Adequate air space must be provided for proper venting of the controls and provisions must be made for venting of the cooking vapors. The Oven must be installed in a well-ventilated area and following minimum clearances must be maintained at all times:

Ovens can be installed with "Zero" clearances (back and sides) from combustible and non-combustible materials.

The Ovens may be installed on combustible Flooring if mounted on the Legs provided. Keep the area around your oven free and clear of all combustible materials.

Installation

Place the oven and parts as close to the area of final installation before un-crating. Your oven is packed sitting on its back. Leave it on its back while unpacking. The pallet may be left under oven for convenience in further handling. Unpack carefully to avoid damage to the oven. If concealed damage is discovered, follow the instructions detailed in Receiving section above.

- a) Legs are shipped in a separate carton complete with mounting bolts and washers. Firmly bolt two legs (in case of casters, the two with the brakes must be used here) to the upper two corners (front) of the oven as it rests on the pallet. Note: (See Fig. 1).
- b) Using sufficient help, tilt the oven forward and lower it down so that the two front legs come to rest on the floor. (See Fig.2)

INSTALLATION INSTRUCTIONS

⚠ WARNING

In case of casters, the brakes must be firmly applied and in a locked position before proceeding with the next step, in order to prevent the oven from rolling away while lifting the back. It is advisable to have a person in front of each caster leg, bracing his foot firmly against the casters.

- c) Using proper lifting equipment, raise the back of the oven to a height slightly more than the height of the legs, remove the pallet and the rest of the packing material and place a sturdy support under the back side. (See Fig. 3)
- d) Mount the two back legs and firmly tighten the bolts, then lift the back of the oven somewhat and remove the support.
- e) Provide a suitable restraining chain or cable to securely tether the appliance to the building structure. The restraining chain or cable should be of such length that it will stop movement of the appliance **BEFORE** there is any strain on the power supply cable.
- f) Move the oven to its final location (in case of casters, release the brakes, then reapply once in position), maintaining the minimum distances specified in Minimum Clearances section above.
- g) Remove all loose parts and packages from the oven interior.
- h) Insert the short piece of tapered pipe supplied (see fig.4) into the hole at the top, located near the left rear corner of the oven (see fig.5A). Turn it to the desired direction, mark the location of the holes and drill three 1/8" diameter holes, then secure it with the screws supplied for that purpose. This pipe is to prevent accidental closure of the vent opening by items stored on top of the oven.

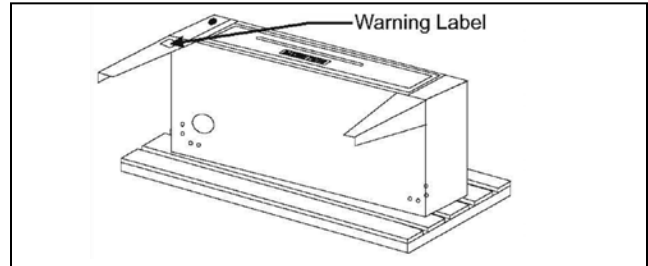

Figure 1

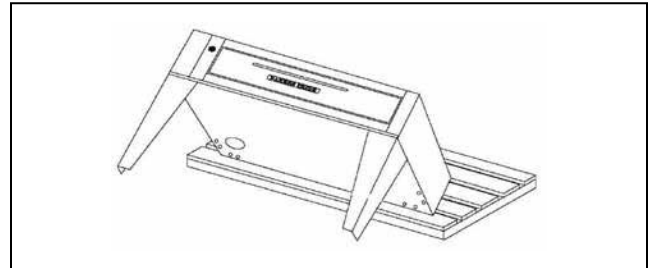

Figure 2

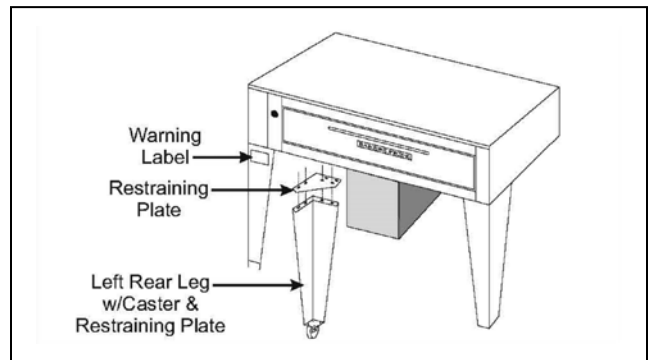

Figure 3

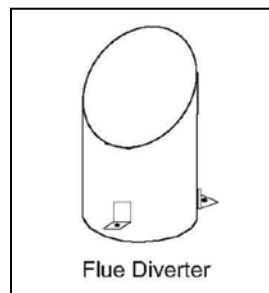

Figure 4

INSTALLATION INSTRUCTIONS

Stacking

These ovens can be stacked up to three high. Each unit is built exactly the same, so it does not matter in what order they are stacked. However, in case of a mix of 8" and 12" deck heights, it is advisable to place the higher deck(s) on the top, e.g.: mount the legs to one of the lower decks.

Once the unit with the legs is in place (in case of casters make sure the brakes are on), with the proper lifting equipment gently place the next oven on top of the first one and line up the back and sides with each other. (If the ovens came with Steam Option, read Steam Option section below before proceeding). Once the two ovens are properly stacked, install the stacking brackets as per instructions supplied with the kit. In case of a third unit, gently place the oven on top of the second one, line up the back and sides, then connect to the stacking brackets.

Steam Option

If this option has been ordered and supplied, remove the control panel(s) and left access cover(s) to gain access to the steam plumbing as follows:

- a) Remove all screws and vent knob from the control panel. Loosen the set screw on the thermostat knob and remove it. Pull the control panel out at the bottom, then down and out from the vent rod. Slip the right flange hole of the control panel back onto the vent rod, then replace the vent knob to keep the control panel in an open and secure position. (See Fig. 5i)
- b) Remove all screws from the left access panel, then pull it forward and out of the oven.
- c) After the internal pipe connections have been completed as per instructions below, follow the instructions supplied by the manufacturer of the steam generator and the manufacturer of the steam trap for final hook up to the steam supply.

Stacked Ovens

- a) In all but the top oven, punch four 1 1/2" diameter holes in each of the top covers, utilizing the 1/8" locating holes. (See Fig. 5b)
- b) Loosen the upper pipe union(s) and remove the upperpart(s) from all but the top oven. (See Fig. 5c).

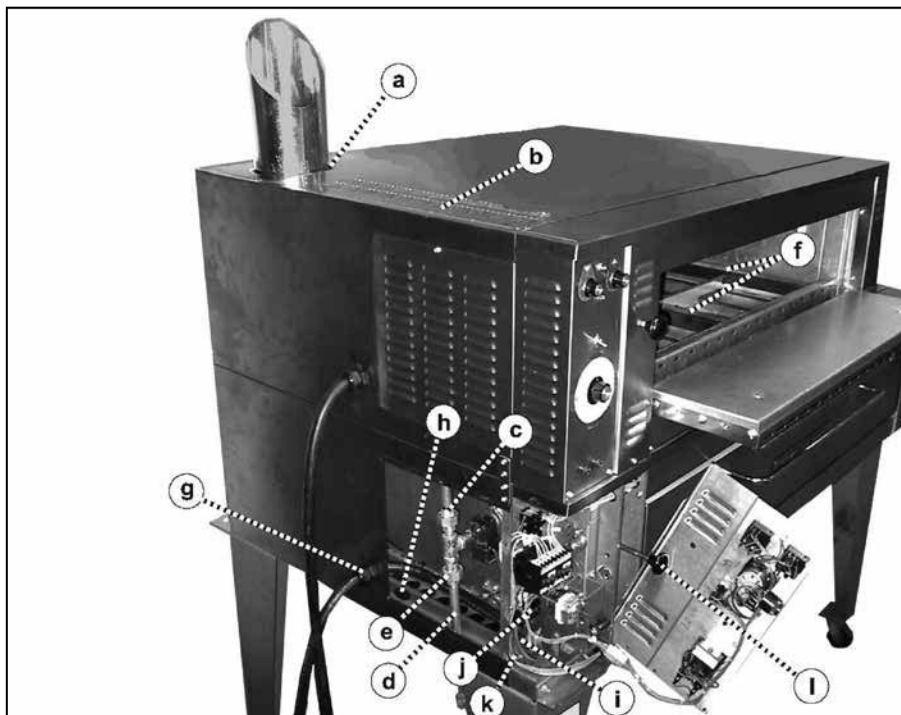

Figure 5

INSTALLATION INSTRUCTIONS

- c) Raise the left side of the upper unit and place a piece of wood or similar material to keep a 1" to 1 1/2" space between the two ovens.
- d) Insert the connecting pipe, small end up, (see Fig. 5d) through the access opening of the lower unit and screw it into the lower pipe union of the upper oven, leaving a space between the lower union sections identical to the space between the two ovens.
- e) Lift the upper unit, remove the spacer and carefully lower it until the two union parts in the lower oven meet. Adjust the height of the connecting pipe, if necessary, to have a perfect match at the lower union, then tighten the lower union.

⚠ WARNING

It is very important to have a good match at the lower union before tightening it. If the connecting pipe is too long or too short, this will put undue stress on the pipe joints and could cause failure of these components and property damage or injuries as well.

- f) At the end, insert the connecting pipe, small end up, through the appropriate opening at the base of the bottom unit and screw it into the lower pipe union.

Single Oven

Insert the connecting pipe, small end up, through the appropriate opening of the base and screw it into the lower pipe union. (See fig. 5e)

Installation Of Decks

Steel Decks

Steel Decks for Bake and Roast Application are factory installed and no further installation is required.

Ceramic Decks

Ceramic Decks for Pizza Application are shipped in a separate carton. Depending on the model, two (see Fig. 6a) or three slabs (see Fig 7a) are provided with each oven. This material is heavy and fragile and should be handled carefully.

- a) Depending on the model, three or four deck supports (metal channels) have to be inserted in the oven, front to back, flanges down and flat side up. (See Fig.5f).
- b) Slide one slab into the bake chamber along the deck supports on the left side, lower the front end carefully to avoid chipping of the deck corners, then push tightly against the left oven wall.
- c) Repeat the above for the second (and third) slab, pushing it as tightly as possible against the previous one to prevent any gaps.
- d) With a long hook or similar tool, reach in and pull all of the slabs as far to the front as possible. Insert one (or two) of the wedges in the back and one at the right side of the oven (see Figs. 6b & 7b) and tap them down lightly.

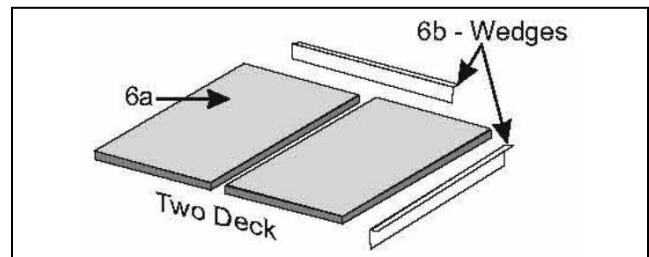

Figure 6

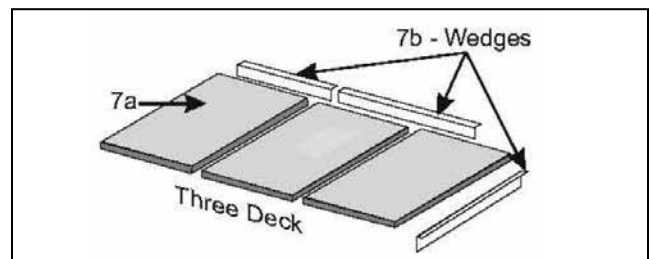

Figure 7

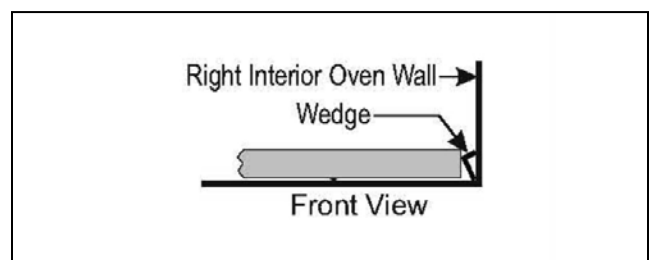

Figure 8



INSTALLATION INSTRUCTIONS

Electrical Connection

General Instructions

- a) Only a licensed electrician should make the electrical connections.
- b) Make sure electrical supply corresponds with that specified on the rating plate.
- c) Only use copper conductors rated at 90°C suitability sized for the electric current drawn.
- d) All pole disconnect(s) must be provided by the installer.
- e) When installed, unit must be electrically grounded in accordance with the local codes and/or the latest edition of the National Electrical Code ANSI/NFPA No. 70 in USA or Canadian Electrical Code, CSA Standard C22.1, Part 1 in Canada.
- f) FOR CE UNITS: The appliance must be connected by an earthing cable to all other units in the complete installation and thence to an independent earth connection in compliance with EN 60335-1 and/or local codes. If flexible line cordage is used to connect the equipment, it should be a minimum of H07RN-F type conforming to EN60335-1 and/or local codes.

E(PBR) – 3836 – 8(12) Power and Current per Deck					Power Supply Volts (Phase)	E(PBR) – 5736 – 8(12) Power and Current per Deck				
KW	L1 (amp)	L3 (amp)	L2 (amp)	N (amp)		KW	L1 (amp)	L3 (amp)	L2 (amp)	N (amp)
8.0	38.6		38.6		208(1)	12.0	57.8		57.8	
8.0	21.0	25.0	21.0		208 (3)	12.0	33.5	33.3	33.5	
7.3 – 8.7	33.3-36.3		33.3-36.3		220-240 (1)	11.0-13.0	50.0-54.6		50.0-54.6	
7.3 – 8.7	18.0-19.7	21.5-23.5	18.0-19.7		220-240 (3)	11.0-13.0	29.0-31.6	28.9-31.5	29.0-31.6	
7.3 – 8.7	16.7-18.2		16.7-18.2		440-480 (1)	11.0-13.0	25.0-27.3		25.0-27.3	
7.3 – 8.7	9.0-10.0	10.8-11.8	9.0-10.0		440-480 (3)	11.0-13.0	14.5-15.8	14.4-15.7	14.5-15.8	
8.0	35.0			35.0	400-Y (1)	12.0	52.3			52.3
8.0	8.38	13.0	13.0	4.2	400-Y (3)	12.0	17.5	17.4	17.4	0.1

NOTE: EACH OVEN REQUIRES A SEPARATE CONNECTION !

⚠ CAUTION

Overexposure to smoke or fumes may cause nausea and dizziness. Be sure the oven is placed in a well ventilated area.

Field Connections

- a) Remove all screws and vent knob from the control panel(s). Pull control panel out at the bottom, then down and out from the vent rod. Slip the right flange hole of the control panel back onto the vent rod, then replace the vent knob to keep the control panel in an open and secure position.
- b) Remove all screws from the left access panel(s), then pull forward and out of the oven.
- c) Feed power cable (supplied by the customer) through the access hole at the left side (see Fig 5g) or at the bottom (see fig. 5h) of the oven and pull the cable to the front of the oven where it may be attached to the opening in the oven frame. See fig. 5i).
- d) Following the appropriate wiring diagram conforming to the rating plate, connect the power supply leads to the field wiring terminal block (see fig. 5j). The ground wire should be connected to the grounding lug (see fig. 5k) attached to the oven frame.
- e) For single phase 2-wire or three phase 3-wire supplies, the controlling branch circuit is designed to operate at 208-240 volts AC and is pre-wired at the factory between L1 and L2 of the field wiring terminal block.

Stacked ovens only!

In all but the top oven, punch four 1 1/2" diameter holes in each of the top covers, utilizing the 1/8 locating holes. (See Fig. 5b)



INSTALLATION INSTRUCTIONS

- f) For three phase 4-wire 230/400 Volts AC 50hz supplies, the controlling branch circuit is designed to operate at 230 volts AC and is pre-wired at the factory between L1 and N of the field wiring terminal block.
- g) Make sure all connections are tight, then replace the access cover(s) and control panel(s).

System Check

- a) Flip up oven light switch. Oven lights will go on, and off as the switch is pushed down again.
- b) Set the Top (right) and Bottom (left) Heat switches to "0" (off).
- c) Turn the Thermostat knob to 300°F (150°C). Nothing should happen.
- d) Turn the Top (right) heat switch counter-clockwise to "5". The top amber indicator lamp will illuminate; the right contactor will be activated and the top heating elements will be energized. After some time, these items will start to cycle on and off.
- e) Turn the Top (right) heat switch clock wise to "10" (high). The top amber indicator lamp will illuminate; the right contactor will be activated and the top heating elements will be energized and all should stay that way until the heat switch is turned back to "0" again or the preset temperature has been reached.
- f) Repeat d) and e) above with the Bottom (left) Heat switch. The results should be the same as above, except this time it will be the bottom indicator lamp, the left contactor and the bottom heating elements.

Ovens with Timer Option

Turn the timer knob clockwise past the "0" and set a time of 2 minutes. At the end of 2 minutes, the timer knob will be at "0", you will hear the buzzer and see the green indicator lamp on, and all three will stay that way until you turn the timer knob counter-clockwise to "0" to switch them off, or turn the knob clockwise for more time and repeat the above with the same or a different setting.

Ovens with Steam Option

Never activate the steam timer when the oven is cold, since the steam will immediately condense and turn to water.

- a) The steam timer can be adjusted from 1 to 60 seconds and has been factory set for 3-5 seconds. To change this time, insert a small screw driver through the 1/4" diameter hole below the steam switches and turn the timer shaft clockwise to increase or counter-clockwise to decrease this time delay setting.
- b) Press both steam switches simultaneously. The red indicator lamp will illuminate; the solenoid coil will be activated and the solenoid valve will open and allow steam to enter the baking chamber for the duration of the selected time. After that period, the power to the red indicator lamp and solenoid coil will be cut off and the solenoid valve will shut down the flow of steam to the oven.

⚠ WARNING

Never open the door while the red indicator lamp is on and steam is being injected into the oven, since exposure to live steam can cause serious injuries.

Initial Start-Up

After installation, your oven will need a few hours to evaporate the moisture in the deck and in the insulation and to burn off the thin coat of oil on the sheet metal parts. The following steps must be completed before your new oven is ready for use:

- a) Place the oven in a well-ventilated area in order to deal with the ensuing smoke and smell.
- b) Open the oven door and make sure the oven cavity is empty and that the decks are properly installed (see Installation of Decks section).
- c) Close the oven door and set the temperature knob to 300°F (150°C) for about an hour or so.



INSTALLATION INSTRUCTIONS

- d) After that, increase the temperature to 500°F (260°C) for at least another hour or until all the smoke and fumes have disappeared. This procedure will remove most of the moisture and help insure good bake results.

⚠ CAUTION

Overexposure to smoke or fumes may cause nausea and dizziness. Be sure the oven is placed in a well ventilated area.

OPERATING INSTRUCTIONS

General Baking

NOTICE

Only Pizza and Bread products can have direct contact with the Ceramic Deck. All other food products must be placed in a metal pan or porcelain dish to avoid direct contact with the ceramic deck.

Pizza can be baked on the deck, on a screen or in a pan. When you determine the combination of method, ingredients and temperature that results in the right bake for your crust, sauce and cheese combination and your customer's taste, mark and keep it.

Deck baking refers to baking Pizza directly on the deck. Generally, it is a thin product that requires temperature of at least 550°F (290°C).

Screen baking refers to baking Pizza on a screen. The screen lifts the Pizza off the deck. The screen may be removed near the end of the bake time to give the bottom of the Pizza a crispier crust and a darker color. Bake temperatures range from 500°F (260°C) to 550°F (290°C).

Pan baking refers to baking Pizza in pans. Crusts can be thick or thin and toppings range from light to heavy. Bake temperatures for pan baking range from 450°F (235°C) to 500°F (260°C).

General Baking Tips

- At day's end, turn the thermostat to the "0" (off) position to conserve energy, leaving the Top and Bottom Heat controls set for next day's operation.
- In the morning, preheat for one hour at 50°F (30°C) lower than your baking temperature with the vent closed (pushed all the way in) for a faster recovery.
- 15 to 20 minutes before loading the oven, raise the thermostat setting to your baking temperature and make sure the Top and Bottom Heat switches are set correctly for the product you intend to bake.
- Check the bottom color of the Pie and reduce the Top Heat once you notice the bottoms to get very light. This will make the bottom elements come on more often helping to maintain the desired color.
- When the oven has not been used for a while, there is a tendency for the bake deck to get very hot. Consequently, when it is slow and the oven idling, set the thermostat at least 50°F (30°C) lower than your normal baking temperature. Then, when you put in a pizza, increase the normal setting, providing the quick extra top heat required to balance the bottom heat. At the end of the bake, the thermostat should then be turned down to lower setting before the deck gets too hot again.
- Frequently scrape and brush off decks top remove burnt residue which can cause an "off" flavor and increase bake time.



OPERATING INSTRUCTIONS

- g) Heavily topped Pizza or Pan Pizza require lower bake temperatures and longer bake times as compared to a regular thin Pizza with light toppings.
- h) Bubbles in fresh dough indicate an under-proofed or cold product. Allow the dough balls to proof in a warm area and to double in size before baking.
- i) Any type of Pan or Screen may be used in this oven. When choosing pans, be sure to pick a pan which is closest in height of your product.

NOTICE

Dark colored pans and screens transfer heat better than light colored aluminum pans or screens. The latter ones must be seasoned before use. To do this, apply a heavy coating of cooking oil inside and out and bake in oven at 500°F (260°C) for about an hour or until all smoke has gone.

Special Features

Heating Elements:

For a more even heat distribution, these ovens have evenly spaced u-shaped heating elements throughout that are either “ALL ON” or “ALL OFF”, depending on the temperature setting and the Top and Bottom Heat selections made.

Infinite Switches:

To better control the ratio of Top and Bottom Heat, these ovens have two heat selector switches, one controlling the Top Heat the other controlling the Bottom Heat. Each allows a setting from #1 (low= 20% on/80% off) through #9 (80% on/20% off) to #10 (high = 100% on). In order to maximize the potential of the oven and to get maximum power, both heat selector switches should be set to #10 (high). This will be the best setting most of the time for most of the products. However, if, after some experimenting, one of the two proves to be too hot, only that one should be reduced while the other one stays on high. There is no need to reduce both at the same time. If less heat is required, lower the thermostat setting.

Optional Timer:

Upon request, an electric timer is provided to give an audible, continuous signal at the end of a preset time up to 60 minutes (72 minutes with 50Hz supply) on Bake Ovens and up to 5 hours (6 hours with 50Hz supply) on Roast Ovens.

NOTE: The Timer does not control the heating elements.

Oven Lights:

The lights that illuminate your oven cavity should not be left on when the door is closed. Leaving the lights on in a hot oven for an extended time may cause them to fail.

Cleaning

Oven Exterior:

Clean Only When The Oven Is Cold.

- a) Deposits of baked-on splatter and grease, or discoloration may be removed with the stainless steel cleaner sample supplied or by using any commercial cleaner recommended for stainless steel. Bakers Pride offers a stainless-steel cleaner made expressly for this purpose. Always rub with the grains and apply very light pressure. Rinse well.
- b) A thin coat of light oil will add to the appearance of the oven.

Oven Interior: (including Steel Deck)

Clean Only When The Oven Is Cold.

Use only the detergent solutions and cleaners that meet the national and/or local codes. Clean the steel deck, the ceiling and the walls of the baking chamber with a mild soap and water solution.

Do not use oven cleaners, caustic solutions or mechanical means as they will damage the interior aluminized surfaces.

Ceramic Bake Decks:

Heavy And Fragile! Handle Carefully!

- a) The bake decks should be cleaned by using a long-handled scraper and stiff wire brush. At the end of each day, turn the thermostat up to its maximum setting and let the oven sit at that temperature for at least 1/2 hour. This will burn off the food spilled onto the baking decks during the day's production and turn it into ash. This ash can be brushed off the next day before turning the oven on.



OPERATING INSTRUCTIONS

- b) The ceramic bake decks should be scraped and brushed during the day also to help keep them clean. To remove excessive crumbs or carbon, the baking decks and the oven cavity may be vacuumed when the oven is cold.

DO NOT USE WATER OR OTHER LIQUIDS ON THE BAKING DECKS AS THAT MAY CAUSE THEM TO CRACK.

After long use, heavily soiled bake decks may be cleaned by turning over after scraping down and brushing off. This will burn off the heavily soiled underside of the bake decks over time. This procedure may be repeated as needed.

Service And Troubleshooting

The ovens are designed to be as trouble free as possible. Keeping the oven clean is about all that is normally required. However, if your oven stops operating, check the following:

- a) The thermostat, to see if the set temperature has been reached and the thermostat has turned off the power to the heat control switches, indicator lamps, contactors and heating elements.
- b) The infinite top and bottom heat control switches, to see if they are "on". They must be in a set position (other than off) for indicator lamps, contactors and heating elements to operate.
- c) The power supply fuses/ breakers, to see if they are blown / or have tripped.
- d) The two branch protection fuses in the control panel of the oven, to see if one or both of them are blown.

If the oven still does not operate, disconnect the power supply to the unit by turning off the main switch, then contact the factory, factory representative or an authorized service agency.

All servicing should be performed by a factory authorized technician only.

Every six months (more frequently if the oven is used heavily) the door spring mechanism and all moving parts must be inspected for wear. If necessary, apply some lubricants to the door pins and bearing blocks at each side of the oven door. Use only lubricants that meet the national and/or local codes.

DO NOT APPLY GREASE OR OIL TO SPRING LEVER SHOULDER BOLT AND SPRING ROLLER, THEY HAVE SELF-LUBRICATING INSERTS THAT WILL BE DAMAGED IF LUBRICATED.



FLOOR MODEL ELECTRIC DECK OVEN OPERATION MANUAL

OPERATING INSTRUCTIONS

Troubleshooting Chart

Problem	Probable Cause	Remedy
Indicator light is out	Set temperature has been reached.	Take no action. The thermostat has turned off the power to the heat switches, indicator and heating elements. When oven starts to cool, all functions will be restored.
	The infinite top and bottom heat control switches are "OFF".	Turn switches to a position other than "OFF". This will allow indicator lamps, contactors and heating elements to operate.
	One or both branch protection fuses in the	Replace fuse(s).
No power	Power supply fuses or circuit breakers are blown or have been tripped.	Replace fuse or reset circuit breaker.
Oven too Hot	Thermostat set too high.	Lower the thermostat setting. Allow several hours for heat to regulate.
	Thermostat may be defective.	Call local authorized Bakers Pride service agent.
Bottom of pies are undercooked	If the same area of the deck is used repeatedly, the deck temperature in that area will be reduced.	Rotate pies to unused areas of the bake deck that are hotter and will cook the bottoms faster.
	Bottom infinite switch set too low.	Increase setting.
	Top infinite switch set too high.	Decrease setting.
Bottom of pies burn before toppings are cooked	Deck temperature too hot - especially during slow periods	Reduce Thermostat setting by 50°-75° below normal bake temperature. When decks cool begin cooking and immediately increase the thermostat setting by 50° - 75°.
	Bottom infinite switch set too high.	Decrease setting.
	Top infinite switch set too low.	Increase setting.
Pies cook unevenly	Exhaust fan may be too powerful.	Reduce fan speed.
	Areas adjacent to oven walls are generally hotter.	Rotate pies (180°), once during each bake or keep to the center of oven.
	Sometimes the left rear is not cooking as fast as the rest of the oven because the moisture vent is open.	Close the moisture vent.

Rating Plate

A copy of the rating plate is enclosed. Please keep for future reference.

For further information and to purchase the deck scraper/brush, or stainless steel cleaner, call Bakers Pride toll-free at: (800) 431-2745.

Model Number: _____

Serial Number: _____

Voltage: _____

Phase: _____

Date Code: _____

Date Purchased: _____

Purchased From: _____

Please fill in the above rating plate information and keep for future reference.

This information will be necessary in the future when ordering parts or requesting warranty service.

BAKERS PRIDE OVEN CO., INC.
 NEW ROCHELLE, NEW YORK, U.S.A.
 COMMERCIAL ELECTRIC COOKING APPLIANCE
 EQUIPEMENT DE TRAITERIE OPERANT AU ELECTRIQUE

MODEL NO. _____ SERIAL NO. _____
 VOLTAGE _____ PHASE _____
 DATE CODE _____ DATE PURCHASED _____

CAUTION: USE COPPER SUPPLY WIRE AS SPECIFIED BY THE MANUFACTURER'S INSTRUCTIONS. EMPLOYER USE FILS D'ALUMINIUM EN CONFORMITE AVEC LES INSTRUCTIONS DU MANUFACTURIER.

1 2 3 4 5 6 7 8 9 10 11 12

SEE CONNECTION DIAGRAM BEFORE ACCEPTABLE CLEARANCE FROM OVERHEAD OR UNDERGROUND LINES. *FOR SCHEMATA DE BRANCHEMENT AVANT D'ACCEPTER LA CLAIRANCE DES LIGNES AERIENNES OU CABLES ENFONDES.

INSTALLATION: TO BE INSTALLED IN A WELL VENTILATED PLACE. ONLY PERMITTED TO BE INSTALLED IN A WELL VENTILATED PLACE. *INSTALLER TO BE RESPONSIBLE FOR THE PROPER INSTALLATION OF THE EQUIPMENT. L'INSTALLATION DE L'EQUIPEMENT DOIT SE FAIRE DANS UN ENDROIT BIEN VENTILE. SEUL LE MANIPULANT EST RESPONSABLE DE LA BIEN INSTALLATION DE L'EQUIPEMENT.

THIS EQUIPMENT IS TO BE INSTALLED TO COMPLY WITH THE APPLICABLE NATIONAL, STATE, OR LOCAL PLUMBING CODES. CET EQUIPEMENT DOIT ETRE INSTALLE EN CONFORMITE AVEC LES CODES DE PLUMBING APPLICABLES NATIONAUX, ETATIS, EN VILLE.

ONLY PERMITTED TO BE INSTALLED IN A WELL VENTILATED PLACE. SEUL L'INSTALLATEUR EST RESPONSABLE DE LA BIEN INSTALLATION DE L'EQUIPEMENT.

CAUTION: DISCONNECT POWER BEFORE CHANGING DE VOLTAGE, PHASE, OR WIRE SIZE. ATTENTION: DEBRANCHEZ LE CABLE D'ALIMENTATION AVANT DE CHANGER LE VOLTAGE, LA PHASE, OU LA TAILLE DES CABLES.

RECOMMENDED FOR DIRECT THERMOCOIL HEATING. RECOMMANDE POUR CHAUFFAGE DIRECT PAR COILS ELECTRIQUES.

UL LISTED CE

OPERATING INSTRUCTIONS

Parts List and Exploded View

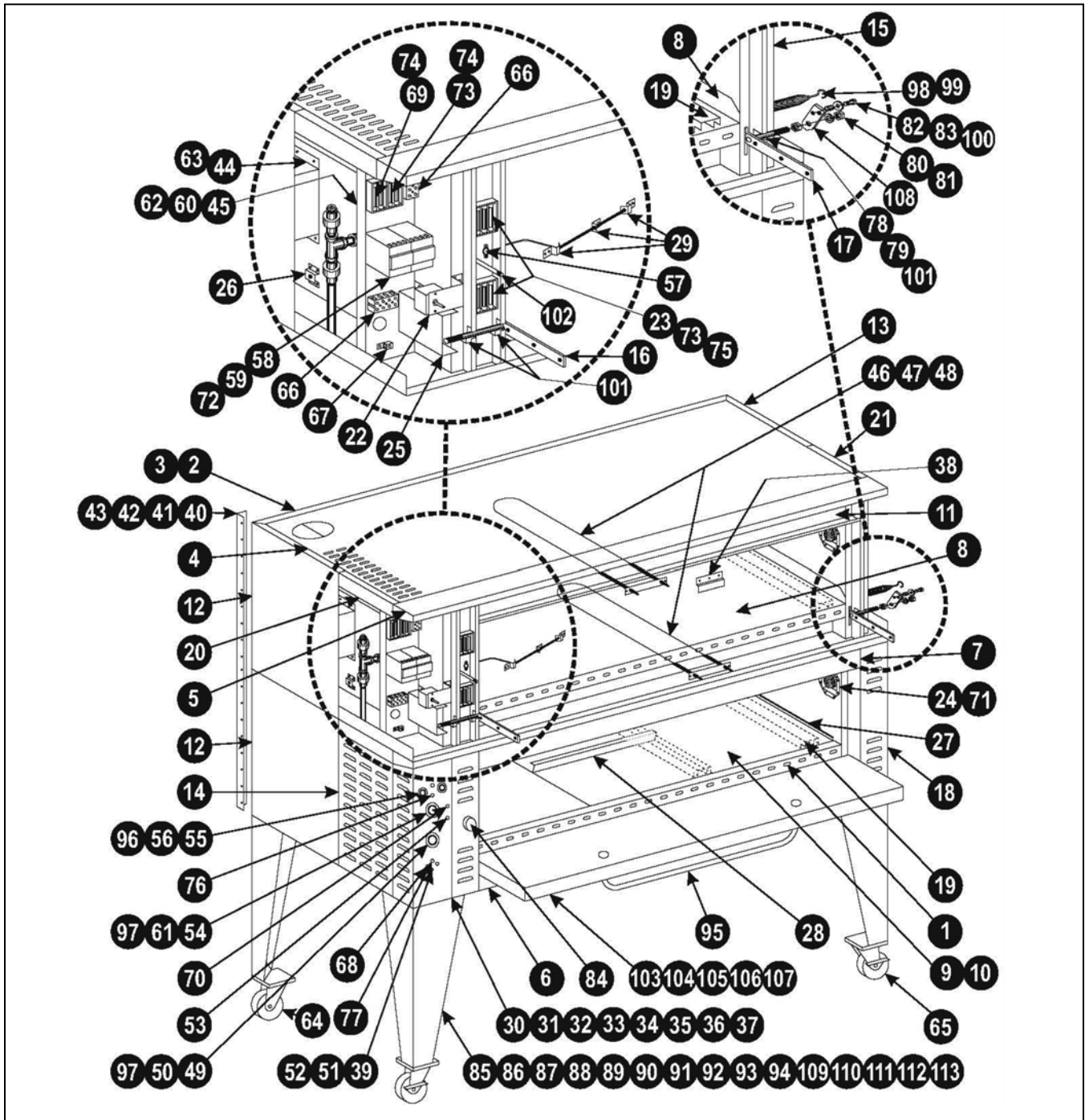

Exploded View: EP, EB & ER Electric 3836/5736 Deck Oven



FLOOR MODEL ELECTRIC DECK OVEN OPERATION MANUAL

OPERATING INSTRUCTIONS

Item	3836	5736	Description
1	C4038K	C4039K	Deck Trim
2	C4049U	C4050U	Outer Back Asm 8"
3	C4142U	C4143U	Outer Back Asm 12"
4	C4056U	C4057U	Outer Top Asm
5	C4067K	C4068K	Top Trim
6	C4077K	C4078K	Bottom Apron
7	C4079K	C4080K	Top Apron
8	T1224U	T1225U	Steel Deck Asm
9	T1232Y	T1232X	Hearth Baking Deck (Set/2-3836 / Set/3-5736)
10	T1232A	T1232A	Hearth Baking Deck 19 x 36 x 1 (each)
11	S6060Y	S6060X	Insulation Needed Blanket 1"
Item	8"	12"	Description
12	C4047K	C4140K	Outer Side LH
13	C4048K	C4141K	Outer Side RH
14	C4053K	C4144K	Access Cover LH
15	C4054K	C4145K	Access Cover RH
16	S3242U	S3244U	Door Arm Asm LH
17	S3243U	S3245U	Door Arm Asm RH
18	C4076K	C4146K	Front Column RH

Item	All Models	Description
19	C4040K	Deck Support
20	C4059K	Side Top Trim LH (All)
21	C4060K	Side Top Trim RH (All)
22	C4069K	Thermostat Bracket
23	C4070U	Fuse Block Bracket Asm
24	C4071K	Lamp Mount
25	C4074K	Spring Guard
26	C4075U	Spring Bracket Asm
27	C4109K	Deck Spacer 36"
28	C4110K	Deck Spacer Back 19"(3836-2 needed, 5736-3 needed)
29	C4098X	Capillary Clip Kit
30	C4100K	Control Panel - Pizza 8" 680F
31	U1352A	Overlay (for C4100K)
32	C4089K	Control Panel -Bake 8" 550°F 60 Minute
33	U1353A	Overlay (for C4089K)
34	C4091K	Control Panel -Roast 12" 550°F 60 Minute
35	U1355A	Overlay (for C4091K)
36	C4093K	Control Panel -Roast 12" 550°F 5 Hour
37	U1354A	Overlay (for C4093K)
38	C4095K	Steel Deck Clip (3836-2 needed, 5736-3 needed)
39	C4103K	Steam Control Bracket
40	C4105K	Stacking Bracket E-PB-2 (set/2) w/Screws
41	C4106K	Stacking Bracket E-R-2 (set/2) w/Screws
42	C4107K	Stacking Bracket E-PB-3 (set/2) w/Screws
43	C4108K	Stacking Bracket E-R-3 (set/2) w/Screws
44	C4113U	Transformer Bracket Asm
45	C4161K	Solenoid Bracket
46	L1178A	Heater Element 1000W 230V (each) w/Cap
47	L1179A	Heater Element 1000W 208V (each) w/Cap
48	L1180A	Heater Element 1000W 460V (each) w/Cap
49	M1192A	Thermostat 3 Pole 800F 300V 16A
50	M1369A	Thermostat 3 Pole 550F 300V 16A
51	M1176A	Potentiometer (Steam)
52	M1231A	Timer SS (Steam)

Item	All Models	Description
53	M1259A	Toggle Switch DPST on-off 250/125V 10/15 A (Light)
54	M1382A	Electric Timer, 250V, 60 Minute
55	M1367A	Infinite Switch 208V 25A (Top & Bottom Heat Control)
56	M1368A	Infinite Switch 240V 25A (Top & Bottom Heat Control)
57	M1370A	Hi-Limit Switch 140C 240/120V 10/15A
58	M1371A	Contactora 4 Pole 600V 25A 208V 50/60Hz
59	M1372A	Contactora 4 Pole 600V 25A 220-240V 50/60 Hz
60	M1387A	Solenoid Valve 1/2B 1/2P
61	M1374A	Electric Timer 250V 5 Hour
62	M1388A	Solenoid Coil 208-240V 50/60Hz
63	M1376A	Transformer 480/240V 0.25KVA
64	S1022X	Caster 4" No Lock (each)
65	S1023X	Caster 4" w/Lock (each)
66	P1004A	Terminal Block 4 Pole 600V 85A
67	P1025A	Grounding Lug 140A
68	P1098A	PB Switch SPST Mom Contact 2501125V3/6A(Steam)
69	P1118A	Fuse KTK Class CC 600V 10A
70	P1128A	Indicator Lamp 1/2" 250V 113W Green (Timer)
71	P1145A	Lamp Asm 240V 15W
72	P1150A	Mounting Strip for Contactors
73	P1164A	Fuse KTK Class CC 600V 30A
74	P1165A	Fuse Block 2 Pole 600V 30A
75	P1166A	Fuse Block 3 Pole 600V 30A
76	P1167A	Indicator Lamp 1/2" 250V 1/3 W/Amber (Heat selector)
77	P1168A	Indicator Lamp 1/2" 250V 113W Red (Steam)
78	Q3001A	Flat Washer 19/32 x 1" x 1/8 (2)
79	Q3002A	Flat Washer 19/32 x 1" x 1/16 (4)
80	Q3007A	Split Lock Washer 9/16 (Door Rod)
81	Q2401A	Hexagon Nut 9/16-18 (Door Rod)
82	Q3010A	Flat Washer 7/16 x 1" x 5/64 (Bushing/Sleeve)
83	Q2301A	Shoulder Bolt 3/8-16 x 1" (Bushing/Sleeve)
84	S1005A	Push-Pull Knob 3/8-16 (Vent)
85	S1018Y	Legs 12" (Set/4 w/Bolts & Washers)
86	S1018T	Leg 12" (each) w/Bolts & Washers
87	S1004Y	Legs 30" (Set/4) w/Bolts & Washers
88	S1004X	Leg 30" (each) w/Bolts & Washers
89	S1406Y	Legs 36" (Set/14) w/Bolts & Washers
90	S1406A	Leg 36" (each) w/Bolts & Washers
91	S1019Y	Legs 6" (Set/4) w/Bolts & Washers
92	S1019T	Leg 6" (each) w/Bolts & Washers
93	S1251Y	Legs 24" (Set/4) w/Bolts & Washers
94	S1251A	Leg 24" (each) w/Bolts & Washers
95	S1196A	Door Handle 30" w/Screws
96	S1205A	Knob 1/4 D (Heat Selector)
97	S1311A	Knob 1/4 D (Timer/Thermostat)
98	S3004A	Door Spring 13/16 x 6-3/4
99	S3003A	Door Spring 1-1/8 x 9-3/4
100	S3108A	Bushing/Sleeve Asm
101	S3239A	Bearing Block 1 x 1 x 1/2 Bronze
102	S3241A	Flue Rod 3/8-16 x 37"
103	U1043A	Bakers Pride Logo 13-1/4
104	C4085T	Door Asm 3836-8" w/o Door Arm Asm's
105	C4086T	Door Asm 5736-8" w/o Door Arm Asm's
106	C4151T	Door Asm 3836-12" w/o Door Arm Asm's
107	C4152T	Door Asm 5736-12" w/o Door Arm Asm's
108	A3295E	Spring Lever
109	S1075X	S/S Leg Wrap 6" (Set/2)
110	S1076X	S/S Leg Wrap 12" (Set/2)
111	S1331X	S/S Leg Wrap 24 1/2" (Set/2)
112	S1078X	S/S Leg Wrap 30" (Set/2)
113		S/S Leg Wrap 30" (Set/2)

Note: When ordering parts, ALWAYS specify Part Number, Model Number, Serial Number, and Voltage/Phase.

OPERATING INSTRUCTIONS

Wiring Diagrams

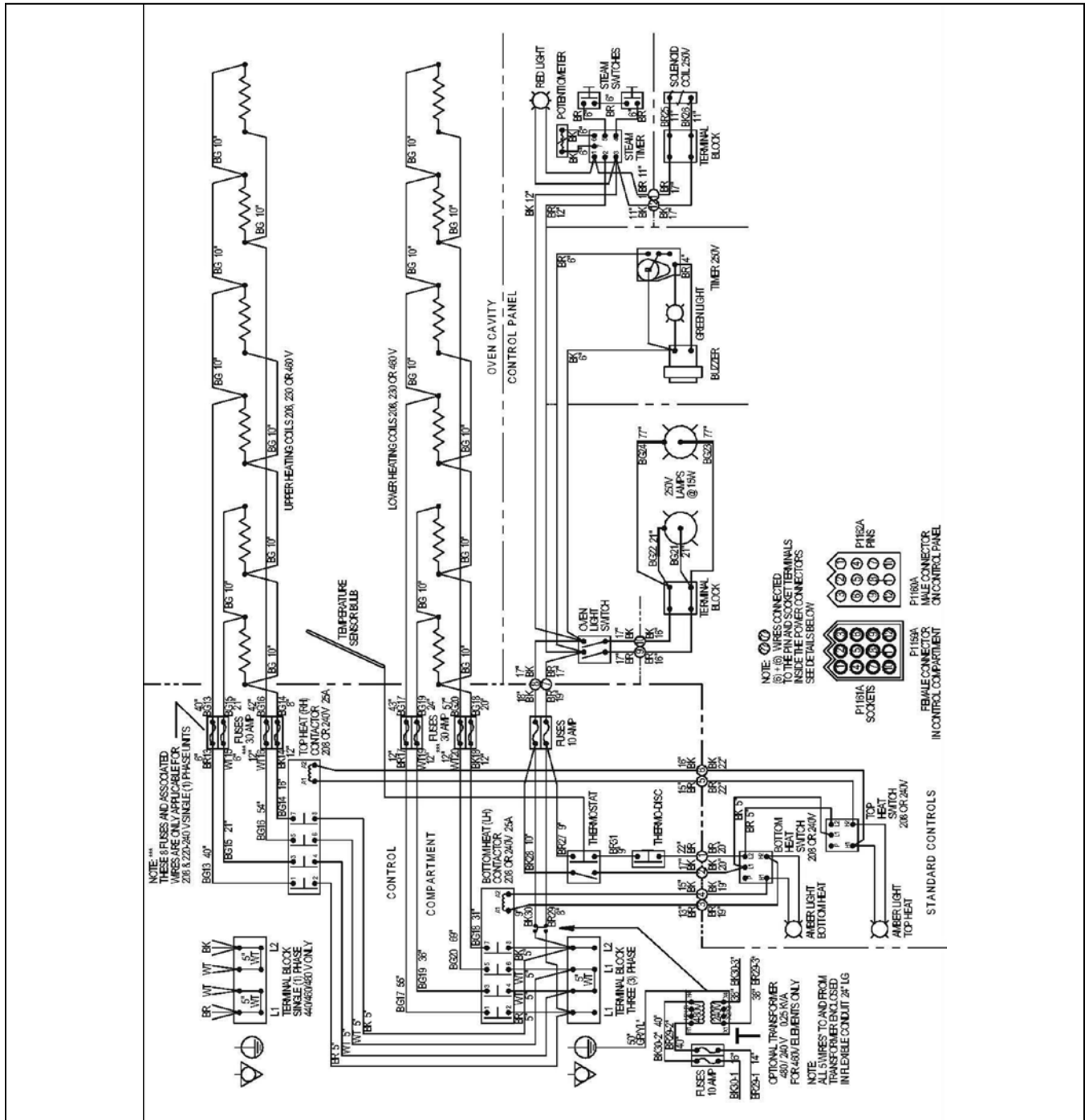

Wiring Diagram: EP(B,R) -8(12) -5736 208, 240 or 440-480V, 1PH, 2W or 3PH, 3W

OPERATING INSTRUCTIONS

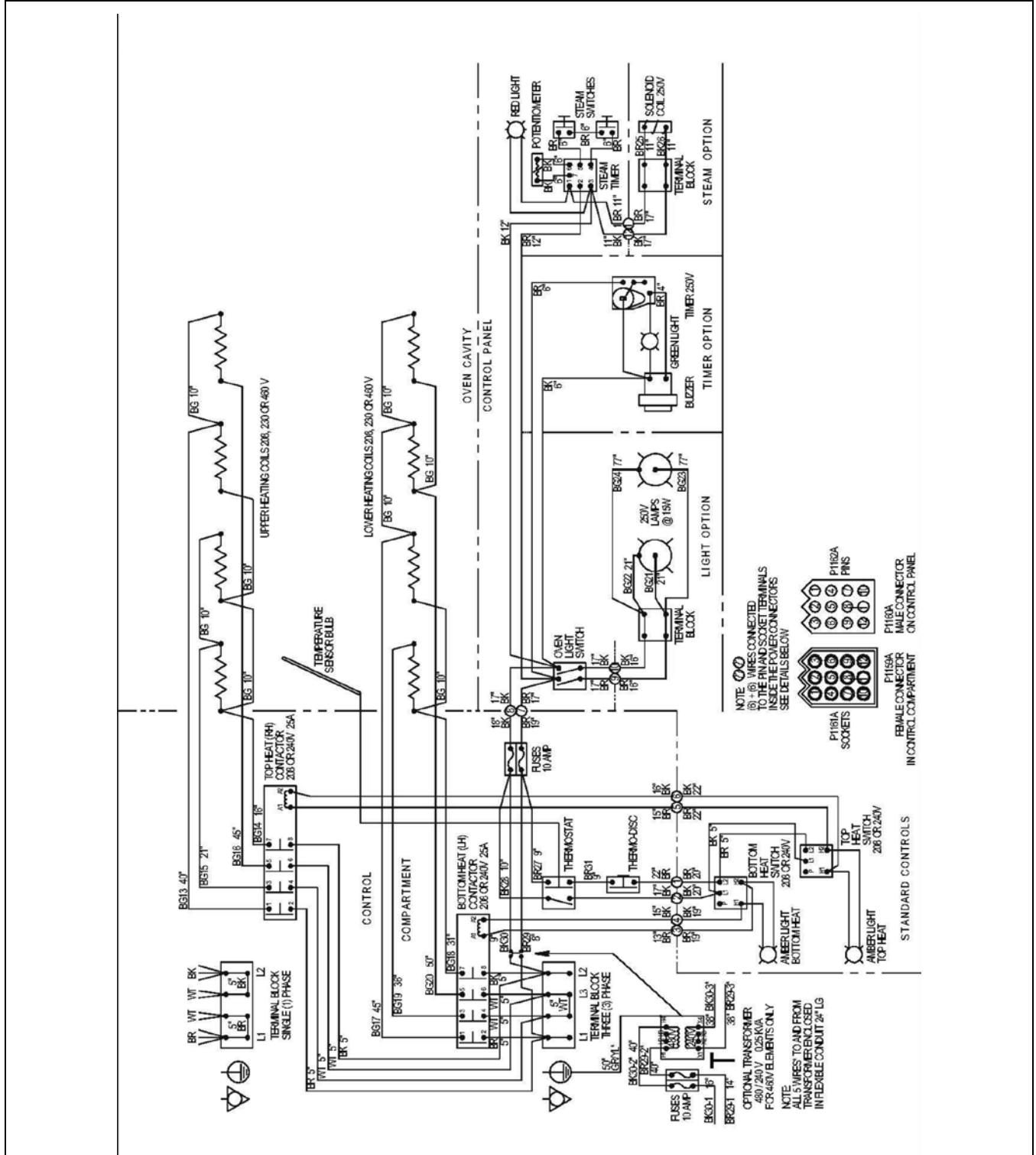

Wiring Diagram EP(B,R) -8(12) -3836 208, 240 or 440-480V, 1PH, 2W or 3PH, 3W

OPERATING INSTRUCTIONS

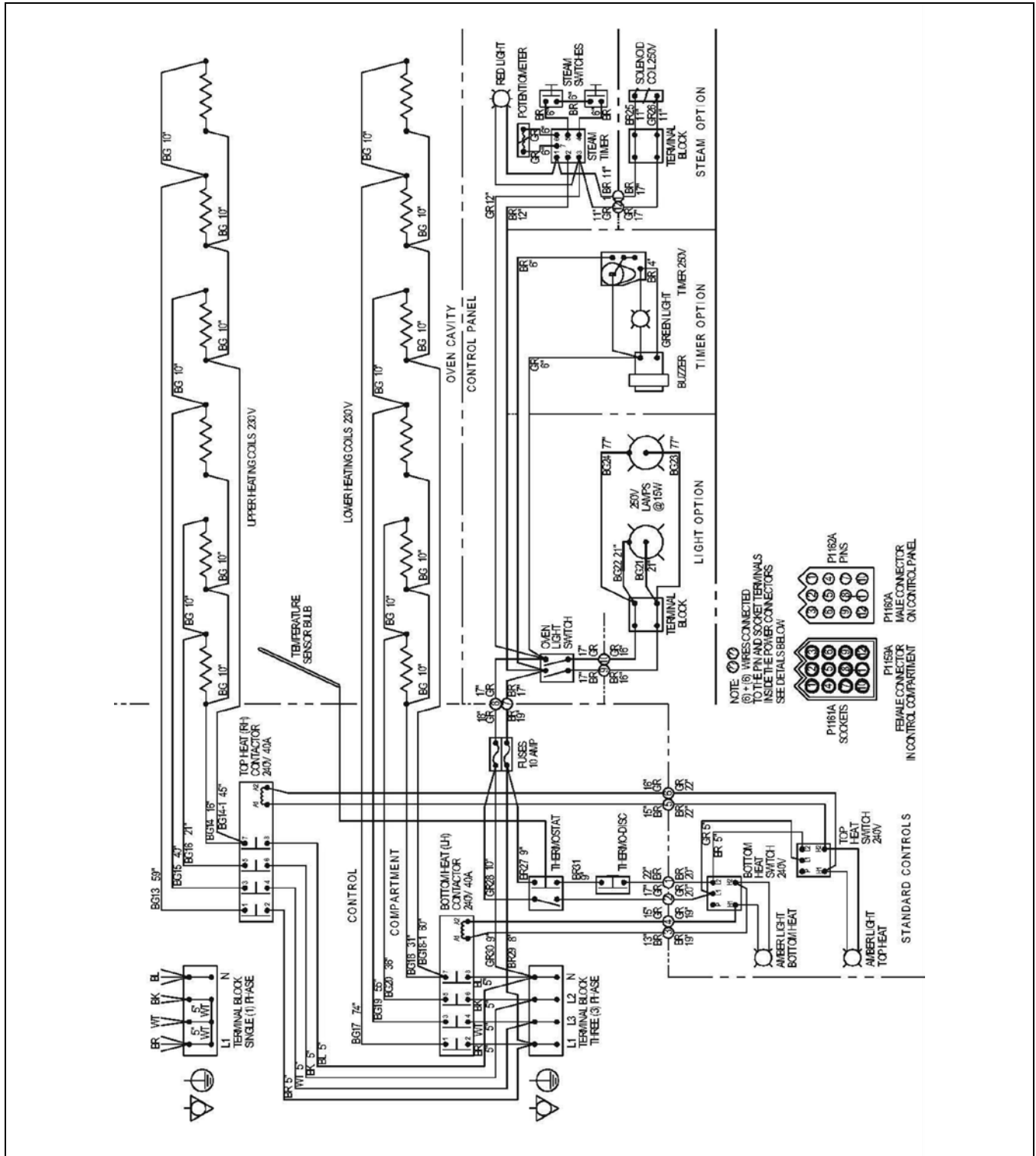

Wiring Diagram: EP(B,R) -8(12) -5736 230/400V – STAR

OPERATING INSTRUCTIONS

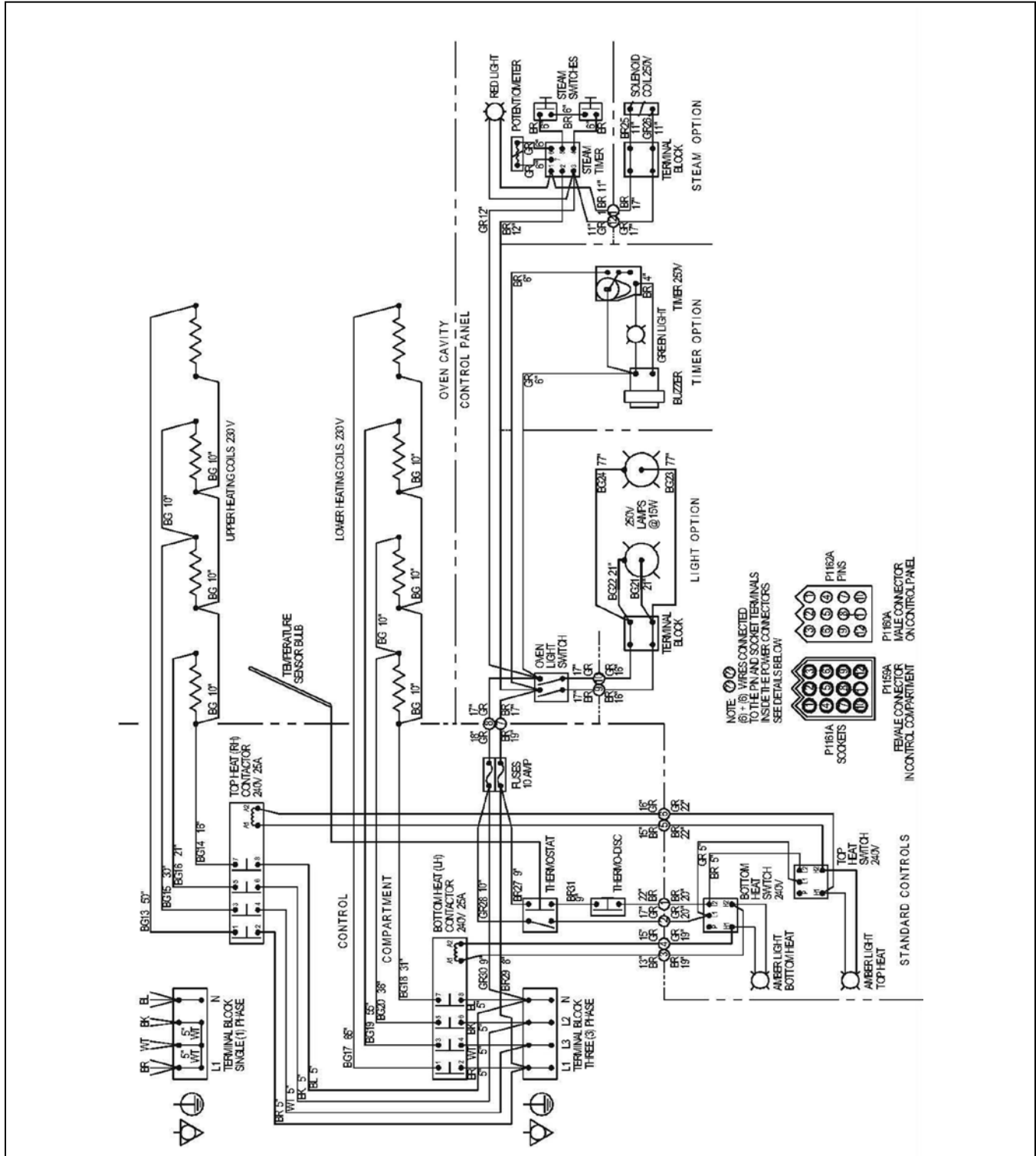

Wiring Diagram EP(B,R) -8(12) -3836 230/400V - STAR



BAKERS PRIDE LIMITED WARRANTY

WHAT IS COVERED	<p>This warranty covers defects in material and workmanship under normal use, and applies only to the original purchaser providing that:</p> <ul style="list-style-type: none">• The equipment has not been accidentally or intentionally damaged, altered or misused;• The equipment is properly installed, adjusted, operated and maintained in accordance with National and local codes and in accordance with the installation instruction provided with the product;• The serial number rating plate affixed to the equipment has not been defaced or removed.
WHO IS COVERED	<p>This warranty is extended to the original purchaser and applies only to equipment purchased for use in the U.S.A.</p>
COVERAGE PERIOD	<p>Cyclone Convection Ovens: BCO Models: One (1) Year limited parts and labor; (1) Year limited door warranty. GDCO Models: Two (2) Year limited parts and labor; (2) Year limited door warranty. CO11 Models: Two (2) Year limited parts and labor; (5) Year limited door warranty. All Other Products: One (1) Year limited parts and labor. Warranty period begins the date of dealer invoice to customer or ninety (90) days after shipment date from Bakers Pride - whichever comes first.</p>
WARRANTY	<p>This warranty covers on-site labor, parts and reasonable travel time and travel expenses of the authorized service</p>
COVERAGE	<p>Representative up to (100) miles, round trip, and (2) hours travel time. The purchaser, however, shall be responsible for all expenses related to travel, including time, mileage and shipping expenses on smaller counter models that may be carried into a Factory Authorized Service Center, including the following models: PX-14, PX-16, P18, P22S, P24S, PD-4, PDC, WS Series and BK-18.</p>
EXCEPTIONS	<p>All removable parts in Bakers Pride® cooking equipment, including but not limited to: Burners, Grates, Radiants, Stones and Valves, are covered for a period of SIX MONTHS. All Ceramic Baking Decks are covered for a period of THREE MONTHS. The installation of these replacement decks is the responsibility of the purchaser. The extended Cyclone door warranty years 3 through 5 is a parts only warranty and does not include labor, travel, mileage or any other charges.</p>
EXCLUSIONS	<ul style="list-style-type: none">• Negligence or acts of God,• Failures caused by erratic voltages or gas supplies,• Thermostat calibrations after (30) days from equipment installation date,• Unauthorized repair by anyone other than a Bakers Pride Factory Authorized Service Center,• Air and Gas adjustments,• Damage in shipment,• Light bulbs,• Alteration, misuse or improper installation,• Glass doors and door adjustments,• Thermostats and safety valves with broken capillary tubes,• Fuses,• Char-broiler work decks and cutting boards,• Tightening of conveyor chains,• Adjustments to burner flames and cleaning of pilot burners,• Tightening of screws or fasteners,• Accessories — spatulas, forks, steak turners, grate lifters, oven brushes, scrapers, peels. etc.,• Freight — other than normal UPS charges,• Ordinary wear and tear.
INSTALLATION	<p>Leveling and installation of decks as well as proper installation and check out of all new equipment —per appropriate installation and use materials — is the responsibility of the dealer or installer, not the manufacturer.</p>
REPLACEMENT PARTS	<p>Bakers Pride genuine Factory OEM parts receive a (90) day materials warranty effective from the date of installation by a Bakers Pride Factory Authorized Service Center.</p>

This Warranty is in lieu of all other warranties, expressed or implied, and all other obligations or liabilities on the manufacturer's part. Bakers Pride shall in no event be liable for any special, indirect or consequential damages, or in any event for damages in excess of the purchase price of the unit. The repair or replacement of proven defective parts shall constitute a fulfillment of all obligations under the terms of this warranty.

Standex

Food Service Equipment Group

The Standex Food Service Equipment Group (FSEG) is a manufacturer of innovative commercial food service equipment offering a wealth of refrigeration and cooking expertise. Products include walk-in coolers and freezers; hot and cold display cabinets, cases, and storage systems; commercial ovens, rotisseries, and cooking equipment; and rotary vane pumps.

Ask your sales representative about how the power of all Standex brands can work for you.
www.standex.com/segments/food-service



Be sure to keep up with new product announcements and events on social media!

