



INSTALLATION AND OPERATING INSTRUCTIONS

# Condiment Dispenser Pump

**MODELS: DSTI-X & DCSTI-X**

## PRODUCT MANUAL

Operation Instructions  
Adjustment Instructions  
Cleaning Instructions  
Replacement Parts List  
Warranty/Service Information

**24 Hour Toll Free**



**Service Hot Line:  
1-800-733-2203**

### IMPORTANT FOR FUTURE REFERENCE

Please complete this information and retain this manual for the life of the equipment. For Warranty Service and/or Parts, this information is required.

\_\_\_\_\_   
Model Number

\_\_\_\_\_   
Serial Number

\_\_\_\_\_   
Date Purchased

P/N 88722-00 9/05

**APW WYOTT Foodservice Equipment Company**

P.O. Box 1829  
Cheyenne, WY 82003

+1 (307) 634-5801 Phone  
+1 (307) 637-8071 Fax

+1 (800) 752-0863 Toll Free  
[www.apwwyott.com](http://www.apwwyott.com)

## Instructions for Operating, Adjusting & Cleaning the DSTI-X & DCSTI-X Condiment Dispenser Pump

NOTE: Clean the pump thoroughly in a sanitizing solution before using it for the first time.

### Operation:

To operate the pump, press the lever knob down until it stops; then release it. A brisk, smooth stroke delivers the condiment uniformly.

### Adjustment:

Adjust the pump to deliver the amount of condiment you require. Depending on the condiment, the pump can dispense up to about 1 ½ ounces with one stroke.

1. Turn the pump knob counterclockwise and remove it.
2. Turn the upper spring cage clockwise for a smaller portion of condiment and counterclockwise for a larger portion.
3. Replace the pump knob tightly.

### Cleaning:

Clean the pump **daily** according to the instructions below. ***Note the way the pump comes apart so you can reassemble it in reverse order.***

1. Remove the hairpin clip on the bottom of the pump.
2. Remove the cup.
3. Remove the intake valve.
4. Turn the pump knob counterclockwise and remove it.
5. Turn the upper spring cage counterclockwise and remove it.
6. Remove the spring and lower spring cage.
7. Remove the piston.
8. Wash all pump parts thoroughly in a sanitizing solution, using the brush provided; rinse the parts in hot water and allow them to air dry.
9. Reassemble the pump using reverse Procedure.

**PLEASE PLACE THESE INSTRUCTIONS WHERE THEY MAY BE REFERRED  
TO BY THOSE PERSONS USING AND CLEANING THE PUMP**

## PARTS LISTS & EXPLODED VIEWS

### DCSTI-X PUMP

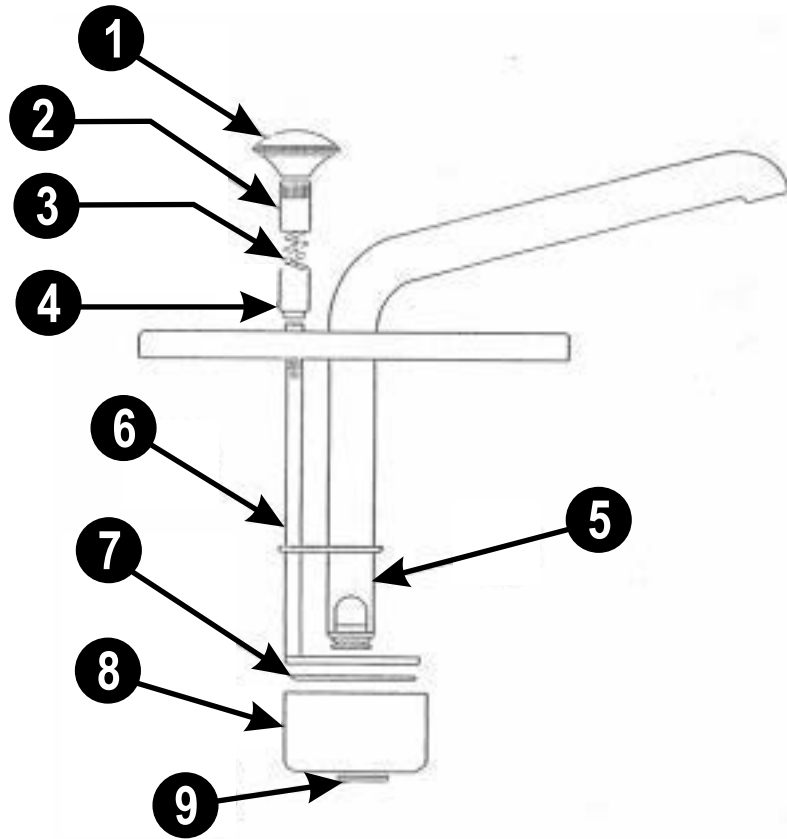

Item	P/N	Description	Quan
1	87043	Pump Knob	1
2	813	Upper Spring Cage	1
3	89110	Spring	1
4	40677	Lower Spring Cage	1
5	43422	Lid & Spout	1
6	43431	Piston Rod	1
7	43429	Intake Valve	1
8	42432	Cup	1
9	89905-01	Hairpin Clip	1
10	30247	Cleaning Brush (NOT SHOWN)	1

### DSTI-X PUMP

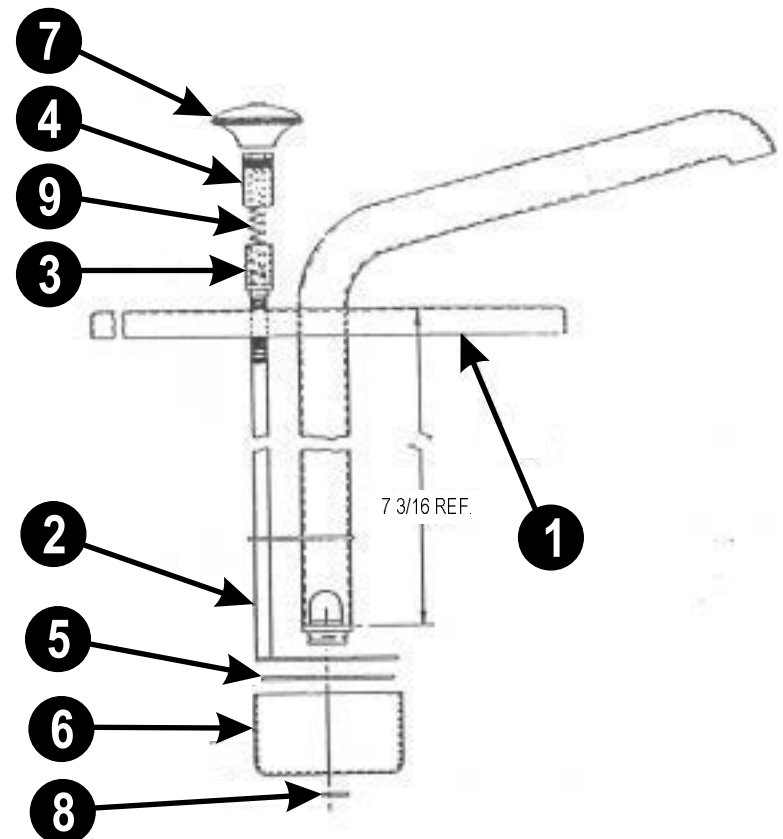

Item	P/N	Description	Quan
1	43422	Spout Tube Weldment	1
2	43431	Piston Rod Weldment	1
3	40677	Lower Spring Cage	1
4	813	Upper Spring Cage	1
5	43429	Intake Valve	1
6	43421	Cup	1
7	87043	Pump Knob	1
8	89905-01	Hairpin Clip	1
9	89110	Spring	1
10	30247	Cleaning Brush (NOT SHOWN)	1

## APW WYOTT EQUIPMENT LIMITED WARRANTY

APW Wyott Foodservice Equipment Company warrants its equipment against defects in materials and workmanship, subject to the following conditions:

This warranty applies to the original owner only and is not assignable.

Should any product fail to function in its intended manner under normal use within the limits defined in this warranty, at the option of APW Wyott such product will be repaired or replaced by APW Wyott or its Authorized Service Agency. APW Wyott will only be responsible for charges incurred or service performed by its Authorized Service Agencies. The use of other than APW Wyott Authorized Service Agencies will void this warranty and APW Wyott will not be responsible for such work or any charges associated with same. The closest APW Wyott Authorized Service Agent must be used.

This warranty covers products shipped into the 48 contiguous United States, Hawaii, metropolitan areas of Alaska and Canada. There will be no labor coverage for equipment located on any island not connected by roadway to the mainland.

Warranty coverage on products used outside the 48 contiguous United States, Hawaii, and metropolitan areas of Alaska and Canada may vary. Contact the international APW Wyott distributor, dealer, or service agency for details.

### Time Period

One year for parts and one year for labor, effective from the date of purchase by the original owner. The Authorized Service Agency may, at their option, require proof of purchase. Parts replaced under this warranty are warranted for the un-expired portion of the original product warranty only.

### Exceptions

- \***Gas/Electric Cookline:** Models GCB, GCRB, GF, GGM, GGT, CHP-H, EF, EG, EHP. Three (3) Year Warranty on all component parts, except switches and thermostats. (2 additional years on parts only. No labor on second or third year.)
- \***Broiler Briquettes, Rock Grates, Cooking Grates, Burner Shields, Fireboxes:** 90 Day Material Only. No Labor.
- \***Heat Strips:** Models FD, FDL, FDD, FDDL. Two (2) Year Warranty on element only. No labor second year.
- \***Glass Windows, Doors, Seals, Rubber Seals, Light Bulbs:** 90 Day Material Only. No Labor.

In all cases, parts covered by extended warranty will be shipped FOB the factory after the first year.

### Portable Carry In Products

Equipment weighing over 70 pounds or permanently installed will be serviced on-site as per the terms of this warranty. Equipment weighing 70 pounds or under, and which is not permanently installed, i.e. with cord and plug, is considered portable and is subject to the following warranty handling limitations. If portable equipment fails to operate in its intended manner on the first day of connection, or use, at APW Wyott's option or its Authorized Service Agency, it will be serviced on site or replaced.

From day two through the conclusion of this warranty period, portable units must be taken to or sent prepaid to the APW Wyott Authorized Service Agency for in-warranty repairs. No mileage or travel charges are allowed on portable units after the first day of use. If the customer wants on-site service, they may receive same by paying the travel and mileage charges. Exceptions to this rule: (1) countertop warmers and cookers, which are covered under the Enhanced Warranty Program, and (2) toasters or rollergrills which have in store service.

### Exclusions

The following conditions are not covered by warranty:

- \*Equipment failure relating to improper installation, improper utility connection or supply and problems due to ventilation.
- \*Equipment that has not been properly maintained, calibration of controls, adjustments, damage from improper cleaning and water damage to controls.
- \*Equipment that has not been used in an appropriate manner, or has been subject to misuse or misapplication, neglect, abuse, accident, alteration, negligence, damage during transit, delivery or installation, fire, flood, riot or act of god.
- \*Equipment that has the model number or serial number removed or altered.

If the equipment has been changed, altered, modified or repaired by other than an Authorized Service Agency during or after the warranty period, then the manufacturer shall not be liable for any damages to any person or to any property, which may result from the use of the equipment thereafter.

This warranty does not cover services performed at overtime or premium labor rates. Should service be required at times which normally involve overtime or premium labor rates, the owner shall be charged for the difference between normal service rates and such premium rates. APW Wyott does not assume any liability for extended delays in replacing or repairing any items beyond its control.

In all cases, the use of other than APW Wyott Authorized OEM Replacement Parts will void this warranty.

This equipment is intended for commercial use only. Warranty is void if equipment is installed in other than commercial application.

### Water Quality Requirements

Water supply intended for a unit that has in excess of 3.0 grains of hardness per gallon (GPG) must be treated or softened before being used. Water containing over 3.0 GPG will decrease the efficiency and reduce the operation life of the unit.

**Note: Product failure caused by liming or sediment buildup is not covered under warranty.**

**"THE FOREGOING WARRANTY IS IN LIEU OF ANY AND ALL OTHER WARRANTIES EXPRESSED OR IMPLIED INCLUDING ANY IMPLIED WARRANTY OF MERCHANTABILITY OR FITNESS FOR PARTICULAR PURPOSES AND CONSTITUTES THE ENTIRE LIABILITY OF APW WYOTT. IN NO EVENT DOES THE LIMITED WARRANTY EXTEND BEYOND THE TERMS STATED HEREIN."**

9/05