



**INSTALLATION
AND
OPERATING
INSTRUCTIONS**



Models: FDB, FDDB, FDLB & FDDL B

OVERHEAD FOODWARMERS

INTENDED FOR OTHER THAN HOUSEHOLD USE

**RETAIN THIS MANUAL FOR FUTURE REFERENCE
UNIT MUST BE KEPT CLEAR OF COMBUSTIBLES AT ALL TIMES**



FOR YOUR SAFETY: Do not store or use gasoline or other flammable vapors and liquids in the vicinity of this or any other appliance.



WARNING: Improper installation, adjustment, alteration, service or maintenance can cause property damage, injury or death. Read the Installation, Operating and Maintenance Instructions thoroughly before installing or servicing this equipment.



Initial heating of unit may generate smoke or fumes and must be done in a well ventilated area. Overexposure to smoke or fumes may cause nausea or dizziness.

This equipment has been engineered to provide you with year-round dependable service when used according to the instructions in this manual and standard commercial kitchen practices.



Phone: +1 (214) 421-7366
Fax: +1 (214) 565-0976
Toll Free: +1 (800) 527-2100
Website: www.apwwyott.com
E-mail: info@apwwyott.com

P/N 70499175 Rev. 9/05

APW WYOTT
729 Third Avenue
Dallas, TX 75226

TABLE OF CONTENTS

SECTION	ITEM	PAGE
1	General Information -----	2
2	Electrical Requirements -----	2
3	Electrical Specifications -----	3
4	Overall Dimensions -----	4
5	Installation -----	5
6	Operation -----	5
7	Cleaning -----	5
8	Troubleshooting -----	5
9	Wiring Diagrams -----	6
	A. FDB-120V -----	6
	B. FDC-208/240 -----	6
	C. FDLB-120V -----	7
	D. FDLB-208/240V -----	7
	E. FDLB-120V w/Fuse -----	8
	F. Fddb-120V -----	8
	G. Fddb-208/240V -----	9
	H. FDDLb-120V -----	9
	I. FDDLb-208/240V -----	10
	J. FDDLb-208/240 w/Fuse -----	10
10	Parts List & Exploded View -----	11
11	Warranty -----	14

1. GENERAL INFORMATION

- A. APW Wyott Overhead Foodwarmers are constructed from high quality stainless steel and available in lengths from 18" to 72". Utilizing a metal sheath heating element with a specially designed black aluminum extrusion, these units give uniform heat over the entire holding surface.

2. ELECTRICAL REQUIREMENTS

- A. Single phase operation at 120, 208, and 240 volts.
 B. Field-wired units provided with ½" conduit knockout and terminal blocks easily accessed through control box access plate. For supply connections, use minimum no. 14 AWG copper wires suitable for at least 90°C.

3. ELECTRICAL SPECIFICATIONS

STANDARD BLACK RADIANT OVERHEADS THERMOSTAT AND ROCKER SWITCH CONTROL						
MODEL	WATTS CIR-1	VOLTS - RATINGS				
		120	208	120/208	240	120/240
FDB-18	400	3.3	1.9	~	1.7	~
FDLB-18	480	4.0	~	2.6	~	2.3
FDDB-18	800	6.7	3.8	~	3.3	~
FDDLB-18	880	7.3	~	4.5	~	4.0
FDB-24	575	4.8	2.8	~	2.4	~
FDLB-24	655	5.5	~	3.4	~	3.1
FDDB-24	1150	9.6	5.5	~	4.8	~
FDDLB-24	1230	10.3	~	6.2	~	5.5
FDB-30	760	6.3	3.7	~	3.2	~
FDLB-30	840	7.0	~	4.3	~	3.8
FDDB-30	1520	12.7	7.3	~	6.3	~
FDDLB-30	1600	13.3	~	8.0	~	7.0
FDB-36	920	7.7	4.4	~	3.8	~
FDLB-36	1080	9.0	~	5.8	~	5.2
FDDB-36	1840	15.3	8.8	~	7.7	~
FDDLB-36	2000	16.7	~	10.2	~	9.0
FDB-42	1100	9.2	5.3	~	4.6	~
FDLB-42	1260	10.5	~	6.6	~	5.9
FDDB-42	2200	~	10.6	~	9.2	~
FDDLB-42	2360	~	~	11.9	~	10.5
FDB-48	1265	10.5	6.1	~	5.3	~
FDLB-48	1425	11.9	~	7.4	~	6.6
FDDB-48	2530	~	12.2	~	10.5	~
FDDLB-48	2690	~	~	13.5	~	11.9
FDB-54	1425	11.9	6.9	~	5.9	~
FDLB-54	1585	13.2	~	8.2	~	7.3
FDDB-54	2850	~	13.7	~	11.9	~
FDDLB-54	3010	~	~	15.0	~	13.5
FDB-60	1610	13.4	7.7	~	6.7	~
FDLB-60	1850	15.4	~	9.7	~	8.7
FDDB-60	3220	~	15.5	~	13.4	~
FDDLB-60	3460	~	~	* 17.5	~	15.4
FDB-66	1800	15.0	8.7	~	7.5	~
FDLB-66	2040	* 17.0	~	10.7	~	9.5
FDDB-66	3600	~	17.3	~	15.0	~
FDDLB-66	3840	~	~	* 19.3	~	* 17.0
FDB-72	1980	~	9.5	~	8.3	~
FDLB-72	2220	~	~	11.5	~	10.3
FDDB-72	3960	~	19.0	~	16.5	~
FDDLB-72	4200	~	~	* 21.0	~	* 18.5

*	REQUIRES 3 AMP FUSE
*	REQUIRES 30 AMP CIRCUIT

NOTE: TO AVOID BURNING OR CHARRING OF MATERIALS IN THE SURFACE BELOW THE FOODWARMER USE ONLY ABOVE AN ALL-METAL STRUCTURE SUCH AS A TABLE OR COUNTERTOP. SEE MINIMUM CLEARANCE CHART ABOVE.

REMOTE SWITCHES ARE RECOMMENDED FOR UNDER SHELF MOUNTING. LONGER SWITCH LIFE WILL RESULT FROM COOLER SWITCH MOUNTING LOCATIONS.

WARNING: ELECTRICAL SHOCK HAZARD. FAILURE TO FOLLOW THE INSTRUCTIONS IN THIS MANUAL COULD RESULT IN SERIOUS INJURY OR DEATH.

- Electrical Ground is required on this appliance.
- Do not modify the power supply cord plug. If it does not fit into the outlet, have the proper outlet installed by a qualified electrician
- Do not use an extension cord with this appliance.
- Check with a qualified electrician if you are unsure as to whether the appliance is properly grounded.

4. OVERALL DIMENSIONS

FDB / FDLB / FDDB / FDDL B MODELS

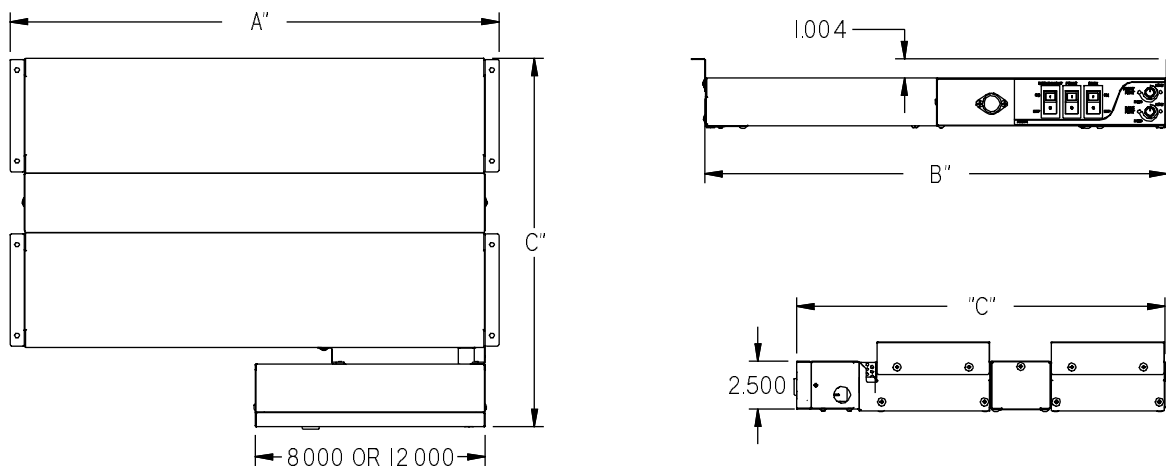

A"	B"	MODEL	C"	MODEL	C"	MODEL	C"
19.55	18.12	FDDB/FDDL B-18	19.26	FDLB-18	13.255	FDB-18	10.13
25.55	24.12	FDDB/FDDL B-24	19.26	FDLB-24	13.255	FDB-24	10.13
31.55	30.12	FDDB/FDDL B-30	19.26	FDLB-30	13.255	FDB-30	10.13
37.55	36.12	FDDB/FDDL B-36	19.26	FDLB-36	13.255	FDB-36	10.13
43.55	42.12	FDDB/FDDL B-42	19.26	FDLB-42	13.255	FDB-42	10.13
49.55	48.12	FDDB/FDDL B-48	19.26	FDLB-48	13.255	FDB-48	10.13
55.55	54.12	FDDB/FDDL B-54	19.26	FDLB-54	13.255	FDB-54	10.13
61.55	60.12	FDDB/FDDL B-60	19.26	FDLB-60	13.255	FDB-60	10.13
67.55	66.12	FDDB/FDDL B-66	19.26	FDLB-66	13.255	FDB-66	10.13
73.55	72.12	FDDB/FDDL B-72	19.26	FDLB-72	13.255	FDB-72	10.13

5. INSTALLATION

- A. Always clean equipment thoroughly before first use (See cleaning instructions).
- B. Provide the following clearances around foodwarmer:
 - 1. Single model minimum distance to non-combustible surface below = 4" to 10". Dual model minimum distance to non-combustible surface below = 8" to 14". For combustible surface, install the single and dual not closer than 13-1/2" to surface below.
 - 2. Minimum distance to side (end) walls = 2".
 - 3. Minimum distance to back walls = 2".
 - 4. Minimum distance to ceiling = 1".
- C. Consult foodwarmer rating label for model designation and correct operating voltage and amperage.
- D. Ceiling mounting brackets are provided with each foodwarmer for chain or shelf mounting. Remove brackets from packaging and screws from ends of foodwarmer to attach brackets. Use four #10 screws or studs with locknuts for shelf mounting. For chain mounting, use #14 jack chain and "S" hooks.
- E. Remote switches are recommended. Longer switch life will result from cooler switch mounting locations. Optional stainless steel remote units with 3/6 inch conduit are available. Installation of remote box by service personnel requires 14 AWG copper wires suitable for at least 90°C. Mount remote box to flat surface with 4 #10 screws or studs with locknuts. All wires marked as shown on wiring diagram. Mount remote box to flat surface with two #10 screws or studs with locknuts. All wires marked as shown on wiring diagram.
- F. Optional tubular stands are available for permanently mounting foodwarmers to non-combustible countertops.
- G. Optional portable legs are available for foodwarmers for use over non-combustible countertops.

6. OPERATION

- A. All foodservice equipment should be operated by trained personnel.
- B. Do not allow your customers to come in contact with any surface labeled "CAUTION HOT".
- C. Switch on unit. Place precooked product under heat source. Maximum heat coverage equivalent to unit length.
- D. Never hold food below 150°F.

7. CLEANING

- A. Never clean any electrical unit by immersing it in water.
- B. Never clean any electrical unit using water jets.
- C. Disconnect power before cleaning or servicing units.
- D. Clean unit daily. Use warm, soapy water. Mild cleansers and non-abrasive pads may be used to remove baked-on food.

8. TROUBLESHOOTING

- A. Always ask and check:
 - 1. Is the unit connected to a live power source?
 - 2. Check the circuit breaker.
 - 3. Is power switch on and pilot light illuminating?
 - 4. Check the rating label. Is the unit operating on proper voltage?
- B. If the above checks out, and problems still exist, call an APW Wyott authorized service agency.
- C. All service should be performed by an APW Wyott authorized service agency.

9. WIRING DIAGRAMS

A. FDB-120V WIRING DIAGRAM

FOR REMOTE MODELS
 LABEL LEAD WIRES AS SHOWN.
 LEADS TO BE 6" FROM HOUSING

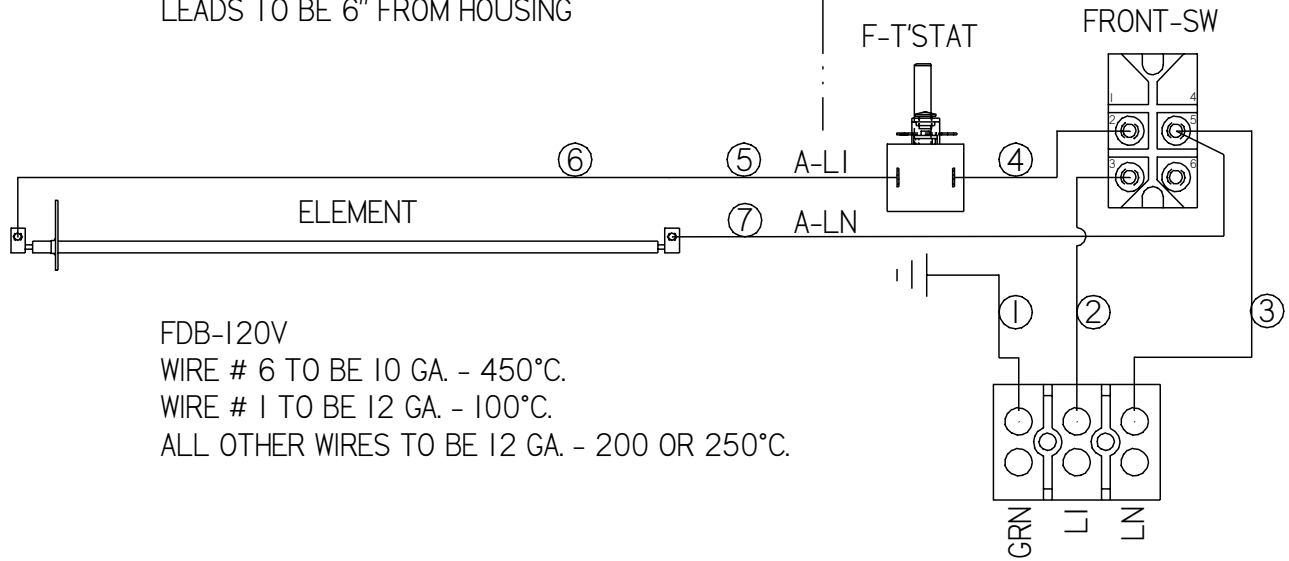

FDB-120V
 WIRE # 6 TO BE 10 GA. - 450°C.
 WIRE # 1 TO BE 12 GA. - 100°C.
 ALL OTHER WIRES TO BE 12 GA. - 200 OR 250°C.

B. FDB-208/240V WIRING DIAGRAM

FOR REMOTE MODELS
 LABEL LEAD WIRES AS SHOWN.
 LEADS TO BE 6" FROM HOUSING

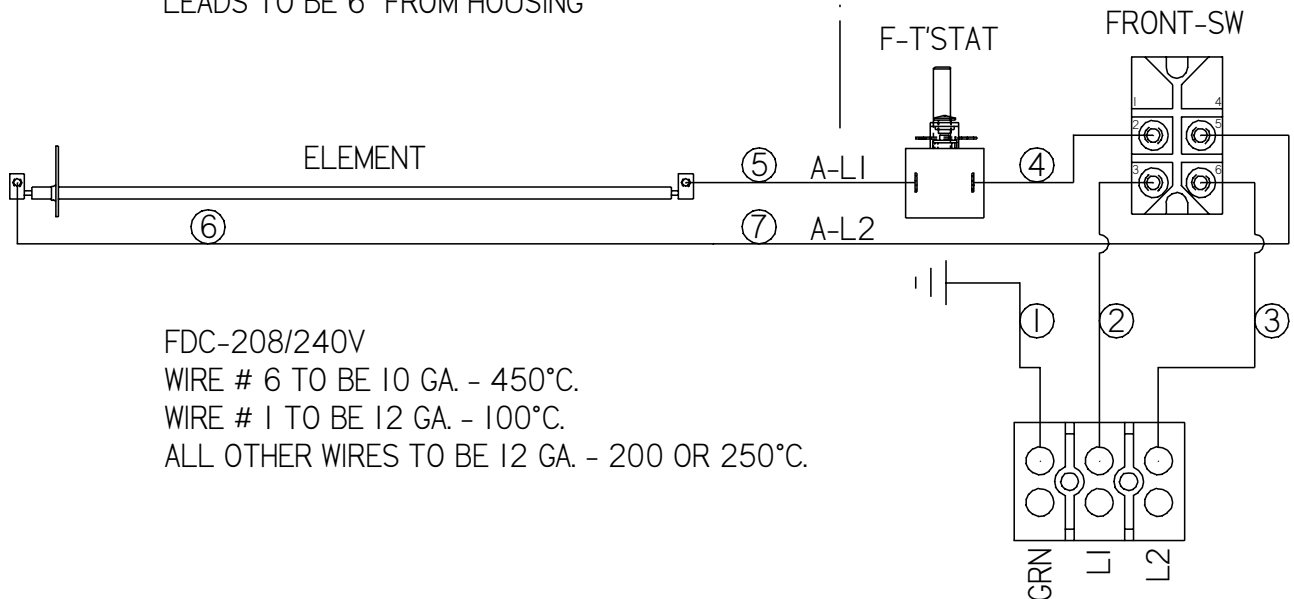

FDB-208/240V
 WIRE # 6 TO BE 10 GA. - 450°C.
 WIRE # 1 TO BE 12 GA. - 100°C.
 ALL OTHER WIRES TO BE 12 GA. - 200 OR 250°C.

C.

FDLB-120V WIRING DIAGRAM

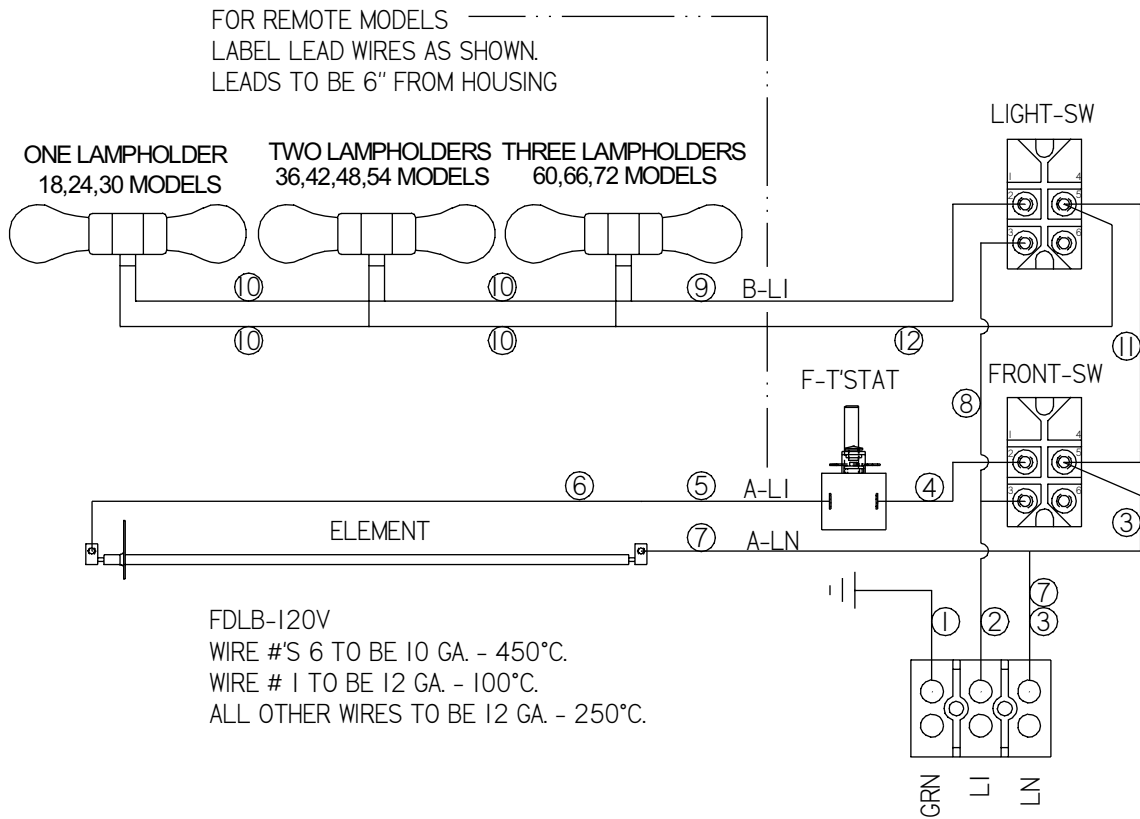

D.

FDLB-208/240V WIRING DIAGRAM

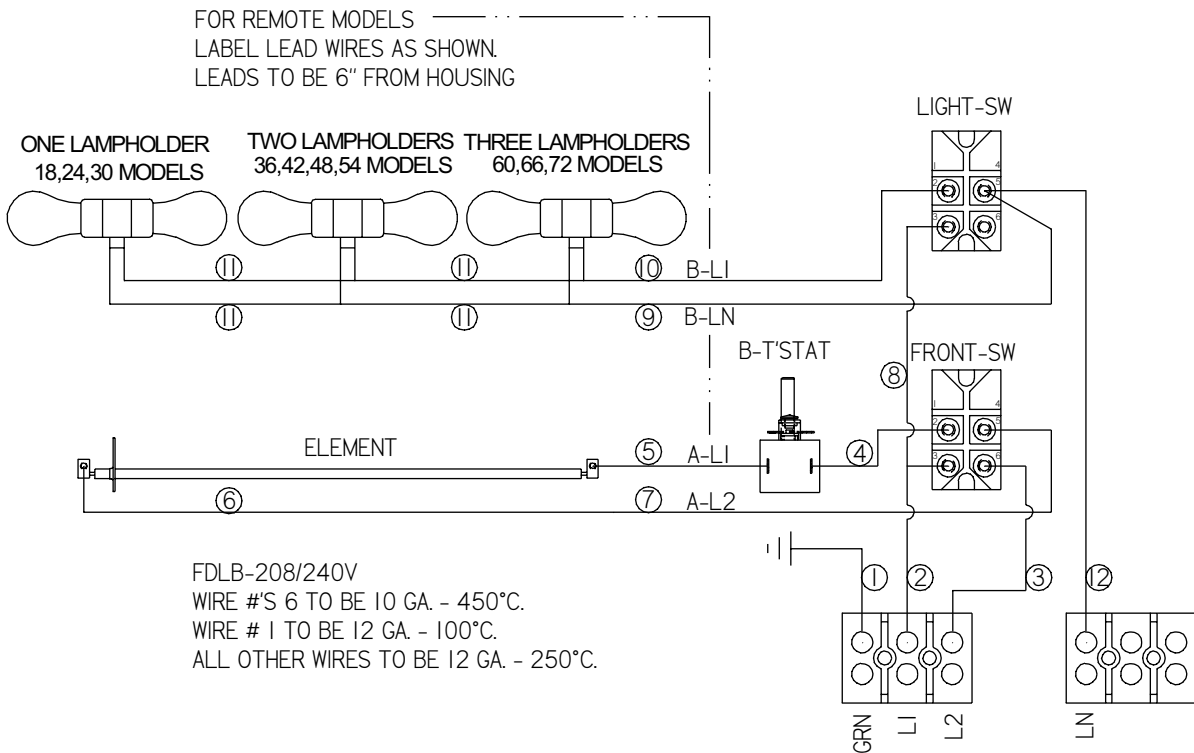

E. FDLB-120V w/FUSE WIRING DIAGRAM

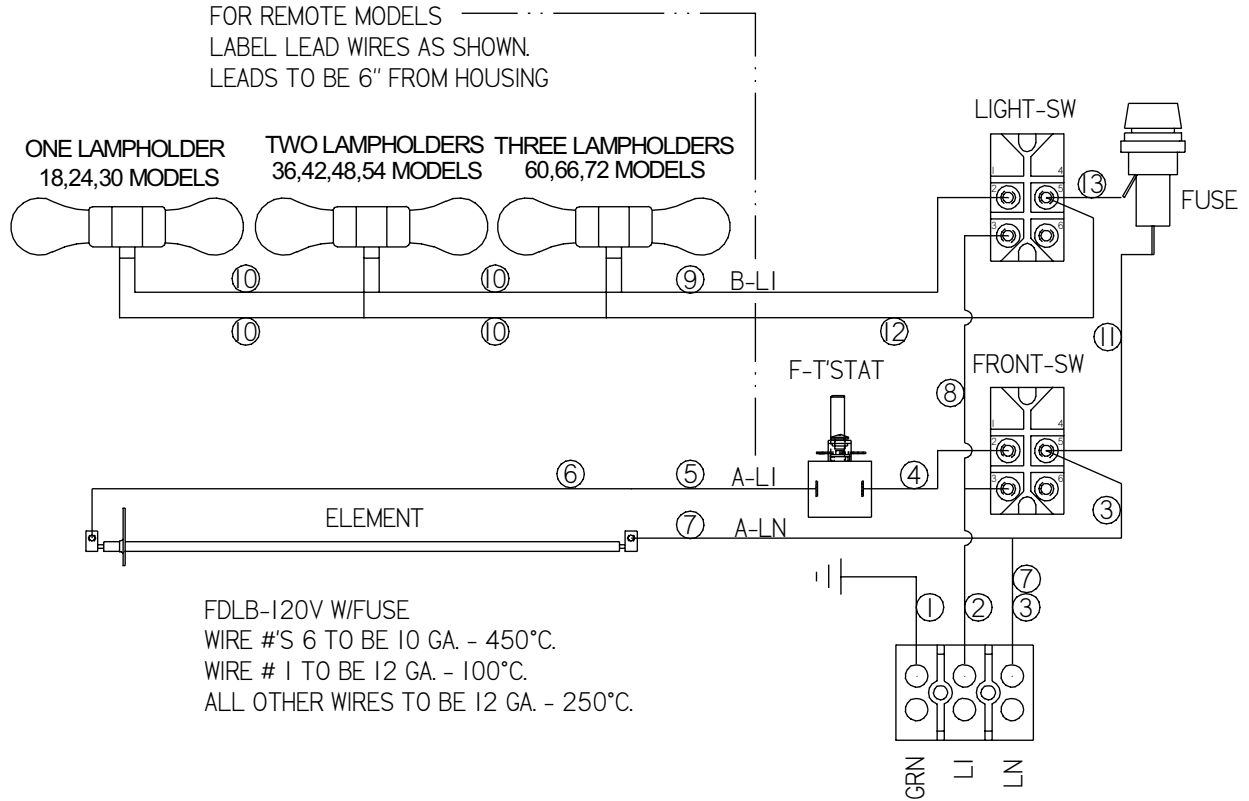

F. FDDB-120V WIRING DIAGRAM

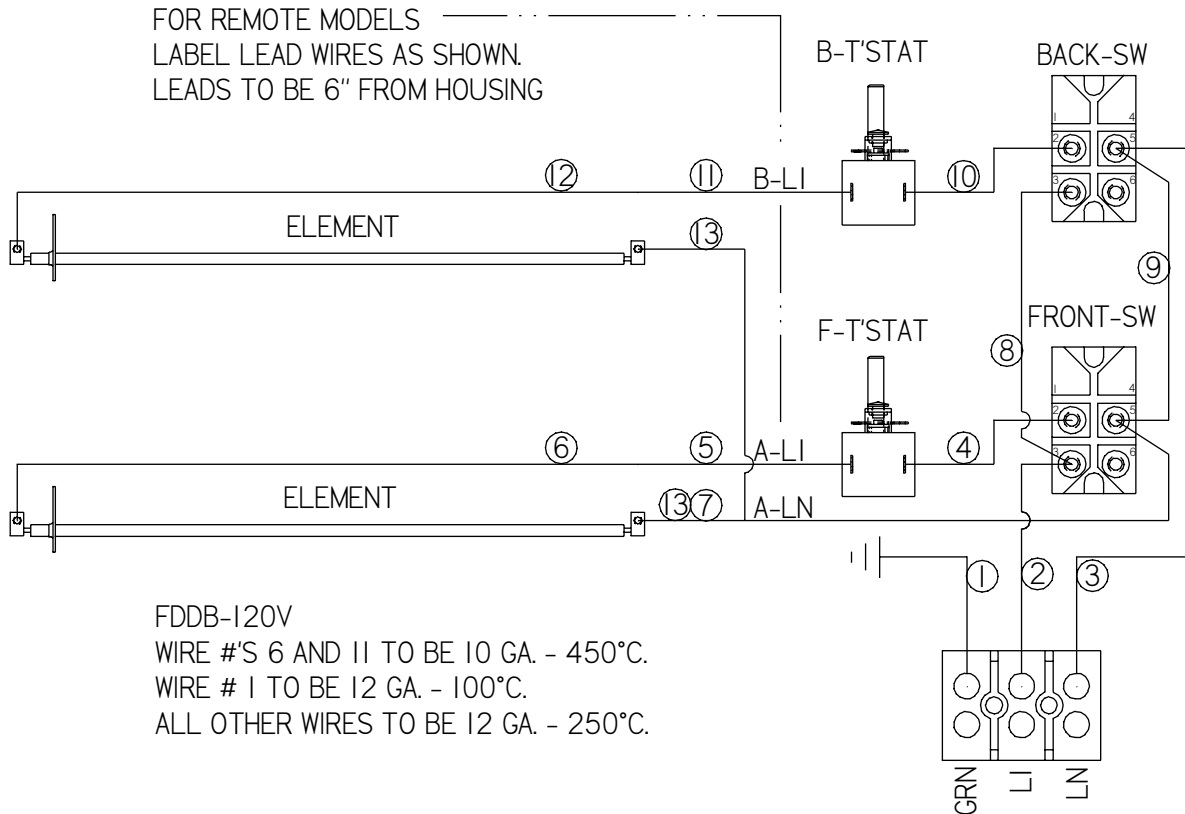

G. Fddb-208/240V WIRING DIAGRAM

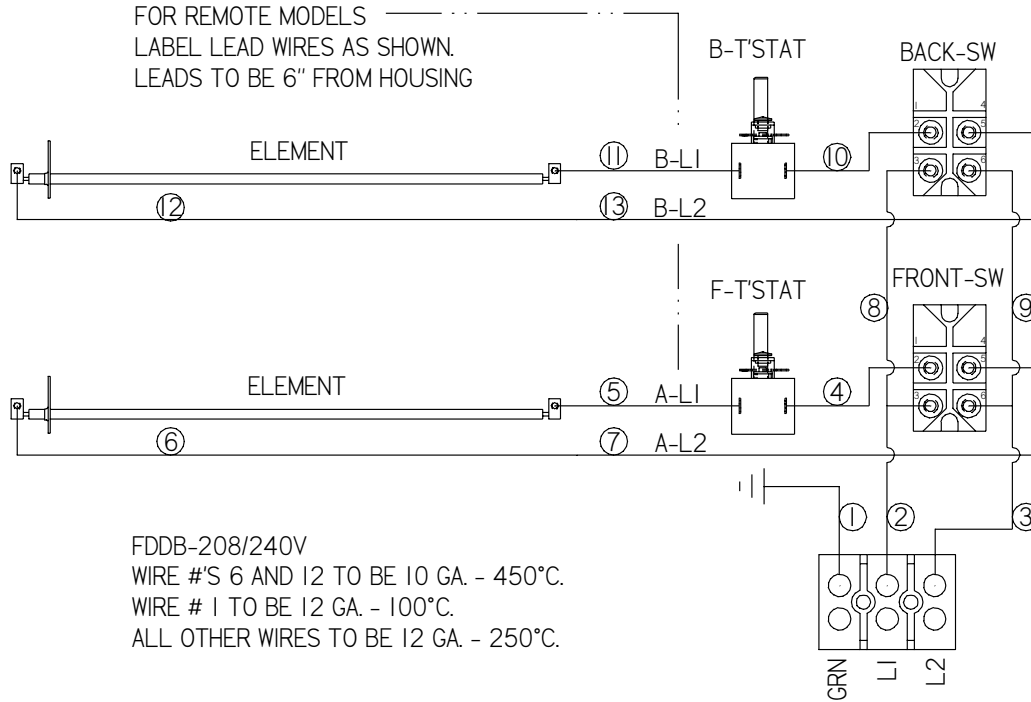

H. FDDLb-120V WIRING DIAGRAM

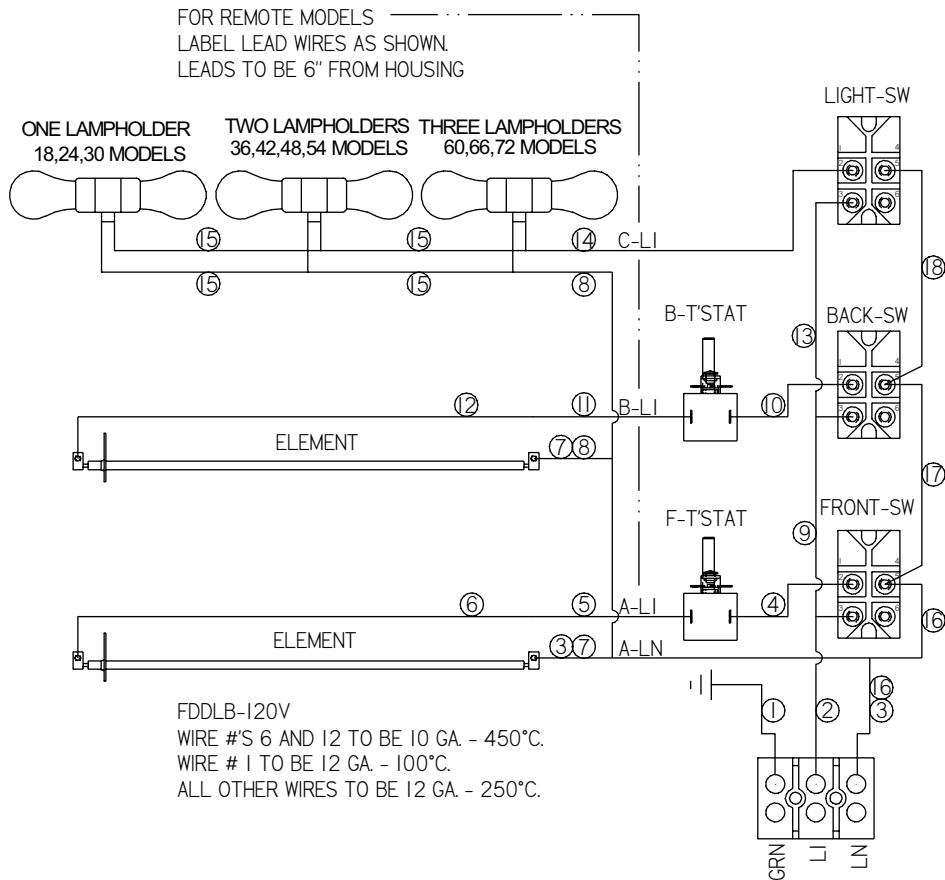

I. FDDL B-208/240V WIRING DIAGRAM

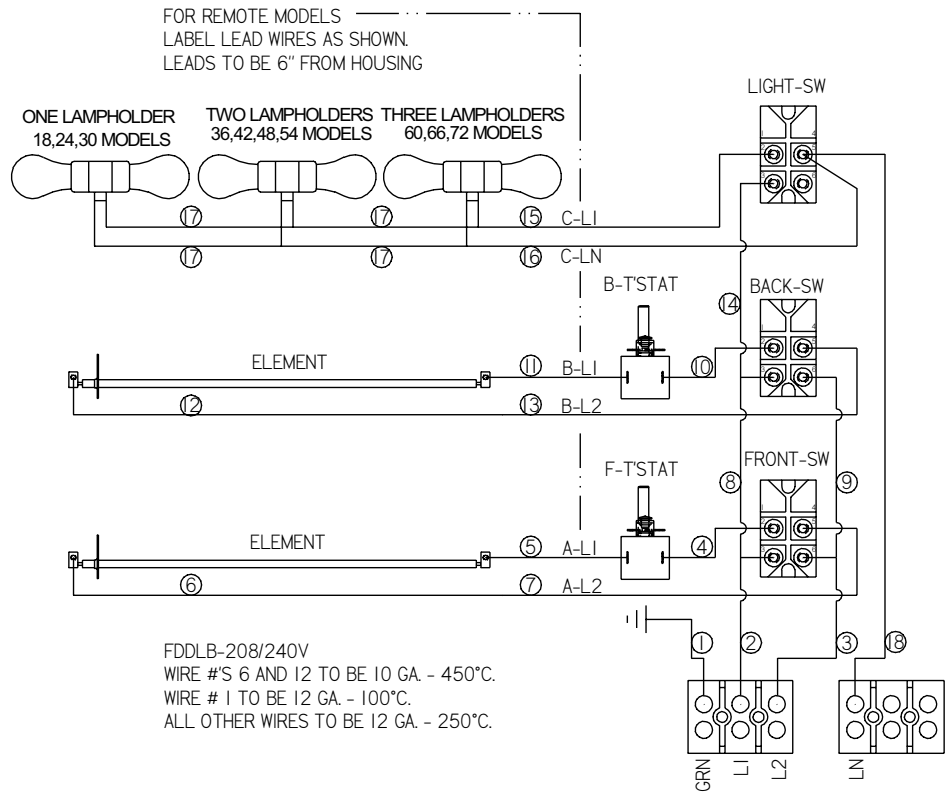

J. FDDL B-208/240V w/FUSE WIRING DIAGRAM

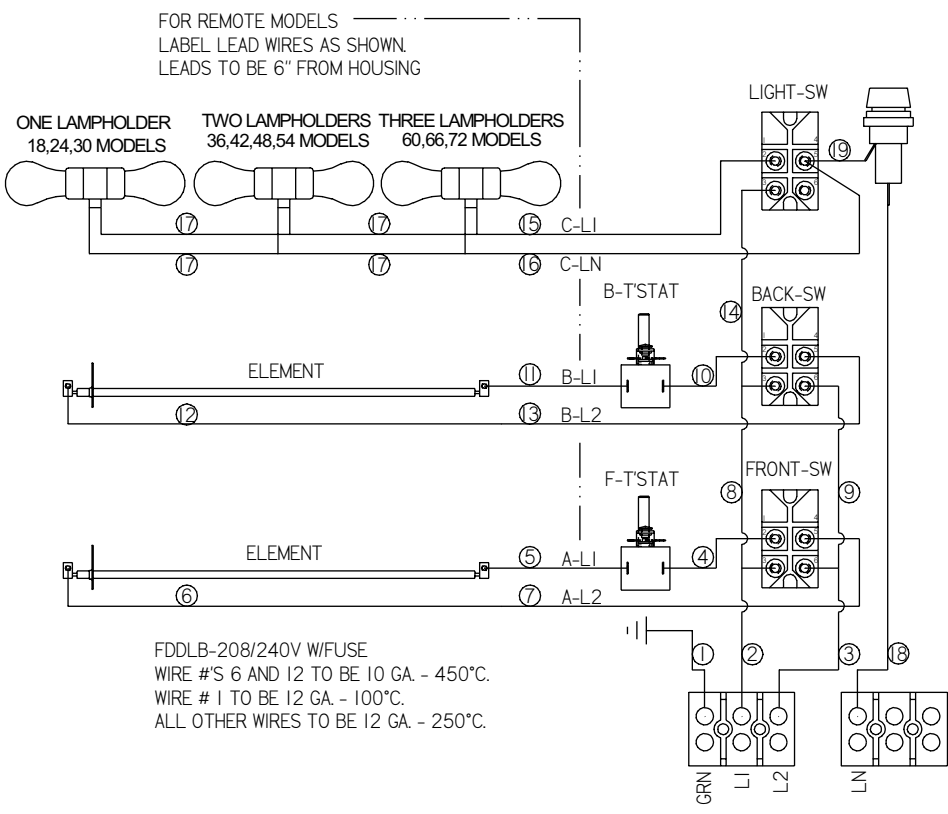

10. PARTS LIST & EXPLODED VIEW

FDB / FDLB / FDDB / FDDLB-18 to 72 EXPLODED VIEW

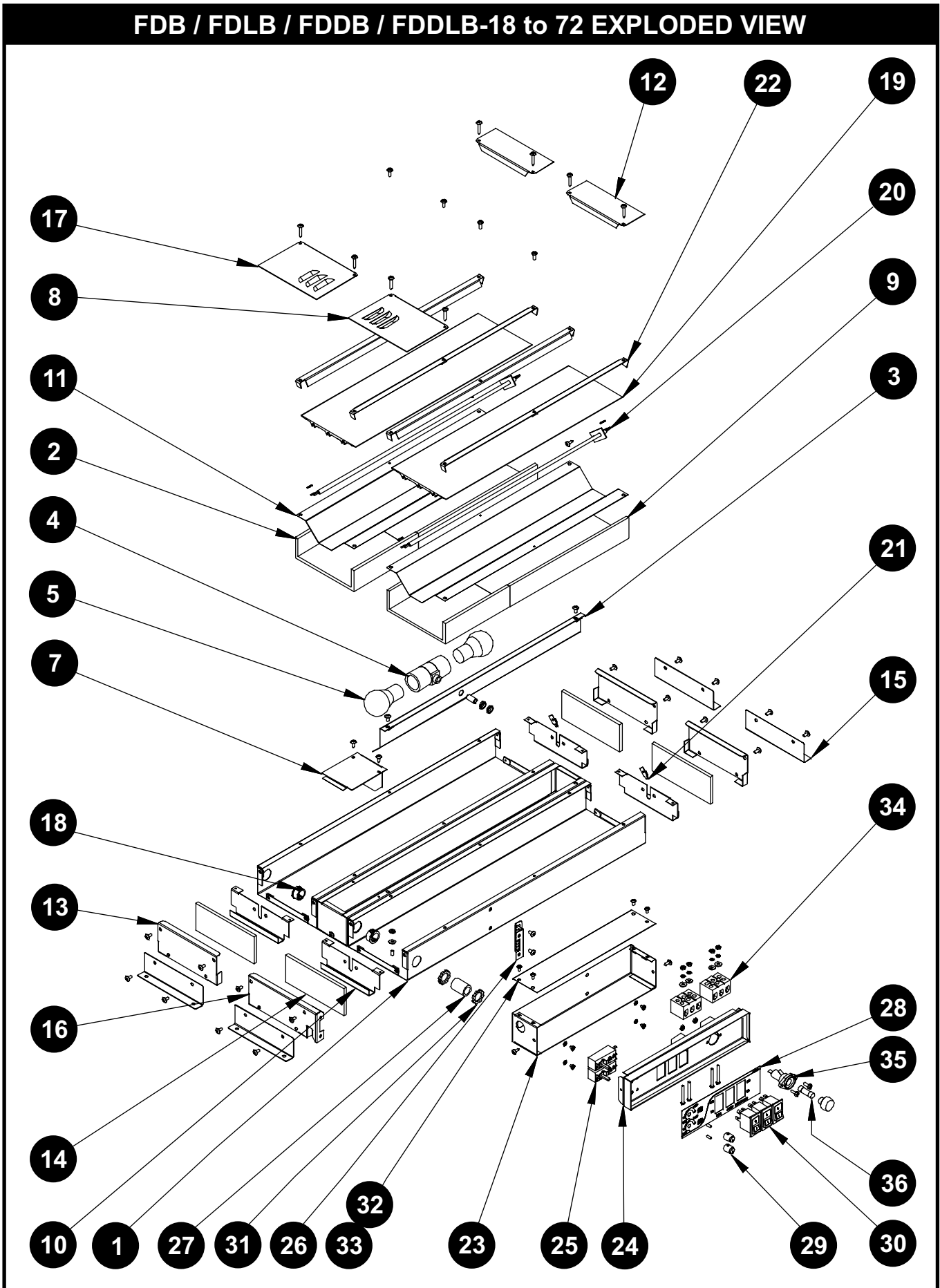

FDB / FDLB / Fddb / FDDLb-18 to 72 PARTS LIST

ITEM	P/N	DESCRIPTION	QUAN	ITEM	P/N	DESCRIPTION	QUAN
1	70476835	HOUSING W/ASS'Y FDB-18	1	11	76806	REFLECTOR FD24	S-1 D-2
1	70476836	HOUSING W/ASS'Y FDB-24	1	11	76807	REFLECTOR FD30	S-1 D-2
1	70476837	HOUSING W/ASS'Y FDB-30	1	11	76808	REFLECTOR FD36	S-1 D-2
1	70476838	HOUSING W/ASS'Y FDB-36	1	11	76809	REFLECTOR FD42	S-1 D-2
1	70476839	HOUSING W/ASS'Y FDB-42	1	11	76810	REFLECTOR FD48	S-1 D-2
1	70476840	HOUSING W/ASS'Y FDB-48	1	11	76811	REFLECTOR FD54	S-1 D-2
1	70476841	HOUSING W/ASS'Y FDB-54	1	11	76812	REFLECTOR FD60	S-1 D-2
1	70476842	HOUSING W/ASS'Y FDB-60	1	11	76813	REFLECTOR FD66	S-1 D-2
1	70476843	HOUSING W/ASS'Y FDB-66	1	11	76814	REFLECTOR FD72	S-1 D-2
1	70476844	HOUSING W/ASS'Y FDB-72	1	12	70400154	COVER, SMALL FD	S-1 D-2
1	70476845	HOUSING W/ASS'Y FDLB-18	1	13	76803	END PLATE FD	S-1 D-3
1	70476846	HOUSING W/ASS'Y FDLB-24	1	14	70402029	INSULATION 1/2 X 6 X 2-1/2 FD18-72	S-2 D-4
1	70476847	HOUSING W/ASS'Y FDLB-30	1	15	76955	BRACKET MOUNTING FD	S-2 D-4
1	70476848	HOUSING W/ASS'Y FDLB-36	1	16	70476803	PLATE, FDB AND C END	1
1	70476849	HOUSING W/ASS'Y FDLB-42	1	17	70400151	COVER LARGE FD LH CTRL	S-0 D-1
1	70476850	HOUSING W/ASS'Y FDLB-48	1	18	89184	BUSHING, .875 HEYCO 2126	S-0 SL-1 D-2
1	70476851	HOUSING W/ASS'Y FDLB-54	1	19	70400155	EXTRUSION, BLACK ANODIZED FD-18	S-1 D-2
1	70476852	HOUSING W/ASS'Y FDLB-60	1	19	70400157	EXTRUSION, BLACK ANODIZED FD-24	S-1 D-2
1	70476853	HOUSING W/ASS'Y FDLB-66	1	19	70400159	EXTRUSION, BLACK ANODIZED FD-30	S-1 D-2
1	70476854	HOUSING W/ASS'Y FDLB-72	1	19	70400161	EXTRUSION, BLACK ANODIZED FD-36	S-1 D-2
1	70476855	HOUSING W/ASS'Y Fddb/FDDLb-18	1	19	70400163	EXTRUSION, BLACK ANODIZED FD-42	S-1 D-2
1	70476856	HOUSING W/ASS'Y Fddb/FDDLb-24	1	19	70400165	EXTRUSION, BLACK ANODIZED FD-48	S-1 D-2
1	70476857	HOUSING W/ASS'Y Fddb/FDDLb-30	1	19	70400167	EXTRUSION, BLACK ANODIZED FD-54	S-1 D-2
1	70476858	HOUSING W/ASS'Y Fddb/FDDLb-36	1	19	70400169	EXTRUSION, BLACK ANODIZED FD-60	S-1 D-2
1	70476859	HOUSING W/ASS'Y Fddb/FDDLb-42	1	19	70400171	EXTRUSION, BLACK ANODIZED FD-66	S-1 D-2
1	70476860	HOUSING W/ASS'Y Fddb/FDDLb-48	1	19	70400173	EXTRUSION, BLACK ANODIZED FD-72	S-1 D-2
1	70476861	HOUSING W/ASS'Y Fddb/FDDLb-54	1	20	75801	ELEMENT, 400W - 120V	S-1 D-2
1	70476862	HOUSING W/ASS'Y Fddb/FDDLb-60	1	20	75833	ELEMENT, 400W - 208V	S-1 D-2
1	70476863	HOUSING W/ASS'Y Fddb/FDDLb-66	1	20	75830	ELEMENT, 400W - 240V	S-1 D-2
1	70476864	HOUSING W/ASS'Y Fddb/FDDLb-72	1	20	75461	ELEMENT, 575W - 120V	S-1 D-2
2	70402028	INSULATION OVRHEAD WRM'R 18-72	2	20	75813	ELEMENT, 575W - 208V	S-1 D-2
3	76211	LIGHT SUPPORT W/A DL-18	1	20	75814	ELEMENT, 575W - 240V	S-1 D-2
3	76212	LIGHT SUPPORT W/A DL-24	1	20	75802	ELEMENT, 760W - 120V	S-1 D-2
3	76213	LIGHT SUPPORT W/A DL-30	1	20	75820	ELEMENT, 760W - 208V	S-1 D-2
3	76214	LIGHT SUPPORT W/A DL-36	1	20	75831	ELEMENT, 760W - 240V	S-1 D-2
3	76215	LIGHT SUPPORT W/A DL-42	1	20	75803	ELEMENT, 920W - 120V	S-1 D-2
3	76216	LIGHT SUPPORT W/A DL-48	1	20	75804	ELEMENT, 920W - 208V	S-1 D-2
3	76217	LIGHT SUPPORT W/A DL-54	1	20	75805	ELEMENT, 920W - 240V	S-1 D-2
3	76218	LIGHT SUPPORT W/A DL-60	1	20	75819	ELEMENT, 1100W - 120V	S-1 D-2
3	76219	LIGHT SUPPORT W/A DL-66	1	20	75821	ELEMENT, 1100W - 208V	S-1 D-2
3	76220	LIGHT SUPPORT W/A DL-72	1	20	75822	ELEMENT, 1100W - 240V	S-1 D-2
4	75917	LAMPHOLDER TWIN 660W/250V	V	20	75806	ELEMENT, 1265W - 120V	S-1 D-2
5	75916	LAMP 40W COATED #40A15 120V	V	20	75807	ELEMENT, 1265W - 208V	S-1 D-2
6	46877	NIPPLE, 1/8-27 X 3/4 PLATED	V	20	75808	ELEMENT, 1265W - 240V	S-1 D-2
7	76159	COVER, END DL RH CONTROL	1	20	75823	ELEMENT, 1425W - 120V	S-1 D-2
8	70400153	COVER, LARGE FD RH CTRL	1	20	75824	ELEMENT, 1425W - 208V	S-1 D-2
9	70400146	INSULATION OVRHEAD WRM'R 18-72	V	20	75825	ELEMENT, 1425W - 240V	S-1 D-2
9	70400147	INSULATION OVRHEAD WRM'R 18-72	V	20	75841	ELEMENT, 1610W - 120V	S-1 D-2
10	70400152	SUPPORT, ELEMENT FD	S-2 D-4	20	75809	ELEMENT, 1610W - 208V	S-1 D-2
11	76805	REFLECTOR FD18	S-1 D-2	20	75810	ELEMENT, 1610W - 240V	S-1 D-2

V=QTY VARIES PER UNIT S=SINGLE UNIT OR FDB/FDLB SL=SINGLE LIGHTED UNIT OR FDLB D=DOUBLE UNIT OR Fddb/FDDLb

FDB / FDLB / Fddb / FDDLb-18 to 72 PARTS LIST (Continued)

ITEM	P/N	DESCRIPTION	QUAN	ITEM	P/N	DESCRIPTION	QUAN
20	75842	ELEMENT, 1800W - 120V	S-1 D-2	28	70406281	LABEL, FDB CONTROL	1
20	75826	ELEMENT, 1800W - 208V	S-1 D-2	28	70407281	LABEL, FDDLb CONTROL	1
20	75827	ELEMENT, 1800W - 240V	S-1 D-2	28	70408281	LABEL, Fddb CONTROL	1
20	75843	ELEMENT, 1980W - 120V	S-1 D-2	28	70409281	LABEL, FDLb CONTROL	1
20	75811	ELEMENT, 1980W - 208V	S-1 D-2	29	89499	KNOB, INDICATOR	S-1 D-2
20	75812	ELEMENT, 1980W - 240V	S-1 D-2	30	70444800	SWITCH, ROCKER ON-OFF	V
21	58004	FASTENER SELF RETAINING J TYPE	S-2 D-4	31	55102	LOCKNUT, 1/2 INCH CONDUIT	2
22	70400433	SUPPORT, WELD ASSY FD-18	S-2 D-4	32	70400007	PLATE, ACCESS	1
22	70400434	SUPPORT, WELD ASSY FD-24	S-2 D-4	33	70401007	PLATE, 12 INCH ACCESS	
22	70400435	SUPPORT, WELD ASSY FD-30	S-2 D-4	34	70444700	BLOCK, TERMINAL, 3-POLE, KULKA	V
22	70400436	SUPPORT, WELD ASSY FD-36	S-2 D-4	35	85602	HOLDER, FUSE	1
22	70400437	SUPPORT, WELD ASSY FD-42	S-2 D-4	36	85601	FUSE, BUS SC3 AMP	1
22	70400438	SUPPORT, WELD ASSY FD-48	S-2 D-4	N/S	89074	STUD, 6-32 X 3/8 NO FLANGE	S-1 D-2
22	70400439	SUPPORT, WELD ASSY FD-54	S-2 D-4	N/S	46876	NUT HEX 1/8 -27 PLATED	V
22	70400440	SUPPORT, WELD ASSY FD-60	S-2 D-4	N/S	88961	NUT, HEX 10-24, GREEN	1
22	70400441	SUPPORT, WELD ASSY FD-66	S-2 D-4	N/S	70400234	SCREW, #8 X 1 AB SMS PHL TRUSS	S-4 D-8
22	70400442	SUPPORT, WELD ASSY FD-72	S-2 D-4	N/S	89042	SCREW 8-32 X 1/2 PH SL SS	V
23	70476314	REMOTE ENCLOSURE, SNGL CNTRL 8"	1	N/S	88889	SCREW #8 X 1/2 AB SMS PHL TRUSS	S-3 SL-5 D-6
23	70476316	REMOTE ENCLOSURE, SNGL CNTRL 12"	1	N/S	88993	SCREW 10-32X3/8 TRS PHL NYLK	V
24	70421275	W/ASS'Y, REMOTE BOX CVR 12" W/FUSE	1	N/S	89071	WASHER, #10 FLAT	V
24	70401275	W/ASS'Y, REMOTE BOX CVR 12" W/FUSE	1	N/S	89059	WASHER #10 EXTERNAL LOCK	S-2 D-4
24	70411275	W/ASS'Y, REMOTE BOX CVR 8" 2 T/B	1	N/S	89056	WASHER #8 INTERNAL LOCK, SS	S-4 D-8
24	70412275	W/ASS'Y, REMOTE BOX CVR 8" 1 T/B	1	N/S	89039	SCREW, 8-32X5/16 PH PAN SS	1
25	70444900	THERMOSTAT, BULB, 518ÿ F	S-1 D-2	N/S	88971	SCREW, 8-32x1-1/2 SL PN HD SS	V
26	70400005	BRACKET, CONTROL BOX	1	N/S	88954	SCREW,8-32X3/16,PH,PH,SS	V
27	70400006	CONDUIT, ALUMINUM	1	N/S	89063	NUT, HEX 8-32	V

V=QTY VARIES PER UNIT S=SINGLE UNIT OR FDB/FDLB SL=SINGLE LIGHTED UNIT OR FDLB D=DOUBLE UNIT OR Fddb/FDDLb N/S=NOT SHOWN

Warranty Procedure

IF YOU NEED WARRANTY SERVICE FOR YOUR APW EQUIPMENT, FOLLOW THESE STEPS:

1. Secure the model and serial number from the data tag of your unit.
2. Non-portable equipment - The service agency will dispatch a technician to your location for repairs.
3. Portable equipment - If you request service at your location, you will be responsible for payment of travel and mileage charges. You can take the unit to the service agency to avoid these charges.
4. For the name of the closest authorized service/parts distributor consult the published list supplied by APW Wyott or call the APW Wyott Service Hot Line, 1-800-733-2203

11. APW WYOTT EQUIPMENT LIMITED WARRANTY

APW Wyott Foodservice Equipment Company warrants its equipment against defects in materials and workmanship, subject to the following conditions:

This warranty applies to the original owner only and is not assignable.

Should any product fail to function in its intended manner under normal use within the limits defined in this warranty, at the option of APW Wyott such product will be repaired or replaced by APW Wyott or its Authorized Service Agency. APW Wyott will only be responsible for charges incurred or service performed by its Authorized Service Agencies. The use of other than APW Wyott Authorized Service Agencies will void this warranty and APW Wyott will not be responsible for such work or any charges associated with same. The closest APW Wyott Authorized Service Agent must be used.

This warranty covers products shipped into the 48 contiguous United States, Hawaii, metropolitan areas of Alaska and Canada. There will be no labor coverage for equipment located on any island not connected by roadway to the mainland.

Warranty coverage on products used outside the 48 contiguous United States, Hawaii, and metropolitan areas of Alaska and Canada may vary. Contact the international APW Wyott distributor, dealer, or service agency for details.

Time Period

One year for parts and one year for labor, effective from the date of purchase by the original owner. The Authorized Service Agency may, at their option, require proof of purchase. Parts replaced under this warranty are warranted for the un-expired portion of the original product warranty only.

Exceptions

- ***Gas/Electric Cookline:** Models GCB, GCRB, GF, GGM, GGT, CHP-H, EF, EG, EHP. Three (3) Year Warranty on all component parts, except switches and thermostats. (2 additional years on parts only. No labor on second or third year.)
- ***Broiler Briquettes, Rock Grates, Cooking Grates, Burner Shields, Fireboxes:** 90 Day Material Only. No Labor.
- ***Heat Strips:** Models FD, FDL, FDD, FDDL. Two (2) Year Warranty on element only. No labor second year.
- ***Glass Windows, Doors, Seals, Rubber Seals, Light Bulbs:** 90 Day Material Only. No Labor.

In all cases, parts covered by extended warranty will be shipped FOB the factory after the first year.

Portable Carry In Products

Equipment weighing over 70 pounds or permanently installed will be serviced on-site as per the terms of this warranty. Equipment weighing 70 pounds or under, and which is not permanently installed, i.e. with cord and plug, is considered portable and is subject to the following warranty handling limitations. If portable equipment fails to operate in its intended manner on the first day of connection, or use, at APW Wyott's option or its Authorized Service Agency, it will be serviced on site or replaced.

From day two through the conclusion of this warranty period, portable units must be taken to or sent prepaid to the APW Wyott Authorized Service Agency for in-warranty repairs. No mileage or travel charges are allowed on portable units after the first day of use. If the customer wants on-site service, they may receive same by paying the travel and mileage charges. Exceptions to this rule: (1) countertop warmers and cookers, which are covered under the Enhanced Warranty Program, and (2) toasters or rollergrills which have in store service.

Exclusions

The following conditions are not covered by warranty:

- *Equipment failure relating to improper installation, improper utility connection or supply and problems due to ventilation.
- *Equipment that has not been properly maintained, calibration of controls, adjustments, damage from improper cleaning and water damage to controls.
- *Equipment that has not been used in an appropriate manner, or has been subject to misuse or misapplication, neglect, abuse, accident, alteration, negligence, damage during transit, delivery or installation, fire, flood, riot or act of god.
- *Equipment that has the model number or serial number removed or altered.

If the equipment has been changed, altered, modified or repaired by other than an Authorized Service Agency during or after the warranty period, then the manufacturer shall not be liable for any damages to any person or to any property, which may result from the use of the equipment thereafter.

This warranty does not cover services performed at overtime or premium labor rates. Should service be required at times which normally involve overtime or premium labor rates, the owner shall be charged for the difference between normal service rates and such premium rates. APW Wyott does not assume any liability for extended delays in replacing or repairing any items beyond its control.

In all cases, the use of other than APW Wyott Authorized OEM Replacement Parts will void this warranty.

This equipment is intended for commercial use only. Warranty is void if equipment is installed in other than commercial application.

Water Quality Requirements

Water supply intended for a unit that has in excess of 3.0 grains of hardness per gallon (GPG) must be treated or softened before being used. Water containing over 3.0 GPG will decrease the efficiency and reduce the operation life of the unit.

Note: Product failure caused by liming or sediment buildup is not covered under warranty.

"THE FOREGOING WARRANTY IS IN LIEU OF ANY AND ALL OTHER WARRANTIES EXPRESSED OR IMPLIED INCLUDING ANY IMPLIED WARRANTY OF MERCHANTABILITY OR FITNESS FOR PARTICULAR PURPOSES AND CONSTITUTES THE ENTIRE LIABILITY OF APW WYOTT. IN NO EVENT DOES THE LIMITED WARRANTY EXTEND BEYOND THE TERMS STATED HEREIN."

9/05



Phone: +1 (214) 421-7366
Fax: +1 (214) 565-0976
Toll Free: +1 (800) 527-2100
Website: www.apwwyott.com
E-mail: info@apwwyott.com

APW WYOTT
729 Third Avenue
Dallas, TX 75226