



**INSTALLATION  
AND  
OPERATING  
INSTRUCTIONS**

**HEATED DISPLAY CABINET**

**MODEL: HDC-4**



**WARNING:** Improper installation, adjustment, alteration, service or maintenance can cause property damage, injury or death. Read the installation, operating and maintenance instructions thoroughly before installing or servicing this equipment.



**IMPORTANT FOR FUTURE REFERENCE**

Please complete this information and retain this manual for the life of the equipment. For Warranty Service and/or Parts, this information is required.

\_\_\_\_\_   
Model Number

\_\_\_\_\_   
Serial Number

\_\_\_\_\_   
Date Purchased

P/N 88090-25 9-05

**APW WYOTT Foodservice Equipment Company**

P.O. Box 1829  
Cheyenne, WY 82003

+1 (307) 634-5801 Phone  
+1 (307) 637-8071 Fax

+1 (800) 752-0863 Toll Free  
[www.apwwyott.com](http://www.apwwyott.com)

## GENERAL INFORMATION

### THIS MANUAL SHOULD BE RETAINED FOR FUTURE REFERENCE



**CAUTION:** These models are designed, built, and sold for commercial use only. Only persons trained and familiar with their proper use should operate them. They are not meant for operation by the general public under any circumstances.



**IMPORTANT:** We strongly recommend having a licensed electrician install this equipment. The electrician should be familiar with all local and national electrical codes.



**WARNING:** Check the data plate on this unit before installation. Connect the unit only to the voltage and frequency listed on the data plate. Connect only to 1 or 3 phase as listed on the data plate.



**WARNING:** Electrical and grounding connections must comply with the applicable portions of the national electrical code and/or other local electrical codes.



**WARNING:** Disconnect device from electrical power supply and place a Tag Out-Lockout on the power plug, indicating that you are working on the circuit.



**WARNING:** Install per the spacing requirements listed in the installation section of this manual. We strongly recommend having a competent professional install the equipment. A licensed electrician should make the electrical connections and connect power to the unit. Local codes should always be used when connecting these units to electrical power. In the absence of local codes, use the latest version of the National Electrical Code.



Maintenance & repair should be handled by a factory authorized agent. Before doing any maintenance or repair, contact APW Wyott Technical Service Department at (800) 752-0863 or (307) 634-5801.

## TABLE OF CONTENTS

General Information .....	2
Description, Installation & Operation .....	3
Electrical Ratings .....	3
Equipment Set-Up .....	3
Installation .....	3
Operation .....	3
Cleaning .....	4
Maintenance .....	4
Parts List w/Exploded Views .....	4
Wiring Diagram .....	6
Warranty .....	7

## GENERAL INFORMATION

### General Installation

1. Always clean equipment thoroughly before first use. (See general cleaning instructions).
2. Check rating label for your model designation and electrical rating.
3. This unit can be used with the legs supplied or by sealing this unit to a counter top.

### General Operation Instructions

1. All foodservice equipment should be operated by trained personnel.
2. Do not allow your customers to come into contact with any surface labeled "CAUTION HOT".
3. Where applicable, never pour cold water into dry heat units.
4. Where applicable, do not cook, warm or hold food directly in bottom of unit. Always use racks and pans.
5. NEVER HOLD FOOD BELOW 140° F.

### **General Cleaning Instructions**

1. Never clean any electrical unit by immersing it in water. Turn unit off and allow it to cool down before surface cleaning.
2. Always clean equipment thoroughly before first use. Clean unit daily. Except where noted on charts: Use warm, soapy water. Mild cleaners and PLASTIC scouring pads may be used to remove baked-on food and water scale on metal units.
3. Unplug electrical units before cleaning or servicing. All service should be performed by an APW Wyott authorized service agency.

### **General Troubleshooting**

Always ask and check:

1. Is the unit connected to a live power source?
2. Check circuit breaker.
3. Is the power switch on and the pilot light glowing?
4. Check the rating label. Are you operating the unit on the proper voltage? If the above checks out and you still have problems, call an APW Wyott authorized service agency.

## **DESCRIPTION, INSTALLATION AND OPERATION**

### **Description**

1. These electrical units are designed for countertop operation. They are intended to keep food warm, not for cooking or reheating.

## **ELECTRICAL RATINGS**

1. MODEL HDC-4 HEATED DISPLAY CABINET -120 Volt, 60 Hz, 1 Phase, 10.5 AMP  
OR
2. 220 Volt, 50 Hz, 1 Phase, 7 AMP

## **EQUIPMENT SET UP**

### **Installation**

1. This unit is shipped as a complete unit and does not require any field assembly except for the supporting legs as if they are going to be used.
2. Install this unit on a counter top close to an outlet with the proper volts for the unit you are installing.
3. This unit can be installed by sealing the unit to a counter top without the legs or by installing the one inch adjustable legs provided for a portable unit.
4. Be sure not to block the louvers located on the sides of the cabinet.

**NOTE:** Clean unit thoroughly before putting this unit into service.

### **Operation**

1. Plug the power cord into a properly rated electrical outlet.
2. Adjust the thermostats to the desired air and water temperature.
3. Allow unit to stabilize before storing product.

**NOTE:** NEVER HOLD FOOD BELOW 140°F.

### **Before First Use and Cleaning**

1. Before first use, clean using a non-corrosive, grease-dissolving commercial cleaner, clean the protective metal oils from all the surface parts. Follow the cleaner manufacturer's directions. Clean all the accessories, rinse and wipe dry the unit and all accessories.

## Cleaning

1. Always allow the unit to cool before cleaning.

## Daily

1. Wash all exterior and interior surfaces at least once daily. Use a cloth with warm water and a mild soap or detergent. A non-abrasive cleaner may be used to remove discoloration's. Always rub in the direction of the polish lines on the stainless steel finishes. Do not use steel wool. Pieces of steel wool will adhere to the stainless steel and cause rusting.

## Maintenance

1. Follow general cleaning instruction.
2. Disconnect electrical power supply.
3. Clean the water pan by removing the units top panel (four screws), see illustration on page 6, then loosen the air channel cover (six screws). Remove the water pan cover (four screws) by sliding it out from underneath the air channel cover then lift it straight up, the float switch and thermostat bulb are attached to this cover and are easily damaged so use caution. Remove any mineral buildup from the thermostat bulb and float switch. Remove mineral buildup from water pan. Replace the water pan cover, tighten all screws on the water pan cover and the air channel cover. Replace the unit top and replace the screws.

## REPLACEMENT PARTS LIST - HDC-4

ITEM	P/N	DESCRIPTION	ITEM	P/N	DESCRIPTION
1	217215-51	Display Motor, 120 V	28	81300-00	Screw, #8-32 X 3/8" Type T
	217215-52	Display Motor 220V	29	81139-00	Screw, #6-32 X 1-3/4" Pan Head
2	217215-05	Pizza Rack	30	81101-00	Screw, #6-32 X 3/4" Truss Head
	217215-46	Pretzel Rack	31	81073-00	Screw, #6-32 X 1/8" Pan Head
	217215-47	3-Shelf Slant Rack	32	29710-00	Tape, Double Sided 1/4" Wide
	217217-48	4-Shelf Food Rack	33	23283-10	Water Fill
	983620-20	5-Shelf Food Rack	34	23283-00	Door Assemble W/O Strike
3	217215-38	Door Bushing	35	21263-00	Grommet
4	217215-37	Glass Panel	36	15325-00	Cordset, 16/3
5	217215-36	Cabinet Top	37	15206-00	Indicator Light, White-120 V
6	217215-34	Door Strike		15208-30	Indicator Light, White-220V
7	217215-33	Hinge Bracket	38	15205-00	Indicator Light, Red - 120 V
8	217215-32	Rear Corner Cover		15208-00	Indicator Light, Red - 220V
9	217215-31	Front Corner Cover	39	15058-00	Light Bulb, 40 W - 120 V
10	217215-29	Heater Retainer, Water Pan		15058-75	Light Bulb, 40 W - 220 V
11	217215-28	Air Channel Top	40	15056-00	Lamp Socket
12	217215-22	Air Channel Weldment	41	14030-20	Heater, Water - 120 V
13	217215-18	Water Pan Cover Weldment		14030-22	Heater, Water - 220V
14	217215-10	Water Pan Weldment	42	14030-00	Heater, Air - 120 V
15	89804-00	Clamp, 1/4" Dia.		14030-02	Heater, Air - 220V
16	89674-00	Bushing, Strain Relief	43	13278-00	Switch, Door
17	87177-00	Magnetic Catch	44	13277-00	Thermostat
18	87055-00	Knob, Thermostat	45	13149-00	Switch, Float
19	86621-00	Leg, 1" Adjustable	46	13132-00	Relay - 120 V
20	88090-00	Decal, Control Panel		13133-00	Relay - 220V
21	84171-00	Nut, #10-32 Hex KEPS	47	13056-10	Switch, Power
22	84095-00	Nut, #8-32 Acorn	48	12168-00	Blower, 75 CFM - 120 V
23	84083-00	Nut, #8-32 Hex KEPS		217215-71	Blower, 75 CFM - 220 V
24	84001-00	Nut, #6-32 Hex KEPS	49	11068-00	Terminal Block
25	81759-00	Screw, #10-32 X 1/2" Truss Head	50	10362-00	Tape, Silicone Seal 1/2" Wide
26	81537-00	Screw, #8-32 X 1/2" Flat Head	51	10009-00	Sleeve, Fiberglass
27	81349-00	Screw, #8-32 X 3/8" truss Head			

# EXPLODED VIEWS - HDC-4

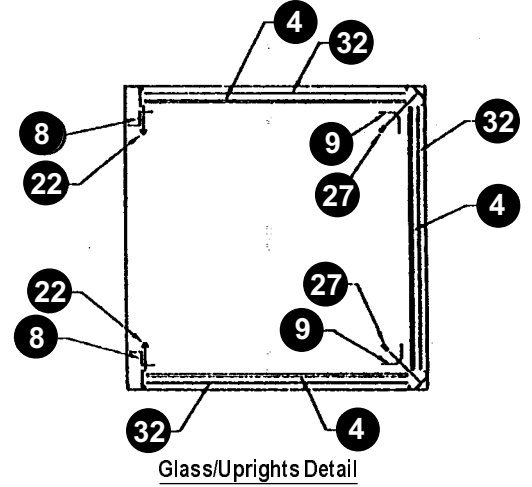
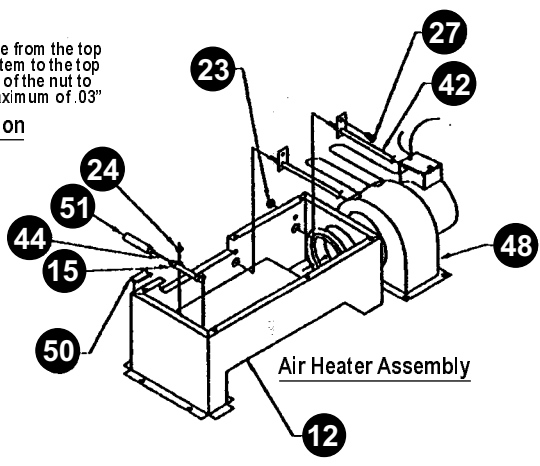
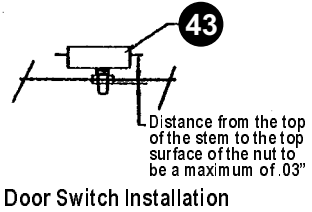
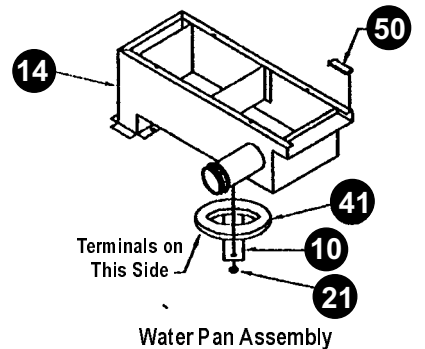
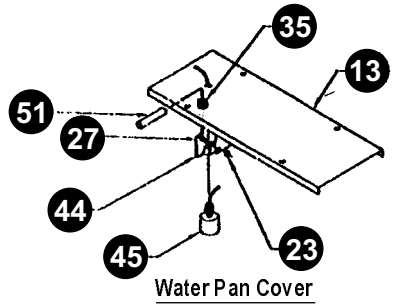
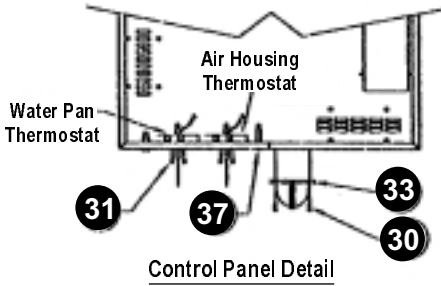
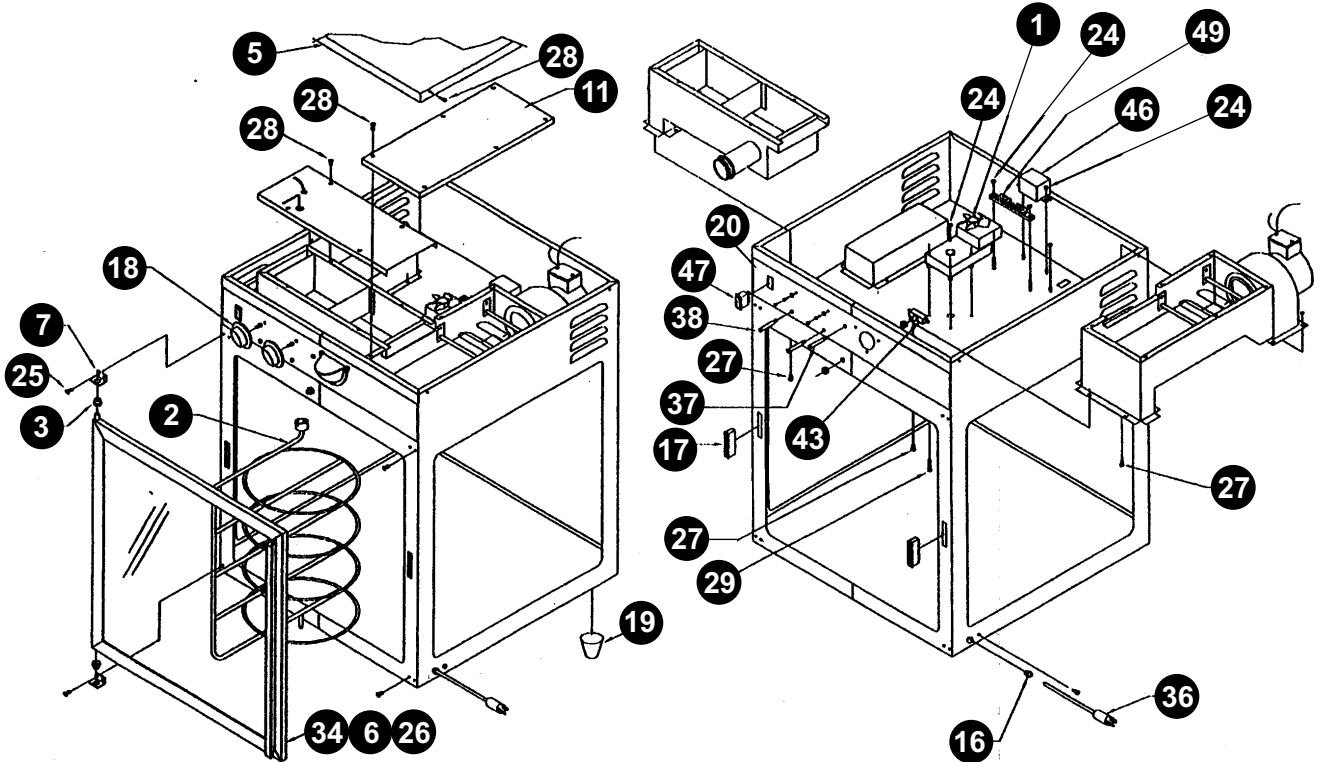

# WIRING DIAGRAM - HDC-4

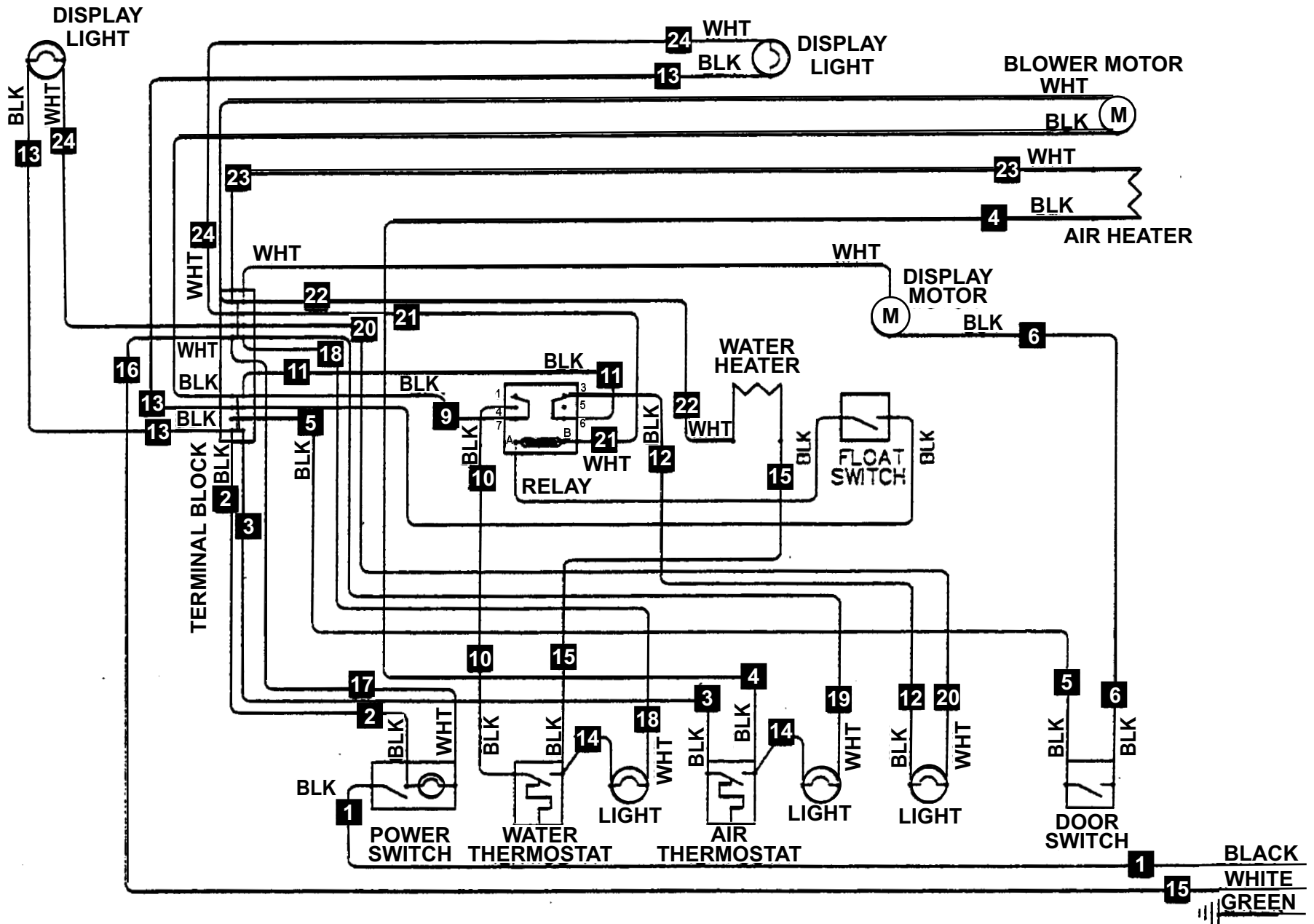

## APW WYOTT EQUIPMENT LIMITED WARRANTY

APW Wyott Foodservice Equipment Company warrants its equipment against defects in materials and workmanship, subject to the following conditions:

This warranty applies to the original owner only and is not assignable.

Should any product fail to function in its intended manner under normal use within the limits defined in this warranty, at the option of APW Wyott such product will be repaired or replaced by APW Wyott or its Authorized Service Agency. APW Wyott will only be responsible for charges incurred or service performed by its Authorized Service Agencies. The use of other than APW Wyott Authorized Service Agencies will void this warranty and APW Wyott will not be responsible for such work or any charges associated with same. The closest APW Wyott Authorized Service Agent must be used.

This warranty covers products shipped into the 48 contiguous United States, Hawaii, metropolitan areas of Alaska and Canada. There will be no labor coverage for equipment located on any island not connected by roadway to the mainland.

Warranty coverage on products used outside the 48 contiguous United States, Hawaii, and metropolitan areas of Alaska and Canada may vary. Contact the international APW Wyott distributor, dealer, or service agency for details.

### Time Period

One year for parts and one year for labor, effective from the date of purchase by the original owner. The Authorized Service Agency may, at their option, require proof of purchase. Parts replaced under this warranty are warranted for the un-expired portion of the original product warranty only.

### Exceptions

- \***Gas/Electric Cookline:** Models GCB, GCRB, GF, GGM, GGT, CHP-H, EF, EG, EHP. Three (3) Year Warranty on all component parts, except switches and thermostats. (2 additional years on parts only. No labor on second or third year.)
- \***Broiler Briquettes, Rock Grates, Cooking Grates, Burner Shields, Fireboxes:** 90 Day Material Only. No Labor.
- \***Heat Strips:** Models FD, FDL, FDD, FDDL. Two (2) Year Warranty on element only. No labor second year.
- \***Glass Windows, Doors, Seals, Rubber Seals, Light Bulbs:** 90 Day Material Only. No Labor.

In all cases, parts covered by extended warranty will be shipped FOB the factory after the first year.

### Portable Carry In Products

Equipment weighing over 70 pounds or permanently installed will be serviced on-site as per the terms of this warranty. Equipment weighing 70 pounds or under, and which is not permanently installed, i.e. with cord and plug, is considered portable and is subject to the following warranty handling limitations. If portable equipment fails to operate in its intended manner on the first day of connection, or use, at APW Wyott's option or its Authorized Service Agency, it will be serviced on site or replaced.

From day two through the conclusion of this warranty period, portable units must be taken to or sent prepaid to the APW Wyott Authorized Service Agency for in-warranty repairs. No mileage or travel charges are allowed on portable units after the first day of use. If the customer wants on-site service, they may receive same by paying the travel and mileage charges. Exceptions to this rule: (1) countertop warmers and cookers, which are covered under the Enhanced Warranty Program, and (2) toasters or rollergrills which have in store service.

### Exclusions

The following conditions are not covered by warranty:

- \*Equipment failure relating to improper installation, improper utility connection or supply and problems due to ventilation.
- \*Equipment that has not been properly maintained, calibration of controls, adjustments, damage from improper cleaning and water damage to controls.
- \*Equipment that has not been used in an appropriate manner, or has been subject to misuse or misapplication, neglect, abuse, accident, alteration, negligence, damage during transit, delivery or installation, fire, flood, riot or act of god.
- \*Equipment that has the model number or serial number removed or altered.

If the equipment has been changed, altered, modified or repaired by other than an Authorized Service Agency during or after the warranty period, then the manufacturer shall not be liable for any damages to any person or to any property, which may result from the use of the equipment thereafter.

This warranty does not cover services performed at overtime or premium labor rates. Should service be required at times which normally involve overtime or premium labor rates, the owner shall be charged for the difference between normal service rates and such premium rates. APW Wyott does not assume any liability for extended delays in replacing or repairing any items beyond its control.

In all cases, the use of other than APW Wyott Authorized OEM Replacement Parts will void this warranty.

This equipment is intended for commercial use only. Warranty is void if equipment is installed in other than commercial application.

### Water Quality Requirements

Water supply intended for a unit that has in excess of 3.0 grains of hardness per gallon (GPG) must be treated or softened before being used. Water containing over 3.0 GPG will decrease the efficiency and reduce the operation life of the unit.

**Note: Product failure caused by liming or sediment buildup is not covered under warranty.**

**“THE FOREGOING WARRANTY IS IN LIEU OF ANY AND ALL OTHER WARRANTIES EXPRESSED OR IMPLIED INCLUDING ANY IMPLIED WARRANTY OF MERCHANTABILITY OR FITNESS FOR PARTICULAR PURPOSES AND CONSTITUTES THE ENTIRE LIABILITY OF APW WYOTT. IN NO EVENT DOES THE LIMITED WARRANTY EXTEND BEYOND THE TERMS STATED HEREIN.”**

9/05



**24 Hour Toll Free**



**Service Hot Line:  
1-800-733-2203**

---

**APW WYOTT Foodservice Equipment Company**

P.O. Box 1829  
Cheyenne, WY 82003

+1 (307) 634-5801 Phone  
+1 (307) 637-8071 Fax

+1 (800) 752-0863 Toll Free  
[www.apwwyott.com](http://www.apwwyott.com)