



729 Third Avenue
Dallas, TX 75226

M-95-3

Wendy's Conveyor Toasters

Phone: (214) 421-7366
Fax: (214) 565-0976
Toll Free: (800) 527-2100
Website: www.apwwyott.com
E-mail: info@apwwyott.com

REPLACEMENT PARTS CATALOG & WIRING DIAGRAM

Model	Part Number	Voltage	Hertz
M-95-3	M953CCWD	208V	60Hz
M-95-3	M953ECWD	240V	60Hz
M-95-3	M953FCWD	240V	50Hz





729 Third Avenue
Dallas, TX 75226

M-95-3

Wendy's Conveyor Toasters

Phone: (214) 421-7366
 Fax: (214) 565-0976
 Toll Free: (800) 527-2100
 Website: www.apwwyott.com
 E-mail: info@apwwyott.com

Item	P/N	Description	Item	P/N	Description
1	84180	M95-3 Base Assembly	33	84133	Right Conveyor Side
2	84115	Left Inside Panel	34	84135	Left Conveyor Side
3	84118	Right Inside Panel	35	89000	Bushing Bolt
4	84192	M95-3 Back Brace	36	85228	Bushing
5	84102	Front Cover	37	89165	Knob Back Cover
6	84104	Front Cover Label	38	84536	Lower Conveyor Rod
7	84149	Left Side Panel	39	84520	Upper Conveyor Rod
8	84146	Right Side Panel	40	84530	Conveyor Chain
9	84188	M95-3 Grill Plate	41	84525	Conveyor Divider
10	83065	Left Hanger Bracket	42	84523	Rod Chain Adjustment
11	83061	Right Hanger Bracket	43	85228	Knob, Hanger
12	89408	Motor Switch	44	84548	RH Adjuster Rod
13	56530	Indicator Lamp	45	84549	LH Adjuster Rod
14	60352	Knob For Thermostat	46	84577	RH Bracket
15	89406	Main Power Switch	47	84576	LH Bracket
16	89145	Terminal Block	48	87145	Sprocket
17	56527	Thermostat	49	88702	Thumbscrew
18	85178	2.0 RPM Drive Motor 115V	50	88962	Spring Disc
	85195	2.0 RPM Drive Motor 208-230V, 60Hz	51	84591	Ring Retainer
	85205	2.0 RPM Drive Motor 208-230V, 50Hz	52	85136	Chain Master Link
19	85209	Fan For Drive Motor	53	84139	Heat Transfer Plate
20	85280	Cooling Fan 115V,uses Cord 85285	54	84198	Heating Element 115V
	85281	Cooling Fan 208-230V		84199	Heating Element 208V
21	85282	Fan Guard		84197	Heating Element 220-240V
22	89111	Strain Relief	55	84168	Heating Element Clamp
23	55310	Power Cord 115V Nema 5-15p	56	84167	Heating Element Insulation
	85640	Power Cord 208-230V, Nema 6-15p	57	84141	Heating Element Cover
24	84151	Drive Motor Mount Bracket	58	89120	Thermostat Bulb Clamp
25	84155	Side Support Angle	Not Shown		
26	84187	M95-3 Back Panel	83753		Wire Set
27	84161	Control Panel	89029		Screw For Back Panel
28	87321	Leg (ea.)	88961		Green Ground Nut
29	84178	M95-3 Cross Rod	88993		10-32 X 3/8 Screw
30	<i>Number Below In () Is Matching Conv. Gear Size</i>		88994		10-32 X 3/16 SS Set Screw
	85042	Drive Gear 13t (19)	89031		10-32 X 5/16 Phi SS Screw
	85037	Drive Gear 16t (16)	89054		6-32 Keps Nut
	85183	Drive Gear 17t (15)	89061		10-24 Hex Nut
	85032	Drive Gear 19t (13)	89071		10 Flat Washer
	85047	Drive Gear 21t (11)	89076		1/4 Int Star Washer
31	<i>Number Below In () Is Matching Drive Gear Size</i>		89163		1/4-20 SS Jam Nut
	85046	Conveyor Gear 11t (21)	84165		Control Panel Label
	85033	Conveyor Gear 13t (19)	88923		8-32 X 1 Screw
	85030	Conveyor Gear 15t (17)	89063		8-32 Hex Nut
	85038	Conveyor Gear 16t (16)	89140		Cable Tie
	85043	Conveyor Gear 19t (13)	88894		1/4-20 X 7/8 Press Stud
32	85115	Bushing Drive Teflon			

M-95-3 CONVEYOR TOASTER (Exploded View)

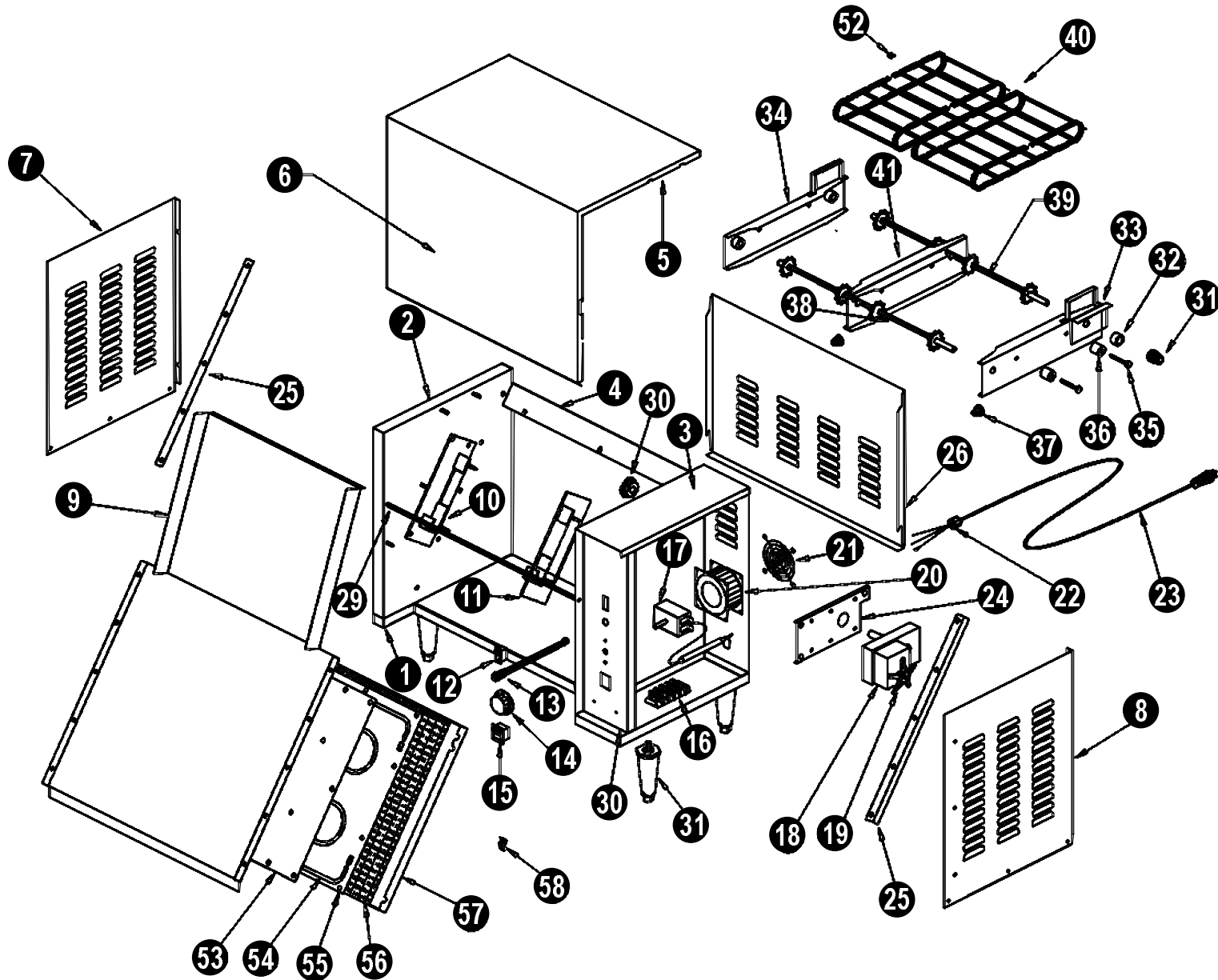

M-95-3 DRY WIRING DIAGRAM

