



**INSTALLATION  
AND  
OPERATING  
INSTRUCTIONS**



**COUNTERTOP  
FULL SIZE 12 x 20 WARMER**

**Model: W-3V (22 Qt. Capacity)**



Phone: +1 (214) 421-7366  
Fax: +1 (214) 565-0976  
Toll Free: +1 (800) 527-2100  
Website: [www.apwwyott.com](http://www.apwwyott.com)  
E-mail: [info@apwwyott.com](mailto:info@apwwyott.com)

P/N 67225 5/06

**APW WYOTT**  
729 Third Avenue  
Dallas, TX 75226

## TABLE OF CONTENTS

<b>Owner's Information</b>	2	Installation, Elec	3
General Installation	2	Operations, Cleaning	3
General Operating Instructions	2	<b>Service Information</b>	3-4
General Cleaning Instructions	2	<b>Wiring Diagram</b>	4
<b>General Troubleshooting</b>	2	<b>Parts List w/Exploded View</b>	5
<b>Specifications</b>	3	<b>Warranty</b>	7

## OWNER'S INFORMATION

### General Installation

1. Always clean equipment thoroughly before first use. (See general cleaning instructions.)
2. Check rating label for your model designation & electrical rating.
3. Locate equipment on level counter and plug into a grounded outlet so that the plug is accessible. (See individual description for electrical loads.) On units bearing the CE marking the appliance must be connected by an earthing cable to all other units in the complete installation and hence to an independent earth connection.

### General Operating Instructions

1. All foodservice equipment should be operated by trained personnel.
2. Do not allow your customers to come in contact with any surface labeled "CAUTION HOT."
3. Where applicable, do not cook, warm or hold food directly in liner pans (well pans). Always use steam table pans/insets, etc.
4. Never hold food below 150°F (66°C)

### General Cleaning Instructions

1. NEVER clean any electrical unit by immersing it in water. Unplug unit before surface cleaning. **NEVER POUR COLD WATER INTO DRY HEATED UNITS.**
2. Always clean equipment thoroughly before first use. Clean unit daily. Except where noted on charts: Use warm, soapy water. Mild cleansers & PLASTIC scouring pads may be used to remove baked-on food & water scale.
3. Unplug all units before cleaning or servicing. All service should be performed by an APW authorized service agency.
4. Do not use chlorides or chloride-based products in this unit. Always clean equipment before first use. Clean unit daily. Use warm, soapy water. Rinse thoroughly to remove all residue. Chlorides, chloride-based products and improper cleaning may cause corrosion and pitting. **FAILURE TO COMPLY WITH THESE INSTRUCTIONS MAY VOID UNIT WARRANTY.**

## GENERAL TROUBLESHOOTING

### Always ask & check:

1. Is the unit plugged in?
2. Check circuit breaker.
3. Is power switch on & pilot light glowing?
4. Check rating label. Are you operating unit on proper voltage?

If the supply cord is damaged, it should only be replaced by an identical supply cord.  
If the above checks out, and you still have problems, call an APW authorized service agency.

# SPECIFICATIONS

## Installation:

Follow General Instructions on previous page.

W-3V (22qt.)..... 120 volt outlet - 10 amp load or 230 volt - 4.8 amp.

## Operations:

Follow General Operating Instructions on previous page.

1. Add hot water (120° - 140°) to well pan: W-3V, use 4 quarts (1 gallon) (4 liter).
2. Turn infinite control to "HI" position and preheat for approximately 10 minutes.
2. Place covered inset with *preheated* food product into well.
3. Re-adjust control to 2 - 4 setting depending on the amount and/or thickness of product.
4. Keep inset/steamtable pan(s) covered to maintain ideal serving temperature.

## Cleaning:

Daily Cleaning

1. Refrigerate remaining product.
2. Follow General Cleaning Instructions on previous page.

# SERVICE INFORMATION

**IF A SHORTAGE OR A PROBLEM CALL - in the USA 1-888-279-7493**

PLEASE FOLLOW THESE INSTRUCTIONS:

- A. ON ALL CALLS YOU WILL NEED TO GIVE THE FOLLOWING INFORMATION.
  1. Name and title of person calling
  2. Phone number of person calling
  3. Business name
  4. Street address
  5. City, State, Zip
  6. Model Number (from serial plate)
  7. Serial Number (from serial plate)
  8. Date purchased (if serial number indicates date of manufacture is over 13 months old you will be asked to supply proof of purchase)
  9. Purchased from
- B. FOR SHORTAGE - SUPPLY THE ABOVE INFORMATION AND FULLY EXPLAIN WHAT IS MISSING. It will be sent immediately - prepaid via UPS or equivalent. (Next Day Air or Priority shipments available at customer's expense)
- C. FOR EQUIPMENT PROBLEM - IF WITHIN ONE YEAR FROM DATE OF PURCHASE THIS UNIT FAILS TO FUNCTION YOU ARE ENTITLED TO - YOUR CHOICE I - 2 or 3.
  1. **APW Wyott will replace the unit.**

When calling the factory, besides the above information you will need Electrical Characteristics, voltage and phase; describe the problems the best you can. The factory will require a \*Visa or Master Card number and expiration date of same to assure return and/or validity of condition. Upon validation of credit card information, factory will strive to ship a replacement unit the same day if call is received before 3:00 p.m. Central Time or the next day if later. The replacement unit will be shipped prepaid regular UPS or equivalent. If requested Next Day Air or Priority, shipment will be made at customers expense. Upon receipt it is the customers responsibility to unpack the new unit taking care to preserve the packaging. Repack the unit being

replaced in the same container using caution to pack properly and return this unit to the factory following the instructions supplied. Factory will supply return label and UPS call tag, both must be used. If original unit is returned within 30 days and is as represented the credit card validation will be cancelled.

**\*IMPORTANT** - If factory does not receive the unit to be returned within 30 days, the unit will be billed to the credit card number supplied. If the returned unit is not as represented - i.e. out of warranty, customer abuse, then it will be billed to the credit card number supplied. In these cases the person calling in the problem will be contacted and if applicable the returned unit if charged for will be returned to the original owner if requested.

2. You may take this unit to the APW Wyott Authorized Service Distributor. List of same is included with each product. If the problem is covered under warranty the unit will be repaired at no cost to you. If the Authorized Agency cannot repair same within a reasonable time while you wait, it will be returned to you prepaid, via UPS.
3. You can request the Authorized Service Distributor to service the equipment on site. If problem is covered under the warranty the parts and labor will be billed to the factory, the mileage and travel time will be responsibility of the owner.

**THIS REPLACEMENT WARRANTY IS ONLY AVAILABLE ON SELECTED PRODUCTS SHIPPED WITHIN THE CONTINENTAL USA, ALASKA, HAWAII AND CANADA. AS WITH MOST WARRANTIES - WARRANTY IS ONLY VALID TO THE ORIGINAL END-USER/OWNER.**

INSTRUCTIONS AND PROCEDURES MUST BE FOLLOWED OR THE WARRANTY IS VOID.

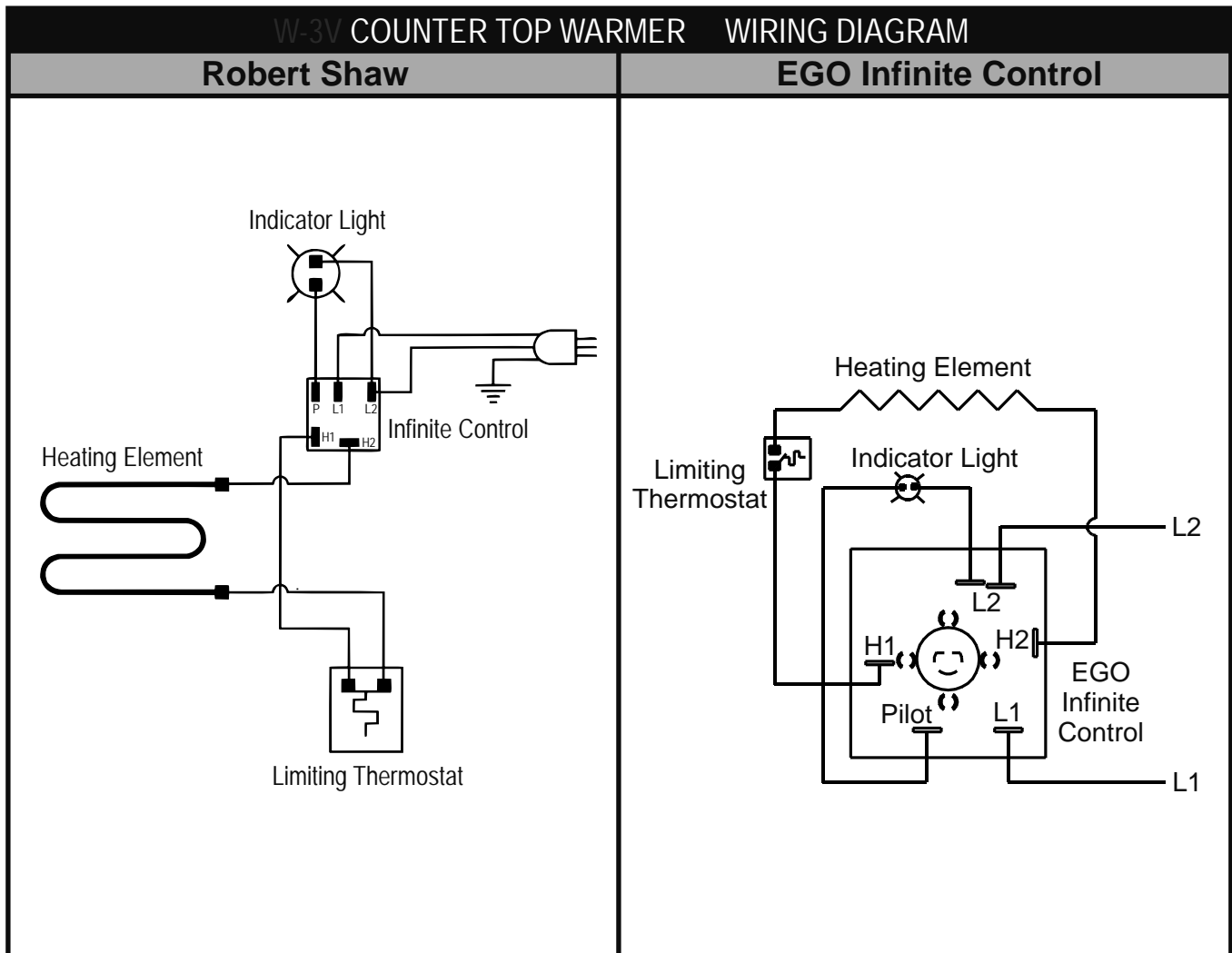

W-3V COUNTER TOP WARMER PARTS LIST w/EXPLODED VIEW

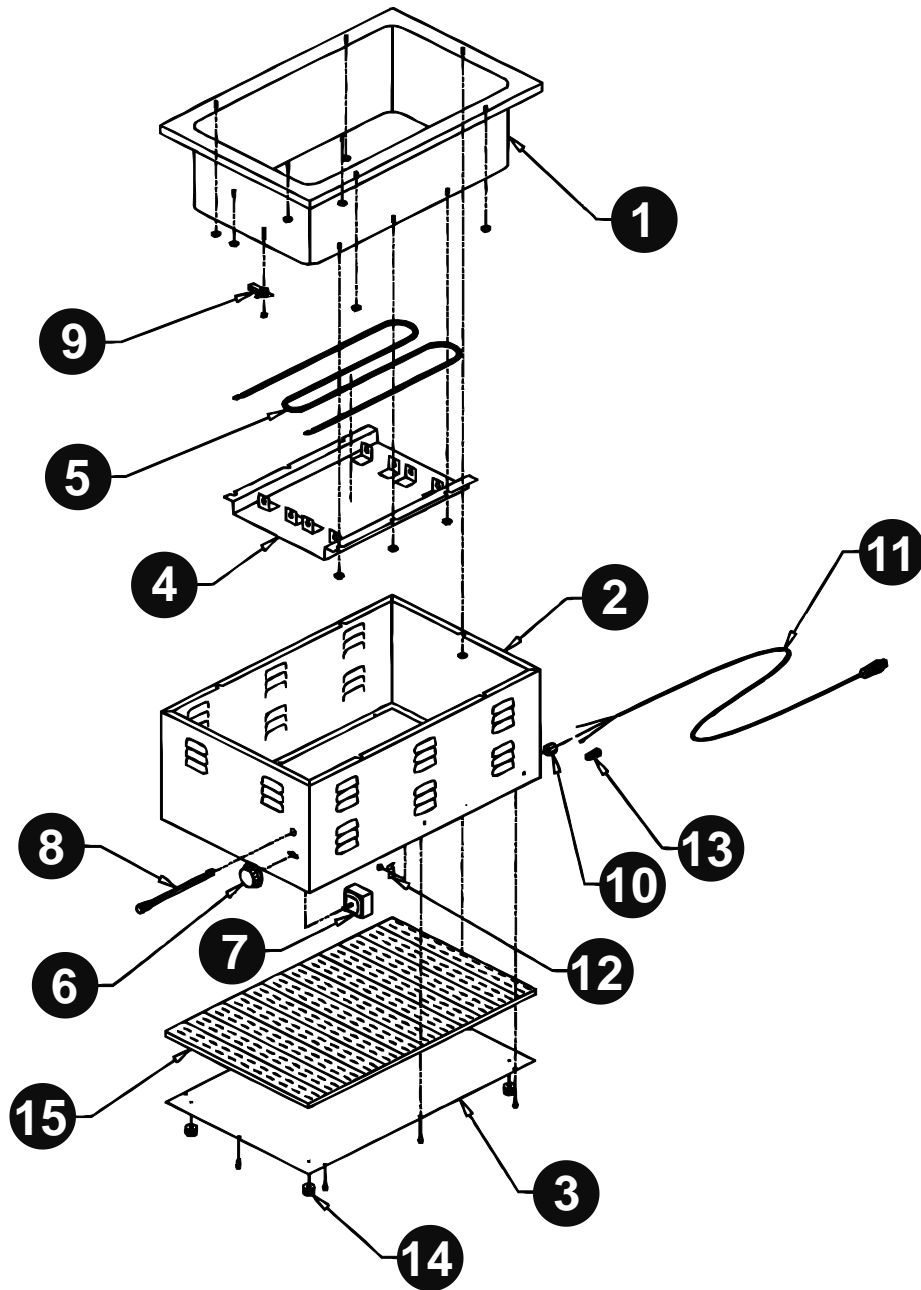

ITEM	P/N	DESCRIPTION	ITEM	P/N	DESCRIPTION
1	54815	Pan Assembly	11	89112	Strain Relief Bushing CE
2	54813	Wrapper Assembly		55947	Power Cord 120V US
3	54816	Bottom Cover		83204	Power Cord 230V Cont. Europe CE
4	56506	Reflector Pan	12	89120	Jiffy Clip
5	55446	Element 120V-1200W	13	89475	Set Screw Wire Nut
	55440	Element 240V-1200W	14	55768	Rubber Foot Assembly
6	55825	Knob, Infinite Control US	15	54817	Insulation
	55826	Knob Infinite Control CE	N/S	89054	6-32 KEPS Nut
7	55564-EGO	Infinite Control 120V	N/S	89073	#8 X 1/2" Sheet Metal Screw
	87053-EGO	Infinite Control 240V	N/S	88961	10-24 Green Hex Nut
8	56530	Indicator Light Amber	N/S	89025	10-24 Speed Nut
	56633	Indicator Light Green	N/S	89061	10-24 Hex Nut #10
9	69106	Limiting Thermostat	N/S	89059	Ext. Lockwasher
10	89101	Strain Relief Bushing US			N/S: NOT SHOWN



## APW WYOTT EQUIPMENT LIMITED WARRANTY

APW Wyott Foodservice Equipment Company warrants its equipment against defects in materials and workmanship, subject to the following conditions:

This warranty applies to the original owner only and is not assignable.

Should any product fail to function in its intended manner under normal use within the limits defined in this warranty, at the option of APW Wyott such product will be repaired or replaced by APW Wyott or its Authorized Service Agency. APW Wyott will only be responsible for charges incurred or service performed by its Authorized Service Agencies. The use of other than APW Wyott Authorized Service Agencies will void this warranty and APW Wyott will not be responsible for such work or any charges associated with same. The closest APW Wyott Authorized Service Agent must be used.

This warranty covers products shipped into the 48 contiguous United States, Hawaii, metropolitan areas of Alaska and Canada. There will be no labor coverage for equipment located on any island not connected by roadway to the mainland.

Warranty coverage on products used outside the 48 contiguous United States, Hawaii, and metropolitan areas of Alaska and Canada may vary. Contact the international APW Wyott distributor, dealer, or service agency for details.

### Time Period

One year for parts and one year for labor, effective from the date of purchase by the original owner. The Authorized Service Agency may, at their option, require proof of purchase. Parts replaced under this warranty are warranted for the un-expired portion of the original product warranty only.

### Exceptions

- \***Gas/Electric Cookline:** Models GCB, GCRB, GF, GGM, GGT, CHP-H, EF, EG, EHP. Three (3) Year Warranty on all component parts, except switches and thermostats. (2 additional years on parts only. No labor on second or third year.)
- \***Broiler Briquettes, Rock Grates, Cooking Grates, Burner Shields, Fireboxes:** 90 Day Material Only. No Labor.
- \***Heat Strips:** Models FD, FDL, FDD, FDDL. Two (2) Year Warranty on element only. No labor second year.
- \***Glass Windows, Doors, Seals, Rubber Seals, Light Bulbs:** 90 Day Material Only. No Labor.

In all cases, parts covered by extended warranty will be shipped FOB the factory after the first year.

### Portable Carry In Products

Equipment weighing over 70 pounds or permanently installed will be serviced on-site as per the terms of this warranty. Equipment weighing 70 pounds or under, and which is not permanently installed, i.e. with cord and plug, is considered portable and is subject to the following warranty handling limitations. If portable equipment fails to operate in its intended manner on the first day of connection, or use, at APW Wyott's option or its Authorized Service Agency, it will be serviced on site or replaced.

From day two through the conclusion of this warranty period, portable units must be taken to or sent prepaid to the APW Wyott Authorized Service Agency for in-warranty repairs. No mileage or travel charges are allowed on portable units after the first day of use. If the customer wants on-site service, they may receive same by paying the travel and mileage charges. Exceptions to this rule: (1) countertop warmers and cookers, which are covered under the Enhanced Warranty Program, and (2) toasters or rollergrills which have in store service.

### Exclusions

The following conditions are not covered by warranty:

- \*Equipment failure relating to improper installation, improper utility connection or supply and problems due to ventilation.
- \*Equipment that has not been properly maintained, calibration of controls, adjustments, damage from improper cleaning and water damage to controls.
- \*Equipment that has not been used in an appropriate manner, or has been subject to misuse or misapplication, neglect, abuse, accident, alteration, negligence, damage during transit, delivery or installation, fire, flood, riot or act of god.
- \*Equipment that has the model number or serial number removed or altered.

If the equipment has been changed, altered, modified or repaired by other than an Authorized Service Agency during or after the warranty period, then the manufacturer shall not be liable for any damages to any person or to any property, which may result from the use of the equipment thereafter.

This warranty does not cover services performed at overtime or premium labor rates. Should service be required at times which normally involve overtime or premium labor rates, the owner shall be charged for the difference between normal service rates and such premium rates. APW Wyott does not assume any liability for extended delays in replacing or repairing any items beyond its control.

In all cases, the use of other than APW Wyott Authorized OEM Replacement Parts will void this warranty.

This equipment is intended for commercial use only. Warranty is void if equipment is installed in other than commercial application.

### Water Quality Requirements

Water supply intended for a unit that has in excess of 3.0 grains of hardness per gallon (GPG) must be treated or softened before being used. Water containing over 3.0 GPG will decrease the efficiency and reduce the operation life of the unit.

**Note: Product failure caused by liming or sediment buildup is not covered under warranty.**

**"THE FOREGOING WARRANTY IS IN LIEU OF ANY AND ALL OTHER WARRANTIES EXPRESSED OR IMPLIED INCLUDING ANY IMPLIED WARRANTY OF MERCHANTABILITY OR FITNESS FOR PARTICULAR PURPOSES AND CONSTITUTES THE ENTIRE LIABILITY OF APW WYOTT. IN NO EVENT DOES THE LIMITED WARRANTY EXTEND BEYOND THE TERMS STATED HEREIN."**

9/05



---

Phone: +1 (214) 421-7366  
Fax: +1 (214) 565-0976  
Toll Free: +1 (800) 527-2100  
Website: [www.apwwyott.com](http://www.apwwyott.com)  
E-mail: [info@apwwyott.com](mailto:info@apwwyott.com)

**APW WYOTT**  
729 Third Avenue  
Dallas, TX 75226