



**ELECTRIC DROP-IN GRIDDLE
MODEL EGD
PARTS MANUAL**



THIS MANUAL IS FOR EGD MODELS STARTING WITH SERIAL NUMBER 7547
SP8028-1203

TABLE OF CONTENTS

DESCRIPTION	PAGE
TABLE OF CONTENTS	1
DOCUMENT HISTORY	1
GRIDDLE ASSEMBLY	2
CONTROL BOX, CONTROL PANEL & HIGH LIMIT ASSEMBLY	3
CONTROL BOX ASSEMBLY	4-5
HIGH LIMIT OVERTEMP ASSEMBLY	6
CONTACT INFORMATION	7

DOCUMENT HISTORY

CURRENT REVISION	DATE	PRIOR REVISION	DATE	CHANGE
1203	3/28/12	N/A	N/A	INITIAL RELEASE

GRIDDLE ASSEMBLY

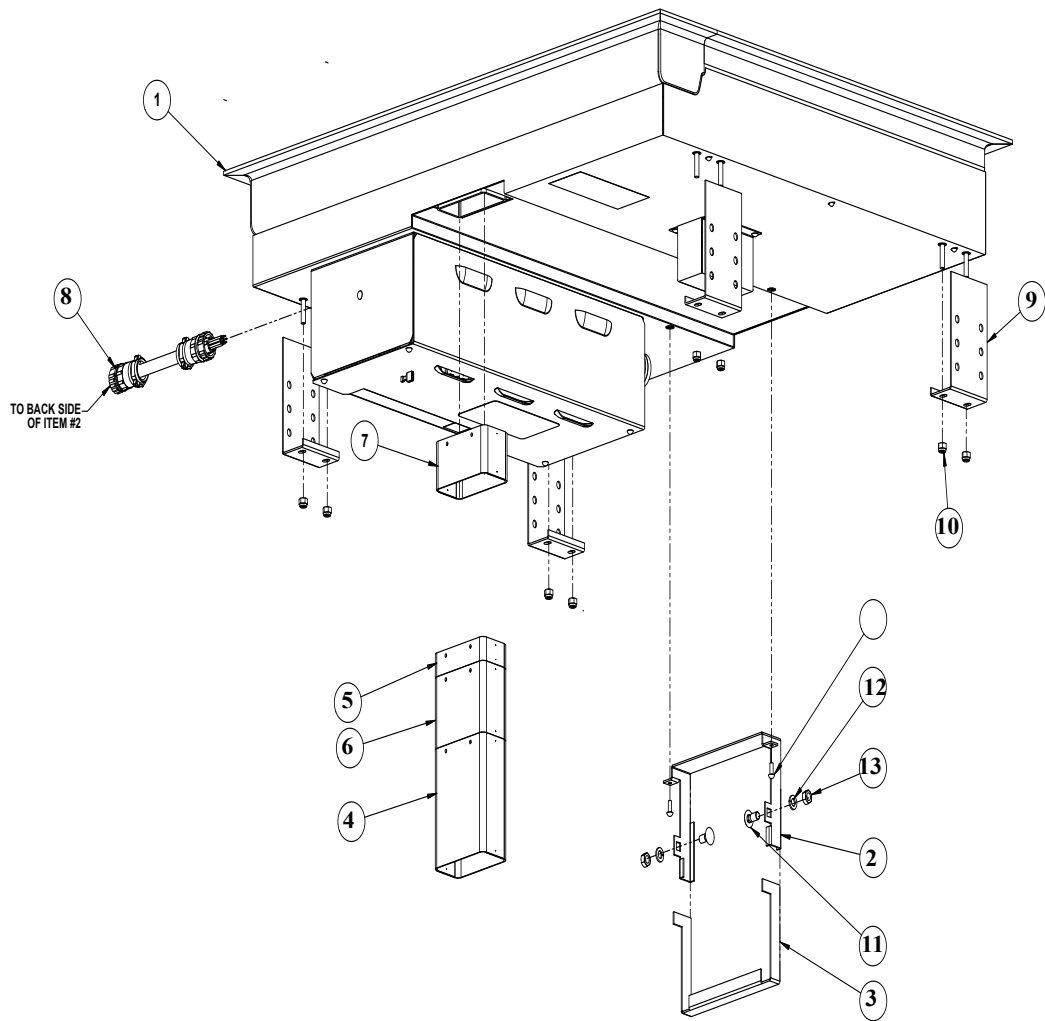

ITEM	PART NUMBER	DESCRIPTION
1	AT2A-2520	GRIDDLE ASSEMBLY
2	AT2M-2553-1	GREASE TROUGH HANGER BRACKET
3	AT2M-2554-1	GREASE TROUGH HANGER
4	AT2A-2592-5	5" GREASE SPOUT EXTENSION
5	AT2A-2592-1	1" GREASE SPOUT EXTENSION
6	AT2A-2592-3	3" GREASE SPOUT EXTENSION
7	AT2A-2592-2	2" GREASE SPOUT EXTENSION
8	AT2A-2764-1	CABLE ASSEMBLY
9	AT2M-2535-1	RETAINER BRACKET
10	AT0F-2691-51002	NUT, 1/4-20 NYLOC
11	AT0F-1921-61060	BOLT, 5/16-18 UNC 2A X 3/4" CARRIAGE
12	AT0F--1922-6000	WASHER, 5/16" HELICAL SPRING LOCK
13	AT0F-2778-61000	NUT, 5/16-18UNC--2B SS HEX MACHINE SCREW
14	AT0F-2755-41040	SCREW, #10-24UNC X 1/2 PHILIPS ROUND HEAD

CONTROL BOX, CONTROL PANEL & OVERTEMP ASSEMBLY

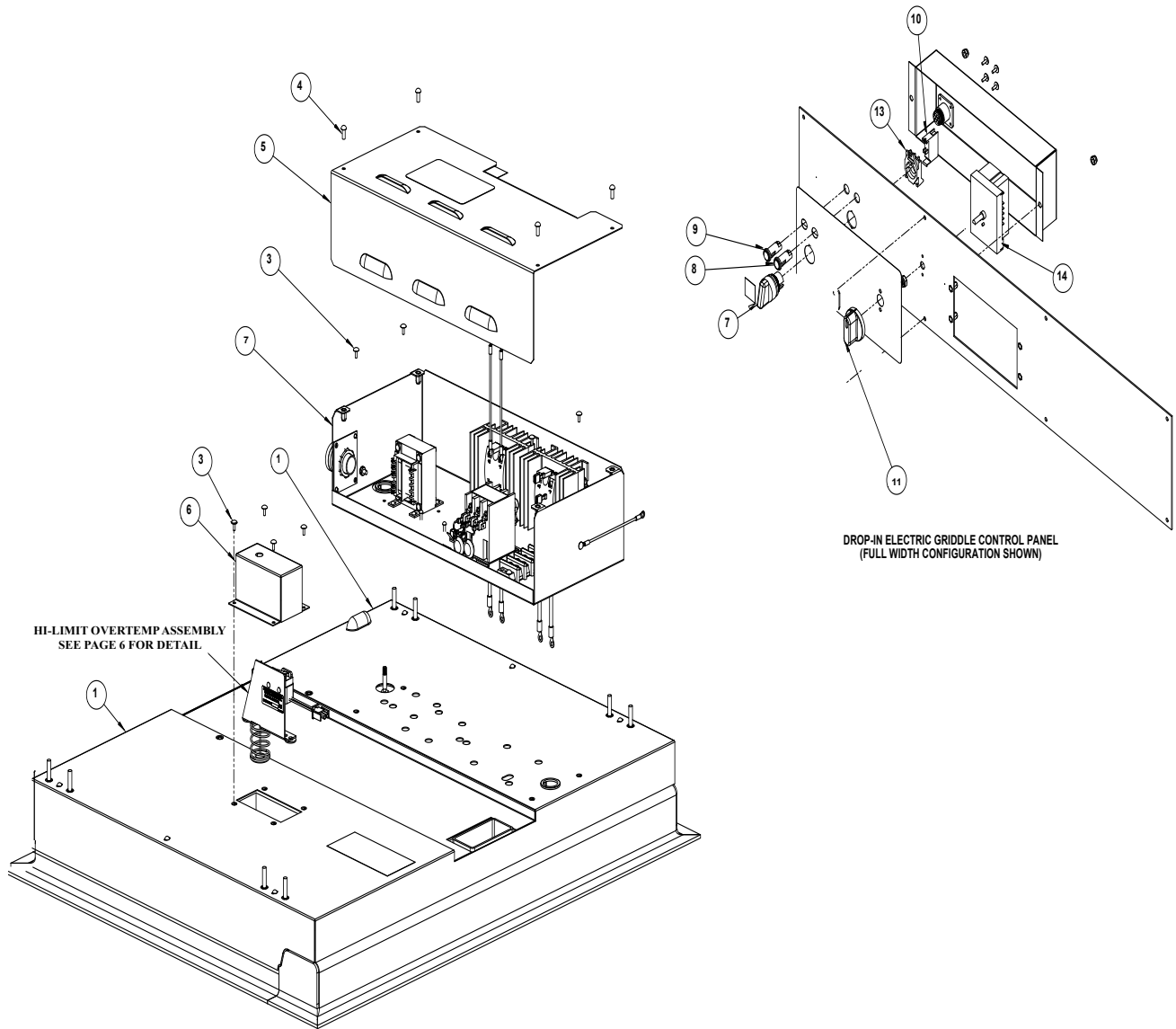

ITEM	PART NUMBER	DESCRIPTION
1	AT2A-2520	GRIDDLE ASSEMBLY
2	AT2A-2577-4	CONTROL BOX ASSEMBLY
3	AT0F-2777-31030	SCREW, #8 TYPE AB X 3/8 TRUSS GD
4	AT0F-2755-41040	SCREW, #10-24UNC X 1/2 PHILIPS ROUND HEAD MACHINE
5	AT2M-2646-1	COVER CONTROL BOX
6	AT2M-1559-2	COVER
7	AT0E-3336-1	SWITCH
8	AT0E-1800-1	INDICATOR LAMP, GREEN 28 V
9	AT0E-1800-2	INDICATOR LAMP, RED 28 V
10	AT0E-3338-1	CONTACT BLOCK
11	AT0H-1455-2	KNOB FOR D SHAFT
13	AT0E-3339-1	MOUNTING LATCH
14	AT0E-2559-6	TEMPERATURE CONTROLLER, RTD
15	AT0E-2885-5	TEMPERATURE SENSOR, RTD - NOT SHOWN

CONTROL BOX ASSEMBLY AT2A-2577-4

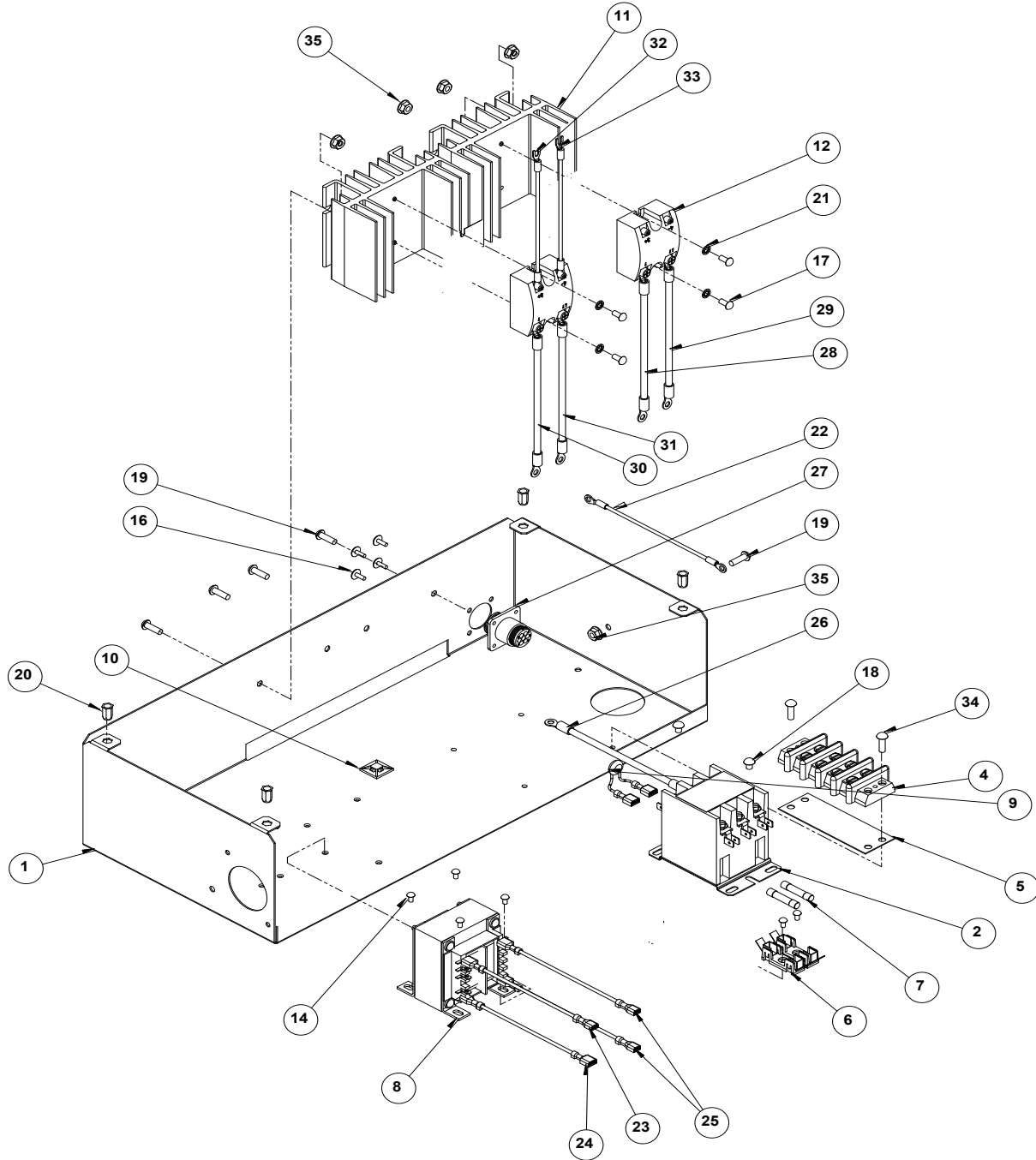

CONTROL BOX ASSEMBLY
AT2A-2577-4

ITEM	PART NUMBER	DESCRIPTION
1	AT2M-2560-3	BOX, CONTROL
2	AT0E-1587-4	3 POLE CONTACTOR
4	AT0E-1134-4	4 POSITION TERMINAL BLOCK
5	AT0E-3025-2	INSULATOR STRIP, DOUBLE ROW
6	AT0E-2708-1	3AG OMNI BLOK FUSE BLOCK 2 POS
7	AT0E-2731-2	FUSE, 1 1/4 AMP 250V
8	AT0E-2662-5	TRANSFORMER
9	AT0A-2736-8	MOV, TERMINALS ASSEMBLY
10	AT0H-2887-1	CABLE TIE MOUNT
11	AT0E-2206-3	HEAT SINK, 3.43" LONG
12	AT0E-2059-3	RELAY, SOLID STATE
14	AT0E-2755-21020	SCREW, #6-32UNC X 1/4 PHILPS ROUND HEAD MACHINE
15	AT0E-2755-21020	SCREW, #6-32UNC X 5/8 PHILPS ROUND HEAD MACHINE
16	AT0F-2777-31030	SCREW, #8 TYPE AB X 3/8 TRUSS HD
17	AT0F-2755-31030	SCREW, #8-32UNC X 3/8 PHILPS ROUND HEAD MACHINE
18	AT0F-2755-41020	SCREW, #10-24UNC X 1/4 PHILPS ROUND HEAD MACHINE
19	AT0F-2755-41050	SCREW, #10-24UNC X 5/8 PHILPS ROUND HEAD MACHINE
20	AT0F-2668-1	NUTSERT, #10-24 HEX
21	AT0F-2666-30000	WASHER, #8 INTERNAL TOOTH LOCK
22	AT0A-2761-1	HARNESS ASSEMBLY RING TERM TO RING TERM
23	AT0A-2615-2	WIRE HARNESS
24	AT0A-2615-3	WIRE HARNESS
25	AT0A-2615-4	WIRE HARNESS
26	AT0A-2617-1	5.0" HIGH TEMP WIRE ASSEMBLY WHITE
27	AT0A-2760-6	CABLE ASSEMBLY
28	AT0A-2617-3	5.0" HIGH TEMP WIRE ASSEMBLY RED
29	AT0A-2617-31	6.0" HIGH TEMP WIRE ASSEMBLY RED
30	AT0A-2617-32	7.0" HIGH TEMP WIRE ASSEMBLY BLACK
31	AT0A-2617-33	8.0" HIGH TEMP WIRE ASSEMBLY BLACK
32	AT0A-3178-1	HARNESS ASSEMBLY FORK TERM TO FORK TERM
33	AT0A-3178-2	HARNESS ASSEMBLY FORK TERM TO FORK TERM
34	AT0F-2755-41052	SCREW, #10-24UNC X 5/8 PHILIPS ROUND HEAD MACHINE
35	AT0F-1017-41002	NUT, #10-24UNC HEX SERRATED

HIGH LIMIT OVERTEMP ASSEMBLY AT2A-2916-1

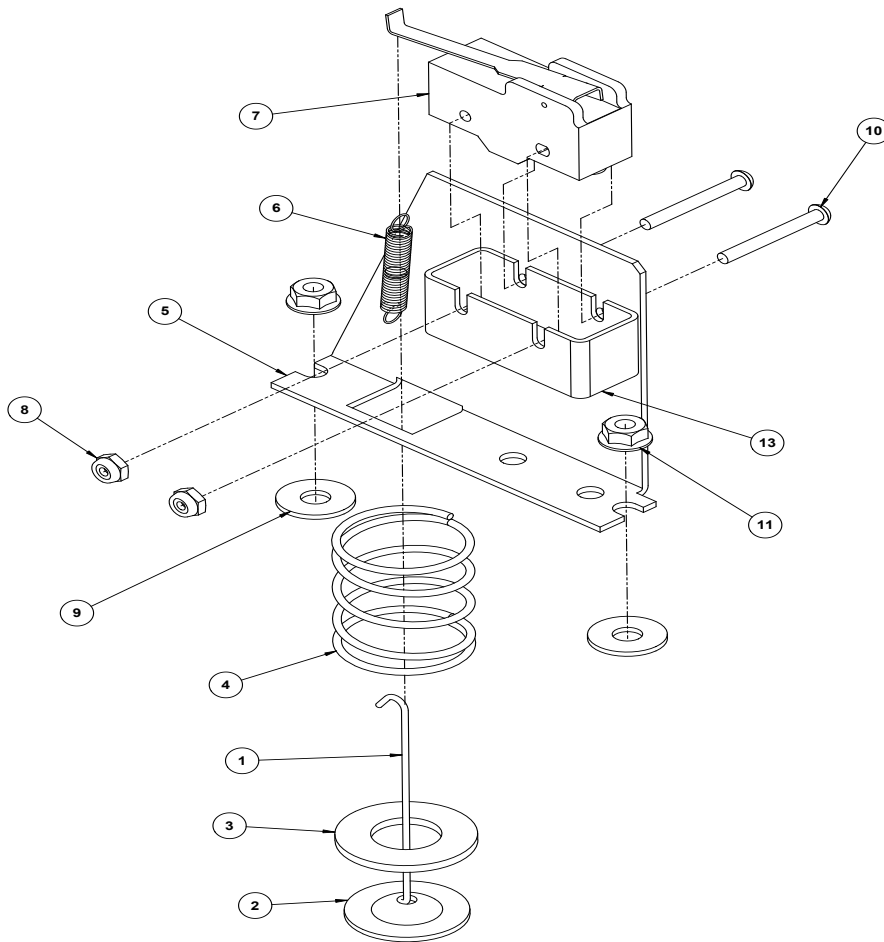

HIGH LIMIT OVERTEMP ASSEMBLY
DETAIL VIEW

ITEM	PART NUMBER	DESCRIPTION
1	AT2M-2861-1	WIRE ROD, OVERTEMP
2	AT2M-2860-1	SOLDER WASHER OVERTEMP
3	AT0F-1367-1	WASHER, TYPE A
4	AT2H-1365-1	COMPRESSION SPRING
5	AT2M-1558-1	BRACKET SWITCH LEFT HAND
6	AT2H-1640-1	EXTENSION SPRING
7	AT2E-1639-1	MICROSWITCH
8	AT0F-2691-21002	NUT, #6-32 NYLOC
9	AT0F-1052-51002	WASHER 1/4 TYPE B PLAIN ZINC PLATED
10	AT0F-2755-21102	SCREW, #6-32UNC X 1 1/4 PHILI ROUND HEAD MACHINE
11	AT0F-1017-41002	NUT, #10-24UNC HEX SERRATED



INFORMATION

IMPORTANT SERVICE INFORMATION

AccuTemp Product, Inc. Technical & Customer Support Technician is available Monday thru Sunday, 7:00am to 7:00pm EST

800 480-0415 or 260 469-3040

- **Phone - 800 480-0415 or 260 469-3040**
- **Fax - 260 469-3045**
- **Email - service@accutemp.net**
- **Web site - www.accutemp.net**