

ELECTRIC GRIDDLE PARTS MANUAL

**MODEL EGF4403B3605-T3
MODEL EGF4803B3605-T3**

THIS MANUAL IS FOR MODELS STARTING WITH SERIAL NUMBER 7642

TABLE OF CONTENTS

DESCRIPTION	PAGE
TABLE OF CONTENTS	1
DOCUMENT HISTORY	1
GRIDDLE ASSEMBLY	2-4
CONTROL PANEL ASSEMBLY	5
HIGH LIMIT OVERTEMP ASSEMBLY	6
CONTACT INFORMATION	7

DOCUMENT HISTORY

CURRENT REVISION	DATE	PRIOR REVISION	DATE	CHANGE
1110	10/27/11	N/A	10/27/11	INITIAL RELEASE

MODELS
EGF4403B3605-T3
EGF4803B3605-T3

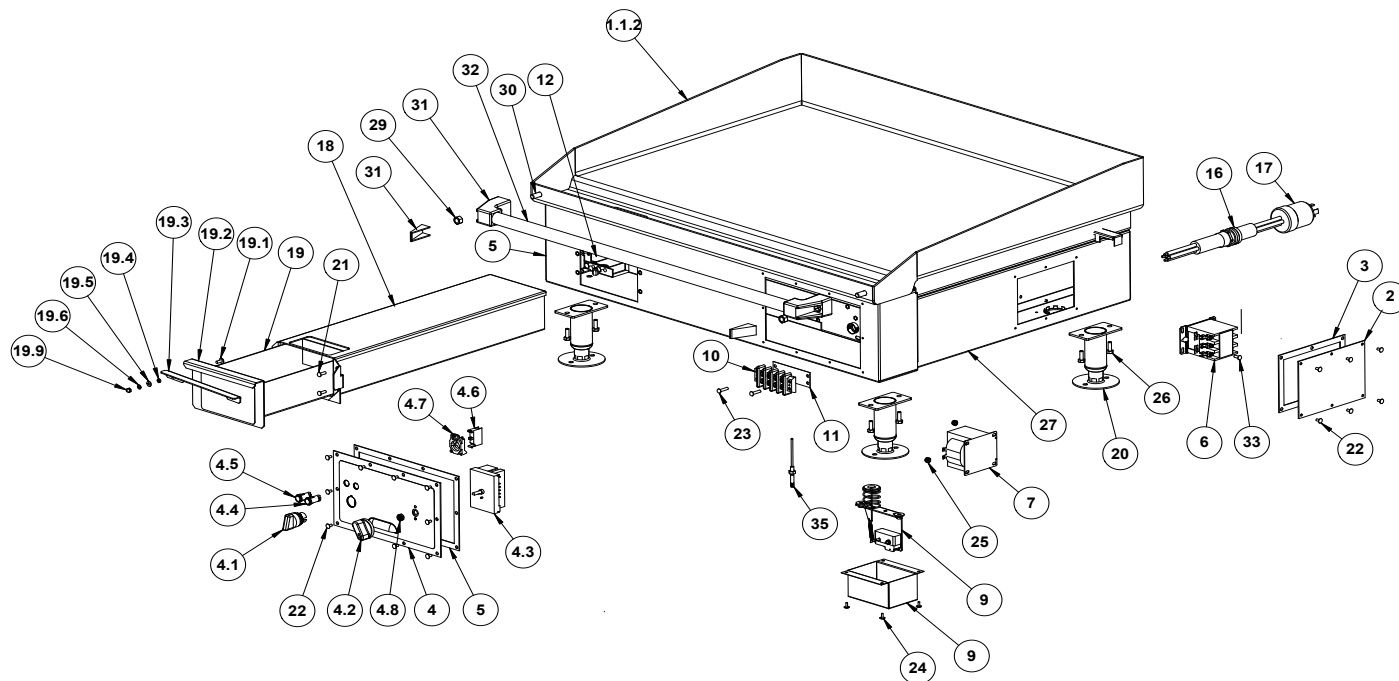

ITEM NUMBER	PART NUMBER	DESCRIPTION
1.1.2	AT2A-2185	WELD ASSY, CHAMBER
2	AT2M-1021-1	PANEL, EGF ACCESS POWER TERMINAL
3	AT2G-1022	GASKET PANEL ACCESS POWER TERMINAL, EG
4	AT2A-3189-1	ASSY, EXT THERM CONTROL PANEL
4.1	AT0E-3336-1	OPERATOR, AB ROTARY SWITCH
4.2	AT0H-1455-2	KNOB FOR D SHAFT
4.3	AT0E-2559-7	TEMPERTURE CONTROLLER
4.4	AT0E-1800-4	INDICATOR LAMP GRN NEON 250V
4.5	AT0E-1800-5	INDICATOR LAMP RED NEON 250V
4.6	AT0E-3338-1	CONTACT BLOCK
4.7	AT0E-3339-1	MOUNTING LATCH
4.8	AT0F-3371-1	NUT, ROTARY SEAL
5	AT0G-1026-1	GASKET, CONTROL PANEL, EG
6	AT0E-1587-1	3 POLE CONTACTOR
7	AT0E-2662-3	TRANSFORMER
8	AT2A--2916-1	HIGH LIMIT OVERTEMP ASSEMBLY
9	AT2M-1559-1	COVER
10	AT0E-1134-4	4 POSITION TERMINAL BLOCK
11	AT0E-3025-2	INSULATOR STRIP, DOUBLE ROW
16	AT0E-1049-5	CONNECTOR, 1" HUB STRAIN RELIEF
17	AT0A-2788-14	POWER CABLE ASSEMBLY
17.2	AT2E-2567-6	CABLE 6 AWG 4 COND
18	AT2A-2529-2	GREASE TROUGH ASSY

MODELS
EGF4403B3605-T3
EGF4803B3605-T3

ITEM NUMBER	PART NUMBER	DESCRIPTION
19	AT2A-2552-2	ASSY, BAFFLED LOCKING GREASE TRAY
19.1	AT0F-1046-41040	SCREW, #10-24X 1/2 PHLP TRUSS HEAD
19.2	AT2M-2551-2	GREASE TRAY FACE PLATE
19.3	AT2M-3008-1	LEVER, GREASE PAN
19.4	AT0F-3012-1	SPACER, ROUND
19.5	AT0F-1052-43010	WASHER, # 10 TYPE B CUSTOM
19.6	AT0F-1922-40000	WASHER, #10 SS HELICAL SPRING LOCK
19.9	AT0F-2632-41001	NUT, A0-24 ACORN
20	AT2A-3032-3	3" LEG ASSEMBLY
21	AT0F-2755-41050	SCREW, #10-24UNC X 5/8 PHILIPS ROUND HEAD MACHINE
22	AT0-1046-31030	SCREW, #8-32 X 3/8 TYPE AB PHILIPS TRUSS HEAD
23	AT0F-2755-41070	SCREW, #10-24UNC X 7/8 PHILIPS ROUND HEAD MACHINE
24	AT0F-2777-31030	SCREW, #8-32 X 3/8 TYPE AB TRUSS HEAD
25	AT0F-2691-41002	NUT, #10-24 NYLOC
26	AT0F-2875-51062	SCREW, 1/4-20UNC X 3/4 HEX HEAD MACHINE
29	AT0F-2778-71001	NUT, 3/8 UNC SS
30	AT0F-2875-71080	SCREW, 3/8-16UNC X 1 HEX HEAD MACHINE
31	AT0H-3184-1	END BRKTS, GRIDDLE GRAB BAR
32	AT2M-3183-2	36" GRIDDLE GRAB
33	AT0F-2755-41040	SCREW, #10-24UNC X 1/2 PHILIPS ROUND HEAD MACHINE
35	AT0E-2885-3	SENSOR REPLACEABLE
56	AT2A-3227-2	ASSY, 36" GRIDDLE FRONT 36" SKIRT
57	AT2M-3464-5	SKIRT, FRONT 36" MARITIME
56.2	AT0F-2668-1	NUTSERT, 10-24 HEX

MODELS
EGF4403B3605-T3
EGF4803B3605-T3

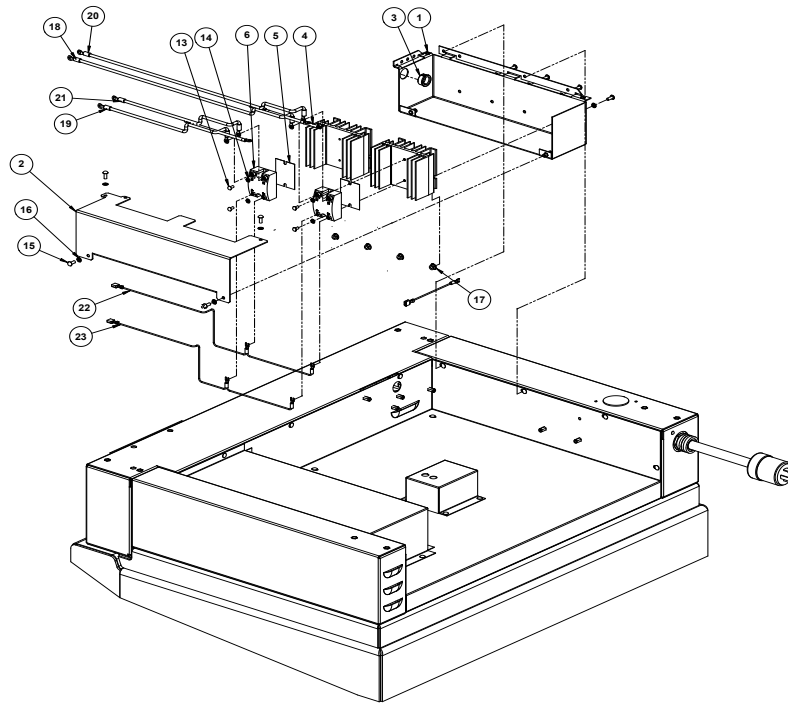

ITEM NUMBER	PART NUMBER	DESCRIPTION
1	AT2M-3103-1	CHASSIS, RELAY ENCLOSURE
2	AT2M-3104-1	COVER RELAY ENCLOSURE
3	AT0H-2576-1	GROMMET, 7/8 NYLON
4	AT0E-2206-3	HEAT SINK, 3.43" LONG
5	AT0E-2296-1	PAD, SSR HEAT SINK
6	AT0E-2059-3	RELAY SOLID STATE
7	AT0A-3111-1	CONTROL INPUT HARNESS
8	AT0A-3111-2	CONTROL INPUT HARNESS
9	AT0A-3112-4	ASSY, HARNESS
10	AT0A-3112-3	ASY, HARNESS
11	AT0A-3112-2	ASSY, HARNESS
12	AT0A-3112-1	ASSY HARNESS
13	AT0F-2755-31040	SCREW, #8-32UNC X 1/2 PHILIPS ROUND HEAD MACHINE
14	AT0F-2666-40000	WASHER, #8 INTERNAL TOOTH LOCK
15	AT0F-2755-31040	SCREW, #10-24UNC X 1/2 PHILIPS ROUND HEAD MACHINE
16	AT0F-2666-40000	WASHER INTERNAL TOOTH LOCK
17	AT0F-1017-41002	NUT, #10-24UNC HEX SERRATED
24	AT0F-2668-1	NUTSERT, #10-24 HEX

AT2A-3189 - ASSEMBLY, ELECTRIC CONTROL PANEL

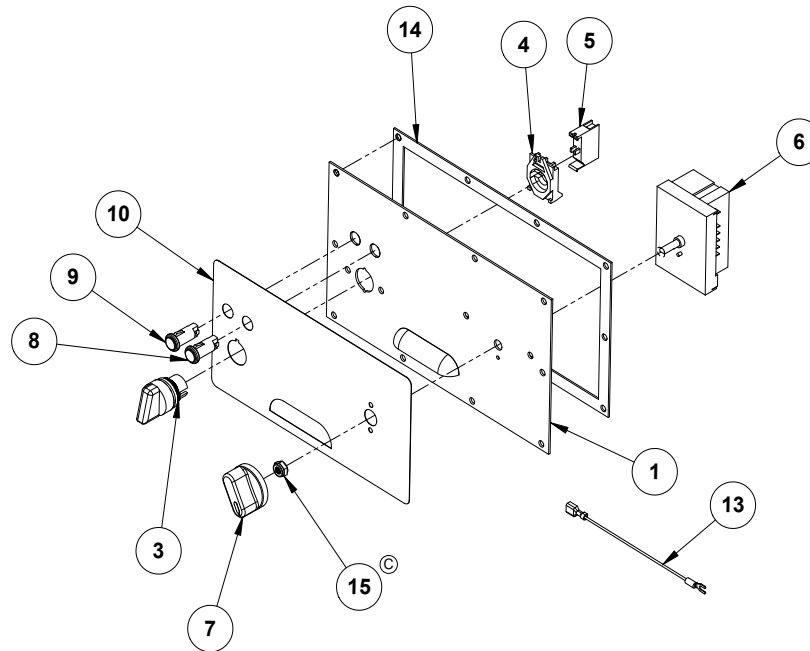

ITEM NUMBER	PART NUMBER	DESCRIPTION
1	AT2A-3243-1	ASSY, EG CONTROL PANEL WELDMENT
3	AT0E-3336-1	OPERATOR, AB ROTARY SWITCH
4	AT0E-3339-1	MOUNTING LATCH
5	AT0E-3338-1	CONTACT BLOCK
6	AT0E-2559-7	TEMPERATURE CONTROLLER
7	AT0E-1455-2	KNOB FOR D SHAFT
8	AT0E-1800-4	INDICATOR LAMP GRN NEON 250V
9	AT0E-1800-5	INDICATOR LAMP RED NEON 250V
10	AT0E-2715-3	OVERLAY CONTROL PANEL
13	AT2A-3283-1	ASSY, WIRE HARNESS
14	AT2G-1026	GASKET CONTROL PANEL, EG
16	AT0F-3371-1	NUT, ROTARY SHAFT SEAL

AT2A-2916-1- HIGH LIMIT OVERTEMP ASSEMBLY

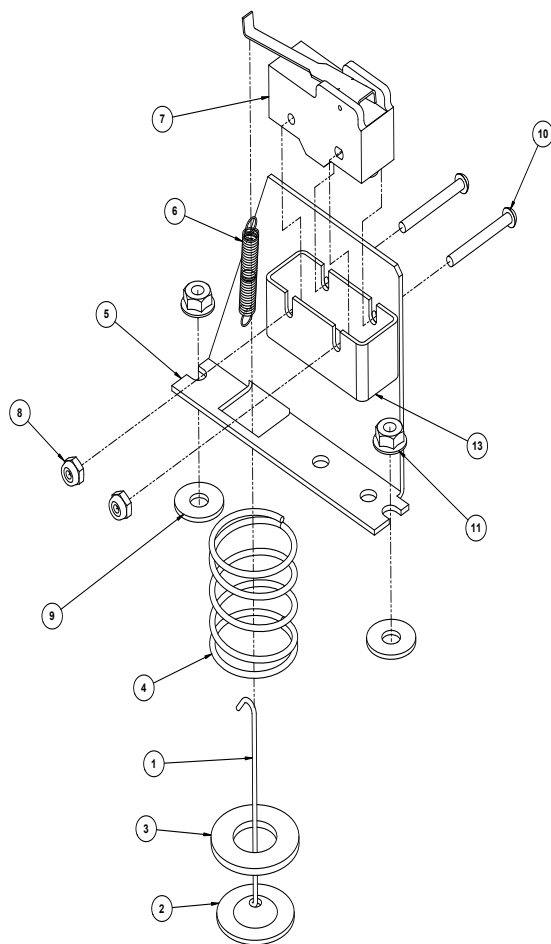

HIGH LIMIT OVERTEMP ASSEMBLY
DETAIL VIEW

ITEM NUMBER	PART NUMBER	DESCRIPTION
1	AT2M-2861-1	WIRE ROD, OVERTEMP
2	AT2M-2860-1	SOLDER WASHER OVERTEMP
3	AT0F-1367-1	WASHER, TYPE A
4	AT2H-1365-1	COMPRESSION SPRING
5	AT2M-1558-1	BRACKET SWITCH LEFT HAND
6	AT2H-1640-1	EXTENSION SPRING
7	AT2E-1639-1	MICROSWITCH
8	AT0F-2691-21002	NUT, #6-32 NYLOC
9	AT0F-1052-51002	WASHER 1/4 TYPE B PLAIN ZINC PLATED
10	AT0F-2755-21102	SCREW, #6-32UNC X 1 1/4 PHILIOS ROUND HEAD MACHINE
11	AT0F-1017-41002	NUT, #10-24UNC HEX SERRATED



INFORMATION

IMPORTANT SERVICE INFORMATION

AccuTemp Product, Inc. Technical & Customer Support Technician is available Monday thru Sunday, 7:00am to 7:00pm EST

800.480.0415 or 260.469.3040

- Phone - 800 480-0415 or 260 469-3040
- Email - service@accutemp.net
- Web site - www.accutemp.net