



# ACCU-STEAM™ GAS GRIDDLE OWNERS MANUAL

## IMPORTANT WARRANTY INFORMATION:

For product warranty activation, the *ACCU-STEAM™* Griddle Start-Up Form and the Product Registration Form must be submitted to AccuTemp Products, Inc. after installation of the appliance.



*ACCU-STEAM™* Griddle Start-Up Form

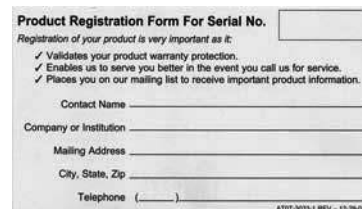

Product Registration Form

---

---

## **IMPORTANT FOR YOUR SAFETY**

These installation instructions have been prepared for qualified gas equipment installation personnel, who should perform the initial field start-up and complete the equipment adjustments described in this manual.

The safety instructions listed below on this page should be posted in a prominent location as a reminder of safe practices as well as recommended actions to follow in the event of an equipment or facility utility issue.

### **WARNING**

**In the event a gas odor is detected, shut down all appliances at the main gas shut-off valve and contact the local gas company or gas supplier for service.**

### **WARNING**

**In the event of a power failure, do not attempt to operate this appliance.**

### **WARNING**

**Do not store or use gasoline or other flammable vapors or liquids in the vicinity of this or any other appliance.**

### **WARNING**

**Improper installation, adjustment, alteration, service or maintenance can cause property damage, injury or death. Read the installation, operating, and maintenance instructions thoroughly before installing or servicing this equipment.**

## **Retain this Manual for future reference**

# DOCUMENT HISTORY

---

Current revision: –	Prior revision: None
Date: 2/28/06	Date: None

Change  
Initial release.

---

Current revision: A	Prior revision: –
Date: 3/14/06	Date: 2/28/06

## Change

Page 4 – Added unpacking information.

Page 5 – Added tipping warning.

Page 8 – Added reference to warranty card

Page 10 – Added second supplier for suggested cleaning products.

Page 19 – Added Pilot Burner Assembly service parts drawing.

Page 25 – Revised and moved Start-Up Form.

---

Current revision: B	Prior revision: A
Date: 6/30/06	Date: 3/14/06

## Change

Page 4 – Added warning information.

Page 7 – Modified Electrical Requirements section.

Pages 8 & 9 – Modified Gas Connection section.

Page 10 – Revised reference for Product Registration Form.

Page 12 – Added second supplier for suggested cleaning products.

Page 16 – Added Orifice Table.

Page 22 – Added Pilot Burner Assembly service parts drawing.

FS3803-0607 – Revised and moved Start-Up Form to the end of this manual.

---

Current revision: C	Prior revision: B
Date: 7/11/08	Date: 6/30/06

## Change

Page ii - Revised Table of Contents to Match Document

Page 16 – Added Gas Appliance STD Conversion Kit Drawing

Page 27 Added High Limit Overtemp Assembly Parts Drawing

FS 3805-0804 – Added Preventive Maintenance Recommendation Form

---

# TABLE OF CONTENTS

---

---

<b>DOCUMENT HISTORY</b>	<b>i</b>
<b>TABLE OF CONTENTS</b>	<b>ii</b>
<b>SAFETY WARNINGS</b>	<b>1 – 2</b>
<b>THEORY OF OPERATION</b>	<b>3</b>
<b>INSTALLATION</b>	<b>4 – 10</b>
<b>OPERATION</b>	<b>11 – 12</b>
<b>SERVICE AND TROUBLESHOOTING</b>	<b>13 – 15</b>
<b>Gas Conversion Kit</b>	<b>16</b>
<b>GAS GRIDDLE ORIFICE REFERENCE TABLE FOR ALITITUDE AND BTU CONTENT</b>	<b>17</b>
<b>GAS GRIDDLE ASSEMBLY SERVICE PARTS</b>	<b>18 – 19</b>
<b>COMBUSTION CHAMBER ASSEMBLY SERVICE PARTS</b>	<b>20 – 22</b>
<b>PILOT BURNER ASSEMBLY SERVICE PARTS</b>	<b>23</b>
<b>GAS CONTROL VALVE ASSEMBLY SERVICE PARTS</b>	<b>24</b>
<b>CONTROL PANEL SERVICE PARTS</b>	<b>25 – 26</b>
<b>HIGH LIMIT OVERTEMP ASSEMBLY</b>	<b>27</b>
<b>GAS GRIDDLE SCHEMATIC</b>	<b>28</b>
<b>WARRANTY</b>	<b>29</b>
<b>ACCU-STEAM GAS GRIDDLE START-UP FORM</b>	<b>FS3803-0607</b>
<b>ACCU-STEAM GAS GRIDDLE PREVENTIVE MAINTENANCE FORM</b>	<b>FS3805-0804</b>

# SAFETY WARNINGS

---

---

## **SYMBOL DEFINITIONS**

Symbols are used to attract your attention to possible dangers. They are only effective if the operator uses proper accident prevention measures. Some of the symbols are boxed text, while other maybe just picture icons. Please give this information the respect they deserve for safe operation.

## **WARNING TEXT BOXES**

Below are definitions of the warning text boxes:

### **DANGER**

**Indicates an imminently hazardous situation which, if not avoided, will result in death or serious injury.**

### **WARNING**

**Indicates a potentially hazardous situation which, if not avoided, could result in death or serious injury.**

### **CAUTION**

**Indicates a potentially hazardous situation which, if not avoided, could result in minor or moderate injury.**

### **NOTE**

**Advises reader of information or instructions vital to the operation or maintenance of the equipment.**

# SAFETY WARNINGS (cont.)

---

---

## SYMBOL ICONS

Below are definitions of symbol icons used in this manual:

**ALERT** – Notifies the reader of an important message/warning, usually a safety related message.



**INFORMATION** – Notifies the reader of important information that may or may not be safety-related.



## EARTH GROUND



## DANGEROUS VOLTAGE



## CAUTION, HOT SURFACE



# THEORY OF OPERATION

## INTRODUCTION

The **ACCU-STEAM™** griddle is constructed and uses technology like no other griddle in the world. The diagram below is a cross-sectional view of the griddle. The griddle cooking surface is the top of a chamber in which we have produced a unique environment. Welded stainless steel reinforcement studs connect the chamber top to the chamber bottom. The perimeter joints are all robotically welded and produce a vessel that is airtight, which is verified using a helium mass spectrometer. The chamber is filled half full with distilled water. The remaining air is removed and the chamber is welded shut. At this point, the chamber becomes a hermetically sealed vessel, never to be opened again. **The griddle steam chamber requires no water or maintenance.** A thermowell for a thermocouple to sense temperature and a thermowell for the overtemp safety shutdown system are also welded into the griddle steam chamber.



### Generating Steam In Gas-Heated Models

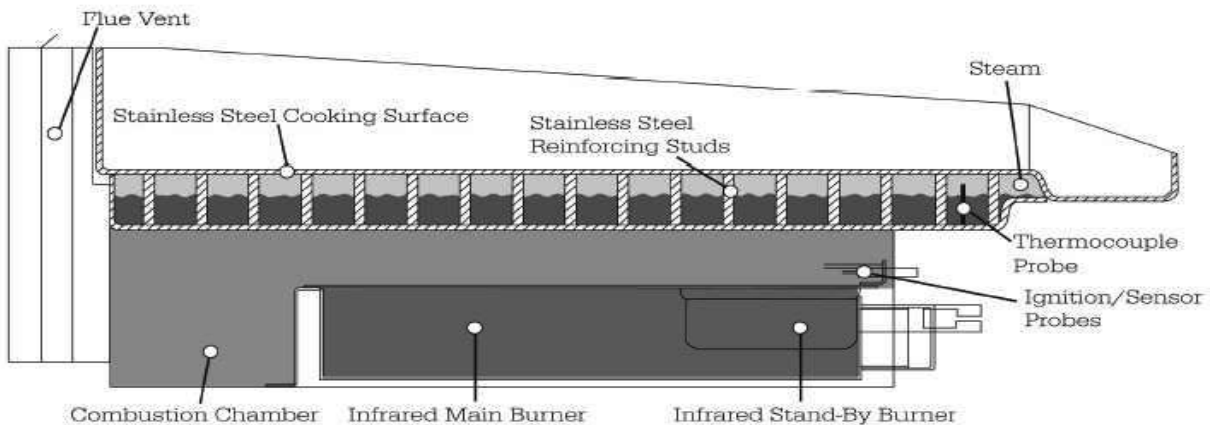

At temperatures below 212°F (100°C), the chamber is actually in a vacuum, similar to that of a canning jar. At temperatures above 212°F (100°C), the chamber operates under pressure. Located between the water and the bottom of the cooking surface is the best heat transfer medium – steam, the most effective way to transfer heat. The thermocouple senses the temperature of the steam and reports this data to the thermostat, which ignites the burners. This system maintains the griddle cooking surface temperatures to within  $\pm 3^\circ\text{F}$  (1.7°C) over the entire cooking surface and provides a near instant temperature recovery, even in the same spot on the griddle, when turning food in place.

# INSTALLATION

## WARNING

**Only qualified service technicians/electricians should perform the installation to ensure that all electrical and safety requirements are met and that all wiring is performed in accordance with all national, state and local electrical codes.**

This installation must conform with local codes, or in the absence of local codes, with ***National Fuel Gas Code, ANSA/NFPA 54***, or the ***Natural Gas and Propane Installation Code, CSA B149.1***, as applicable.

**The appliance and its individual shutoff must be disconnected from the gas supply piping system during any pressure testing of that system at test pressures in excess of 1/2 psi (3.5kPa)**

**The appliance must be isolated from the gas supply piping system by closing its individual manual shut off valve during any testing of the gas supply piping system at a test pressure equal to or less than 1/2 psi (3.5kPa).**

### LOCATION AND PLACEMENT

The AccuTemp **ACCU-STEAM™** gas griddle can be placed on a commercial kitchen counter-top or AccuTemp griddle stand.

The operating temperature ranges from 200°- 400°F (93°- 204°C). Since these temperatures can also be found on surfaces around the perimeter of the griddle, care should be given not to install griddle next to or against, objects or surfaces with a low melting or flash point. See Figure 1 for clearance restrictions.

CLEARANCE RESTRICTIONS		
	COMBUSTIBLE	NON-COMBUSTIBLE
SIDES	1"	0"
REAR	2"	0"

Figure 1

## CAUTION

**Temperatures on and around the griddle cooking surface could cause severe burns.**



# INSTALLATION (cont.)

---

---

Provisions should be incorporated in the design of the kitchen, to ensure an adequate supply of fresh air for proper combustion and ventilation. When installing, never enclose the bottom of the unit with a raised curb or any other construction that would obstruct the flow of air into the unit.

## UNPACKING

This appliance was carefully inspected before shipment from the factory. The transportation company assumes full responsibility for safe delivery to the customer until customer acceptance of this packaged appliance.

## GRIDDLE LIFTING

Griddles are heavy enough to require additional manpower or powered assistance when installing or moving the griddle.

## CAUTION

**This appliance is heavy. For safe handling, the installer should obtain help as needed or employ appropriate material handling equipment to remove the appliance from the skid and move into its final destination.**

## LEVELING

The griddle must be installed in a level condition. An out-of-level condition may cause damage to the griddle and damage of this type is not covered by the limited warranty. Use a spirit level resting on the griddle surface to ensure it is level front-to-back and left-to-right.

**If this is a counter-top installation, the griddle must be set and leveled using the adjusters on the legs before installing the (4) rubber foot tips provided with the griddle.** The installation of the 4 rubber tips will keep the griddle from sliding on the counter-top under normal use.

If your griddle is attached to an AccuTemp stand with casters, ensure that the floor surface is level and place the two locking casters to the "on" position.

## STAND INSTALLATION

All griddle installations utilizing an AccuTemp stand with casters, shall be made with a connector that complies with the ***Standard for Connectors for Movable Gas Appliances, ANSI Z21.69 or CAN/CGA 6.16*** and a quick disconnect device that complies with the ***Standard for Quick Disconnect Devices for Use With Gas Fuel, ANSI Z21.41 or CAN 1-6.9.***



## INSTALLATION (cont.)

---

---

Adequate means must be provided to limit the movement of the stand without depending on the connector and the quick-disconnect device or its associated piping to limit movement. The restraining device shall be mounted to the rear leg supports of the stand.

### WARNING



**When the griddle is mounted on a stand with casters, the floor surface must be level. If the floor is not level, the griddle and stand may become unstable, such that tipping may occur, causing serious injury.**

### IN-FIELD MODIFICATIONS

**This griddle has a totally unique design and is constructed unlike any other griddle on the market today. Any modification may permanently damage the griddle and void the warranty.**

### WARNING



**Any in-field modification made without written authorization from AccuTemp will void all warranties.**

### DANGER



**Any in-field modifications that bypass the built-safety features of this product will result in death or serious injury.**

### ELECTRICAL SUPPLY

The **ACCU-STEAM™** griddle has been designed, manufactured and tested to meet or exceed the demanding standards of safety set forth by *Underwriters Laboratories, Inc.* To ensure that this high level of safety is maintained in your installation, it is important that you read and understand the following information before attempting to plug in your griddle.

# INSTALLATION (cont.)

---

Provisions should be incorporated in the design of the kitchen, to ensure an adequate supply of fresh air for proper combustion and ventilation. When installing, never enclose the bottom of the unit with a raised curb or any other construction that would obstruct the flow of air into the unit.

## UNPACKING

This appliance was carefully inspected before shipment from the factory. The transportation company assumes full responsibility for safe delivery to the customer until customer acceptance of this packaged appliance.

## GRIDDLE LIFTING

Griddles are heavy enough to require additional manpower or powered assistance when installing or moving the griddle.

## CAUTION

**This appliance is heavy. For safe handling, the installer should obtain help as needed or employ appropriate material handling equipment to remove the appliance from the skid and move into its final destination.**

## LEVELING

The griddle must be installed in a level condition. An out-of-level condition may cause damage to the griddle and damage of this type is not covered by the limited warranty. Use a spirit level resting on the griddle surface to ensure it is level front-to-back and left-to-right.

**If this is a counter-top installation, the griddle must be set and leveled using the adjusters on the legs before installing the (4) rubber foot tips provided with the griddle.** The installation of the 4 rubber tips will keep the griddle from sliding on the counter-top under normal use.

If your griddle is attached to an AccuTemp stand with casters, ensure that the floor surface is level and place the two locking casters to the "on" position.

## STAND INSTALLATION

All griddle installations utilizing an AccuTemp stand with casters, shall be made with a connector that complies with the ***Standard for Connectors for Movable Gas Appliances, ANSI Z21.69 or CAN/CGA 6.16*** and a quick disconnect device that complies with the ***Standard for Quick Disconnect Devices for Use With Gas Fuel, ANSI Z21.41 or CAN 1-6.9.***



# INSTALLATION (cont.)

---

---

## ELECTRICAL REQUIREMENTS

The electrical voltage requirement is listed on the data plate that is located on the front control panel. All standard AccuTemp gas griddles are supplied with power cord and plug that must be connected to a standard 15 A (120 V) or 20 A (208 – 240 V) grounded receptacle. Make sure that the voltage at your supply receptacle is within  $\pm 10\%$  of the voltage listed on the griddle data plate. Connection to any other voltage not identified on the data plate may cause damage to components in the griddle and damage of this type is not covered under the warranty.

Ensure that the position of the wall receptacle is not in a high heat zone. Electrical connections made in a high heat zone, such as just above, below or beside the griddle exhaust flue, will cause plug and cord failures that will not be covered under the warranty. It is recommended that the wall receptacle be positioned as low as State and local codes will allow.

## GROUNDING INSTRUCTIONS

Grounding provides a path for electric current to reduce the risk of shock. This product is equipped with a power cord having a grounding conductor and a grounding plug. The plug must be plugged into a receptacle that is properly installed and grounded in accordance with all National, State and local electrical codes, or in the absence of local electrical codes with ***National Electric Code, ANSI/NFPA 70, or the Canadian Code, CSA C22.2*** as applicable. Under no circumstances shall the plug's round grounding prong be cut or bent to fit a receptacle other than the one specified. A two-prong adaptor must never be used.

### WARNING

**This appliance must be properly grounded, in accordance with all National, State and local electrical codes.**



# INSTALLATION

---

## GAS CONNECTION

This griddle has been manufactured for use with the type of gas indicated on the data plate. Contact AccuTemp Products Technical & Customer Support Department if your gas supply does not match the gas indicated on the griddle data plate.

All gas connectors must be in accordance with local codes and must comply with the latest edition of the ***National Fuel Federal Gas Codes, ANSI Z223.1***.

This griddle should have a separate gas shutoff valve (not supplied) installed in the gas supply line. Use a 1/2" or larger diameter gas supply line to connect this griddle to the facility supply manifold to ensure a sufficient volume of gas. The facility supply regulator and manifold must be sized according to the load of all appliances connected to it. If other gas appliances are connected to the supply manifold, their gas load must be added to the calculations for properly sizing the supply manifold and regulator.

Note: Flexible residential appliance connection hoses are not suitable for this appliance and may void the warranty.

If your griddle installation location is at an altitude of 4000 feet or higher, the orifices must be changed to allow appropriate gas supply to the burners. An altitude chart for natural and propane gases is located after the Service and Troubleshooting section of this manual. Please contact the AccuTemp Technical & Customer Support Department for assistance if the orifices need to be changed due to altitude.

This griddle has been supplied with internal gas regulators that have been factory set for the gas type and pressures listed on the griddle data plate. An external regulator should not be used unless the supply gas pressure is more than 0.5 psig. The external regulator must be rated at least 125% of the griddle BTUH rate at the pressure higher than the rated regulated pressure (for example, a 36" gas griddle is rated at 70,000 BTUH at 5" W.C. for natural gas).

# INSTALLATION (cont.)

AccuTemp Accu-Steam Gas Griddle		
FACTORY STD ORIFICE SIZES	NATURAL GAS	PROPANE GAS
<b>MAIN BURNERS</b>		
24" MODELS	46	54
36" MODELS	38	51
48" MODELS	40	52
<b>PILOT BURNERS</b>		
ALL MODELS	59	71
<b>MAIN REGULATOR PRESSURES</b>		
	5" W.C.	10" W.C.
<b>PILOT REGULATOR PRESSURES</b>		
	3.5" W.C.	8" W.C.

FOR USE ONLY WITH ACCUTEMP PRODUCTS INC. APPROVED LEGS OR STANDS. THIS APPLIANCE CAN BE USED FOR NATURAL GAS AND PROPANE GAS. THIS UNIT HAS BEEN SHIPPED FROM THE FACTORY ADJUSTED FOR USE WITH THE GAS TYPE LISTED ON THE APPLIANCE DATA TAG. FOR YOUR SAFETY, REFER TO THE APPLIANCE INSTALLATION INSTRUCTIONS FOR CONVERSION PROCEDURES. AT2L-2014

**Figure 2**

Adjust the regulator(s) as needed to comply with the pressures indicated on the griddle orifice and pressure specification label. See Figure 2 for the orifice and pressure specification data.

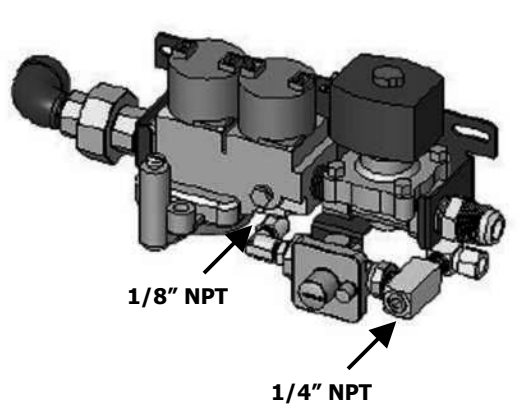

**Figure 3**

The system gas supply pressures for the main and pilot burners should be verified with a manometer while the appliance is operating in a maximum load condition. A 1/8" NPT tap is provided in the front of the main regulator valve, to measure the main burner supply pressure. A second 1/4" NPT tap is located just to the right of the pilot burner regulator for measurement of the pilot burner supply pressure. See Figure 3 for the pressure tap locations. Use a pipe joint compound or sealant designed for use with liquid petroleum gas when replacing the 1/8" NPT plug or the 1/4" NPT plug.

NOTE: Do not use an excessive amount of sealant, in order to prevent potential obstruction of orifices and control valves.

## **INSTALLATION (cont.)**

---

A colored sheet copy of the **ACCU-STEAM™** Griddle Start-Up Form and the griddle Product Registration Form were enclosed in the gas griddle from the factory. Both of these documents must be completed and submitted to the AccuTemp Technical & Customer Support Department for the warranty to be activated. The **ACCU-STEAM™** Griddle Start-Up Form can be faxed or mailed to AccuTemp. The Product Registration Form must be mailed to AccuTemp. A copy of the **ACCU-STEAM™** Griddle Start-Up Form is attached at the end of this manual for reference or use as the master form to be completed during installation and later submitted to AccuTemp. It is recommended that a copy of the completed **ACCU-STEAM™** Griddle Start-Up Form be attached to this manual for future reference.

If any of these installation requirements are not completely understood or you are unsure as to whether your supply receptacle is the correct voltage, type or is properly grounded or that you have the correct gas type and/or delivery pressure, call AccuTemp Technical & Customer Support Department at 1-800-480-0415 or +1-260-469-0415, 7:00am – 7:00pm Monday thru Sunday, before attempting to start the griddle.

# OPERATION

---

## SEASONING

It is recommended that you clean your **ACCU-STEAM™** griddle thoroughly before turning your unit on. To clean the griddle surface, just simply wash the cooking surface down with a solution of mild soap and water, and then rinse thoroughly with clean water.

Once the cooking surface has been cleaned, set the thermostat to 200°F (93°C), turn the griddle power switch to the "On" position and allow the griddle cooking surface to heat for 10 minutes. **Using a high temperature oil, such as *Pan and Grill Shortening™*, *Whirl™* or equivalent, pour enough to cover the entire griddle surface. Do not use standard vegetable oil to season the griddle cooking surface.** It may cause food to stick and result in improperly cooked food. Work this seasoning oil into the griddle surface with a regular heavy-duty scrub pad for about 5 minutes, making sure that you scrub the seasoning oil over the entire griddle-cooking surface. After the entire griddle surface has been scrubbed with seasoning oil for 5 minutes, simply wipe or squeegee off excess oil from griddle surface. Your griddle is now ready to use!



**If you use chemicals to clean your griddle periodically or on a schedule, you may need to repeat this process after the use of chemicals.**



## PREHEATING

Turn On switch to the "On" position and set the thermostat to the desired temperature. The griddle will increase its surface temperature at an average rate of 15° F (8°C) per minute. It takes approximately 22 minutes to raise the griddle from room temperature to its maximum temperature of 400° F (204°C). The griddle will be preheated when the "Heat" light starts to cycle on and off. **Please use caution as temperatures on and around the griddle cooking surface could cause severe burns.**



## COOKING

Begin cooking only after the griddle has been preheated to the desired temperature. Please note these facts:

- You can cook all the way to the edges of the griddle surface because the temperature does not vary across the entire cooking surface.
- You can turn the product to the same spot because the griddle has near instant heat recovery.
- It will always cook the same, regardless of product load or surface coverage.

### Accurate Cooking Temperatures

Because of the inaccurate surface temperatures and long recovery times common with other griddles. It is doubtful you were cooking at the set temperature or the temperature you wanted. Adjust the temperature on your **ACCU-STEAM™** griddle and it



## OPERATION (cont.)

---

---

won't change or vary by the location on the griddle surface. There are no hot or cold zones.



### Heat Lamp

**It is normal for the heat light to cycle on and off.** This light indicates when the main burners are energized. You will soon notice how little they are energized to maintain perfect surface temperatures on your griddle.

### Grease Pan

Use caution when emptying the grease pan. The contents in this pan could cause severe burns. The pan should be checked periodically and emptied as necessary to prevent an overflow or dangerous condition.

## CAUTION



**The grease can contents could cause severe burns. Slowly remove the grease can from the griddle to avoid spilling the contents.**

### DAILY CLEANING

Cleaning during the work shift can be performed with a sharp scraper. When heavy cleaning at the end of a shift or periodically as needed, the following is recommended:



- **Turn the griddle off and allow it to cool to between 220°F and 240°F (104°F and 116°C).** Use water, ice and/or griddle cleaner as needed. For example, the 3M Scotch-Brite™ Quick Clean Griddle System or Ecolab Grease Express™ High-Temp Grill Cleaner System are commercially-available products for cleaning griddles. Clean-up is very easy using these products with the quick clean liquid, water, ice or combinations of these liquids.
- **If a griddle with grease on the cooking surface is cleaned at a high temperature using water or ice, the grease may splatter and cause skin burns. Be very cautious!**
- **Do not use a griddle stone or brick to clean the griddle.**
- **Do not use a water-jet to clean the griddle.**
- **Dry all surfaces.**



## NOTE

**Never leave a chlorine sanitizer in contact with the stainless steel longer than 10 minutes. Longer contact can cause corrosion and permanently damage the griddle.**

# SERVICE AND TROUBLESHOOTING

---

---

## NOTE

**An AccuTemp Products, Inc. Technical & Customer Support Technician is available Monday thru Sunday, 7:00am to 7:00pm EST at 1-800-480-0415 or +1-260-469-3040.**

## NO USER-SERVICEABLE PARTS

There are no user-serviceable parts. AccuTemp-authorized service personnel should complete any servicing. Service performed by unauthorized personnel will void the warranty.

## WARNING



**There are no user-serviceable parts. To prevent electrical shock do not open access panel covers.**

## WARNING

**Only qualified service technicians/electricians should perform the installation to ensure that all electrical and safety requirements are met and that all wiring is performed in accordance with all national, state and local electrical codes.**

## WARNING



**Any in-field modification made without written authorization from AccuTemp will void the warranty.**

## DANGER



**Any in-field modifications that bypass the built-safety features of this product will result in death or serious injury.**

# SERVICE AND TROUBLESHOOTING (cont.)

---

---

## WARNING



**This appliance must be properly grounded, in accordance with all National, State and local electrical codes.**

## NOTE



**Service must only be performed by AccuTemp Products, Inc. authorized service personnel. Service performed by unauthorized personnel will void the warranty.**

## WARNING



**Use of any replacement parts other than those supplied by AccuTemp Products, Inc. can cause injury to the operator or damage the appliance and voids all warranties.**

## GENERAL SERVICE INFORMATION

### BASIC TROUBLESHOOTING

#### Griddle will not turn on

- Make sure the griddle is plugged in and the "ON/OFF" switch is in the ON position.
- The power indicator light must be "On" when the "ON/OFF" switch is in the "ON" position.
- Check for a facility circuit breaker (or fuse) supplying the unit.
- Check to see that the external gas shutoff valve is open.
- Call the AccuTemp Products, Inc Technical & Customer Support Department at +1-260-469-3040 or toll free at 1-800-480-0415.

# SERVICE AND TROUBLESHOOTING (cont.)

---

---

## Heat light will not come on

- Make sure the griddle is not hotter than the temperature you have it set for. If you have turned down the temperature of the griddle, the heat light will not come on again until the cooking surface drops below the temperature you have set.
- See if the heat light is coming on intermittently. While operating in a normal condition, the heat light cycles on and off periodically when at temperature.
- Call the AccuTemp Products, Inc Technical & Customer Support Department at +1-260-469-3040 or toll free at 1-800-480-0415.

## Uneven or inaccurate surface temperatures



- Verify the surface temperature with an accurate surface probe thermometer. **Use of an infrared thermometer will not give an accurate reading of the griddle surface temperatures.**
- Call the AccuTemp Products, Inc Technical & Customer Support Department at +1-260-469-3040 or toll free at 1-800-480-0415.

## Unit will not turn off

- This indicates a serious control malfunction.
- Turn off the griddle's electrical supply at the source.
- Call the AccuTemp Products, Inc Technical & Customer Support Department at +1-260-469-3040 or toll free at 1-800-480-0415.

## NOTE

**An AccuTemp Products, Inc. Technical & Customer Support Technician is available Monday thru Sunday, 7:00am to 7:00pm EST.  
+1-260-469-3040 or 1-800-480-0415**

### REGULATOR SET PRESSURES

PART No	MAIN GAS REGULATOR	PILOT GAS REGULATOR	GRIDDLE SIZE / CONVERSION TO GAS TYPE
AT0H-3035-1	11 In H2O	8 In H2O	24" PROPANE GAS KIT
AT0H-3035-2	11 In H2O	8 In H2O	36" PROPANE GAS KIT
AT0H-3035-3	11 In H2O	8 In H2O	48" PROPANE GAS KIT
AT0H-3035-4	5 In H2O	3.5 In H2O	24" NATURAL GAS KIT
AT0H-3035-5	5 In H2O	3.5 In H2O	36" NATURAL GAS KIT
AT0H-3035-6	5 In H2O	3.5 In H2O	48" NATURAL GAS KIT

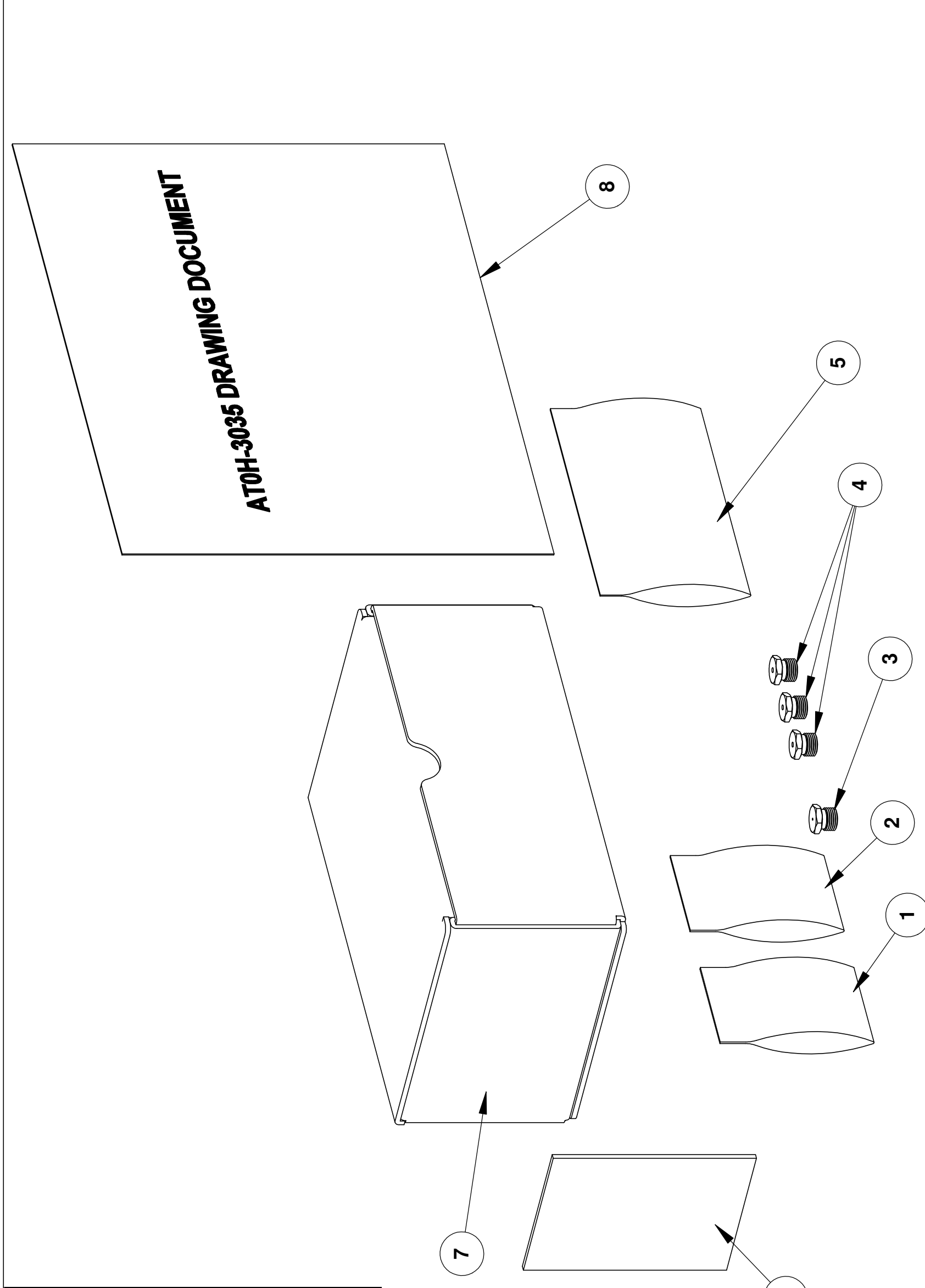

QTY	AT0H-3035-1	QTY	AT0H-3035-2	QTY	AT0H-3035-3	QTY	AT0H-3035-4	QTY	AT0H-3035-5	QTY	AT0H-3035-6	PART NO.	ITEM NO.	DESCRIPTION
1	1	1	1	1	1	1	1	1	1	1	1	AT0H-3035	8	GAS APPLIANCE STD CONVERSION KIT DWG
1	1	1	1	1	1	1	1	1	1	1	1	AT0S-2780-1	7	CARDBOARD BOX
1	1	1	1	1	1	1	1	1	1	1	1	AT0S-2770-1	6	FOAM OR BUBBLE WRAP
1	1	1	1	1	1	1	1	1	1	1	1	AT0H-2782-1	5	ZIPLOC BAG
2	-	-	-	-	-	-	-	-	-	-	-	AT0B-2888-54	4	ORIFICE
-	-	3	-	-	-	-	-	-	-	-	-	AT0B-2888-52	4	ORIFICE
-	-	2	-	-	-	-	-	-	-	-	-	AT0B-2888-51	4	ORIFICE
-	-	-	-	2	-	-	-	-	-	-	-	AT0B-2888-46	4	ORIFICE
-	-	-	-	-	-	-	-	-	-	3	-	AT0B-2888-40	4	ORIFICE
-	-	-	-	-	-	-	-	2	-	-	-	AT0B-2888-38	4	ORIFICE
-	-	-	-	1	-	-	-	1	-	1	-	AT0B-2888-59	3	ORIFICE
1	1	1	1	-	-	-	-	-	-	-	-	AT0B-2888-71	3	ORIFICE
-	-	-	-	-	-	-	1	1	-	-	-	AT0H-3034-4	2	(PILOT) REGULATOR SPRING KIT
1	1	1	1	-	-	-	-	-	-	-	-	AT0H-3034-2	2	(PILOT) REGULATOR SPRING KIT
-	-	-	-	1	-	-	1	1	-	-	-	AT0H-3034-3	1	(MAIN) REGULATOR SPRING KIT
1	1	1	1	-	-	-	-	-	-	-	-	AT0H-3034-1	1	(MAIN) REGULATOR SPRING KIT
QTY	AT0H-3035-1	QTY	AT0H-3035-2	QTY	AT0H-3035-3	QTY	AT0H-3035-4	QTY	AT0H-3035-5	QTY	AT0H-3035-6			

REVISIONS			REVISIONS		
ECN/REV	DESCRIPTION	DATE	APPR	DESCRIPTION	DATE

Unless otherwise specified,  
Dimensions: Inches  
Bends: 90°  
Tolerances:  
Angular: ±1°  
2 Place Decimal ±.02  
3 Place Decimal ±.005  
I.I.R. ±.005  
1/25 Micro Inches  
GD&T Per ANSI Y14.5M  
Comments:  
Do Not Scale Drawing

Drawn	G. SEITZ	Date	1/03/04
Checked	D. STANLEY	Project Eng	G. SEITZ
Title:		1/13/05	

AccuTemp Products, Inc.  
8415 N. Clinton Park  
Fort Wayne, IN 46825

**AccuTemp**

**GAS APPLIANCE STD CONVERSION KIT**

Size: Drawing No.: **C AT0H-3035** Rev: -  
Scale: 1:2 EDR: 080 Sheet 1 of 1

## GAS GRIDDLE ORIFICE REFERENCE TABLE FOR ALITITUDE AND BTU CONTENT

**NOTE:** This Table represents the standard upper and lower ranges of BTU per cubic foot content. There is no relationship between the natural gas BTU content and the propane BTU content as shown in each section of this Table.

HEAT VALUE BTU/CU FT. (NATURAL GAS - 990, PROPANE GAS - 2200)								
	PILOT BURNER		24" GRIDDLE MAIN		36" GRIDDLE MAIN		48" GRIDDLE MAIN	
Altitude ft	NG	LP	NG	LP	NG	LP	NG	LP
0 - 3,999	#57	#71	#46	#54	#38	#51	#40	#52
4,000 -	#59	#71	#46	#54	#41	#51	#43	#52
5,000 -	#60	#71	#49	#55	#42	#52	#43	#52
6,000 -	#61	#71	#49	#55	#42	#52	#44	#53
7,000 -	#62	#71	#50	#55	#43	#52	#45	#53
8,000 -	#63	#72	#51	#55	#44	#52	#45	#54
9,000 -	#64	#73	#51	3/64	#45	#54	#47	#54
10,000 +	#65	#74	#52	#56	#46	#54	#48	#55
HEAT VALUE BTU/CU FT. (NATURAL GAS - 1000, PROPANE GAS - 2300)								
Altitude ft	NG	LP	NG	LP	NG	LP	NG	LP
0 - 3,999	#59	#70	#46	#54	#38	#51	#40	#52
4,000 -	#59	#70	#46	#55	#38	#52	#40	#52
5,000 -	#60	#70	#49	#55	#43	#52	#43	#53
6,000 -	#61	#71	#49	#55	#43	#52	#44	#53
7,000 -	#62	#72	#50	#55	#44	#53	#45	#53
8,000 -	#63	#73	#51	3/64	#44	#53	#45	#53
9,000 -	#64	#73	#51	#56	#45	#53	#47	#54
10,000 +	#65	#74	#52	#57	#46	#54	#48	#55
HEAT VALUE BTU/CU FT. (NATURAL GAS - 1100, PROPANE GAS - 2400)								
Altitude ft	NG	LP	NG	LP	NG	LP	NG	LP
0 - 3,999	#59	#70	#48	#54	#42	#51	#42	#52
4,000 -	#61	#70	#49	#55	#42	#52	#44	#52
5,000 -	#62	#71	#50	#55	#43	#52	#45	#53
6,000 -	#63	#72	#50	#55	#44	#53	#45	#53
7,000 -	#64	#72	#51	3/64	#45	#53	#46	#54
8,000 -	#65	#73	#52	#56	#45	#53	#47	#54
9,000 -	#66	#74	#52	#57	#47	#54	#48	#54
10,000 +	#66	#74	#52	#57	#48	#55	#49	#55
HEAT VALUE BTU/CU FT. (NATURAL GAS - 1200, PROPANE GAS - 2500)								
Altitude ft	NG	LP	NG	LP	NG	LP	NG	LP
0 - 3,999	#61	#71	#49	#54	#43	#51	#44	#52
4,000 -	#63	#71	#50	#54	#44	#51	#44	#52
5,000 -	#64	#72	#51	3/64	#44	#53	#45	#53
6,000 -	#64	#72	#51	3/64	#45	#53	#47	#55
7,000 -	#65	#72	#52	3/64	#46	#54	#48	#55
8,000 -	#66	#72	#52	#57	#48	#54	#49	#55
9,000 -	#66	#72	#53	#57	#48	#54	#49	#55
10,000 +	#67	#72	#53	#57	#49	#55	#50	3/64
HEAT VALUE BTU/CU FT. (NATURAL GAS - 1300, PROPANE GAS - 2700)								
Altitude ft	NG	LP	NG	LP	NG	LP	NG	LP
0 - 3,999	#62	#71	#50	#55	#44	#52	#45	#53
4,000 -	#64	#72	#51	3/64	#45	#53	#47	#53
5,000 -	#65	#73	#51	3/64	#45	#53	#48	#54
6,000 -	#66	#73	#52	#56	#47	#53	#48	#54
7,000 -	#66	#74	#53	#56	#48	#54	#49	#54
8,000 -	#67	#74	#53	#57	#48	#54	#50	#55
9,000 -	#68	#74	#53	#58	#49	#55	#50	#55
10,000 +	#69	#75	#54	#59	#50	#55	#51	3/64



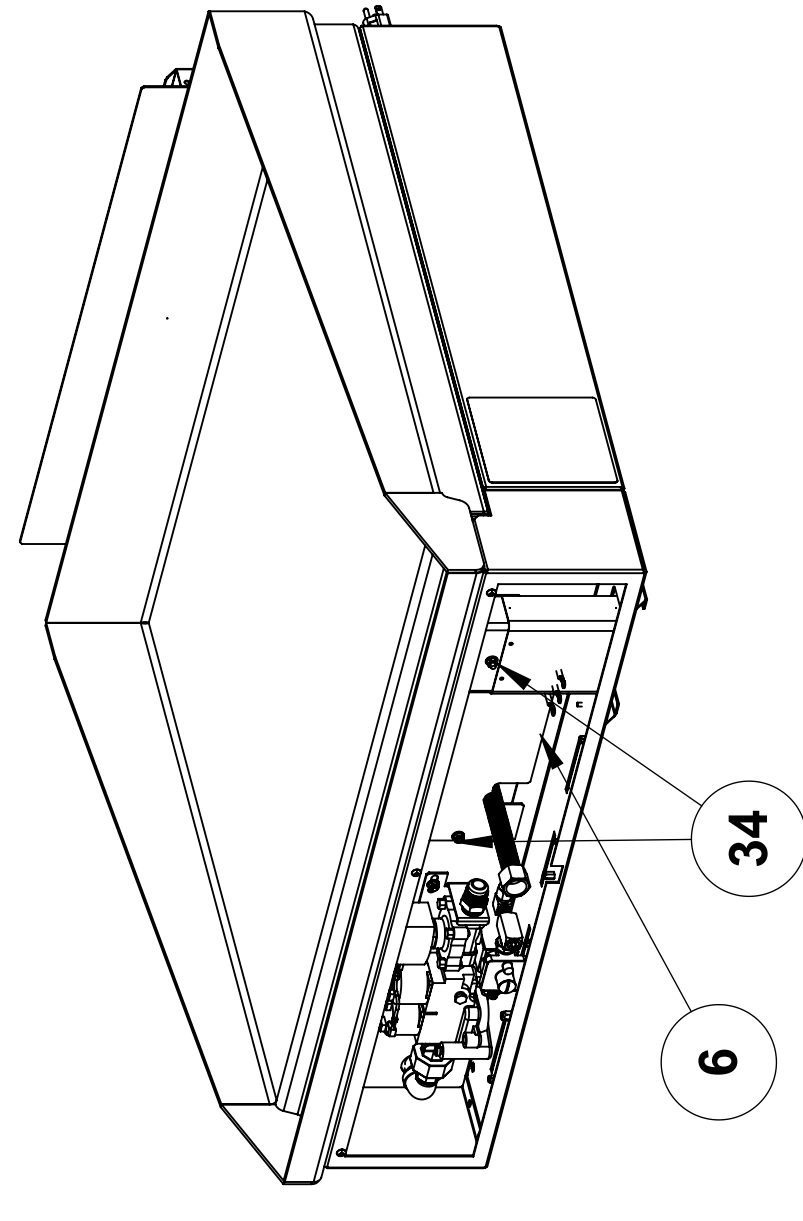

CONTROL PANEL & GASKET  
NOT SHOWN  
©

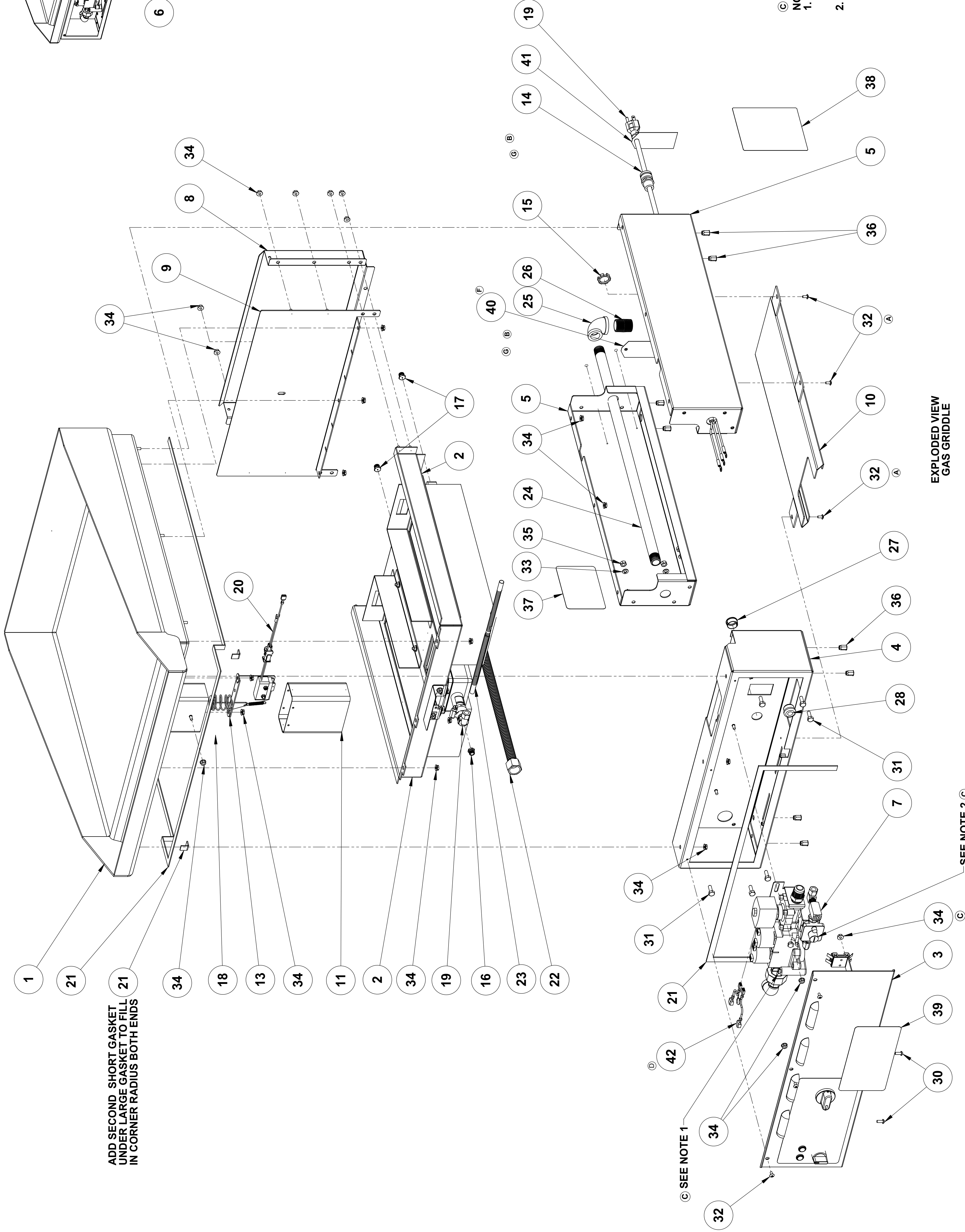

ADD SECOND SHORT GASKET UNDER LARGE GASKET TO FILL IN CORNER RADIUS BOTH ENDS

© SEE NOTE 1

© SEE NOTE 2

- © NOTES
1. ADJUST MAIN GAS REGULATOR CONTROL VALVE TO 5" W.C. FOR NATURAL GAS, 10" W.C. FOR PROPANE LOCATED IN ITEM #7
  2. ADJUST PILOT REGULATOR TO 3.5" W.C. FOR NATURAL GAS, 8" W.C. FOR PROPANE LOCATED IN ITEM #7

Accutemp Products, Inc. 8415 N. Clinton Park Fort Wayne, IN 46825		Name	Date
Drawn	ALB	05-05-04	
Checked	GLS	05-05-04	
Project Eng	GLS	05-05-04	
Material	N/A		
Angular	±1°		
2 Place Decimal	±.02		
1 Place Decimal	±.005		
Tolerance	±.005		
GD&T Per ANSI Y14.5M			
Comments:			
Finish:	N/A		
Do Not Scale Drawing			

EXPLODED VIEW  
GAS GRIDDLE

GAS GRIDDLE ASSY

Size: Drawing No.: AT2A-2813 Rev: G  
Scale: 1:4 EDR: 062 Sheet 2 of 2



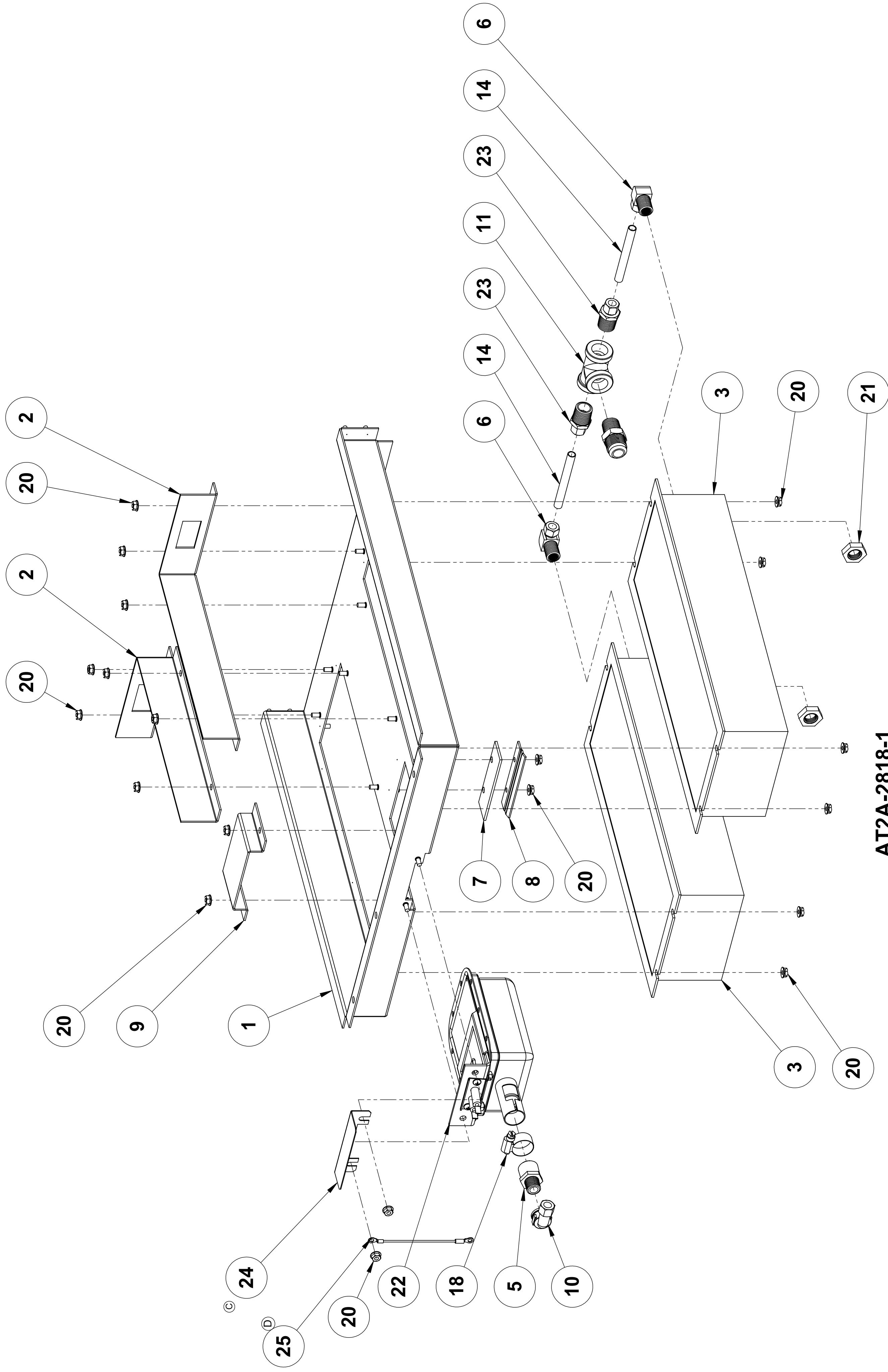

**AT2A-2818-1  
COMBUSTION CHAMBER 24"**

QTY	AT2A-2818-3	QTY	AT2A-2818-2	QTY	AT2A-2818-1	PART NO.	ITEM	DESCRIPTION
1	1	1	1	1	1	AT0A-3506-1	25	GROUNDING HARNESS ASSEMBLY
1	1	1	1	1	1	AT2M-3299-1	24	SHIELD, WIRE HEAT
2	2	2	2	2	2	AT0P-2097-2	23	COMPRESSION FITTING
1	1	1	1	1	1	AT2A-2255-2	22	PILOT BURNER ASSY
3	2	2	2	2	2	AT0F-2909-1	21	NPT PIPE LOCKNUT
32	26	22	22	22	22	AT0F-1017-41002	20	NUT, #10-24UNC HEX SERRATED
							19	
							18	HOSE CLAMP
1	1	1	1	1	1	AT0F-2908-1	18	HOSE CLAMP
1	-	-	-	-	-	AT2P-2105	17	18.5" LONG 3/8 FLEXTUBE COMP ENDS
1	1	1	1	1	1	AT0P-2096-1	16	ELBOW 90° COMPRESSION
2	2	2	2	2	2	AT2M-2824-1	15	BARRIER, FLU GAS - SHORT
-	-	-	-	-	-	AT0P-2276-1	14	SEAMLESS TUBING
2	2	2	2	2	2	AT0P-2276-2	14	SEAMLESS TUBING
1	1	1	1	1	1	AT0P-2845-1	13	MALE ADAPTER, 5/8" OD FLARE X 1/2 NPT X 3/8 NPT
1	-	-	-	-	-	AT0P-2844-1	12	CROSS, 1/2 NPT SCH 40
-	1	1	1	1	1	AT0P-2090-1	11	TEE 1/2 NPT SCH 40
1	1	1	1	1	1	AT0P-2094-1	10	ELBOW 90° COMPRESSION
1	1	1	1	1	1	AT2M-2881-1	9	DEFLECTOR, GAS GRIDDLE
1	1	1	1	1	1	AT2M-2792-1	8	BRKT, STEP
1	1	1	1	1	1	AT2M-2791-1	7	SPACER, BURNER
3	2	2	2	2	2	AT0B-2891-1	6	ELBOW 90° COMPRESSION
1	1	1	1	1	1	AT0B-2890-1	5	ORIFICE, ADAPTER
3	2	2	2	2	2	AT2B-2099-1	4	30,000 BTU IR MAIN BURNER
-	-	-	-	-	-	AT2B-2131-1	3	20,000 BTU IR MAIN BURNER
-	-	-	-	-	-	AT2M-2795-4	2	BARRIER, FLUE GAS
1	-	-	-	-	-	AT2M-2795-3	2	BARRIER, FLUE GAS
1	2	2	2	2	2	AT2M-2795-2	2	BARRIER, FLUE GAS
-	-	-	-	-	-	AT2M-2795-1	2	BARRIER, FLUE GAS
1	-	-	-	-	-	AT2A-2790-3	1	COMBUSTION BOX ASSEMBLY
-	1	1	1	1	1	AT2A-2790-1	1	COMBUSTION BOX ASSEMBLY
-	1	1	1	1	1	AT2A-2790-2	1	COMBUSTION BOX ASSEMBLY

Unless otherwise specified, Dimensions: Inches  
 Bends: 90°  
 Tolerances:  
 Angular: ±1°  
 2 Place Decimal ±.02  
 3 Place Decimal ±.005  
 TIR: ±.005  
 V125 Micro Inches  
 GD&T Per ANSI Y14.5M  
 Comments:  
 Do Not Scale Drawing

Drawn	ALB	06-14-04	Name	ALB	06-14-04
Checked	GLS	06-14-04	Date	GLS	06-14-04
Project Eng	GLS	06-14-04	Title: <b>COMBUSTION CHAMBER ASSEMBLY</b>		
Material:	N/A				
Finish:	N/A				
Size:	D AT2A-2818				
Rev:	D				
Scale:	1:3 EDR: 045F				
Sheet	1 of 3				

AccuTemp Products, Inc  
 8415 N. Clinton Park  
 Fort Wayne, IN 46825

ECN	REV	DESCRIPTION	DATE	APPR	LECI/ALB	ALBI/LEC	APGLS
373	D	REMOVED: (BOM ITEM #19) WAS AT0F-1017-2909-1 TO GROUPS -1 TO GROUPS -29 WAS 18, 32 WAS 20, ADDED: ITEM #25 (AT0A-3506-1) TO GROUPS -1 TO GROUPS -29	12-14-07				
283	C	ADDED: ITEM #24 (AT2M-3299-1) TO GROUPS -1 TO GROUPS -29	06-23-06				
181	B	CHGD: ITEM #20 AT0F-2908-1, WAS AT2M-2908-1	11-29-04				
164	A	CHGD: AT0F-1017-41002 WAS 20, 32 WAS 26	06-11-04				

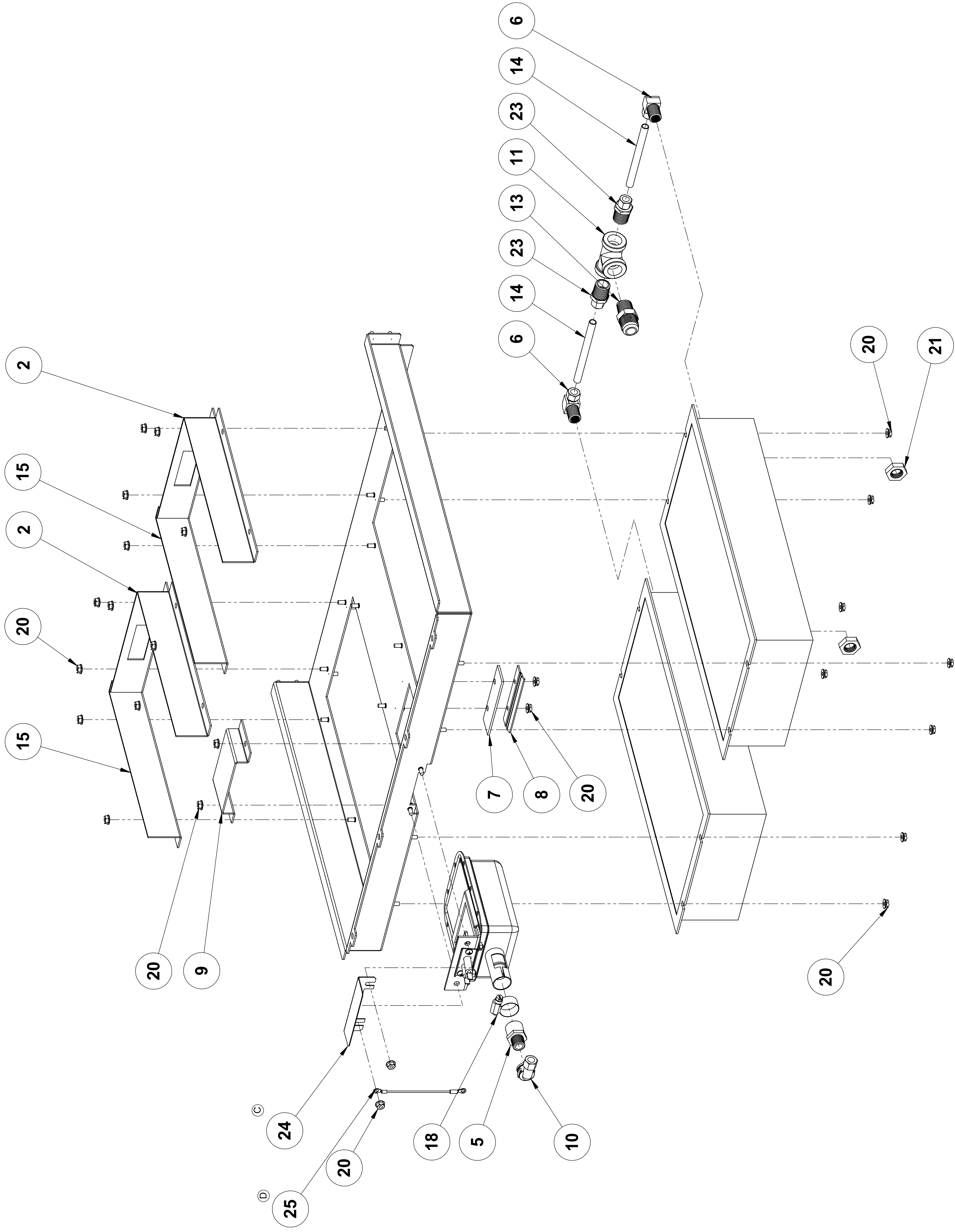

AT2A-2818-2  
COMBUSTION CHAMBER 36"

Unless otherwise specified,  
 Units: Inches  
 Fits: 90°  
 Tolerances:  
 Angular: ±1°  
 2 Place Decimal: ±.02  
 3 Place Decimal: ±.005  
 1 LR: ±.005  
 1/125 Micro Inches  
 GD&T Per ANSI Y14.5M  
 Comments:  
 Do Not Scale Drawing

AccuTemp Products, Inc 8415 N. Clinton Park Fort Wayne, IN 46825		Date	
Drawn	ALB	05-14-04	
Checked	GLS	05-14-04	
Project Eng.	GLS	05-14-04	
Material:		Title:	
N/A		COMBUSTION CHAMBER ASSEMBLY	
Finish:		Rev:	
N/A		D	
Scale: 1:1		Drawing No.: AT2A-2818	
		Sheet 2 of 3	

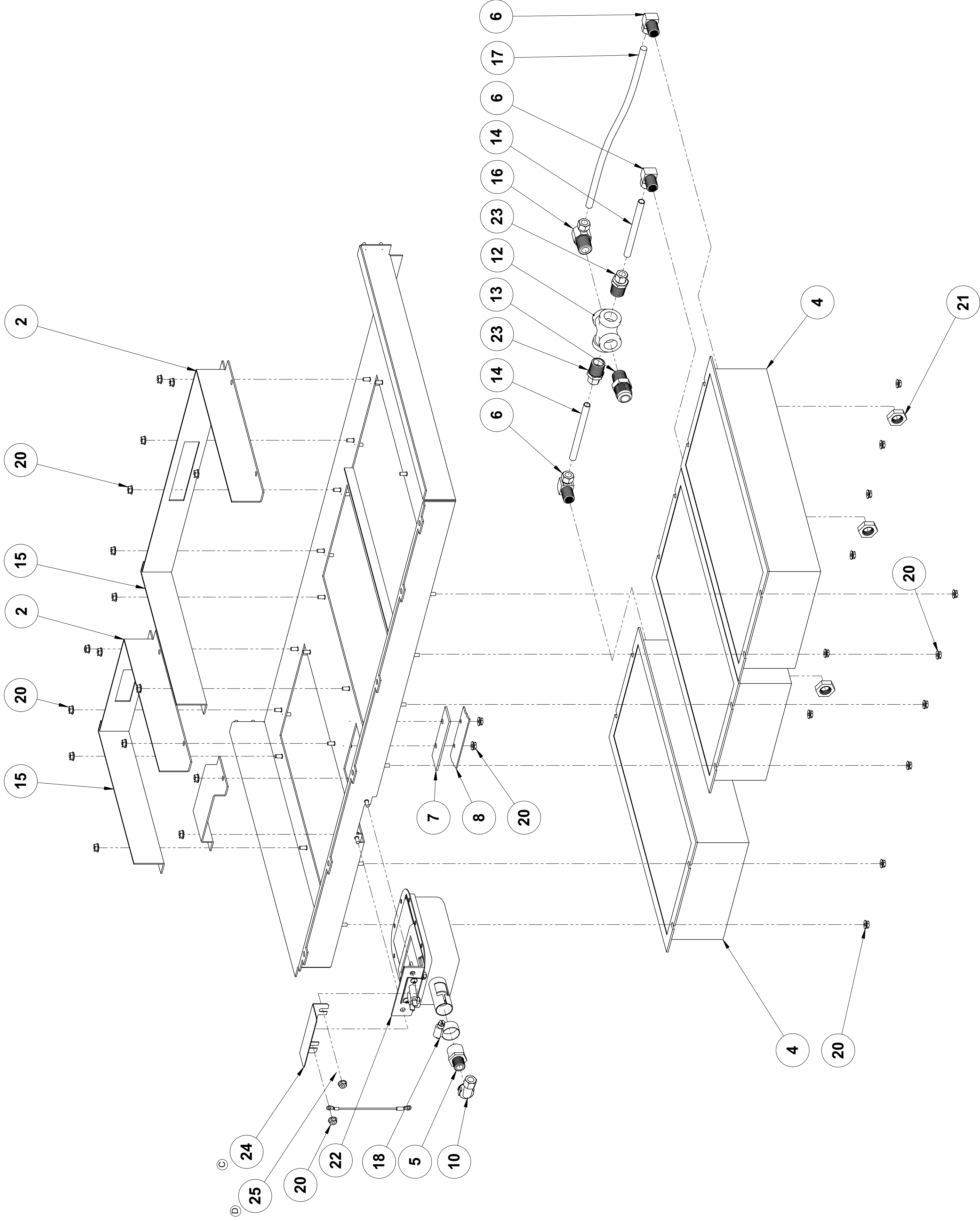

AT2A-2818-3  
COMBUSTION CHAMBER 48"

Unless otherwise specified, Dimensions: Inches Rounds: 90° Tolerances: Angular: ±1° 2 Place Decimal: ±.02 3 Place Decimal: ±.005 T.I.R.: ±.005 GD&T Per ANSI Y14.5M Comments: Do Not Scale Drawing		Name: ALB Checked: G.S. Project Eng: G.S. Material: N/A Finish: N/A	Date: 05-14-04 05-14-04 05-14-04 05-14-04	AccuTemp Products, Inc 8415 N. Clinton Park Fort Wayne, IN 46825 <b>AccuTemp</b> <b>COMBUSTION CHAMBER ASSEMBLY</b> Drawing No.: <b>AT2A-2818</b> Rev: <b>D</b> Scale: 1:3 EDR: 045F
--	--	---	--	---

**NOTES:**

- ① DIMENSION IS TAKEN FROM OUTSIDE FLANGE OF AT2A-2785-1 TO OUTSIDE FLANGE OF AT2M-2793-1

NOTE: GROUND ROD TO BE POSITIONED ONTO LOWEST POINTS OF CERAMIC SURFACE ⑥

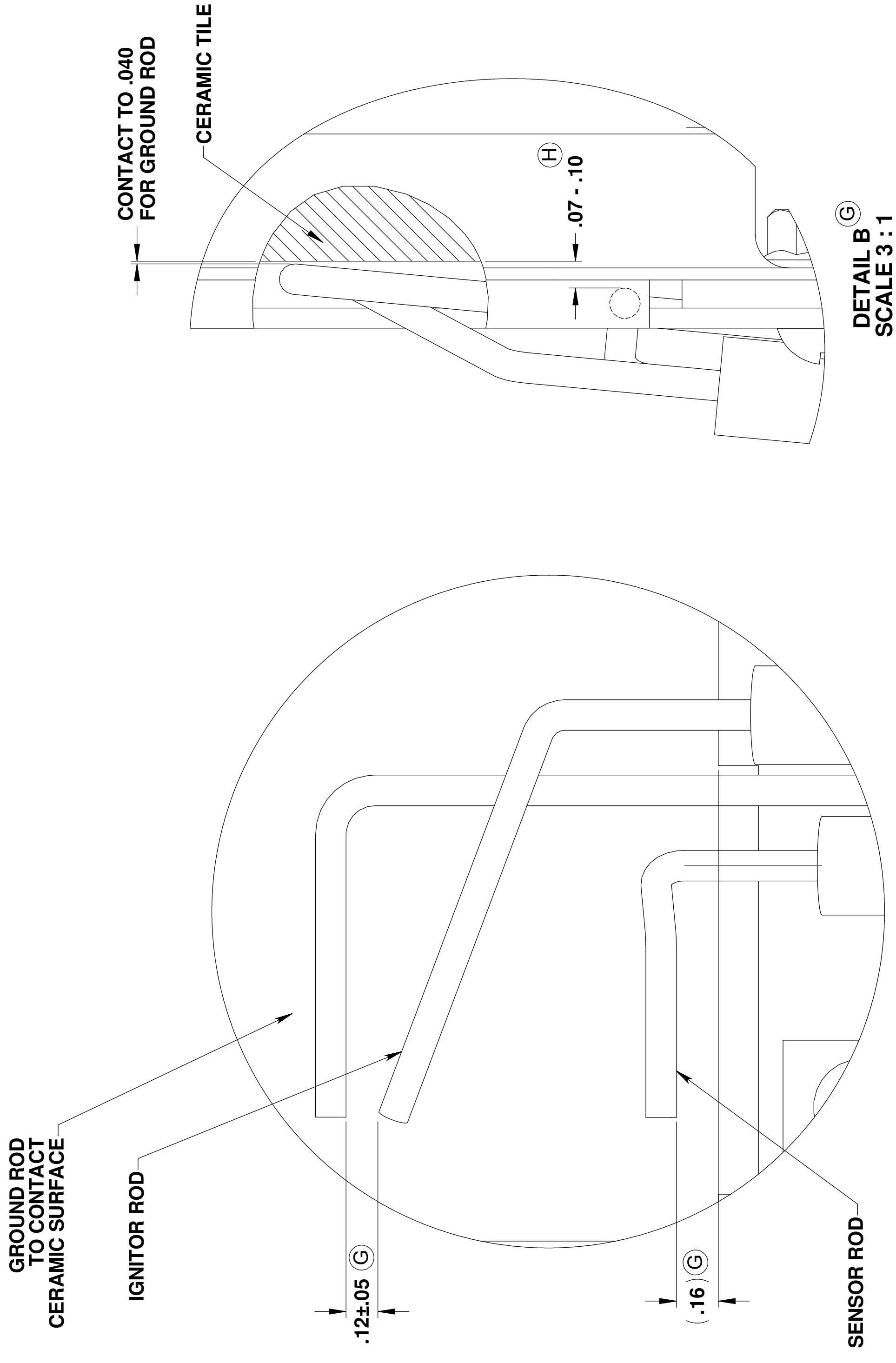

DETAIL A ③  
SCALE 3 : 1

DETAIL B ③  
SCALE 3 : 1

HOLE PATTERN CONSISTENT ACROSS ENTIRE CERAMIC TILE SURFACE ③

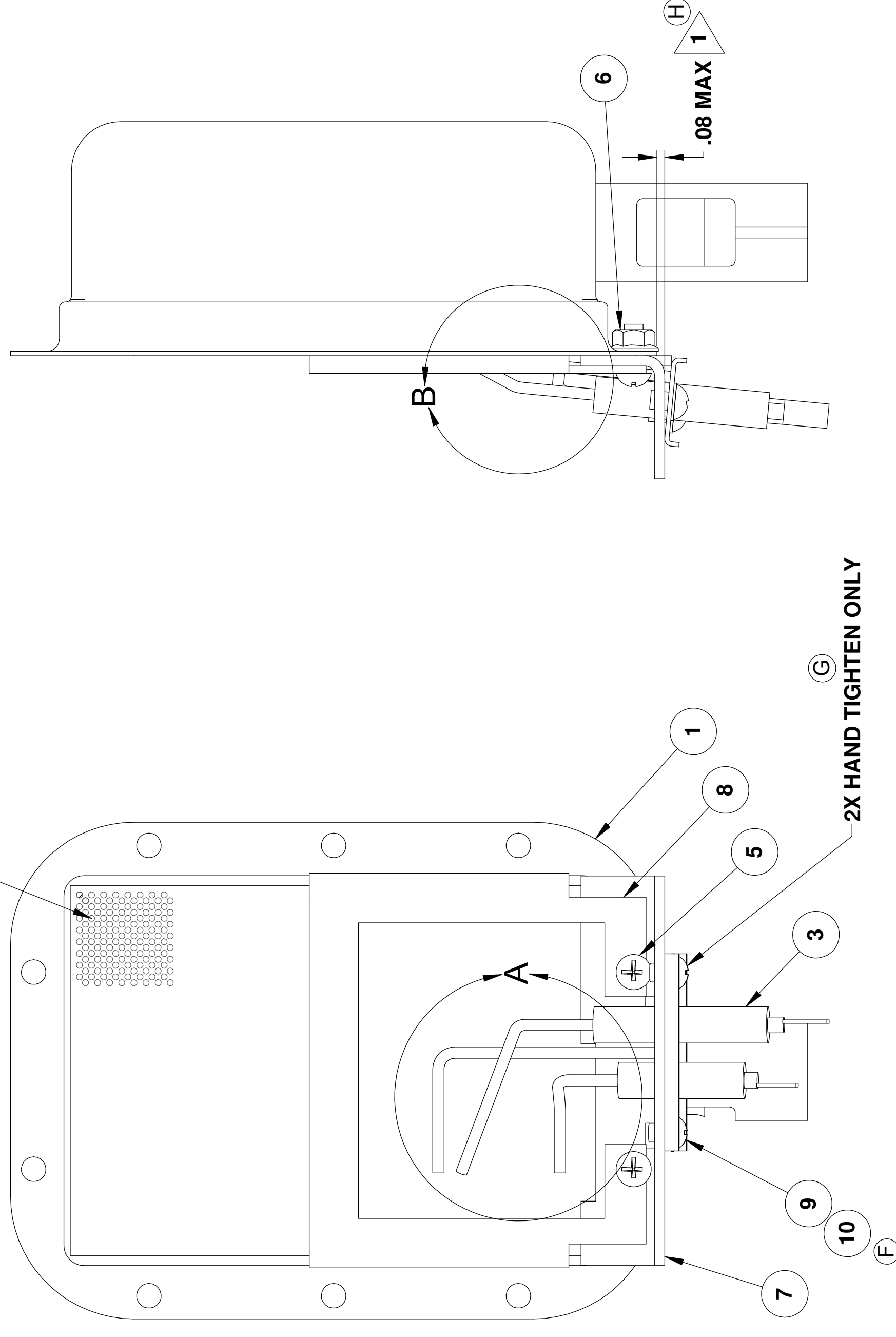

**AT2A-2255-2 ③**

**SETUP AND CALIBRATION: ③**

1. ASSEMBLE AND POSITION RODS AS SHOWN IN DETAIL "A".
2. ALLOW UNIT TO WARM UP APPROXIMATELY 20 SECONDS UNTIL THE IGNITOR STOPS SPARKING. IF THE UNIT WILL NOT STOP SPARKING OR INTERMITTANTLY SPARKS, ADJUST THE PROBES AND REPEAT THIS STEP.
- ③ 3. THE mV READING MUST BE A MINIMUM OF 40mV.
- ④ 4. IF THE READING IS LESS THAN 40mV, REPOSITION THE SENSOR ROD OVER THE ROWS OF HOLES LOCATED IN THE VALLEY OF THE CERAMIC SURFACE AND REPEAT STEP 4.
5. IF UNABLE TO ACHIEVE THE MINIMUM mV AFTER SEVERAL TRIES, REPLACE THE SENSOR/IGNITOR PROBE ASSY (ITEM 3) AND REPEAT THE SETUP AND CALIBRATION PROCEDURE.

QTY	PART NO.	ITEM NO.	DESCRIPTION
2	AT0F-2666-40000	10	WASHER, #10 INTERNAL TOOTH LOCK
2	AT0F-2755-41022	9	SCREW, #10-24UNC X 1/4 PHILIPS ROUND HEAD MACHINE
1	AT2M-2871-1	8	BRKT, GROUND PLANE
1	AT2M-2793-1	7	BRKT, BURNER & IGNTR/SNSR
2	AT0F-1017-41001	6	#10-24UNC HEX SERRATED NUT
2	AT0F-2755-41040	5	SCREW, #10-24UNC X 1/2 PHILIPS ROUND HEAD MACHINE
		4	
1	AT2E-2083-1	3	IGNITOR / SENSOR PROBE
		2	
1	AT2A-2785-1	1	PILOT BURNER/TUBE ASSY

ECN	REV	CHG'D	DESCRIPTION	DATE	APPR
299	H		CHG'D: (RH VIEW) .08 MAX WAS .06 MAX ADDED: (DETAIL B) .07-...10	09/21/06	LEC/A/TP

Drawn	Checked	Project Eng	Material	Title
ALB	GLS	GLS		

Name	Date
ALB	11/11/2003
GLS	2/17/2004
GLS	2/17/2004

Rev.	Size	Drawing No.	Rev.
D	D	AT2A-2255	H

Unless otherwise specified, Refer to: Inches	Do Not Scale Drawing
Tolerances: 2 Place Decimal ±.02 1 Place Decimal ±.005 T/R ±.005 V125 Micro Inches GD&T Per ANSI Y14.5M	

Accutemp Products, Inc.	8415 N. Clinton Park	Fort Wayne, IN 46825
<b>PILOT BURNER ASSY</b> <b>GAS GRIDDLE</b>		

**NOTES: UNLESS OTHERWISE SPECIFIED**

1. ALL PIPE THREADS TO BE SEALED WITH THREAD SEALANT OR THREAD TAPE APPROVED FOR GAS.

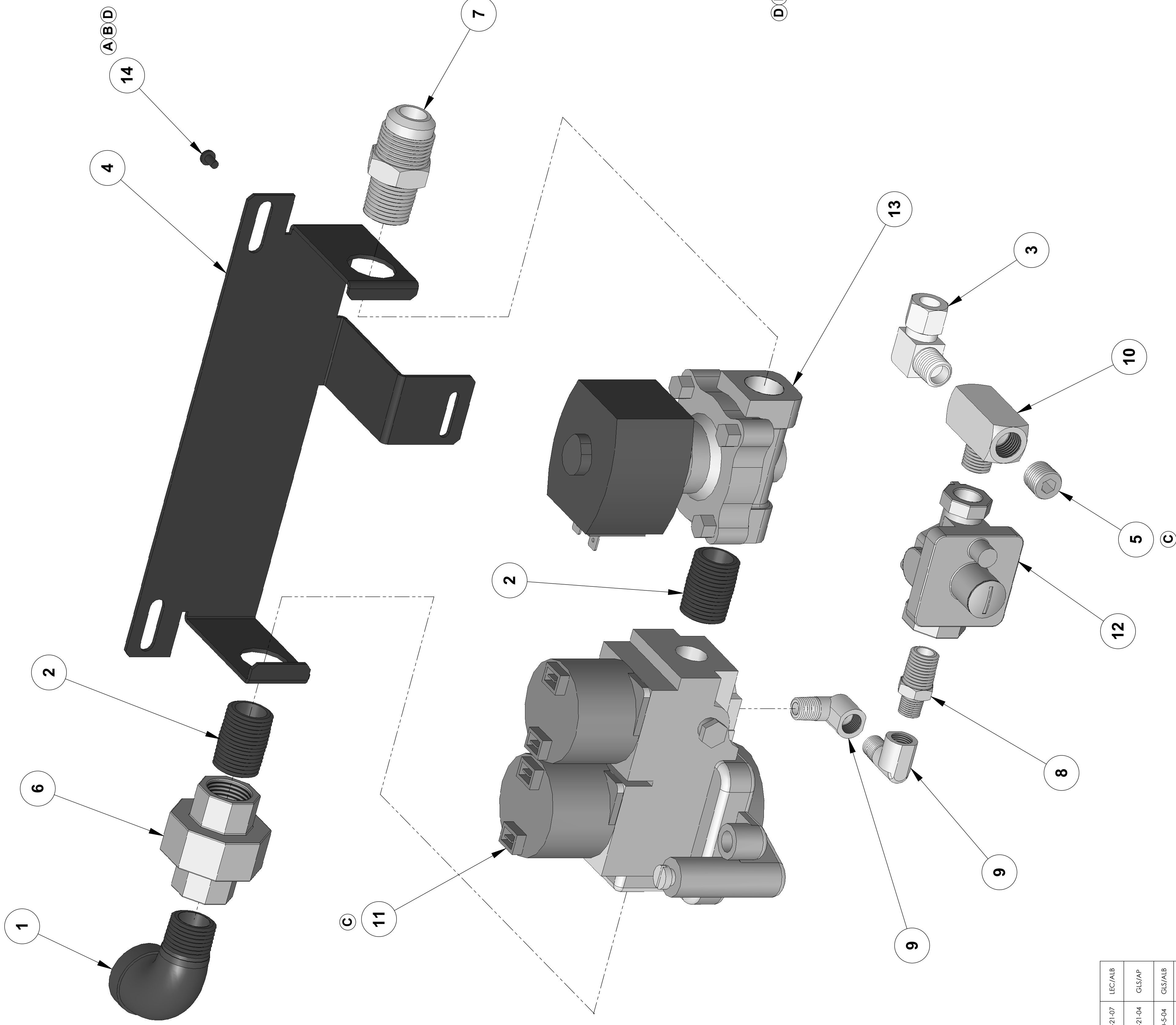

**AT2A-2850-2  
GAS CONTROL VALVE ASSEMBLY PROPANE**

**AT2A-2850-2  
GAS CONTROL VALVE ASSEMBLY PROPANE  
OTHERWISE SAME AS AT2A-2850-1**

QTY	AT2A-2850-2	QTY	AT2A-2850-1	PART NO.	DESCRIPTION
1	1	1	1	AT0F-3222-21025	14 SCREW, PHILLIPS PAN HEAD #6-32 TYPE F 1/4"
1	1	1	1	AT2E-2087-1	13 MAIN BURNER VALVE
1	-	1	1	AT0P-2847-2	12 PRESSURE REGULATOR, PROPANE GAS
-	1	1	1	AT0P-2847-1	12 PRESSURE REGULATOR, NATURAL GAS
1	-	1	1	AT2E-1806-3	11 CONTROL VALVE, GAS 10" W.C. PROPANE GAS
-	1	1	1	AT2E-1806-2	11 CONTROL VALVE, GAS 5" W.C. NATURAL GAS
1	1	1	1	AT0P-2858-1	10 TEE MALE BRANCH
2	2	2	2	AT0P-2849-3	9 STREET ELBOW 90°
1	1	1	1	AT0P-2848-1	8 REDUCING HEX NIPPLE
1	1	1	1	AT0P-2845-1	7 MALE CONNECTOR
1	1	1	1	AT0P-2843-1	6 UNION BLACK IRON PIPE
1	1	1	1	AT0P-3024-2	5 PLUG COUNTERSUNK HEX HEAD
1	1	1	1	AT2M-2838-1	4 BRKT GAS REGULATOR
1	1	1	1	AT0P-2096-2	3 ELBOW 90° COMPRESSION
2	2	2	2	AT0P-2091-4	2 CLOSE NIPPLE PIPE
1	1	1	1	AT0P-2089-4	1 ELBOW, STREET 90°

ECN	REV.	DESCRIPTION	DATE	APPROVED
344	D	CHGD: ITEM #14 AT0F-3222-21025 WAS AT0F-2773-21022	05-21-07	LEC/ALB
186	C	RMAVD: ITEM NO 6 AT0P-2841-1, CHGD: BOMBALLOON ERROR: ITEM NO 11 W/ CHGD: ITEM NO 5 AT0P-3024-2	12-21-04	GLS/AP
152	B	CHGD AT0F-2773-21022 WAS AT0F-31030	10-5-04	GLS/ALB
101	A	ADDED: ITEM 14	05-07-04	GLS

ECN	REV.	DESCRIPTION	DATE	APPROVED
101	A	ADDED: ITEM 14	05-07-04	GLS

AccuTemp Products, Inc  
8415 N. Clinton Park  
Fort Wayne, IN 46825

AccuTemp

**GAS CONTROL  
VALVE ASSEMBLY**

Drawing No.: **D**  
Size: **AT2A-2850**

Rev: **D**  
Scale: 1:1 EDR: 045E

QTY	AT2A-2850-2	QTY	AT2A-2850-1	PART NO.	DESCRIPTION
1	1	1	1	AT0F-3222-21025	14 SCREW, PHILLIPS PAN HEAD #6-32 TYPE F 1/4"
1	1	1	1	AT2E-2087-1	13 MAIN BURNER VALVE
1	-	1	1	AT0P-2847-2	12 PRESSURE REGULATOR, PROPANE GAS
-	1	1	1	AT0P-2847-1	12 PRESSURE REGULATOR, NATURAL GAS
1	-	1	1	AT2E-1806-3	11 CONTROL VALVE, GAS 10" W.C. PROPANE GAS
-	1	1	1	AT2E-1806-2	11 CONTROL VALVE, GAS 5" W.C. NATURAL GAS
1	1	1	1	AT0P-2858-1	10 TEE MALE BRANCH
2	2	2	2	AT0P-2849-3	9 STREET ELBOW 90°
1	1	1	1	AT0P-2848-1	8 REDUCING HEX NIPPLE
1	1	1	1	AT0P-2845-1	7 MALE CONNECTOR
1	1	1	1	AT0P-2843-1	6 UNION BLACK IRON PIPE
1	1	1	1	AT0P-3024-2	5 PLUG COUNTERSUNK HEX HEAD
1	1	1	1	AT2M-2838-1	4 BRKT GAS REGULATOR
1	1	1	1	AT0P-2096-2	3 ELBOW 90° COMPRESSION
2	2	2	2	AT0P-2091-4	2 CLOSE NIPPLE PIPE
1	1	1	1	AT0P-2089-4	1 ELBOW, STREET 90°

ECN	REV.	DESCRIPTION	DATE	APPROVED
344	D	CHGD: ITEM #14 AT0F-3222-21025 WAS AT0F-2773-21022	05-21-07	LEC/ALB
186	C	RMAVD: ITEM NO 6 AT0P-2841-1, CHGD: BOMBALLOON ERROR: ITEM NO 11 W/ CHGD: ITEM NO 5 AT0P-3024-2	12-21-04	GLS/AP
152	B	CHGD AT0F-2773-21022 WAS AT0F-31030	10-5-04	GLS/ALB
101	A	ADDED: ITEM 14	05-07-04	GLS



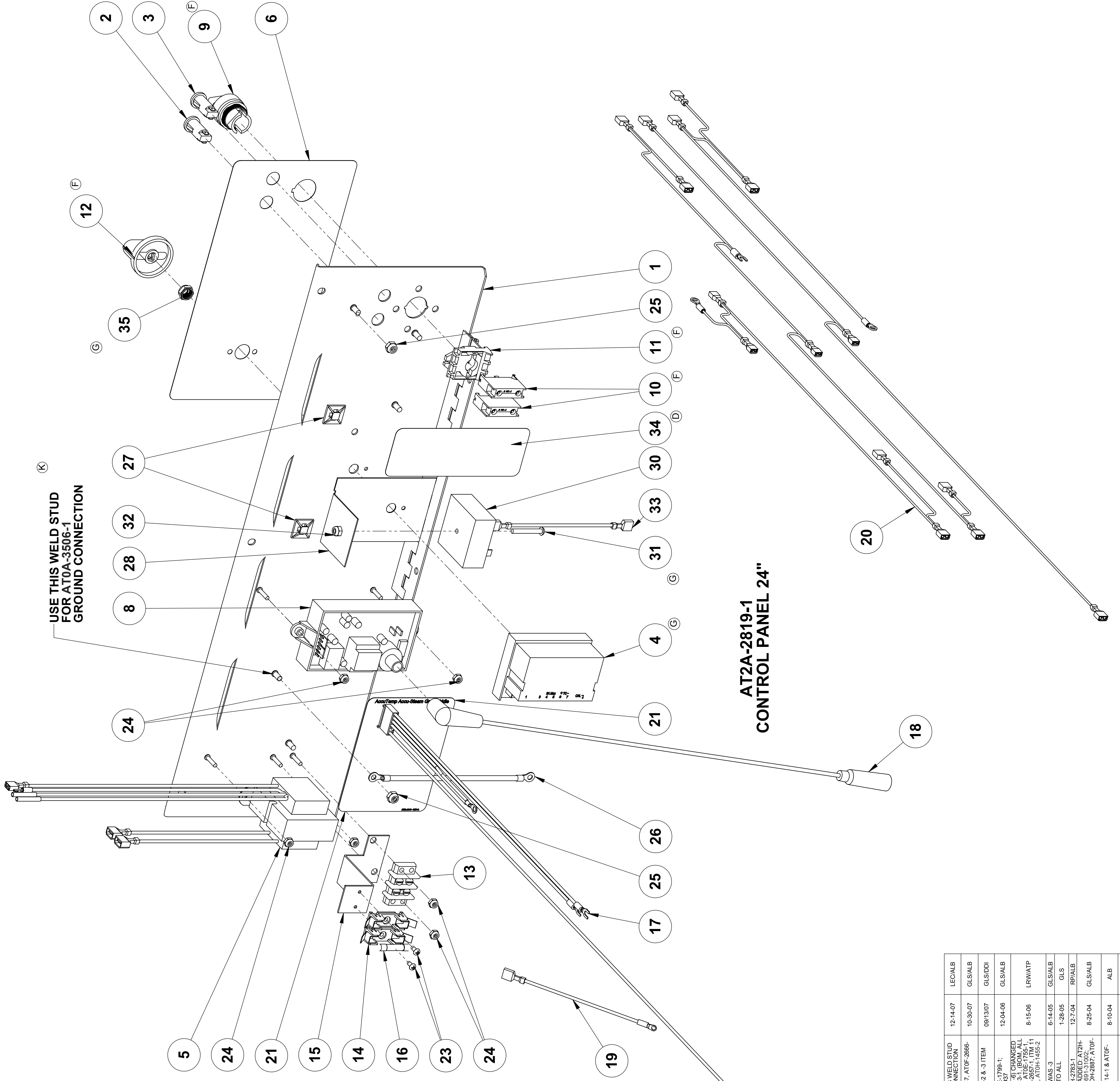

J H G

QTY	AT2A-2819-6	AT2A-2819-5	AT2A-2819-4	AT2A-2819-3	AT2A-2819-2	AT2A-2819-1	PART NO.	ITEM	DESCRIPTION
1	1	1	1	1	1	1			NUT, HEX THIN 3/8-32UNEF-2B
									NUT, ROTARY SHAFT SEAL
									SUPPLEMENTAL DATA TAG
									WIRE HARNESS
									NUT, #6-32 NYLOC
									SCREW, #6-32UNC X 1/4 PHILIPS ROUND HEAD MACHINE
									TIMER RELAY
									OVERLAY, CONTROL PANEL
									TIMER RELAY BRKT
									CABLE TIE MOUNT
									LANYARD
									NUT, #10-24 NYLOC
									NUT, #6-32 NYLOC
									SCREW, #6-32UNC X 1/4 PHILIPS ROUND HEAD MACHINE
									BRACKET TEMP CONTROLLER
									BRACKET TEMP CONTROLLER
									WIRING DIAGRAM
									HARNESS ASSEMBLY
									HARNESS ASSEMBLY
									IGNITION CABLE
									MODULE HARNESS ASSEMBLY
									FUSE 3/4 AMP 250V
									BRACKET FUSE HOLDER
									3AG OMNI-BLOCK FUSE BLOCK 2 POS
									2 POSITION TERMINAL BLOCK
									KNOB FOR D SHAFT
									MOUNTING LATCH
									CONTACT BLOCK
									OPERATOR, AB ROTARY SWITCH
									IGNITION CONTROLLER
									OVERLAY, CONTROL PANEL
									OVERLAY, CONTROL PANEL
									TRANSFORMER ASSEMBLY
									TEMPERATURE CONTROLLER
									INDICATOR LAMP RED INCANDESCENT 28V
									INDICATOR LAMP GRN INCANDESCENT 28V
									CONTROL PANEL WELD ASSY
									CONTROL PANEL WELD ASSY

AccuTemp Products, Inc 8445 N. Clinton Park Fort Wayne, IN 46825			
Name	Date	Checked	Project Eng
ALB	06-19-04	GLS	07-19-04
Tolerances:		Material:	
Angular: ±1°		Surface Finish: .005	
2 Place Decimal		T. R. ±.005	
1 Place Decimal		Y. T. ±.005	
1/25 Micro Inches		Y. T. ±.005	
GDD&T Per ANSI Y14.5M		Finish:	
Do Not Scale Drawing		N/A	

ECN	REV	DESCRIPTION	DATE	APPR
373	K	ADDED: (SHT. 1 & 2) USE THIS WELD STUD FOR AT0A-3506-1 GROUND CONNECTION	12-14-07	LECALB
375	J	RWV/P: (ALL GROUPS) ITEM #37, AT0F-2696-1, 2 & 3 ITEM #37, AT0H-2696-1, 2 & 3 ITEM #37, AT0J-2696-1, 2 & 3 ITEM #37, AT0K-2696-1, 2 & 3 ITEM #37	10-30-07	GLS/ALB
387	H	CHGD: (GROUPS) AT2A-2819-1, 2 & 3 ITEM #37, AT0F-2696-1, 2 & 3 ITEM #37, AT0H-2696-1, 2 & 3 ITEM #37, AT0J-2696-1, 2 & 3 ITEM #37, AT0K-2696-1, 2 & 3 ITEM #37	09/13/07	GLS/DOO
313	G	CHGD: AT0F-2696-1 WAS AT2E-1799-1, 2 & 3 ITEM #37, AT0H-2696-1 WAS AT2E-1799-1, 2 & 3 ITEM #37, AT0J-2696-1 WAS AT2E-1799-1, 2 & 3 ITEM #37, AT0K-2696-1 WAS AT2E-1799-1, 2 & 3 ITEM #37	12-04-06	GLS/ALB
288	F	CHGD: (SHT. 2, GRPS. 2, 3, 5, 8) CHANGED (SHT. 1, GRPS. 1, 2, 4, 7, 9) CHANGED (SHT. 1, GRPS. 1, 2, 4, 7, 9) CHANGED (SHT. 1, GRPS. 1, 2, 4, 7, 9) CHANGED (SHT. 1, GRPS. 1, 2, 4, 7, 9) CHANGED	8-15-06	LRWATP
229	E	CHGD: (SHT. 1, GRPS. 1, 2, 4, 7, 9) CHANGED (SHT. 1, GRPS. 1, 2, 4, 7, 9) CHANGED (SHT. 1, GRPS. 1, 2, 4, 7, 9) CHANGED (SHT. 1, GRPS. 1, 2, 4, 7, 9) CHANGED	6-14-05	GLS/ALB
192	D	CHGD: (SHT. 1, GRPS. 1, 2, 4, 7, 9) CHANGED (SHT. 1, GRPS. 1, 2, 4, 7, 9) CHANGED (SHT. 1, GRPS. 1, 2, 4, 7, 9) CHANGED (SHT. 1, GRPS. 1, 2, 4, 7, 9) CHANGED	1-28-05	GLS
182A	C	CHGD: AT0H-1455-1 WAS AT0H-2793-1, 2 & 3 ITEM #37, AT0J-2696-1 WAS AT0H-2793-1, 2 & 3 ITEM #37, AT0K-2696-1 WAS AT0H-2793-1, 2 & 3 ITEM #37	12-7-04	RP/ALB
182A	B	RELEASED TO PRODUCTION: ADDED: AT2H-2887-1, 2 & 3 ITEM #37, AT2A-2819-1, 2 & 3 ITEM #37, AT2A-2819-2, 2 & 3 ITEM #37, AT2A-2819-3, 2 & 3 ITEM #37, AT2A-2819-4, 2 & 3 ITEM #37, AT2A-2819-5, 2 & 3 ITEM #37, AT2A-2819-6, 2 & 3 ITEM #37	8-25-04	GLS/ALB
182A	A	ADDED: (SHT. 1, GRPS. 1, 2, 4, 7, 9) CHANGED (SHT. 1, GRPS. 1, 2, 4, 7, 9) CHANGED (SHT. 1, GRPS. 1, 2, 4, 7, 9) CHANGED (SHT. 1, GRPS. 1, 2, 4, 7, 9) CHANGED	8-10-04	ALB

ECN	REV	DESCRIPTION	DATE	APPR
373	K	ADDED: (SHT. 1 & 2) USE THIS WELD STUD FOR AT0A-3506-1 GROUND CONNECTION	12-14-07	LECALB
375	J	RWV/P: (ALL GROUPS) ITEM #37, AT0F-2696-1, 2 & 3 ITEM #37, AT0H-2696-1, 2 & 3 ITEM #37, AT0J-2696-1, 2 & 3 ITEM #37, AT0K-2696-1, 2 & 3 ITEM #37	10-30-07	GLS/ALB
387	H	CHGD: (GROUPS) AT2A-2819-1, 2 & 3 ITEM #37, AT0F-2696-1, 2 & 3 ITEM #37, AT0H-2696-1, 2 & 3 ITEM #37, AT0J-2696-1, 2 & 3 ITEM #37, AT0K-2696-1, 2 & 3 ITEM #37	09/13/07	GLS/DOO
313	G	CHGD: AT0F-2696-1 WAS AT2E-1799-1, 2 & 3 ITEM #37, AT0H-2696-1 WAS AT2E-1799-1, 2 & 3 ITEM #37, AT0J-2696-1 WAS AT2E-1799-1, 2 & 3 ITEM #37, AT0K-2696-1 WAS AT2E-1799-1, 2 & 3 ITEM #37	12-04-06	GLS/ALB
288	F	CHGD: (SHT. 2, GRPS. 2, 3, 5, 8) CHANGED (SHT. 1, GRPS. 1, 2, 4, 7, 9) CHANGED (SHT. 1, GRPS. 1, 2, 4, 7, 9) CHANGED (SHT. 1, GRPS. 1, 2, 4, 7, 9) CHANGED	8-15-06	LRWATP
229	E	CHGD: (SHT. 1, GRPS. 1, 2, 4, 7, 9) CHANGED (SHT. 1, GRPS. 1, 2, 4, 7, 9) CHANGED (SHT. 1, GRPS. 1, 2, 4, 7, 9) CHANGED (SHT. 1, GRPS. 1, 2, 4, 7, 9) CHANGED	6-14-05	GLS/ALB
192	D	CHGD: (SHT. 1, GRPS. 1, 2, 4, 7, 9) CHANGED (SHT. 1, GRPS. 1, 2, 4, 7, 9) CHANGED (SHT. 1, GRPS. 1, 2, 4, 7, 9) CHANGED (SHT. 1, GRPS. 1, 2, 4, 7, 9) CHANGED	1-28-05	GLS
182A	C	CHGD: AT0H-1455-1 WAS AT0H-2793-1, 2 & 3 ITEM #37, AT0J-2696-1 WAS AT0H-2793-1, 2 & 3 ITEM #37, AT0K-2696-1 WAS AT0H-2793-1, 2 & 3 ITEM #37	12-7-04	RP/ALB
182A	B	RELEASED TO PRODUCTION: ADDED: AT2H-2887-1, 2 & 3 ITEM #37, AT2A-2819-1, 2 & 3 ITEM #37, AT2A-2819-2, 2 & 3 ITEM #37, AT2A-2819-3, 2 & 3 ITEM #37, AT2A-2819-4, 2 & 3 ITEM #37, AT2A-2819-5, 2 & 3 ITEM #37, AT2A-2819-6, 2 & 3 ITEM #37	8-25-04	GLS/ALB
182A	A	ADDED: (SHT. 1, GRPS. 1, 2, 4, 7, 9) CHANGED (SHT. 1, GRPS. 1, 2, 4, 7, 9) CHANGED (SHT. 1, GRPS. 1, 2, 4, 7, 9) CHANGED (SHT. 1, GRPS. 1, 2, 4, 7, 9) CHANGED	8-10-04	ALB

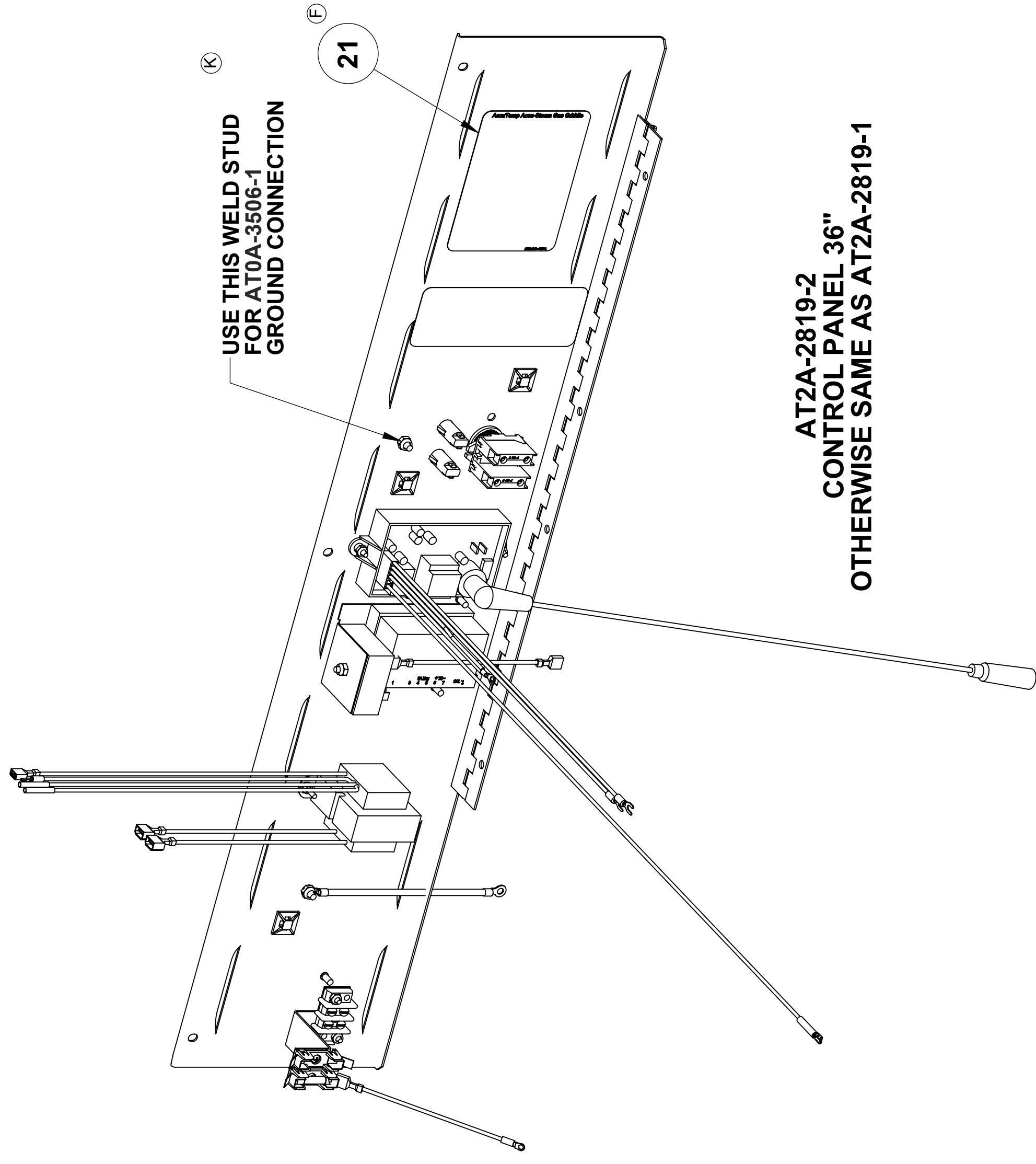

AT2A-2819-2  
CONTROL PANEL 36"  
OTHERWISE SAME AS AT2A-2819-1

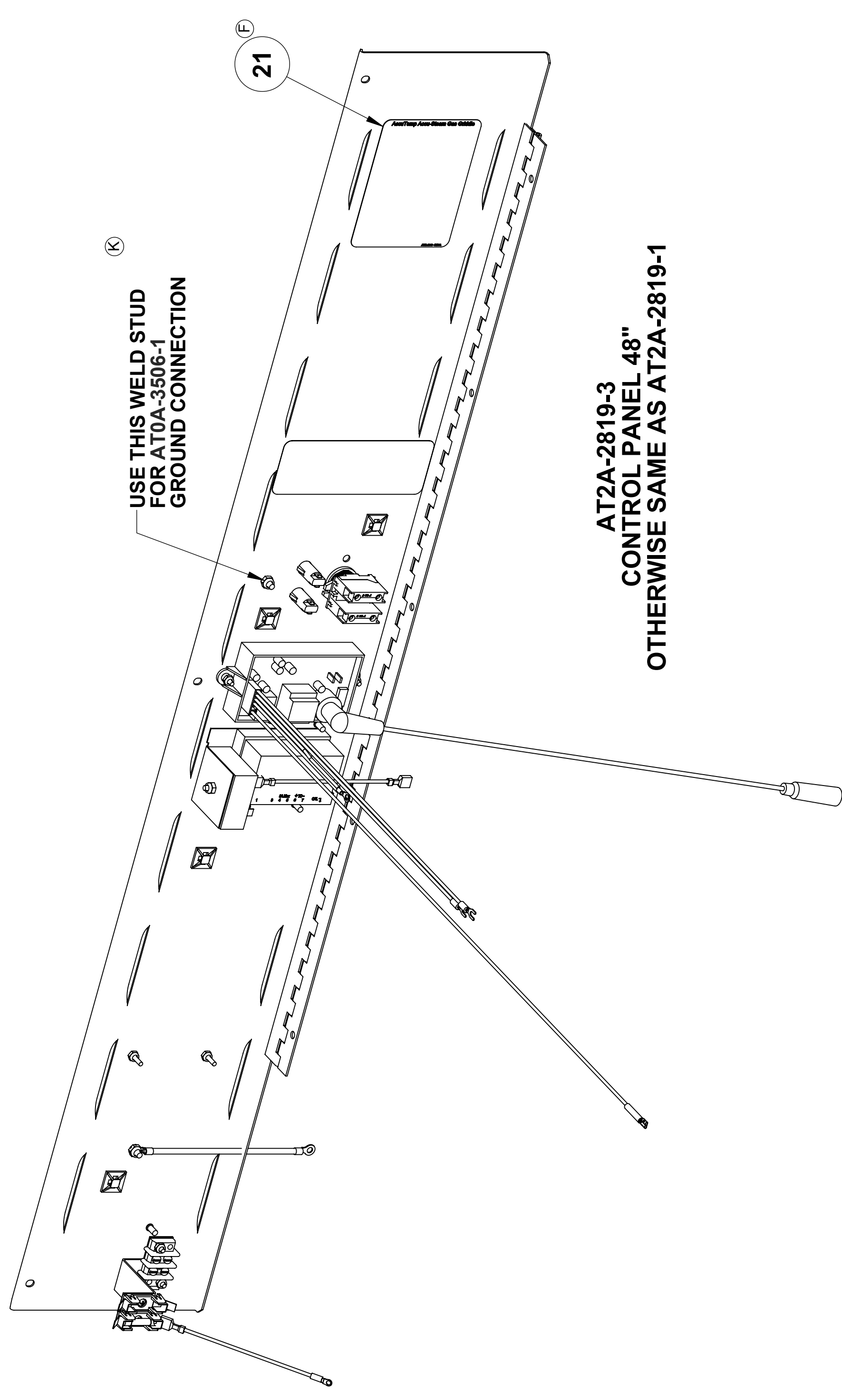

AT2A-2819-3  
CONTROL PANEL 48"  
OTHERWISE SAME AS AT2A-2819-1

Unless otherwise specified,  
Dimensions: Inches  
Bends: 90°  
Tolerances:  
Angular: ±1°  
2 Place Decimal: ±.02  
3 Place Decimal: ±.005  
1 LR: ±.005  
1/125 Micro Inches  
GD&T Per ANSI Y14.5M  
Comments:  
Do Not Scale Drawing

Name	Date
Drawn: ALB	06-19-04
Checked: GJS	07-19-04
Project Eng: GJS	07-19-04
Material:	N/A
Finish:	N/A

AccuTemp Products, Inc  
8415 N. Clinton Park  
Fort Wayne, IN 46825

**AccuTemp**

**CONTROL PANEL**

Rev.	Drawing No.:
<b>K</b>	<b>AT2A-2819</b>

Scale: 1:2 ECN: Sheet 2 of 3

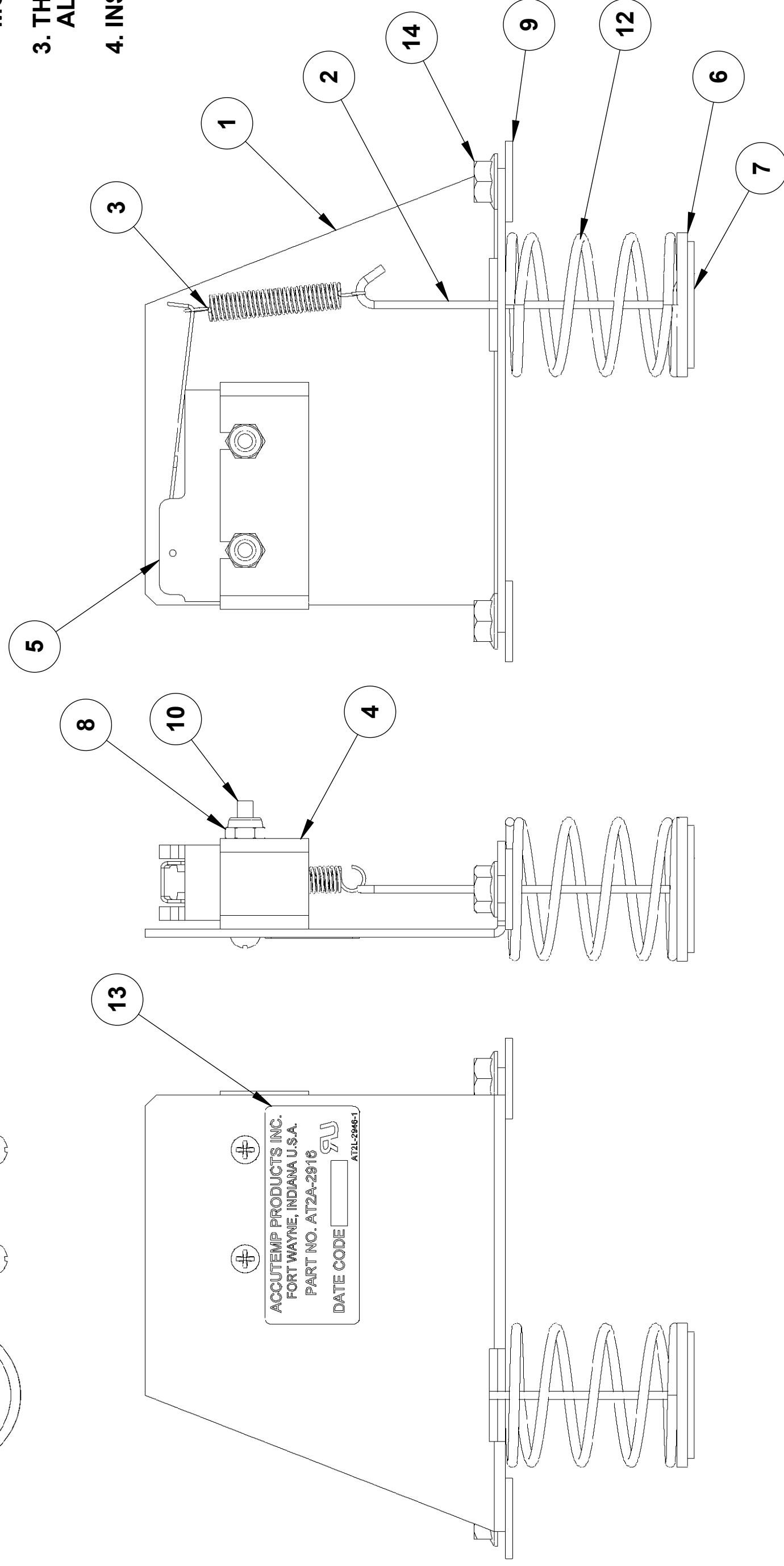
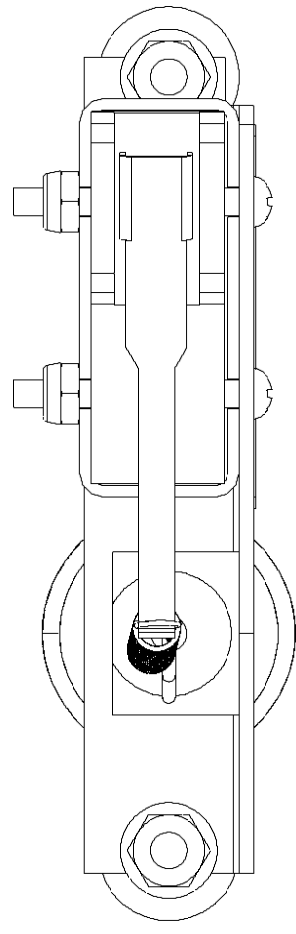

**NOTE:**

1. MANUFACTURING DATE CODE REFLECTS THE DATE OF MANUFACTURE OF THE ROD ASSEMBLY.
2. DATE CODE TO BE PERMANENTLY MARKED WITH YEAR, MONTH, DAY (YYMMDD) AND BATCH LETTER (A) - [YYMMDDA].
3. THE BATCH LETTER IS IDENTIFIED AS A SINGLE ALPHANUMERIC CHARACTER IE. A,B,C ETC.
4. INSTALL DATE CODE LABEL TO BRACKET AS SHOWN.

ACCUTEMP PRODUCTS INC.  
FORT WAYNE, INDIANA U.S.A.  
PART NO. AT2A-2916  
DATE CODE [ ] [ ] [ ] [ ] [ ] [ ] [ ] [ ]  
AT2L-2946-1

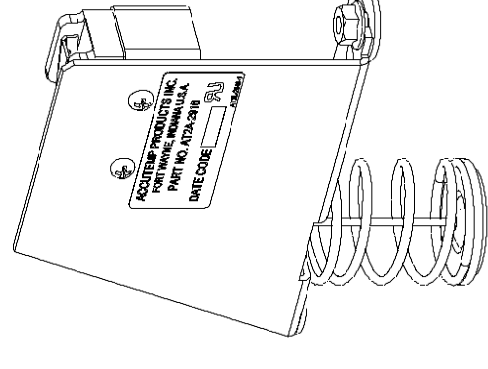

**AT2A-2916-1**

QTY	QTY	PART NUMBER	ITEM	DESCRIPTION
-	2	AT0F-1017-41002	14	NUT, #10-24UNC HEX SERRATED
1	1	AT2L-2946-1	13	DATE CODE LABEL
1	1	AT2H-1365-1	12	COMPRESSION SPRING
1	-	AT2A-2759-1	11	CABLE ASSEMBLY
2	2	AT0F-2755-21102	10	SCREW, #6-32UNC X 1 1/4 PHILIPS ROUND HEAD MACHINE
2	2	AT0F-1052-51002	9	WASHER 1/4 TYPE B PLAIN
2	2	AT0F-2691-21002	8	NUT, #6-32 NYLOC
1	1	AT2M-2860-1	7	SOLDER WASHER
1	1	AT2F-1367-1	6	WASHER, TYPE A
1	1	AT2E-1639-1	5	MICROSWITCH
1	1	AT0E-1759-1	4	MICROSWITCH COVER
1	1	AT2H-1640-1	3	EXTENSION SPRING
1	1	AT2M-2861-1	2	WIRE ROD OVERTEMP
1	1	AT2M-1558-2	1	BRACKET SWITCH RIGHT HAND
AT2A-2916-2	AT2A-2916-1			

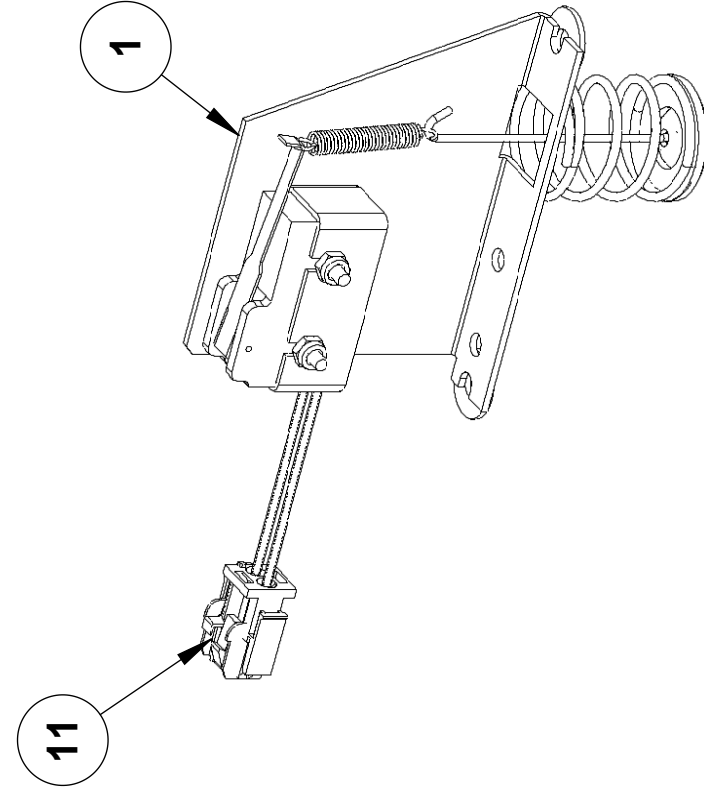

**AT2A-2916-2  
OTHERWISE SAME AS AT2A-2916-1**



Unless otherwise specified:  
Dimensions: Inches  
Bends: 90°  
Tolerances:  
Angular: +1°  
2 Place Decimal: ±.02  
3 Place Decimal: ±.005  
T.I.R.: ±.005  
±.125 Micro inches  
GD&T Per ANSI Y14.5M  
Comments:  
Do Not Scale Drawing

Name	Date
Drawn: ALB	07-22-04
Checked: DPS	07-22-04
Project Eng: DPS	07-22-04
Material: N/A	
Finish: N/A	

**HIGH LIMIT  
OVERTEMP ASSEMBLY**  
Drawing No.: **C AT2A-2916**  
Rev: **B**  
Scale: 1:1 EDR: 057  
Sheet 1 of 1

ECN	REV	DESCRIPTION	DATE	APPR
380	B	CHG'D: (AT2A-2916-1) AT2M-1558-2 WAS AT2M-1558-1	11-30-07	DPS/ALB
135	A	REMOVED: AT2A-2916-3 & -4; CHG'D: AT2L-2946-1 WAS AT2L-1851; AT0F-1052-51002 WAS AT2F-1643	08-16-04	ALB

REVISIONS



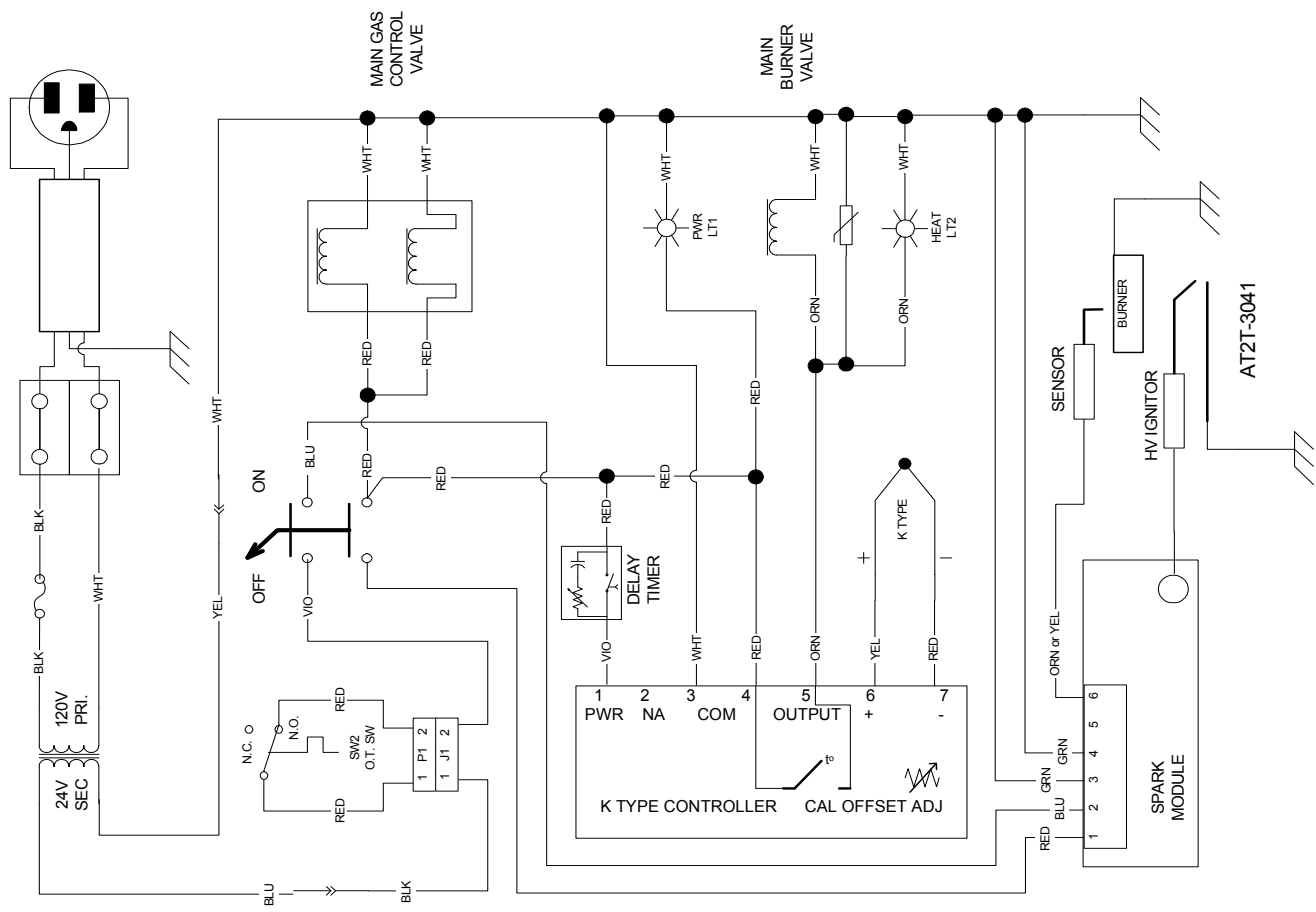

# WARRANTY

---

---

## LIMITED WARRANTY

### One Year – Parts and Labor U.S. & Canada Only

AccuTemp Products, Inc. (AccuTemp) warrants that your AccuTemp equipment will be free of defects in material and workmanship under normal use for a period of twelve (12) months from installation or fifteen (15) months from date of shipment from AccuTemp, whichever date first occurs (the Warranty Period). Registration of AccuTemp equipment is required at the time of installation. Damage to AccuTemp equipment that occurs during shipment must be reported to the carrier, and is not covered under this warranty. The reporting of any damage during shipment is the sole responsibility of the commercial purchaser/user of such AccuTemp equipment.

AccuTemp provides an active service department, which should be contacted and advised of service issues, regardless of the warranty period. During the warranty period, AccuTemp agrees to repair or replace, at its option, F.O.B. factory, any part which proves to be defective due to defects in material or workmanship, provided the equipment has not been altered in any way and has been properly installed, maintained, and operated in accordance with the instructions in the AccuTemp Owners Manual. During the warranty period, AccuTemp also agrees to pay for any factory authorized equipment service agency (within the continental United States and Canada) for reasonable labor required to repair or replace, at our option, F.O.B. factory, any part which proves to be defective due to defects in materials or workmanship, provided the service agency has received advance approval from AccuTemp factory service to perform the repair or replacement. This warranty includes travel time not to exceed two hours and mileage not to exceed 50 miles (100 miles round trip), but does not include post start-up assistance or training, tightening of loose fittings or external electrical connections, minor adjustments, maintenance, or cleaning. AccuTemp will not reimburse the expense of labor required to replace parts after the expiration of the warranty period.

Proper installation is the responsibility of the dealer, owner-user, or installing contractor and is not covered by this warranty. Improper installation can affect your warranty. Installation is the responsibility of the Dealer, Owner/User or the Installation Contractor. See the Installation section of the Owners Manual. While AccuTemp products are built to comply with applicable standards for manufacturers, including Underwriters Laboratories (UL) and National Sanitation Foundation (NSF), it is the responsibility of the owner and the installer to comply with any applicable local codes that may exist.

AccuTemp makes no other warranties or guarantees, whether expressed or implied, including any warranties of performance, merchantability, or fitness for any particular purpose. AccuTemp's liability on any claim of any kind, including negligence, with respect to the goods and services covered hereunder, shall in no case exceed the price of the goods and services, or parts thereof, which gives rise to the claim. In no event shall AccuTemp be liable for special, incidental, or consequential damages, or damages in the nature of penalties.

This constitutes the entire warranty, which supersedes and excludes all other warranties, whether written, oral, or implied.



## Gas Griddle Periodic Maintenance (PM) Recommendations

**NOTE:** AccuTemp-approved service providers should complete these PM tasks.

PM TASK DESCRIPTIONS	DAILY ITEMS	BI- ANNUAL ITEMS	ANNUAL ITEMS
1. Verify that the griddle is level and properly located under the hood.	X		
2. Verify the operation of the indicator lamps.	X		
3. Verify the operation of the power switches. The switches should turn easily and tight against control panel. If there is evidence of damage to switch consider installing guards.	X		
4. Verify the operation of the thermostat knob. The knob should turn easily with no binding. Remove the knob and check for any corrosion on the shaft. If there is evidence of damage to knob consider installing guards.	X		
5. Inspect the control panel seal for proper location and condition. All surfaces should be wiped with a solution of a mild detergent and water and rinsed with clean water. If there is evidence that grease has migrated into control panel consider installing a new seal.	X	X	X
6. Inspect the control compartment for foreign particulate and any loose wiring or connections.		X	X
7. <b>Daily</b> inspect the flue for foreign particulate that has fallen inside. Remove any particulate. Consider installation of a back draft diverter, which will keep scrapings from spatulas from dropping down the flue and will provide additional protection from back drafts that, can effect stand-by burner operation. Check that the flue has not been pushed in. If the flue has been pushed in, pull the flue out so that flue opening is at the original shape.	X	X	X
8. Verify the operation and condition of the igniter probe assembly. Probes should be cleaned with a wire brush and/or emery cloth. If probe is not one that uses ceramic adhesive it should be changed to one that does. Date code on probe should be "0717" or higher. <b>Caution: DO NOT use any abrasive that contains aluminum oxide. This will leave a coating on the flame sensor that could cause the unit not to light.</b>		X	X
9. Clean all gas orifices, making sure the orifices are clear and free. <b>Note: It maybe necessary to clean the pilot orifice more often.</b>		X	X

PM TASK DESCRIPTIONS	DAILY ITEMS	BI-ANNUAL ITEMS	ANNUAL ITEMS
10. Inspect the burner venturi tubes for foreign particles. Wipe out with a mild detergent and warm water and rinse with clean water.		X	X
11. Inspect combustion chamber and the burner tiles. If water stains are present on tiles check that tiles have no cracks and haven't sunk into the burner. Replace burners if this condition is present. If when cleaning the vent hood water and solvent drip down into the flue, consider adding a back draft diverter. This device keeps foreign material out of flue and combustion chamber. Serious consideration should be given since most solvents used for cleaning hoods are corrosive to the ceramic tiles.		X	X
12. Inspect the ignition wire harness for any evidence of high temperature degradation or grease build-up on the harness connector. Spray contact cleaner into white connector and clean mating connector imbedded in ignition module. Replace harness if it doesn't have high heat quick disconnect on end of orange wire. Install heat shield if not already installed.		X	X
13. Verify ignition module voltage (MV) output greater than 30 MV. Must have AccuTemp adaptor ATR-FT003 to check millivolts. Install ground strap between stand-by burner and control panel to improve ground plane performance.		X	X
14. Verify pilot burner and main burner regulator pressures. Check that stand-by burner tile is flush with surface of burner and if not replace pilot burner.			X
15. Check output of control transformer after unit has been running for several hours. The output of the secondary coil must be greater than 20 volts or if less than this replace transformer.		X	X



Phone: (800) 480-0415  
 Fax: (260) 493-8914  
 Hours: 7 Days a Week  
 7:00 a.m. – 7:00 p.m. (EST)

**Gas Griddle Periodic Maintenance (PM) Recommendations (cont.)**  
**AccuTemp Products, Inc.**

**Gas Pressures**

The griddle requires the proper gas pressure setting to operate properly. All pressure readings should be taken after the unit has reached a temperature of at least 200°F and while it is **running** to ensure proper flow rates.

- Required Material:**
- Manometer
  - 1/8" NPT barbed hose fitting
  - 1/4" NPT barbed hose fitting
  - Two 2-inch long lengths of approximately 1/8" diameter flexible rubber hose (closed on one end)

**Tasks:**

- 1) Verify pressure regulator vents are clear before making any pressure adjustments.
- 2) Remove the 1/8" NPT pipe plug from the main gas valve and install the 1/8" NPT barbed hose fitting. Tighten and mount one length of the rubber hose.
- 3) Remove the 1/4" NPT pipe plug from the downstream fitting after the pilot burner pressure regulator and install 1/4" NPT barbed hose fitting. Tighten and mount the other length of the rubber hose.
- 4) Allow the griddle to heat up to at least 200°F. First, check the main burner regulator pressure. Remove the rubber hose and replace with the manometer tube. The pressure should be 5" WC for natural gas and 10" WC for propane (**Caution: Pressure must be set with the main burners on.**) If the pressure does not meet or exceed these values, remove the cap on the main burner pressure regulator and adjust it to the necessary value.
- 5) Check the pilot burner pressure (pilot burner regulator) in the same manner as the main burner pressure. The pressure should measure 3.5" WC for natural gas and 8" WC for propane. If the pressure does not meet or exceed these values, remove the cap on the pilot burner pressure regulator and adjust it to the necessary value.
- 6) Replace the hose fittings with original pipe plugs.

**Gas Griddle Periodic Maintenance (PM) Recommendations (cont.)**  
**AccuTemp Products, Inc.**

**Igniter Probe Assembly**

The igniter probes ignite and sense that the pilot burner is operational. Depending on the kitchen-cooking environment, geographic location and cleaning solutions used, the ventilation airflow can deposit airborne material onto the probes, causing the pilot burner to have difficulty lighting or sensing that it is operational.

- Required Material:**
- AccuTemp adaptor part #ATR-FT003
  - Nut-driver/wrench
  - Phillips screwdriver
  - Steel brush,
  - Voltmeter

**Tasks:**

- 1) Remove the retaining screws and remove the probe assembly.
- 2) Brush all probes to remove foreign material.
- 3) Re-install the probe assembly and verify operation.
- 4) Check millivolts by grounding black lead of adaptor to the chassis, then inserting the red lead into socket of the connector containing the orange lead to the flame sensor. Reading should be above 30 millivolts.

**Orifices and Burner Venturi**

Pilot and main burner orifices can collect dust and grease over time in any kitchen environment. If this material blocks the orifices, the griddle will be less efficient and can cause intermittent operation or complete shutdown.

Depending on the size of your griddle, there are a minimum of 3 and a maximum of 4 orifices that require inspection and cleaning. Each main burner will have an orifice and each griddle's pilot burner will have an orifice.

- Required Material:**
- Towel
  - Soap and warm water
  - Stiff wire smaller than the orifice nozzle or orifice drill of the same size hole.

**Tasks:**

- 1) Dampen a towel with the soap and water solution and clean the orifice.
- 2) Take the stiff wire or orifice drill and insert it into the hole in the center of the orifice and run it back and forth, making sure all foreign material is removed.
- 3) Clean the burner venturi opening so that it is free of any collected dust, grease and any other foreign substances.

# ACCU-STEAM™ Gas Griddle Start-Up Form

AccuTemp Products, Inc.

Location: \_\_\_\_\_ Address: \_\_\_\_\_

City: \_\_\_\_\_ State: \_\_\_\_\_ Zip: \_\_\_\_\_ Ph# \_\_\_\_\_

Serial Number \_\_\_\_\_ Model Number: \_\_\_\_\_

Service Agency: \_\_\_\_\_ Technician: \_\_\_\_\_

**NOTE:** AccuTemp Products, Inc. is not responsible for the installation and/or modifications to the electrical or gas supply sources.

Is the 120 VAC wall receptacle position in a low heat zone. (circle one) Yes / No  
*(Note: It is recommended that the wall receptacle be placed as low as State and Local codes allow. Placement in high heat zones such as, just above, below or beside the exhaust flue, will cause service issues that will not be covered under the product warranty.)*

Is an external regulator connected to the griddle? (circle one) Yes / No  
*(NOTE: An external regulator should not be used unless the supply gas pressure is more than 0.5 psig.)*

Is the griddle being installed at an altitude greater than 4,000 feet? (circle one) Yes / No  
*(NOTE: If the altitude is greater than 4,000 feet above sea level, contact the AccuTemp Technical & Customer Support Department to verify the correct orifice sizes for the pilot and main burners.)*

If this is a table top installation, have the (4) rubber foot tips been installed ? (circle one) Yes / No

Is the griddle level ? (circle one) Yes / No

Is the grease pan installed (circle one) Yes / No

Is the griddle hard connected to the gas supply line? (circle one) Yes / No

If the griddle is connected with a flexible hose, is a restraining device used? (circle one) Yes / No

Gas Pressure Measurements:

Natural : \_\_\_\_\_ 5" WC (Regulator Valve – 1/8" NPT) \_\_\_\_\_ 3.5" WC (Pilot Regulator – 1/4" NPT)

Propane : \_\_\_\_\_ 10" WC (Regulator Valve – 1/8" NPT) \_\_\_\_\_ 8" WC (Pilot Regulator – 1/4" NPT)

Does the griddle operate properly when all gas appliances are operating? (circle one) Yes/No

Verify the actual surface temperature at a thermostat setting of 375° F ( \_\_\_\_\_ ° F)  
(use a contact temperature probe instead of an infrared thermometer to measure the temperature)

I accept this Start-Up Form as complete and accurate:

\_\_\_\_\_ Restaurant Management      Date: \_\_\_/\_\_\_/\_\_\_

**Note:** This Start-Up Form must be completely filled out and faxed or mailed to the AccuTemp Technical & Customer Support Department, before the warranty is activated.

AccuTemp Products, Inc  
Attn: Technical & Customer Support Department  
8415 North Clinton Park  
Ft. Wayne, IN 46825  
Phone: +1-260-469-0415 or 1-800-480-0415  
Fax: +1-260-493-8914