

ALTO SHAAM®

OPERATION and CARE MANUAL



750-GDU/PT
(control side)
on optional
casters

LIGHTED DISPLAY CABINETS, HOT FOOD



750-GDU/MET
(multiple timers)
control side

Models:

750-GDU

750-GDU/PT

750-GDU/MET

750-GDU/MET/PT

HALO
HEAT

COOK/HOLD/SERVE SYSTEMS

24•7
Your Service Hotline
1-800-558-8744

W164 N9221 Water Street • P.O. Box 450 • Menomonee Falls, Wisconsin 53052-0450 U.S.A

PHONE: 262.251.3800
800.558.8744 U.S.A./CANADA

FAX: 262.251.7067 • 800.329.8744 U.S.A./CANADA ONLY
262.251.1907 INTERNATIONAL

WEBSITE:
www.alto-shaam.com

ALTO-SHAAM® — DISPLAY CABINETS

UNPACKING and SET-UP

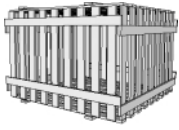

Alto-Shaam display cabinets have been thoroughly tested, checked for calibration, and inspected to insure only the highest quality cabinet is provided.

When you receive your cabinet, check for any possible shipping damage and

report it at once to the delivering carrier. See

Transportation Damage and Claims section located in this manual.

The cabinet, complete with unattached items and accessories, may be delivered in one or more packages. Check to ensure that all the following items have been received as standard with each unit.

- 2: Chrome Plated Side Racks
- 3: Chrome Plated Wire Shelves
- 2: 40 Watt Appliance Bulbs

Save all the information and instructions packed inside the cabinet. Complete and return the warranty card to the factory as soon as possible to assure prompt service in the event of a warranty parts and labor claim.

NOTE: All claims for warranty must include the full model number and serial number of the cabinet.

ELECTRICAL INSTALLATION

An identification tag is permanently mounted on the cabinet.

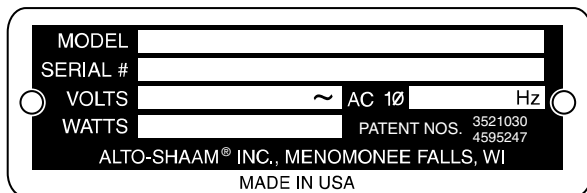

Plug the cabinet into a properly grounded receptacle **ONLY**, remembering to position the unit so that the cord is easily accessible in an emergency.

A proper outlet configuration or permanent wiring for this model must be installed by a licensed electrician in accordance with applicable, local electrical codes.

**Ensure power source
matches voltage stamped
on unit nameplate.**



At no time should the inside or outside of the cabinet be washed down, flooded with water or liquid solution. Do not use water jet to clean. NEVER STEAM CLEAN. Severe damage or electrical hazard could result, voiding the warranty.

HEATING CHARACTERISTICS

The cabinet is equipped with a special, low-heat-density, heating cable. Through the Halo Heat concept, the heating cable is mounted against the walls of the warming compartment to provide an evenly applied heat source controlled by a thermostat. The design and operational characteristics of the cabinet eliminate the need for a moisture pan or a heat circulating fan. Through even heat application, the quality of food is maintained for as much as several hours.

EQUIPMENT STARTUP

Before operating the cabinet, clean both the interior and exterior of the unit with a damp cloth and mild soap solution. Rinse carefully. A standard commercial glass cleaner can be used on all glass. Install the optional casters or equipment legs before operating the cabinet. Clean and install the cabinet side racks, and wire shelves.

CARE AND CLEANING

The cleanliness and appearance of this unit will contribute considerably to operating efficiency and savory, appetizing food. Good equipment that is kept clean works better and lasts longer.



THOROUGHLY CLEAN THE UNIT DAILY

1. Turn lights and adjustable thermostat(s) to the "OFF" position, and disconnect unit from power source.
2. Remove, cover, and store food under refrigeration.
3. Clean the interior metal surfaces of the cabinet with a damp cloth and any good alkaline or alkaline chlorinated based commercial detergent or grease solvent at the recommended strength. Use a plastic scouring pad or oven cleaner for difficult areas. Avoid the use of abrasive cleaning compounds, chloride based cleaners, or cleaners containing quaternary salts. Rinse carefully to remove all residue and wipe dry.

NOTE: Never use hydrochloric acid (muriatic acid) on stainless steel.

4. Clean the glass with a window cleaner.
5. To help maintain the protective film coating on polished stainless steel, clean the exterior of the unit with a cleaner recommended for stainless steel surfaces. Spray the cleaning agent on a clean cloth and wipe with the grain of the stainless steel.



NO SCRAPERS



NO STEEL PADS

Always follow appropriate state or local health (hygiene) regulations regarding all applicable cleaning and sanitation requirements for equipment.

OPERATION PROCEDURES

LIGHTED HOLDING CABINETS



1. PREHEAT AT 200°F (93°C) FOR 30 MINUTES.

When the thermostat is turned clockwise to the **ON** position, the indicator light will illuminate and will remain lit as long as the

unit is calling for heat. Allow a minimum of 30 minutes of preheating before loading the display cabinet with food. The indicator light will go **OUT** after approximately 30 minutes preheat time, or when the air temperature inside the unit reaches the temperature set by the operator.

2. LOAD THE CABINET WITH HOT FOOD ONLY.

The purpose of the holding cabinet is to maintain hot food at proper serving temperature. **Only hot food should be placed into the cabinet.**

Before loading the cabinet with food, use a food thermometer to make certain all products are at an internal temperature range of 140° to 160°F (60° to 71°C). Any food product not within the proper temperature range should be heated before loading into the holding cabinet.

3. RESET THE THERMOSTAT TO 160°F (71°C).

Check to make certain the cabinet doors are securely closed, and reset the thermostat to 160°F (71°C).

THIS WILL NOT NECESSARILY BE THE FINAL SETTING.

The proper temperature range for the products being held will depend on the type and quantity of product. When holding food for prolonged periods, it is advisable to periodically check the internal temperature of each item with a food thermometer to assure maintenance of the proper temperature range of 140° to 160°F (60° to 71°C).

LIGHTED HOLDING CABINETS with MULTIPLE TIMERS



1. SWITCH POWER ON.
The timers will beep and the temperature display will flash momentarily. The unit will begin preheating to the last set holding temperature. The

temperature display will indicate the **actual** cabinet temperature.



2. SET THE HOLDING TEMPERATURE.

A. Press and release the "temperature set" button. The previously set holding temperature will be displayed for 3 seconds. The set holding temperature can be changed during the 3 second time period.

B. To increase the holding temperature, press and hold the "temperature increase" button. The maximum set temperature is 200°F (93°C).

C. To decrease the holding temperature, press and hold the "temperature decrease" button. The minimum set temperature is 60°F (16°C).

3. SET THE 2 HOUR COUNT-DOWN TIMER.

A. To set the count-down timer, press and hold the "time increase" or the "time decrease" button. (The timers are adjustable. ie: one minute to two hours)

B. To start the count-down, press the "start/stop" button.

C. The timer will beep for 3 seconds when the count-down time has expired.

4. TO RESET THE 2 HOUR COUNT-DOWN TIMER:

A. To reset the count-down timer the count-down time must have elapsed and the display must display "0." (Press the "start/stop" button to end the count-down timer manually.)

B. To increase the set count-down time, press and hold the "time increase" button.

C. To decrease the set count-down time, press and hold the "time decrease" button.



The Digital Displays Must Be Allowed to Regenerate Each Time Power is Switched to the "OFF" Position. Before Switching the Power Back ON, Always Allow the Control to Remain in the OFF Position for a Minimum of 30 Seconds.

SANITATION GUIDELINES

Food flavor and aroma are usually so closely related that it is difficult, if not impossible, to separate them. There is also an important, inseparable relationship between cleanliness and food flavor. Cleanliness, top operating efficiency, and appearance of equipment contribute considerably to savory, appetizing foods. Good equipment that is kept clean, works better and lasts longer.

Most food imparts its own particular aroma and many foods also absorb existing odors. Unfortunately, during this absorption, there is no distinction between GOOD and BAD odors. The majority of objectionable flavors and odors troubling food service operations are caused by bacteria growth. Sourness, rancidity, mustiness, stale or other OFF flavors are usually the result of germ activity.

The easiest way to insure full, natural food flavor is through comprehensive cleanliness. This means good control of both visible soil (dirt) and invisible soil (germs). A thorough approach to sanitation will provide essential cleanliness. It will assure an attractive appearance of equipment, along with maximum efficiency and utility. More importantly, a good sanitation program provides one of the key elements in the prevention of food-borne illnesses.

A controlled holding environment for prepared foods is just one of the important factors involved in the prevention of food-borne illnesses. Temperature monitoring and control during receiving, storage, preparation, and the service of foods are of equal importance.

INTERNAL FOOD PRODUCT TEMPERATURES		
HOT FOODS		
DANGER ZONE	40° TO 140°F	(4° TO 60°C)
CRITICAL ZONE	70° TO 120°F	(21° TO 49°C)
SAFE ZONE	140° TO 165°F	(60° TO 74°C)
COLD FOODS		
DANGER ZONE	ABOVE 40°F	(ABOVE 4°C)
SAFE ZONE	36°F TO 40°F	(2°C TO 4°C)
FROZEN FOODS		
DANGER ZONE	ABOVE 32°F	(ABOVE 0°C)
CRITICAL ZONE	0° TO 32°F	(-18° TO 0°C)
SAFE ZONE	0°F OR BELOW	(-18°C OR BELOW)

The most accurate method of measuring safe temperatures of both hot and cold foods is by internal product temperature. A quality thermometer is an effective tool for this

purpose, and should be routinely used on all products that require holding at a specific temperature.

A comprehensive sanitation program should focus on the training of staff in basic sanitation procedures. This includes personal hygiene, proper handling of raw foods, cooking to a safe internal product temperature, and the routine monitoring of internal temperatures from receiving through service.

Most food-borne illnesses can be prevented through proper temperature control and a comprehensive program of sanitation. Both these factors are important to build quality service as the foundation of customer satisfaction. Safe food handling practices to prevent food-borne illness is of critical importance to the health and safety of your customers. HACCP, an acronym for Hazard Analysis (at) Critical Control Points, is a quality control program of operating procedures to assure food integrity, quality, and safety. Taking steps necessary to augment food safety practices are both cost effective and relatively simple. While HACCP guidelines go far beyond the scope of this manual, additional information is available by contacting the USDA/FDA Food-borne Illness Education Information Center at (301)504-6803.

GENERAL HOLDING GUIDELINES

Chefs, cooks and other specialized food service personnel employ varied methods of cooking. Proper holding temperatures for a specific food product must be based on the moisture content of the product, product density, volume, and proper serving temperatures. Safe holding temperatures must also be correlated with palatability in determining the length of holding time for a specific product.

Halo Heat maintains the maximum amount of product moisture content without the addition of water, water vapor, or steam. Maintaining maximum natural product moisture preserves the natural flavor of the product and provides a more genuine taste. In addition to product moisture retention, the gentle properties of Halo Heat maintain a consistent temperature throughout the cabinet without the necessity of a heat distribution fan, thereby preventing further moisture loss due to evaporation or dehydration.

In an enclosed holding environment, too much moisture content is a condition which can be relieved. A product achieving extremely high temperatures in preparation must be allowed to decrease in temperature before being placed in a controlled holding atmosphere. If the product is not allowed to decrease in temperature, excessive condensation will form increasing the moisture content on the outside of the product.

Most Halo Heat Holding Equipment is provided with a thermostat control between 60° and 200°F (16° to 93°C). If the unit is equipped with vents, close the vents for moist holding and open the vents for crisp holding.

If the unit is equipped with a thermostat indicating a range of between 1 and 10, use a metal-stemmed indicating thermometer to measure the internal temperature of the product(s) being held. Adjust the thermostat setting to achieve the best overall setting based on internal product temperature.

HOLDING TEMPERATURE RANGE		
	FAHRENHEIT	CELSIUS
MEAT		
BEEF ROAST — Rare	140°F	60°C
BEEF ROAST — Med/Well Done	160°F	71°C
BEEF BRISKET	160° — 175°F	71° — 79°C
CORN BEEF	160° — 175°F	71° — 79°C
PASTRAMI	160° — 175°F	71° — 79°C
PRIME RIB — Rare	140°F	60°C
STEAKS — Broiled/Fried	140° — 160°F	60° — 71°C
RIBS — Beef or Pork	160°F	71°C
VEAL	160° — 175°F	71° — 79°C
HAM	160° — 175°F	71° — 79°C
PORK	160° — 175°F	71° — 79°C
LAMB	160° — 175°F	71° — 79°C
POULTRY		
CHICKEN — Fried/Baked	160° — 175°F	71° — 79°C
DUCK	160° — 175°F	71° — 79°C
TURKEY	160° — 175°F	71° — 79°C
GENERAL	160° — 175°F	71° — 79°C
FISH/SEAFOOD		
FISH — Baked/Fried	160° — 175°F	71° — 79°C
LOBSTER	160° — 175°F	71° — 79°C
SHRIMP — Fried	160° — 175°F	71° — 79°C
BAKED GOODS		
BREADS/ROLLS	120° — 140°F	49° — 60°C
MISCELLANEOUS		
CASSEROLES	160° — 175°F	71° — 79°C
DOUGH — Proofing	80° — 100°F	27° — 38°C
EGGS — Fried	150° — 160°F	66° — 71°C
FROZEN ENTREES	160° — 175°F	71° — 79°C
HORS D'OEUVRES	160° — 180°F	71° — 82°C
PASTA	160° — 180°F	71° — 82°C
PIZZA	160° — 180°F	71° — 82°C
POTATOES	180°F	82°C
PLATED MEALS	180°F	82°C
SAUCES	140° — 200°F	60° — 93°C
SOUP	140° — 200°F	60° — 93°C
VEGETABLES	160° — 175°F	71° — 79°C

THE HOLDING TEMPERATURES LISTED ARE SUGGESTED GUIDELINES ONLY

THERMOSTAT/INDICATOR LIGHT SEQUENCE

Whenever the dial thermostat is turned ON, the light will indicate the power ON/OFF condition of the heating cable; and consequently, the cycling of the cabinet as it maintains the dialed cavity temperature. If the indicator light does not illuminate after normal start-up, the main power source, thermostat, and/or light must be checked. If the warming cabinet does not hold the temperature as dialed, the calibration of the thermostat must be checked. If the warming cabinet fails to heat or heats continuously with the thermostat "OFF," the thermostat must be initially checked for proper operation. If these items are checked and found to be in order, a continuity and resistance check of the heating cable should be made. SEE CIRCUIT DIAGRAM.

THERMOSTAT CALIBRATION

MANUAL (DIAL) THERMOSTATS

The thermostat is precision calibrated at the factory. Normally, no adjustment or recalibration is necessary unless the thermostat has been mishandled in transit, changed or abused while in service. A thermostat with a sensing bulb operates on hydraulic pressure; consequently, any bending of the bulb results in a change in its volume, and alters the accuracy of the thermostat calibration.

A thermostat should be checked or recalibrated by placing a quality, thermal indicator at the center of an empty holding cavity. **DO NOT CALIBRATE WITH ANY FOOD PRODUCT IN THE CABINET.** The thermostat should be set at 140°F (60°C), and should be allowed to stabilize at that setting for a minimum of one hour. Following temperature stabilization, the center of the thermal swing of the air temperature within the cabinet should approximately coincide with the thermostat setting.

If calibration is necessary, the calibration screw should be adjusted with great care. The calibration screw of the thermostat is located in the thermostat dial shaft. With the shaft held stationary, a minute, clockwise motion of the calibration screw appreciably lowers the thermostat setting. A reverse, or counter-clockwise motion appreciably raises the thermostat setting. After achieving the desired cycling of the thermostat, the calibration screw must be sealed. Place a few drops of enamel sealant directly on the calibration screw. (RED NAIL POLISH OR EQUIVALENT IS ACCEPTABLE.)

ELECTRONIC THERMOSTATS

The electronic thermostat has been set at the factory to indicate in degrees Fahrenheit or degrees Celsius as requested at the time of order. The temperature scale can be changed in the field only by an authorized Alto-Shaam service agency.

The electronic thermostat is a precise instrument and is designed to offer trouble free service. If you suspect the temperature inside the holding compartment does not match the temperature indicated on the digital display, follow the instructions listed below.

1. Check to make certain the unit voltage matches the power source. A power source less than that required to operate the unit will result in inaccurate temperatures.
2. Verify the temperature inside the holding compartment with a quality thermal indicator.
 - A. With the exception of the wire shelves, completely empty the holding compartment.
 - B. Make certain the holding cabinet sensor, located inside the holding compartment at the left side of the unit, is completely clean.
 - C. Suspend the thermal indicator in the center of the holding compartment.
 - D. Allow the temperature set on the electronic thermostat to stabilize for a minimum of one hour before comparing the digital display with the reading on the thermal indicator.**Do not open the cabinet door(s) during the temperature stabilization period.**

If the reading on the thermal indicator does not match the digital display within 10°F (6°C), see troubleshooting section in this manual, or contact factory.

(INFORMATION ON ELECTRONIC THERMOSTATS— PG 5)



This chart is provided for the assistance of qualified technicians only and is not intended for use by untrained or unauthorized service personnel. If your unit is not operating properly, check the following before calling your authorized service agent. Check the power applied to the unit. Plug in outlet? Fuse OK?

Do not attempt to repair or service beyond this point. Contact manufacturer for nearest authorized service agent. Repairs made by any other service agent without prior authorization by manufacturer will void the warranty on the unit.

Trouble Shooting Guide

Error Code	Possible Cause	Action Required
<p>1. Control displays "000".</p>	<p>A. Sensor is open circuited.</p> <p>B. Associated wiring is open circuited.</p> <p>C. Control is faulty.</p>	<p>Detach the sensor from the terminal block. Use an Ohm meter to measure the resistance of the sensor. Check sensor at 32°F (0°C) using a container of ice water. If Ohm reading is 100, replace display. If Ohm reading is not 100, replace sensor.</p> <p>Check wires for integrity. Check for proper and secure connections at the thermostat and terminal block. If necessary, re-secure the faulty connections.</p> <p>Energize system after the above steps have been completed. If control still reads "000", call service technician.</p>
<p>2. Control displays "CCC".</p>	<p>A. Sensor is short circuited.</p> <p>B. Associated wiring is short circuited.</p> <p>C. Control is faulty.</p>	<p>Detach the sensor from the terminal block. Use an Ohm meter to measure the resistance of the sensor. Check sensor at 32°F (0°C) using a container of ice water. If Ohm reading is 100, replace display. If Ohm reading is not 100, replace sensor.</p> <p>Check wires for integrity. Check for proper and secure connections at the thermostat and terminal block. If necessary, re-secure the faulty connections.</p> <p>Energize system after the above steps have been completed. If control still reads "CCC", call service technician.</p>
<p>3. Unit does not operate.</p>	<p>A. Insufficient power supply.</p> <p>B. Defective power cord or plug.</p>	<p>Check power source.</p> <p>Check and replace if necessary.</p>
<p>4. No display in electronic control.</p>	<p>A. Faulty power supply board.</p> <p>B. Faulty electronic control</p>	<p>Check line voltage for 24V across pins 6 and 7 on the power supply board.</p> <p>Replace control.</p>
<p>5. Cannot control temperature but sensor and electronic control check OK.</p>	<p>A. Faulty relay.</p> <p>B. Heating element sensor.</p>	<p>Replace relay.</p> <p>Replace element.</p>
<p>6. Temperature readout incorrect.</p>	<p>A. Dirty or faulty sensor.</p> <p>B. Faulty control.</p>	<p>Detach the sensor from the terminal block. Use an Ohm meter to measure the resistance of the sensor. Check sensor at 32°F (0°C) using a container of ice water. If Ohm reading is 100, replace display. If Ohm reading is not 100, replace sensor.</p>

**DISCONNECT UNIT FROM POWER SOURCE
BEFORE CLEANING OR SERVICING.**



SERVICE VIEW PARTS LIST

750-GDU — REACH-IN

8/27/02	Description	Quantity per Unit	A/S Part Number
1.	TOP	1	11559
2.	TOP MOUNTING SCREWS	2	SC-2425
3.	CASTER BRACKET	2	4974
4.	CASTER BRACKET MOUNTING SCREWS	8	SC-2425
5.	CORD, 125V	1	CD-33367
	CORD, 230V	1	CD-3922
	BUSHING	1	BU-3011
6.	CASING, BOTTOM	1	14523
	CASING, RIGHT-HAND	1	14332
	CASING, LEFT-HAND	1	14333
7.	CASING MOUNTING SCREWS	6	SC-2425
8.	INSULATION: 25" x 120" (635mm x 3048mm)	1	IN-22364
9.	CABLE CONNECTION HARDWARE		
10.	HEATING CABLE: Length 144' (43891mm)	1	CB-3045
11.	THERMOSTAT	1	TT-3057
	— THERMOSTAT KNOB, Fahrenheit	1	KN-3469
	— THERMOSTAT KNOB, Celsius	1	KN-3474
12.	TEMPERATURE GAUGE	1	GU-3273
13.	HEAT INDICATOR LIGHT, 125V	1	LI-3493
	HEAT INDICATOR LIGHT, 230V	1	LI-3923
14.	LIGHT SWITCH	1	SW-3887
15.	BULB, 125V	2	LP-3480
	BULB, 230V	2	LP-3606
16.	BULB SOCKET, 125V	2	RP-3952
	BULB SOCKET, 230V	2	RP-3955
17.	GLASS DOOR, Left-hand	1	4972
18.	GLASS DOOR, Right-hand	1	4973
	<u>EACH DOOR INCLUDES:</u>		
	— TOP DOOR HINGE	1	HG-2892
	— BOTTOM DOOR HINGE	1	HG-23952
	— TOP HINGE PIVOT PIN	1	PI-2894
	— BOTTOM HINGE PIVOT PIN	1	PI-23953
	— HANDLE	1	HD-2910
	— HANDLE MOUNTING SCREWS	2	SC-2911
	— DOOR GASKET: Length 6.3' (1920mm)	1	GS-2891
19.	GLASS, BACK (REAR)	1	4971
20.	DOOR LATCH	2	LT-23187
21.	SIDE RACK, LEFT-HAND	1	SR-2849
	SIDE RACK, RIGHT-HAND	1	SR-2850
22.	SHELF	3	SH-2851
23.	BIMET THERMOSTAT, 230V ONLY	1	TT-3859
24.	FILTER (LINE)	1	FI-33225
	FILTER BRACKET	1	13001
25.	FUSEHOLDER	1	FU-3884
	FUSE	1	FU-3883

SERVICE VIEW • PAGE 8

SERVICE VIEW PARTS LIST

750-GDU/PT — PASS-THRU

8/27/02	Description	Quantity per Unit	A/S Part Number
1.	TOP	1	11559
2.	TOP MOUNTING SCREWS	2	SC-2425
3.	CASTER BRACKET	2	4974
4.	CASTER BRACKET MOUNTING SCREWS	8	SC-2425
5.	CORD, 125V	1	CD-33367
	CORD, 230V	1	CD-3922
	BUSHING	1	BU-3011
6.	CASING, BOTTOM	1	14523
	CASING, RIGHT HAND	1	14332
	CASING, LEFT HAND	1	14333
7.	CASING MOUNTING SCREWS	6	SC-2425
8.	INSULATION: 25" x 120" (635mm x 3048mm)	1	IN-22364
9.	CABLE CONNECTION HARDWARE		
10.	HEATING CABLE: Length 144' (43891mm)	1	CB-3045
11.	THERMOSTAT	1	TT-3057
	— THERMOSTAT KNOB, Fahrenheit	1	KN-3469
	— THERMOSTAT KNOB, Celsius	1	KN-3474
12.	TEMPERATURE GAUGE	1	GU-3273
13.	HEAT INDICATOR LIGHT, 125V	1	LI-3493
	HEAT INDICATOR LIGHT, 230V	1	LI-3923
14.	LIGHT SWITCH	1	SW-3887
15.	BULB, 125V	2	LP-3480
	BULB, 230V	2	LP-3606
16.	BULB SOCKET, 125V	2	RP-3952
	BULB SOCKET, 230V	2	RP-3955
17.	GLASS DOOR, Left-hand	2	4972
18.	GLASS DOOR, Right-hand	2	4973
	<u>EACH DOOR INCLUDES:</u>		
	— TOP DOOR HINGE	1	HG-2892
	— BOTTOM DOOR HINGE	1	HG-23952
	— TOP HINGE PIVOT PIN	1	PI-2894
	— BOTTOM HINGE PIVOT PIN	1	PI-23953
	— HANDLE	1	HD-2910
	— HANDLE MOUNTING SCREWS	2	SC-2911
	— DOOR GASKET: Length 6.3' (1920mm)	1	GS-2891
19.	DOOR LATCH	4	LT-23187
20.	SIDE RACK	2	SR-2213
21.	SHELF	3	SH-2114
22.	BIMET THERMOSTAT, 230V only	1	TT-3859
23.	FILTER (LINE)	1	FI-33225
	FILTER BRACKET	1	13001
24.	FUSEHOLDER	1	FU-3884
	FUSE	1	FU-3883

SERVICE VIEW • PAGE 9

Heating Cable Replacement Service Kit

No.4881

<small>includes:</small>		
CB-3045	Cable Heating Element	.210 feet
CR-3226	Ring Connector	.12
IN-3488	Insulation Corner	.1 foot
BU-3105	Shoulder Bushing	.12
BU-3106	Cup Bushing	.12
SL-3063	Insulating Sleeve	.12
TA-3540	Electrical Tape	.1 roll
ST-2439	Stud, 10-32	.12
NU-2215	Hex Nut, 10-32	.24

OPTIONS & ACCESSORIES

Casters, 5" (127mm)	4007
Legs, 6" (152mm)	5205
Stacking Kit	5001359
Wire Pan Grid	PN-2115
Wire Shelves	
— Reach-In	SH-2851
— Pass-Through	SH-2114

SERVICE VIEW PARTS LIST

750-GDU/MET — REACH-IN

5/20/03	DESCRIPTION	QUANTITY PER UNIT	A/S PART NUMBER
1.	TOP ASSEMBLY	1	14254
2.	TOP MOUNTING SCREWS	4	SC-2425
3.	BULB (NOT SHOWN)	6	LP-33268
4.	BULB ASSEMBLY	6	LP-33267
5.	TRANSFORMER	1	TN-33266
6.	RELAY	1	RL-3736
7.	FUSE HOLDER	1	FU-3772
	- FUSE 4 AMP	2	FU-33287
8.	CABLE CONNECTION HARDWARE		
9.	TIMERS	6	TR-33265
10.	POWER SWITCH	1	SW-3887
11.	THERMOSTAT, 125V, 230V	1	TT-33563
12.	PANEL OVERLAY	1	PE-23544
	FRONT PANEL OVERLAY	1	PE-22133
13.	DOOR LATCH	2	LT-23187
14.	GLASS DOOR:		
	- LEFT HAND	1	4972
	- RIGHT HAND	1	4973
	EACH DOOR INCLUDES:		
	- TOP DOOR HINGE	2	HG-2892
	- BOTTOM DOOR HINGE	2	HG-23952
	- TOP DOOR PIVOT PIN	1	PI-2894
	- BOTTOM DOOR PIVOT PIN	1	PI-23953
	- HANDLE	1	HD-2910
	- HANDLE MOUNTING SCREWS	2	SC-2911
	- MAGNETIC CATCH	1	LT-24123
	- DOOR GASKET ASSEMBLY	1	GS-2891
15.	SIDE RACK:		
	- LEFT HAND	1	SR-2849
	- RIGHT HAND	1	SR-2850
16.	SHELF	3	SH-2851
17.	SENSOR	1	SN-33541
	SENSOR BLOCK	1	BK-24427
	SENSOR GUARD	1	1496
	SENSOR MOUNTING SCREWS	2	SC-2239
18.	FILTER, 230V ONLY (NOT SHOWN)	1	FI-33225
	FILTER STANDOFF, 230V ONLY	1	13001
	FILTER MOUNTING SCREWS, 230V ONLY	2	SC-2425
19.	CORD - 125V ONLY	1	CD-33367
	- 230V ONLY	1	CD-3922
20.	DRIP PAN, GASTRONORM, 230V ONLY	1	PN-23166
21.	LEFT HAND CASING	1	14573
	RIGHT HAND CASING	1	14572
	BOTTOM CASING ASSEMBLY	1	14523
	BOTTOM CASING MOUNTING SCREWS	6	SC-2425
22.	CASTER BRACKET ASSEMBLY	2	4974
23.	CASTER BRACKET MOUNTING SCREWS	8	SC-2425
24.	OPTIONAL: SWIVEL CASTER W/BRAKE	2	CS-2026
	MOUNTING SCREWS	8	SC-2351
25.	OPTIONAL: CASTER, RIGID	2	CS-2025
	MOUNTING SCREWS	8	SC-2351
27.	FAN:		
	- 125V ONLY	1	FA-3973
	- 230V ONLY	1	FA-3974
	- MOUNTING SCREWS	4	SC-2661
28.	INSULATION: 25" X 120" (635mm x 3048mm)	1	IN-22364
29.	HEATING CABLE: LENGTH, 144'	1	CB-3045
30.	REAR GLASS ASSEMBLY	1	4971

SERVICE VIEW PARTS LIST

750-GDU/MET/PT — PASS-THRU

5/20/03	DESCRIPTION	QUANTITY PER UNIT	A/S PART NUMBER
1.	TOP ASSEMBLY	1	14254
2.	TOP MOUNTING SCREWS	4	SC-2425
3.	BULB (NOT SHOWN)	6	LP-33268
4.	BULB ASSEMBLY	6	LP-33267
5.	TRANSFORMER	1	TN-33266
6.	RELAY	1	RL-3736
7.	FUSE HOLDER	1	FU-3772
	- FUSE 4 AMP	2	FU-33287
8.	CABLE CONNECTION HARDWARE		
9.	TIMERS	6	TR-33265
10.	POWER SWITCH	1	SW-3887
11.	THERMOSTAT, 125V, 230V	1	TT-33563
12.	PANEL OVERLAY	1	PE-23544
	FRONT PANEL OVERLAY	1	PE-22133
13.	DOOR LATCH	2	LT-23187
14.	GLASS DOOR:		
	- LEFT HAND	2	4972
	- RIGHT HAND	2	4973
	EACH DOOR INCLUDES:		
	- TOP DOOR HINGE	2	HG-2892
	- BOTTOM DOOR HINGE	2	HG-23952
	- TOP DOOR PIVOT PIN	1	PI-2894
	- BOTTOM DOOR PIVOT PIN	1	PI-23953
	- HANDLE	1	HD-2910
	- HANDLE MOUNTING SCREWS	2	SC-2911
	- MAGNETIC CATCH	1	LT-24123
	- DOOR GASKET ASSEMBLY	1	GS-2891
15.	SIDE RACK	2	SR-2213
16.	SHELF	3	SH-2114
17.	SENSOR	1	SN-33541
	SENSOR BLOCK	1	BK-24427
	SENSOR GUARD	1	1496
	SENSOR MOUNTING SCREWS	2	SC-2239
18.	CORD - 125V ONLY	1	CD-33367
19.	LEFT HAND CASING	1	14573
	RIGHT HAND CASING	1	14572
	BOTTOM CASING ASSEMBLY	1	14523
	BOTTOM CASING MOUNTING SCREWS	6	SC-2425
20.	CASTER BRACKET ASSEMBLY	2	4974
21.	CASTER BRACKET MOUNTING SCREWS	8	SC-2425
22.	OPTIONAL: SWIVEL CASTER W/BRAKE	2	CS-2026
	MOUNTING SCREWS	8	SC-2351
23.	OPTIONAL: CASTER, RIGID	2	CS-2025
	MOUNTING SCREWS	8	SC-2351
24.	FAN:		
	- 125V ONLY	1	FA-3973
	- MOUNTING SCREWS	4	SC-2661
25.	INSULATION: 25" X 120" (635mm x 3048mm)	1	IN-22364
26.	HEATING CABLE: LENGTH, 144'	1	CB-3045

SERVICE VIEW • NOT SHOWN

▶ *When replacing bulbs -- be careful not to over-tighten.*

750-GDU
SERVICE VIEW REV: 09/09/02 CJB
SCALE: 3/32=1"

IENG\PRODA\SM\GDU.DWG

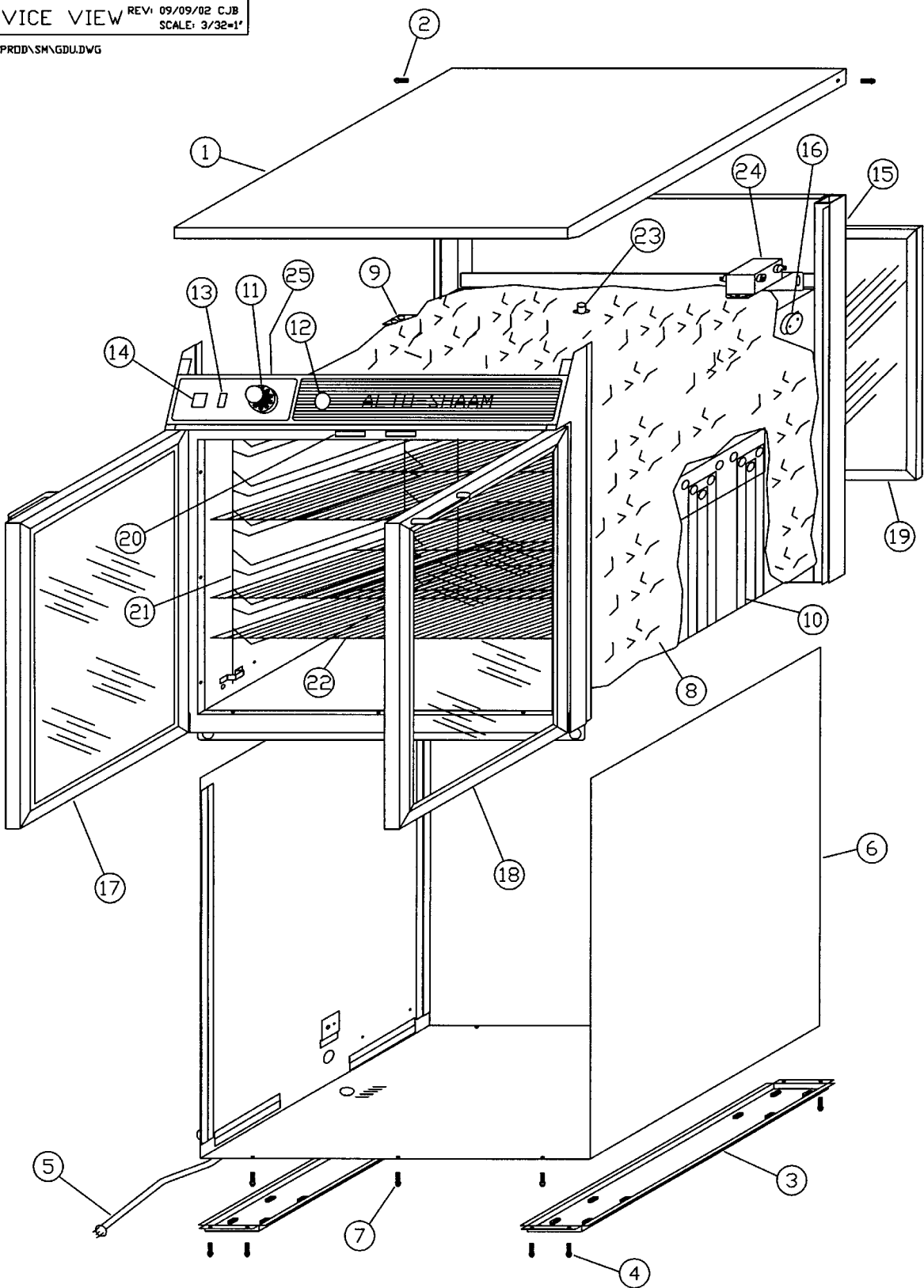

7-5-89

750-GDU/MET
SERVICE VIEW

3/32*1

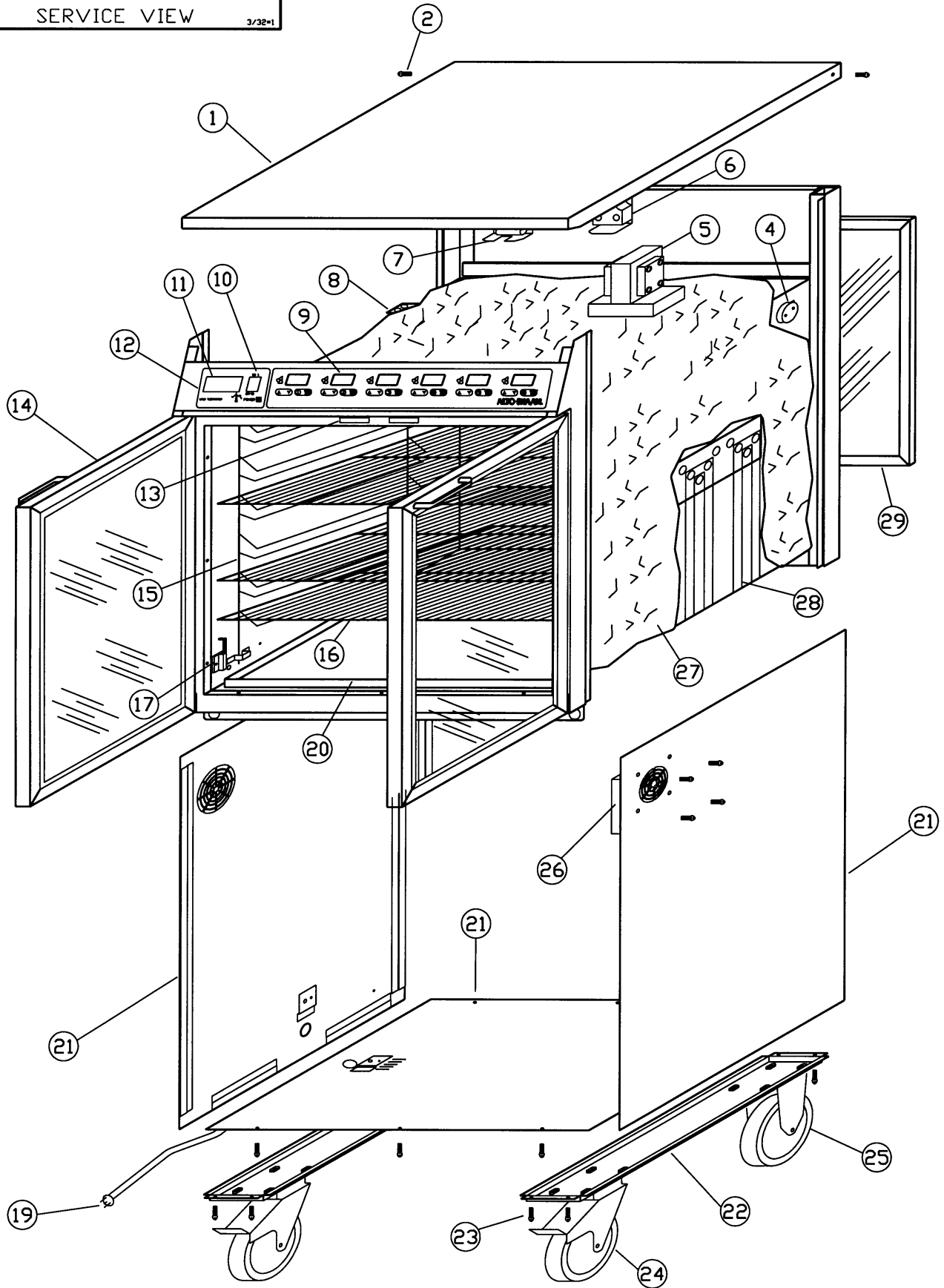

ENG\PRODSM\GDMET.DWG

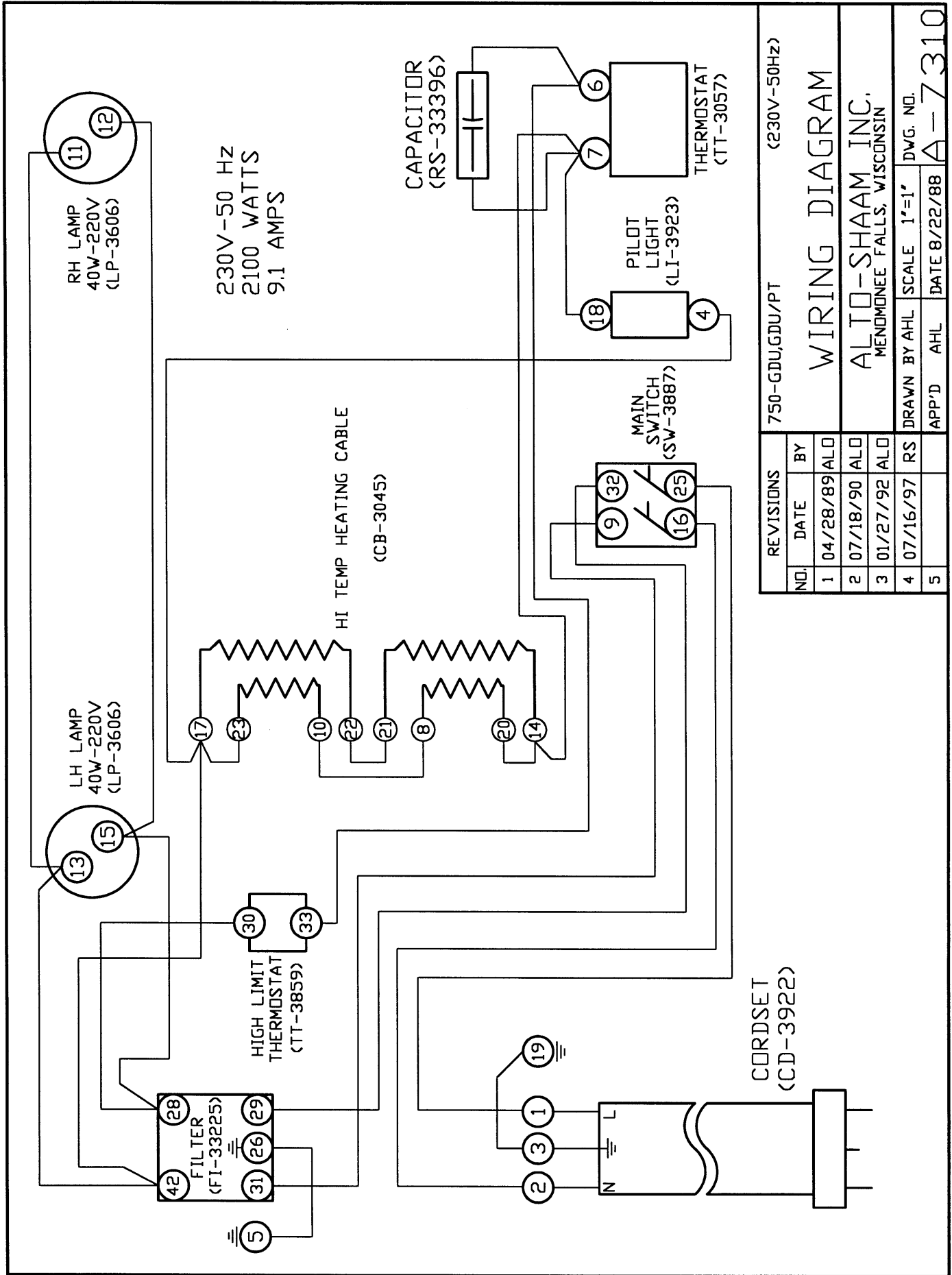

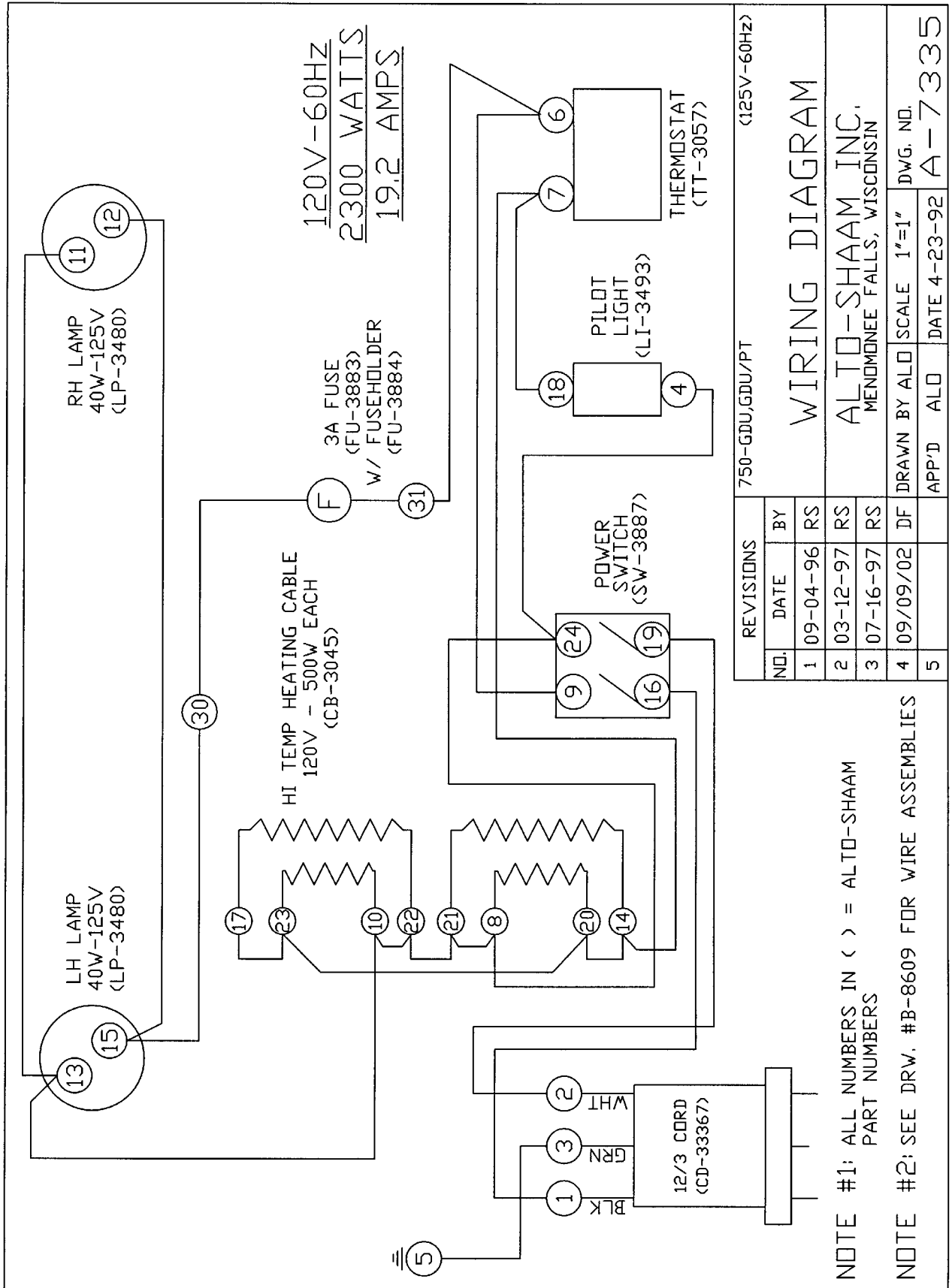

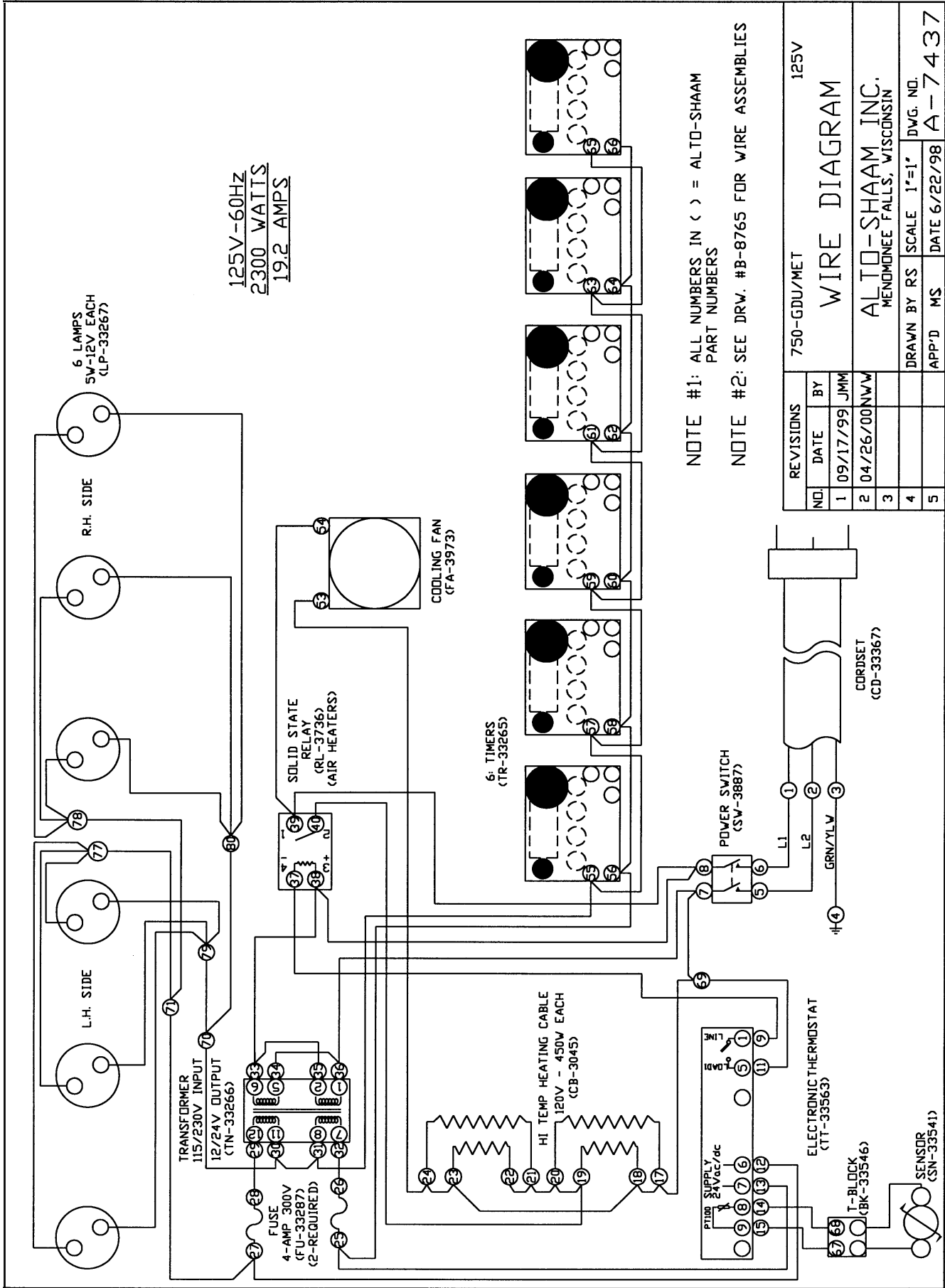

NOTE #1: ALL NUMBERS IN () = ALTO-SHAAM PART NUMBERS

NOTE #2: SEE DRW. #B-8765 FOR WIRE ASSEMBLIES

NO.	REVISIONS	DATE	BY
1		09/17/99	JMM
2		04/26/00	NW
3			
4			
5			

750-GDU/MET 125V

WIRE DIAGRAM

ALTO-SHAAM, INC.
MEMMONEE FALLS, WISCONSIN

DRAWN BY	RS	SCALE	1"=1'	DWG. NO.	A-7437
APP'D	MS	DATE	6/22/98		

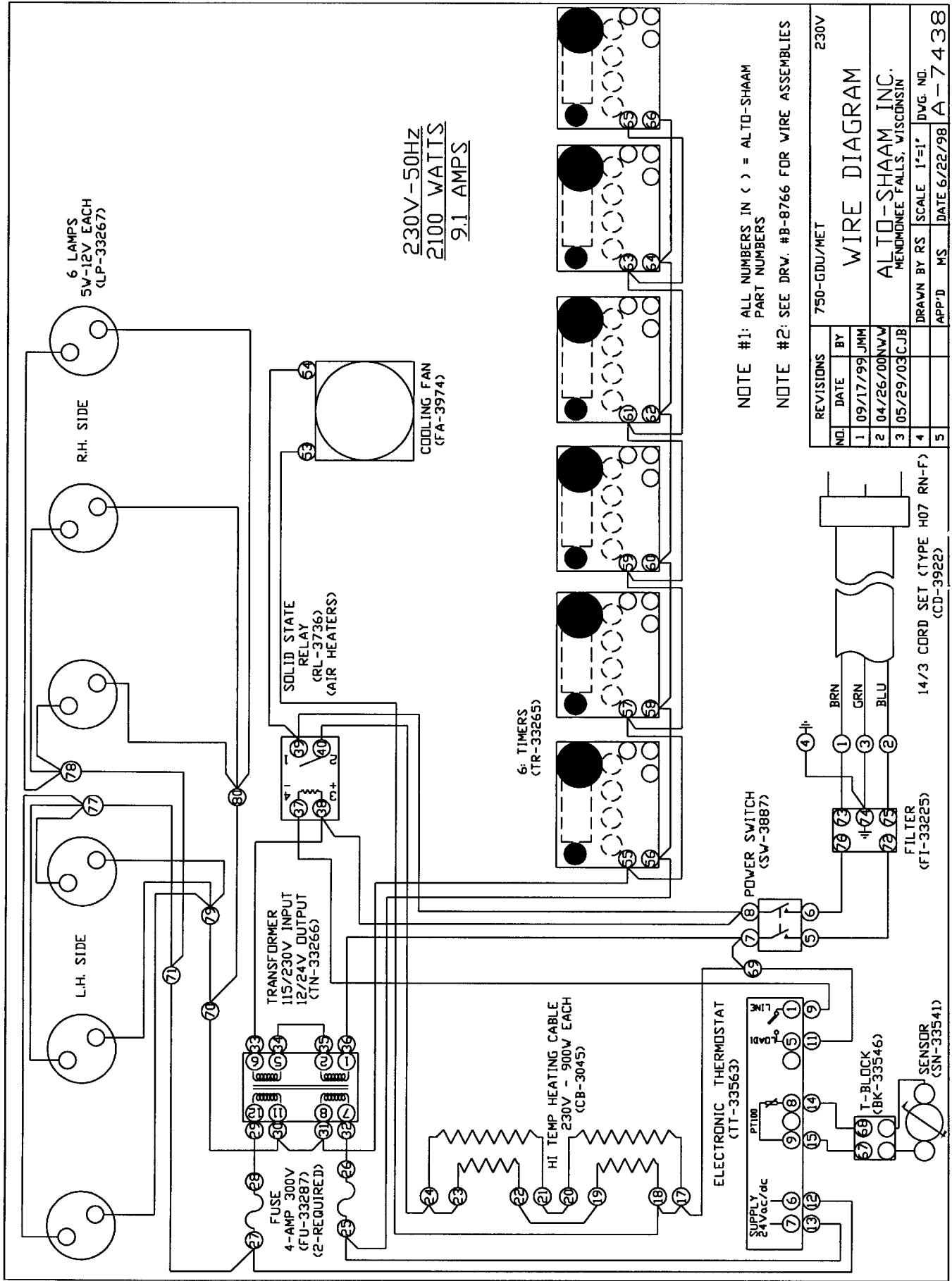

NOTE #1: ALL NUMBERS IN () = ALTO-SHAAM PART NUMBERS

NOTE #2: SEE DRW. #B-8766 FOR WIRE ASSEMBLIES

NO.	DATE	BY	REVISIONS
1	09/17/99	JMM	750-GDU/MET
2	04/26/00	NW	
3	05/29/03	CJB	
4			
5			

WIRE DIAGRAM

ALTO-SHAAM INC.
MEMONEE FALLS, WISCONSIN

APP'D MS. DATE 6/22/98 A-7438

DRAWN BY RS SCALE 1"=1' DVG. NO.

TRANSPORTATION DAMAGE and CLAIMS



All Alto-Shaam equipment is sold F.O.B. shipping point, and when accepted by the carrier, such shipments become the property of the consignee.

Should damage occur in shipment, it is a matter between the carrier and the consignee. In such cases, the carrier is assumed to be responsible for the safe delivery of the merchandise, unless negligence can be established on the part of the shipper.

1. Make an immediate inspection while the equipment is still in the truck or immediately after it is moved to the receiving area. Do not wait until after the material is moved to a storage area.
2. Do not sign a delivery receipt or a freight bill until you have made a proper count and inspection of all merchandise received.
3. Note all damage to packages directly on the carrier's delivery receipt.
4. Make certain the driver signs this receipt. If he refuses to sign, make a notation of this refusal on the receipt.
5. If the driver refuses to allow inspection, write the following on the delivery receipt:
Driver refuses to allow inspection of containers for visible damage.
6. Telephone the carrier's office immediately upon finding damage, and request an inspection. Mail a written confirmation of the time, date, and the person called.
7. Save any packages and packing material for further inspection by the carrier.
8. Promptly file a written claim with the carrier and attach **copies** of all supporting paperwork.

We will continue our policy of assisting our customers in collecting claims which have been properly filed and actively pursued. We cannot, however, file any damage claims for you, assume the responsibility of any claims, or accept deductions in payment for such claims.

ALTO-SHAAM® LIMITED WARRANTY

Alto-Shaam, Inc. warrants to the original purchaser that any original part that is found to be defective in material or workmanship will, at our option, subject to provisions hereinafter stated, be replaced with a new or rebuilt part.

The labor warranty remains in effect one (1) year from installation or fifteen (15) months from the shipping date, whichever occurs first.

The parts warranty remains in effect one (1) year from installation or fifteen (15) months from the shipping date, whichever occurs first.

Exceptions to the one year part warranty period are as listed:

- A. Halo Heat cook/hold ovens include a five (5) year parts warranty on the heating element. Labor will be covered under the terms of the standard warranty period of one (1) year or fifteen (15) months.
- B. Alto-Shaam Quickchillers include a five (5) year parts warranty on the refrigeration compressor. Labor will be covered under the terms of the standard warranty period of one (1) year or fifteen (15) months.

This warranty does not apply to:

1. Calibration
2. Replacement of light bulbs and/or the replacement of display case glass due to damage of any kind.
3. Equipment damage caused by accident, shipping, improper installation or alteration.
4. Equipment used under conditions of abuse, misuse, carelessness or abnormal conditions.
5. Any losses or damage resulting from malfunction, including loss of product or consequential or incidental damages of any kind.
6. Equipment modified in any manner from original model, substitution of parts other than factory authorized parts, removal of any parts including legs, or addition of any parts.

This warranty is exclusive and is in lieu of all other warranties, expressed or implied, including the implied warranties of merchantability and fitness for purpose. In no event shall the Company be liable for loss of use, loss of revenue, or loss of product or profit, or for indirect or consequential damages.

This warranty is in lieu of all other warranties expressed or implied and Alto-Shaam, Inc. neither assumes or authorizes any persons to assume for it any other obligation or liability in connection with Alto-Shaam equipment.

ALTO-SHAAM, INC.

Warranty effective January 1, 2000

Record the model and serial numbers of the unit for easy reference. Always refer to both model and serial number in your correspondence regarding the unit.

Model: _____
Serial Number: _____
Purchased From: _____
Date Installed: _____ Voltage: _____

HALO HEAT COOK/HOLD/SERVE SYSTEMS BY ALTO-SHAAM®

W164 N9221 Water Street • P.O. Box 450 • Menomonee Falls, Wisconsin 53052-0450 • U.S.A.

PHONE: 262.251.3800

FAX: 262.251.7067 • 800.329.8744 U.S.A./CANADA

WEBSITE:

800.558.8744 U.S.A./CANADA

262.251.1907 INTERNATIONAL

www.alto-shaam.com