

ALTO SHAAM®

FRYER DUMP STATION



MODELS
ASF-75DS
ASF-60DS

- **INSTALLATION**
- **OPERATION**
- **MAINTENANCE**



W164 N9221 Water Street • P.O. Box 450 • Menomonee Falls, Wisconsin 53052-0450 USA
PHONE: 262.251.3800 • 800.558.8744 USA/CANADA FAX: 262.251.7067 • 800.329.8744 U.S.A. ONLY
www.alto-shaam.com

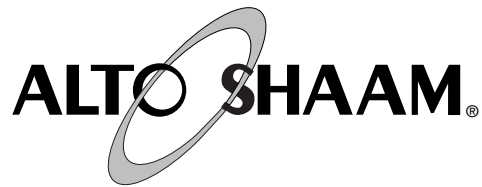

DELIVERY

This Alto-Shaam appliance has been thoroughly tested and inspected to insure only the highest quality unit is provided. Upon receipt, check for any possible shipping damage and report it at once to the delivering carrier. *See Transportation Damage and Claims section located in this manual.*

This appliance, complete with unattached items and accessories, may have been delivered in one or more packages. Check to ensure that all standard items and options have been received with each model as ordered.

Save all the information and instructions packed with the appliance. Complete and return the warranty card to the factory as soon as possible to assure prompt service in the event of a warranty parts and labor claim.

This manual must be read and understood by all people using or installing the equipment model. Contact the Alto-Shaam service department if you have any questions concerning installation, operation, or maintenance.

NOTE: All claims for warranty must include the full model number and serial number of the unit.

UNPACKING

1. Carefully remove the appliance from the carton or crate.

NOTE: Do not discard the carton and other packaging material until you have inspected the unit for hidden damage and tested it for proper operation.

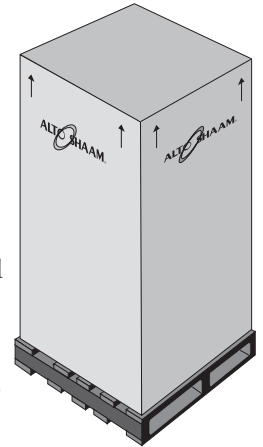

2. Read all instructions in this manual carefully before initiating the installation of this appliance.

DO NOT DISCARD THIS MANUAL.

This manual is considered to be part of the appliance and is to be provided to the owner or manager of the business or to the person responsible for training operators. *Additional manuals are available from the Alto-Shaam service department.*

3. Remove all protective plastic film, packaging materials, and accessories from the appliance before connecting electrical power. Store any accessories in a convenient place for future use.

SAFETY PROCEDURES AND PRECAUTIONS

Knowledge of proper procedures is essential to the safe operation of electrically and/or gas energized equipment. In accordance with generally accepted product safety labeling guidelines for potential hazards, the following signal words and symbols may be used throughout this manual.

DANGER	
	Used to indicate the presence of a hazard that WILL cause severe personal injury, death, or substantial property damage if the warning included with this symbol is ignored.

WARNING	
	Used to indicate the presence of a hazard that CAN cause personal injury, possible death, or major property damage if the warning included with this symbol is ignored.

CAUTION	
	Used to indicate the presence of a hazard that can or will cause minor or moderate personal injury or property damage if the warning included with this symbol is ignored.

CAUTION	
Used to indicate the presence of a hazard that can or will cause minor personal injury, property damage, or a potential unsafe practice if the warning included with this symbol is ignored.	

NOTE: Used to notify personnel of installation, operation, or maintenance information that is important but not hazard related.

1. This appliance is intended to cook, hold or process foods for the purpose of human consumption. No other use for this appliance is authorized or recommended.
2. This appliance is intended for use in commercial establishments where all operators are familiar with the purpose, limitations, and associated hazards of this appliance. Operating instructions and warnings must be read and understood by all operators and users.
3. Any troubleshooting guides, component views, and parts lists included in this manual are for general reference only and are intended for use by qualified technical personnel.
4. This manual should be considered a permanent part of this appliance. This manual and all supplied instructions, diagrams, schematics, parts lists, notices, and labels must remain with the appliance if the item is sold or moved to another location.

NOTE	
	For equipment delivered for use in any location regulated by the following directive: DO NOT DISPOSE OF ELECTRICAL OR ELECTRONIC EQUIPMENT WITH OTHER MUNICIPAL WASTE.

SPECIFICATIONS

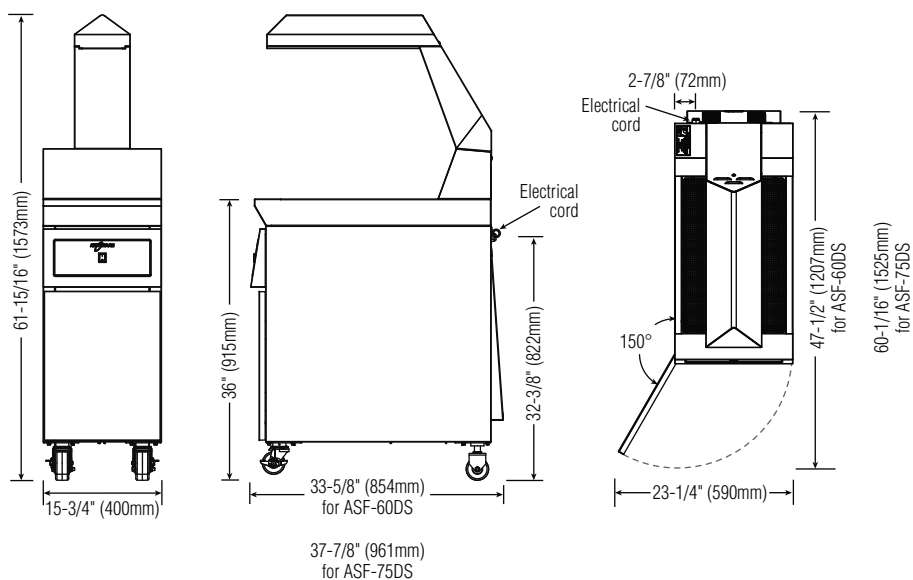

DIMENSIONS EXTERIOR H x W x D:	
ASF-60DS	61-15/16" x 15-3/4" x 33-5/8" (1573mm x 400mm x 854mm) 36" (915mm) unit height without infrared warmer
ASF-75DS	61-15/16" x 15-3/4" x 37-7/8" (1573mm x 400mm x 961mm) 36" (915mm) unit height without infrared warmer

CAPACITY
18 lb (8.2 kg) MAXIMUM

WEIGHT EST.	NET WEIGHT	SHIP WEIGHT
	CONTACT FACTORY	CONTACT FACTORY
CARTON DIMENSIONS:	CONTACT FACTORY	

INSTALLATION

DANGER



IMPROPER INSTALLATION, ALTERATION, ADJUSTMENT, SERVICE, OR MAINTENANCE COULD RESULT IN SEVERE INJURY, DEATH OR CAUSE PROPERTY DAMAGE.

READ THE INSTALLATION, OPERATING AND MAINTENANCE INSTRUCTIONS THOROUGHLY BEFORE INSTALLING OR SERVICING THIS EQUIPMENT.

DANGER



AVERTISSEMENT : UNE INSTALLATION, UN AJUSTEMENT, UNE ALTÉRATION, UN SERVICE OU UN ENTRETIEN NON CONFORME AUX NORMES PEUT CAUSER DES DOMMAGES À LA PROPRIÉTÉ, DES BLESSURES OU LA MORT.

LIRE ATTENTIVEMENT LES DIRECTIVES D'OPÉRATION ET D'ENTRETIEN AVANT DE FAIRE L'INSTALLATION, OU L'ENTRETIEN DE CET ÉQUIPEMENT.

CAUTION

DO NOT USE FORKLIFT FROM FRONT OR REAR OF UNIT.
USE FORKLIFT FROM SIDE ONLY.

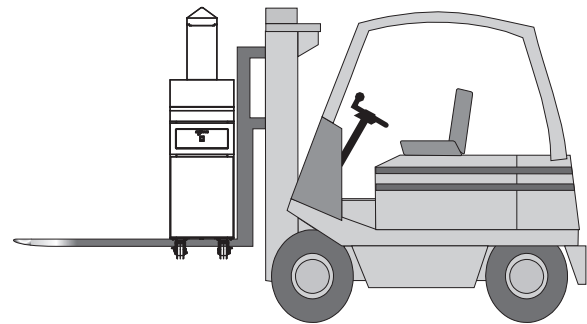

MINIMUM CLEARANCE REQUIREMENTS

	COMBUSTIBLE SURFACES	NON-COMBUSTIBLE SURFACES
RIGHT SIDE	6" (152mm)	0" (0mm)
LEFT SIDE	6" (152mm)	0" (0mm)
BACK	6" (152mm)	6" (152mm)
FRONT	25" (635mm)	
ENTRY CLEARANCE: 30" (762mm) uncrated		

Ne pas installer à une distance inférieure à celle indiquée ce-dessous d'une paroi en matière combustible: Côtés 6 pouces, Arrière 6 pouces.

WARNING

MINIMUM CLEARANCES MUST REMAIN UNOBSTRUCTED.
DO NOT place insulation or any other type of materials in clearance areas.

INSTALLATION

1. It is the responsibility of the installer to verify that this dump station installation is in compliance with the specifications listed in this manual and with local code requirements.
2. Both holding and cleaning functions require unobstructed access. The control panel must be maintained free from obstruction.
3. Locate the dump station on a firm, level surface ONLY. The area surrounding the dump station must be kept clear of all combustible materials.
4. **FOR YOUR SAFETY DO NOT** store or use any flammable liquids or allow flammable vapors in the vicinity of this dump station or any other appliance.
5. **FOR YOUR SAFETY DO NOT** place insulation or any other type of materials in clearance areas.
6. When properly installed, the dump station is designed for operation adjacent to non-combustible floors and walls with a 6" clearance at the back. Clearances from all combustible construction is a minimum of 6" (152mm) at the back and both sides. Concrete, tile, terrazzo, or metal surfaces are recommended. Metal over a combustible material may not meet code for non-combustible surfaces. Verify site selection with local codes for specific requirements.
Doit être utilisé seulement sur des planchers non inflammables.
7. Adequate means must be provided to limit the movement of this appliance. A restraining device is required for field installation.
8. DO NOT install this dump station in any area where it may be affected by any adverse conditions such as steam or dripping water, etc. DO NOT install the dump station over a drain.

9. **LEVELING:** Make certain the fryer is positioned firmly on all four supporting casters. Level fryer front-to-back and side-to-side by holding lower collar (#2) while twisting upper collar (#1). Restraining ties can be used for stabilization if necessary. Use an allen wrench (#3) to lock caster in position.

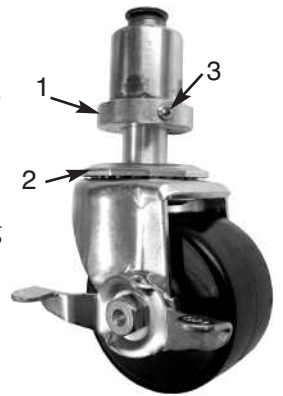

CAUTION



**TO PREVENT PERSONAL INJURY,
USE CAUTION WHEN MOVING OR
LEVELING THIS APPLIANCE.**

WARNING



**IMPROPER INSTALLATION
MAY RESULT IN FIRE.**
Carefully read and follow all installation
instructions located in this manual.



WARNING



RISK OF ELECTRIC SHOCK.

**Appliance must be secured
to building structure.**

INSTALLATION

VENTILATION:



DANGER

Installation, air ventilation requirements, and service work must be in accordance with all local codes and must be performed by a qualified service technician.

An adequate ventilation system is required for commercial cooking equipment. Information may be obtained by writing to the National Fire Protection Association, Batterymarch Park, Quincy, MA 02269. When writing refer to NFPA No. 96.

Ventilating hoods and exhaust systems shall be permitted to be used to vent appliances installed in commercial applications.

Where automatically operated appliances are vented through a ventilating hood or exhaust system equipped with a damper or with a power means of exhaust, provisions shall be made to allow the flow of gas to the main burners only when the damper is open to a position to properly vent the appliance and when the power means of exhaust is in operation. IN ACCORDANCE WITH NFPA 54 COMMONWEALTH OF MASSACHUSETTS ONLY.

ELECTRICAL REQUIREMENTS

1. An identification tag is permanently mounted on the dump station.

DANGER

**ENSURE POWER SOURCE
MATCHES VOLTAGE STAMPED
ON APPLIANCE NAMEPLATE.**

2. Plug the unit into a properly grounded receptacle ONLY. Arcing will occur when connecting or disconnecting the unit unless power switch is in the "OFF" position.
3. Position the unit so the cord is easily accessible in case of any emergencies. If necessary, a proper receptacle or outlet configuration as required for the unit must be installed by a licensed electrician in accordance with applicable, local electrical codes.

DANGER

**ELECTRICAL CONNECTIONS MUST
BE MADE BY A QUALIFIED SERVICE
TECHNICIAN IN ACCORDANCE WITH
APPLICABLE ELECTRICAL CODES.**

230V:

To prevent an electrical shock hazard between the appliance and other appliances or metal parts in close vicinity, an equalization-bonding stud is provided. An equalization bonding lead must be connected to this stud and the other appliances / metal parts to provide sufficient protection against potential difference. The terminal is marked with the following symbol.



NOTE: The appliance must be connected to an electrical circuit that is protected by an external GFCI outlet.

DANGER

To avoid electrical shock, this appliance MUST be adequately grounded in accordance with local electrical codes or, in the absence of local codes, with the current edition of the National Electrical Code ANSI/NFPA No. 70. In Canada, all electrical connections are to be made in accordance with CSA C22.1, Canadian Electrical Code Part 1 or local codes.

CAUTION

IF THE SUPPLY CORD IS DAMAGED IT MUST BE REPLACED BY A QUALIFIED SERVICE TECHNICIAN TO AVOID A SAFETY HAZARD.

ELECTRICAL • ASF-60DS & ASF-75DS						
VOLTAGE	PHASE	CYCLE/HZ	AMPS	kW	CORD & PLUG	
120	1	60	8.4	1.0		NEMA 5-15P 15A-125V PLUG 8' CORD
230	1	50	4.4	1.0		CEE 7/7 16A-250V PLUG 9' CORD

OPERATING INSTRUCTIONS

PANEL IDENTIFICATION

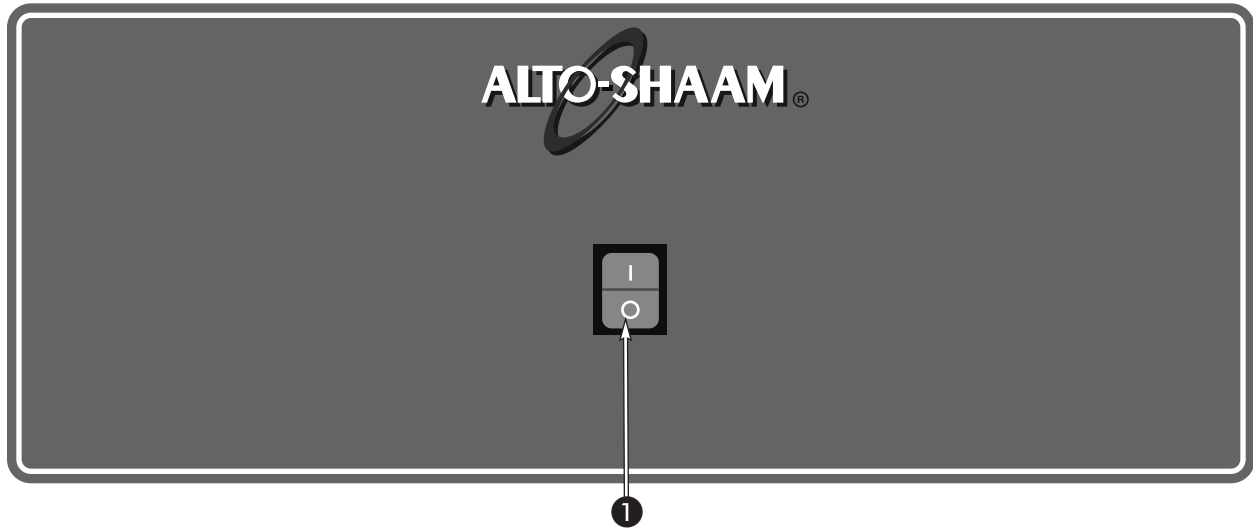

CONTROL PANEL IDENTIFICATION

1. ON/OFF TOGGLE SWITCH

1. Press ON/OFF toggle switch to power on the unit. The overhead infrared warming lamp will turn on and begin to heat dump station pan.
2. Unit will take 15-20 minutes to fully heat. Fill with load (18 lbs. maximum).

CAUTION



METAL PARTS OF THIS EQUIPMENT BECOME EXTREMELY HOT WHEN IN OPERATION. TO AVOID BURNS, ALWAYS USE HAND PROTECTION WHEN OPERATING THIS APPLIANCE.

CARE AND CLEANING

CLEANING & MAINTENANCE

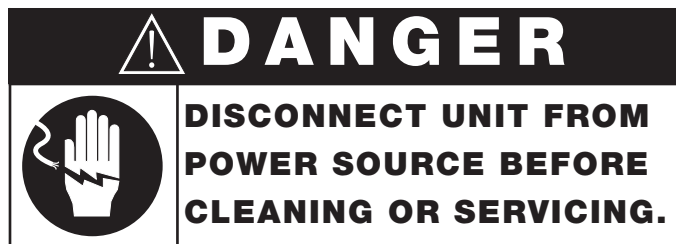

THOROUGHLY CLEAN DAILY

The cleanliness and appearance of this unit will contribute considerably to operating efficiency and savory, appetizing food. Good equipment kept clean works better and lasts longer.

1. Disconnect unit from power source and let cool.
2. Remove all detachable items including holding well tray and crumb drawer behind front door. Clean these items separately with a good grease solvent or commercial detergent. Rinse well and dry.
3. Clean control panel thoroughly since this area harbors food debris. Rinse by wiping with sponge and clean warm water. Wipe dry with a clean cloth.

4. To help maintain the protective film coating on polished stainless steel, clean the exterior of the unit with a cleaner recommended for stainless steel surfaces. Spray the cleaning agent on a clean cloth and wipe with the grain of the stainless steel.

NOTE: Avoid the use of abrasive cleaning compounds, chloride based cleaners, or cleaners containing quaternary salts. Never use hydrochloric acid (muriatic acid) on stainless steel.

Always follow appropriate state or local health (hygiene) regulations regarding all applicable cleaning and sanitation requirements for foodservice equipment.

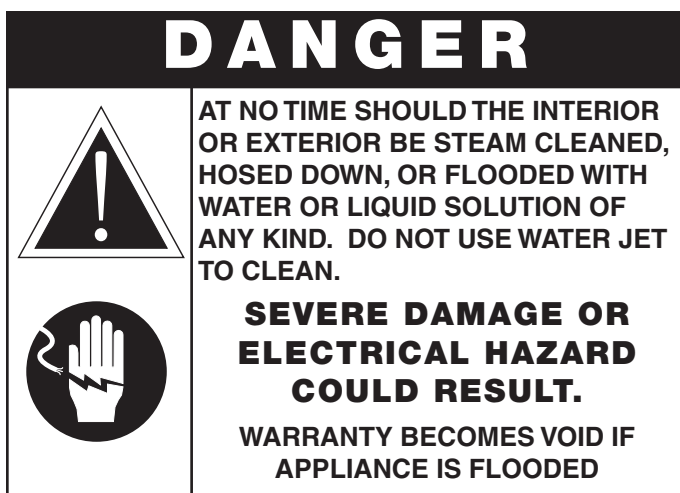

TROUBLESHOOTING

PROBLEM	SOLUTION
Unit does not power on	<ul style="list-style-type: none">• Ensure unit is plugged securely into outlet.• If unit still does not power on, call Service.
Unit heats, but ON/OFF light does not illuminate	<ul style="list-style-type: none">• Call Service.

CAUTION



METAL PARTS OF THIS EQUIPMENT BECOME EXTREMELY HOT WHEN IN OPERATION. TO AVOID BURNS, ALWAYS USE HAND PROTECTION WHEN OPERATING THIS APPLIANCE.

 **DANGER**



DISCONNECT UNIT FROM POWER SOURCE BEFORE CLEANING OR SERVICING.



LOC	PART NO	DESCRIPTION	QTY	UNIT	LOC	PART NO	DESCRIPTION	QTY	UNIT
1	SC-2661	SCREW, 10-32 X1/2, NF PHIL	24	EA	21	5008128	PANEL, LEFT SIDE	1	EA
2	5007076	KETTLE ASSEMBLY ASF-60DS	1	EA	22	5008127	PANEL, RIGHT SIDE	1	EA
	SC-22284	SCREW, M6 X 16 HEX S/S HD (NOT SHOWN)	4	EA	23	CS-28098	CASTER, FRONT LH, SWIVEL	1	EA
3	5007583	CHIMNEY	1	EA	24	CS-28099	CASTER, FRONT RH, SWIVEL	1	EA
4	5007588	CONTROL PANEL	1	EA	25	CS-28101	CASTER, REAR	2	EA
5	5007555	DOOR	1	EA		BT-26884	BRACKET, TETHER (NOT SHOWN)	1	EA
6	PI-27689	PIN, HINGE	2	EA		SC-23670	SCREW, 10-32X1/2,NF PHIL (NOT SHOWN)	4	EA
7	1008494	PANEL, LOWER	1	EA		NU-2215	NUT, 10-32, NF HEX MS (NOT SHOWN)	4	EA
8	BU-3964	STRAIN RELIEF BUSHING	1	EA		SC-24262	1/4-20X5/8" SER FGD HD ZP (NOT SHOWN)	16	EA
9	1008458	PANEL BACK	1	EA	26	HG-27687	HINGE, FRAME LEAF	2	EA
10	MA-25734	DOOR MAGNET	1	EA		SC-2661	SCREW, 10-32X1/2, NF PHIL (NOT SHOWN)	4	EA
11	RI-2097	#42 STAINLESS RIVET	8	EA	27	1008600	PLATE-MAGNET	1	EA
12	1006303	BRACKET, MAGNET	1	EA	28	1009020	PANEL-MANIFOLD ACCESS	2	EA
13	SW-34375	TOGGLE, OSLO #CRTL111A 125V	1	EA	29	GL-27962	GLASS-CERAN HI TRANSFER	1	EA
13	SW-34351	TOGGLE, 230V	1	EA	30	EL-34519	ELEMENT-IR HEATER, 230V	1	EA
14	PE-28121	PANEL OVERLAY	1	EA	30	EL-3448	HEATER ELEMENT, 120V	1	EA
15	1008388	PANEL, WARMER CONTROL	1	EA	31	1008484	HOLDER, GLASS & CERAMIC HTR	1	EA
16	1008453	BASE	1	EA	32	5007599	WLDMT-HOOD	1	EA
17	BK-3019	TERMINAL BLOCK	1	EA	33	1008482	BODY, SUPPORT COLUMN	1	EA
	SC-2365	SCREW, 6-32X1-1/4 ROUND (NOT SHOWN)	2	EA	34	1008483	COVER, REAR SUPPORT COLUMN	1	EA
	CD-3232	CORDSET, 14/3 SJTOW, 125V (NOT SHOWN)	1	EA	35	5007598	WLDMT-ELEMENT STOP	1	EA
18	1008352	BRACE, UPPER REAR	1	EA	36	BU-3611	5/8" SNAP BUSHING BLACK	2	EA
19	1008351	BRACE, UPPER FRONT	1	EA	37	SC-2661	SCREW, 10-32 X1/2, NF PHIL	7	EA
	1008363	BRACE, LOWER REAR (NOT SHOWN)	1	EA					
20	1008342	BRACE, LOWER FRONT	1	EA					

Parts 29 - 37

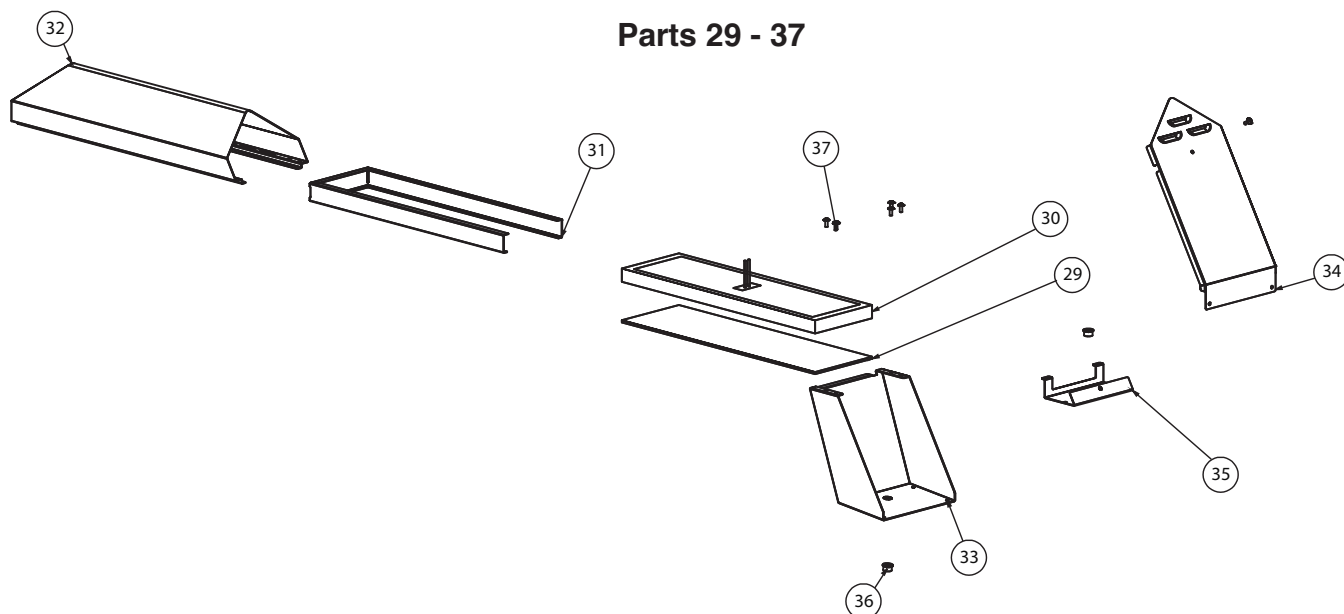

SERVICE

Parts 1 - 28

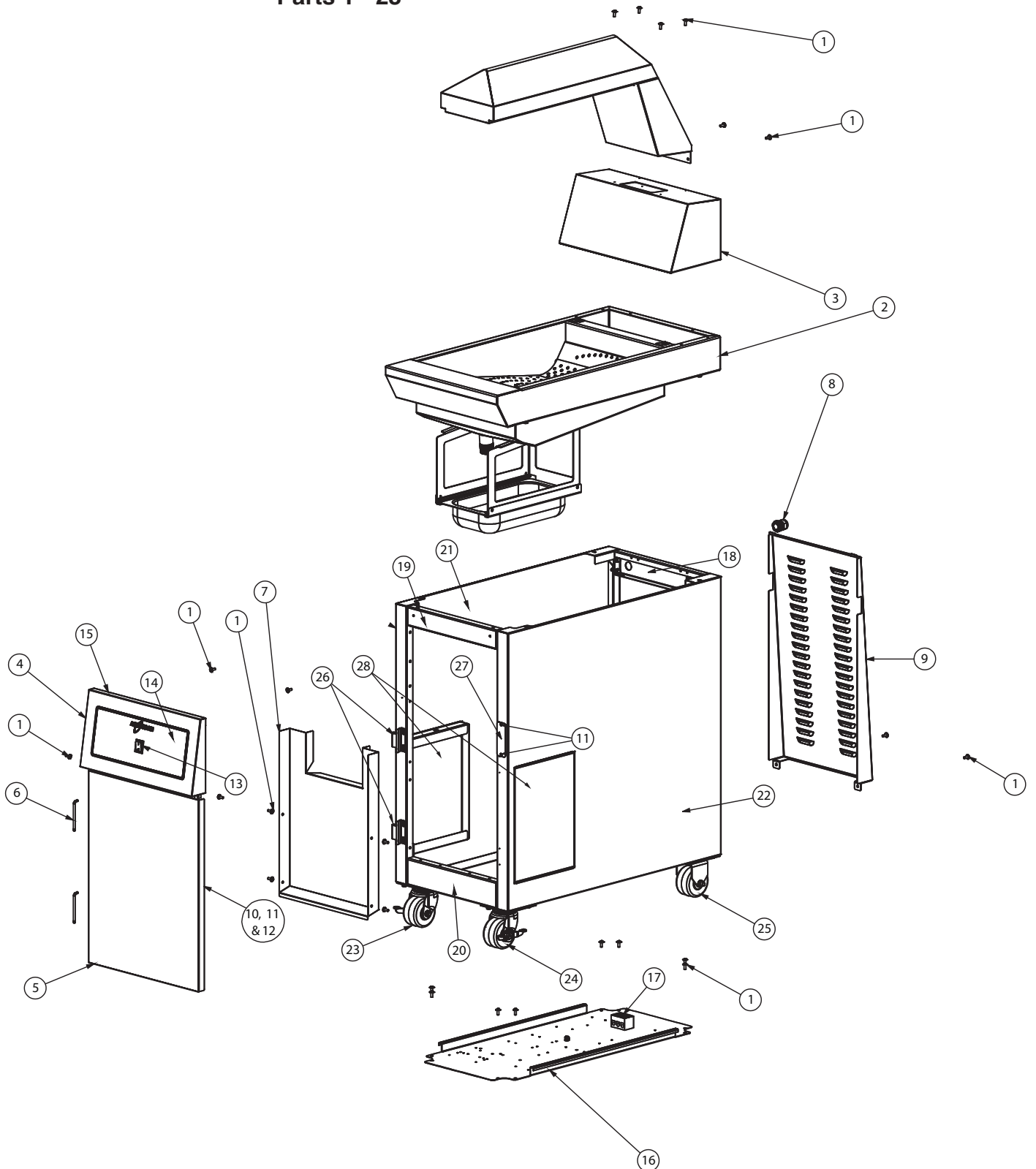

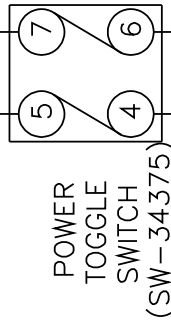
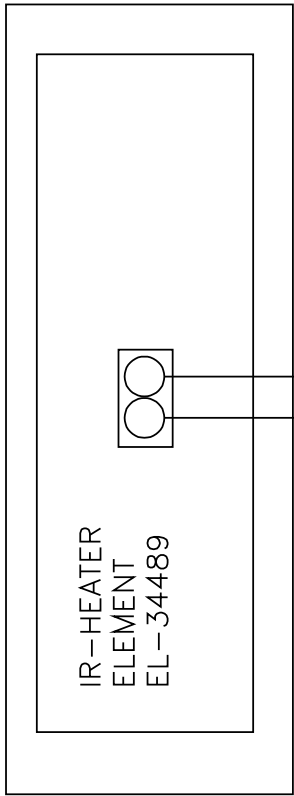

NOTE: USE (2) CONNECTORS (CR-3806)

CD-3232
14/3 SJTOW, 125V

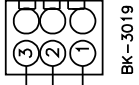
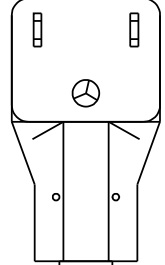

DESIGN	VOLTS	WATTS	AMPS
1	120V	1000W	8.4A
2	120V	X	X

NOTE #1: ALL NUMBERS IN () =
ALTO-SHAAM PART NUMBERS
NOTE #2: SEE DRW. 5007594
FOR WIRE ASSEMBLIES

WIRE DIAGRAM

MODELS: ASF-WS-60E 120V 60HZ
ALTO-SHAAM
 MANUFACTURING & SERVICE
 B.F. MPB SCALE: 1"=1' DRWG: D-77072
 APPD: DATE: 7/27/01

REV A: 04/16/08 MPB
 ADD THE ELECTRICAL RATING BLOCK.

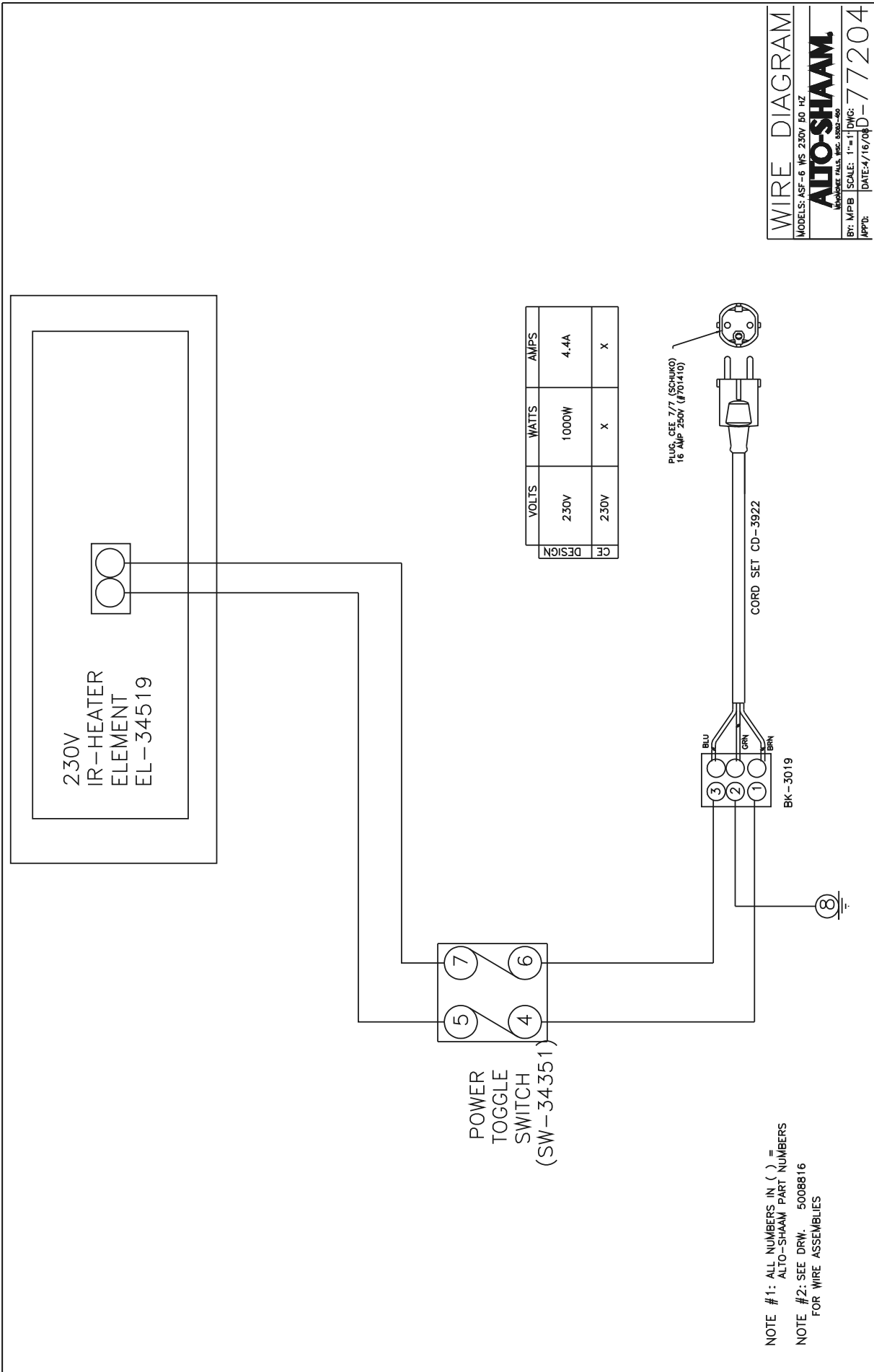

230V
IR-HEATER
ELEMENT
EL-34519

POWER
TOGGLE
SWITCH
(SW-34351)

DESIGN	VOLTS	WATTS	AMPS
CF	230V	1000W	4.4A
	230V	X	X

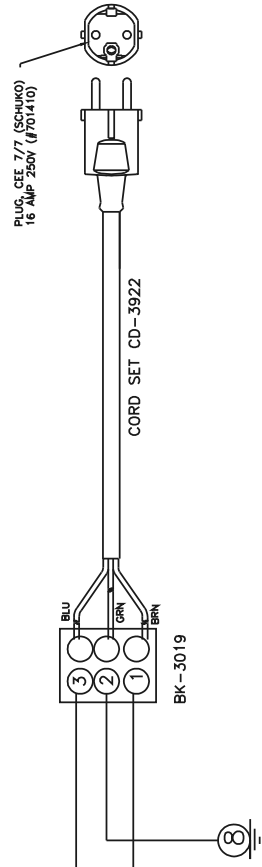

NOTE #1: ALL NUMBERS IN () =
ALTO-SHAAM PART NUMBERS
NOTE #2: SEE DRW. 5008816
FOR WIRE ASSEMBLIES

WIRE DIAGRAM

MODELS: ASF-6 WS 230V 60 HZ
ALTO-SHAAM
 WIRE DIAGRAM, REV. 5/2012-00
 BY: MPB SCALE: 1"=1' DWG:
 APP'D: DATE: 4/16/08 D-77204

TRANSPORTATION DAMAGE and CLAIMS

ALTO SHAAM. LIMITED WARRANTY



All Alto-Shaam equipment is sold F.O.B. shipping point, and when accepted by the carrier, such shipments become the property of the consignee.

Should damage occur in shipment, it is a matter between the carrier and the consignee. In such cases, the carrier is assumed to be responsible for the safe delivery of the merchandise, unless negligence can be established on the part of the shipper.

1. Make an immediate inspection while the equipment is still in the truck or immediately after it is moved to the receiving area. Do not wait until after the material is moved to a storage area.
2. Do not sign a delivery receipt or a freight bill until you have made a proper count and inspection of all merchandise received.
3. Note all damage to packages directly on the carrier's delivery receipt.
4. Make certain the driver signs this receipt. If he refuses to sign, make a notation of this refusal on the receipt.
5. If the driver refuses to allow inspection, write the following on the delivery receipt:
Driver refuses to allow inspection of containers for visible damage.
6. Telephone the carrier's office immediately upon finding damage, and request an inspection. Mail a written confirmation of the time, date, and the person called.
7. Save any packages and packing material for further inspection by the carrier.
8. Promptly file a written claim with the carrier and attach copies of all supporting paperwork.

We will continue our policy of assisting our customers in collecting claims which have been properly filed and actively pursued. We cannot, however, file any damage claims for you, assume the responsibility of any claims, or accept deductions in payment for such claims.

Alto-Shaam, Inc. warrants to the original purchaser that any original part that is found to be defective in material or workmanship will, at Alto-Shaam's option, subject to provisions hereinafter stated, be replaced with a new or rebuilt part.

The labor warranty remains in effect one (1) year from installation or fifteen (15) months from the shipping date, whichever occurs first. Alto-Shaam will bear normal labor charges performed during standard business hours, and excluding overtime, holiday rates or any additional fees.

The parts warranty remains in effect for one (1) year from installation or fifteen (15) months from the shipping date, whichever occurs first.

However, the heating element on Halo Heat® cook/hold ovens and the refrigeration compressor on Alto-Shaam QuickchillersSM are warranted for a period of five (5) years from installation. The labor warranty is the same as stated above; namely, for one (1) year from installation or fifteen (15) months from the shipping date, whichever occurs first.

THIS WARRANTY DOES NOT APPLY TO:

1. Calibration.
2. Replacement of light bulbs and/or the replacement of display case glass due to damage of any kind.
3. Equipment damage caused by accident, shipping, improper installation or alteration.
4. Equipment used under conditions of abuse, misuse, carelessness or abnormal conditions including, but not limited to, equipment subjected to harsh or inappropriate chemicals including, but not limited to, compounds containing chloride or quaternary salts, poor water quality, or equipment with missing or altered serial numbers.
5. Damage incurred as a direct result of poor water quality, inadequate maintenance of steam generators and/or surfaces affected by water quality. Water quality and required maintenance of steam generating equipment is the responsibility of the owner/operator.
6. Damage caused by use of any cleaning agent other than Alto-Shaam's Combitherm® Cleaner including, but not limited to, damage due to chlorine or other harmful chemicals. Use of Alto-Shaam's Combitherm® Cleaner on Combitherm® ovens is highly recommended.
7. Any losses or damage resulting from malfunction, including loss of product or consequential or incidental damages of any kind.
8. Equipment modified in any manner from original model, substitution of parts other than factory authorized parts, removal of any parts including legs, or addition of any parts.

This warranty is exclusive and is in lieu of all other warranties, expressed or implied, including the implied warranties of merchantability and fitness for a particular purpose. In no event shall Alto-Shaam be liable for loss of use, loss of revenue or profit, or loss of product, or for any indirect or consequential damages. No person except an officer of Alto-Shaam, Inc. is authorized to modify this warranty or to incur on behalf of Alto-Shaam any other obligation or liability in connection with Alto-Shaam equipment.

ALTO-SHAAM, INC.

RECORD THE MODEL AND SERIAL NUMBER OF THE APPLIANCE FOR EASY REFERENCE.
ALWAYS REFER TO BOTH MODEL AND SERIAL NUMBER IN ANY CONTACT WITH ALTO-SHAAM REGARDING THIS APPLIANCE.

Model: _____ Date Installed: _____
Voltage: _____ Purchased From: _____
Serial Number: _____

W164 N9221 Water Street • P.O. Box 450 • Menomonee Falls, Wisconsin 53052-0450 • U.S.A.
PHONE: 262.251.3800 • 800.558-8744 USA/CANADA FAX: 262.251.7067 • 800.329.8744 U.S.A. ONLY
WEBSITE: www.alto-shaam.com

PRINTED IN U.S.A.