



ED2SYS-48

ED2-48



ED2SYS-72

ED2-72



ED2SYS-96

ED2-96

Models:

**ED2-48; ED2SYS-48
ED2-48/P; ED2SYS-48/P**

EU2SYS-48; EU2SYS-48/P

**ED2-72; ED2SYS-72
ED2-72/P; ED2SYS-72/P
ED2-72/PL; ED2SYS-72/PL
ED2-72/PR; ED2SYS-72/PR**

**EU2SYS-72; EU2SYS-72/P
EU2SYS-72/PL
EU2SYS-72/PR**

**ED2-96; ED2SYS-96
ED2-96/PL; ED2SYS-96/PL
ED2-96/PR; ED2SYS-96/PR**

**EU2SYS-96; EU2SYS-96/P
EU2SYS-96/PL
EU2SYS-96/PR**

- **INSTALLATION**
- **OPERATION**
- **MAINTENANCE**

W164 N9221 Water Street • P.O. Box 450
Menomonee Falls, Wisconsin 53052-0450 U.S.A.

PHONE: 262.251.3800 • 800.558.8744 U.S.A. / CANADA
FAX: 262.251.7067 • 800.329.8744 U.S.A. ONLY
www.alto-shaam.com



Consult instructions
for operation and use.





TABLE OF CONTENTS

Delivery	1
Unpacking	1
Safety Procedures and Precautions	2

Installation

Installation Requirements	4
Clearance Requirements	4
Leveling	4
Cutting Board Installation	4
Dimension Drawings.	5
Electrical Connection	8
Options & Accessories	10

Operating Instructions

Start-up Operation.	10
Operating Procedures	11
Pan Configurations	12
General Holding Guidelines	13

Care and Cleaning

Cleaning and Preventative Maintenance.	14
Preventative Maintenance Checklist.	15
Equipment Care	17
Food Safety	18

Service

Cable Replacements Kits	19
ED2 Series, Full Assembly, Front View	20
ED2 Series, End Glass & Countertop Panels	22
ED2 Series, Substitute Parts for Self-Serve Units	23
ED2 Series, Base Assembly.	24
ED2 Series, Inner Top Assembly	25
BU2 Cart, Full Assembly.	26
BU2 Short Cart, Full Assembly	27

Wire Diagrams *Always refer to the wire diagram(s) included with the unit for most current version*

Warranty

Transportation Damage and Claims	BACK COVER
Limited Warranty	BACK COVER

Delivery

This Alto-Shaam appliance has been thoroughly tested and inspected to ensure only the highest quality unit is provided. Upon receipt, check for any possible shipping damage and report it at once to the delivering carrier. *See Transportation Damage and Claims section located in this manual.*

This appliance, complete with unattached items and accessories, may be delivered in one or more packages. Ensure all standard items and options have been received with each model as ordered.

Save all the information packed with the appliance. Register online at www.alto-shaam.com to ensure prompt service in the event of a warranty parts and labor claim.

This manual must be read and understood by all people using or installing the equipment model. Contact the Alto-Shaam Tech Team Service Department if you have any questions concerning installation, operation, or maintenance.

1-800-558-8744; servicedept@alto-shaam.com

The serial number is required for all inquiries.

Always include both model and serial number(s) in any correspondence regarding the appliance.

Model: _____

Serial number: _____

Purchased from: _____

Date installed: _____ **Voltage:** _____

Unpacking

- Carefully remove the appliance from the carton or crate.

NOTICE: Do not discard the carton and other packaging material until you have inspected the unit for hidden damage and tested it for proper operation.

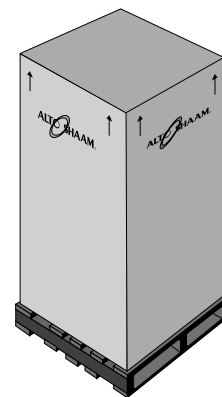

- Read all instructions in this manual carefully before installing this appliance, using the appliance or performing routine maintenance. Following procedures other than those indicated in this guide to use and clean the appliance is considered inappropriate and may cause damage, injury or fatal accidents, in addition to invalidating the guarantee and relieving Alto-Shaam of all liability.
- DO NOT DISCARD THIS MANUAL.** This manual is considered part of the appliance and is provided for the owner or manager of the business and for training personnel. *Additional manuals are available from the Alto-Shaam Tech Team Service Department.*
- Remove all protective plastic film, packaging materials, and accessories from the appliance before connecting electrical power. Store any accessories in a convenient place for future use.



CAUTION



Appliance and accessories may be heavy. To prevent serious injury, **always** use a sufficient number of trained and experienced workers when moving or leveling appliance and handling accessories.

ENVIRONMENTAL CONDITIONS

- Operational Environmental Conditions
- Unit must acclimate to room temperature in the environment it is placed. 24 hours is recommended.
- Ambient temperature range of 60°F to 110°F (16°C to 43°C).
- Relative humidity of less than 95% non-condensation.
- Atmospheric pressure range of 50KPa to 106KPa.

SAFETY PROCEDURES AND PRECAUTIONS

- This appliance is intended to hold foods for the purpose of human consumption. No other use for this appliance is authorized or recommended.
- This appliance is intended for use in commercial establishments where all operators are familiar with the purpose, limitations, and associated hazards of this appliance. Operating instructions and warnings must be read and understood by all operators and users. We recommend regular training of your staff to avoid the risk of accident or damage to the unit. Operators must also receive regular safety instructions.
- Any trouble shooting guides, component views, and parts lists included in this manual are for general reference only and are intended for use by qualified and trained technicians.
- This manual should be considered a permanent part of this appliance. This manual and all supplied instructions, diagrams, schematics, parts lists, notices, and labels must remain with the appliance if the item is sold or moved to another location.

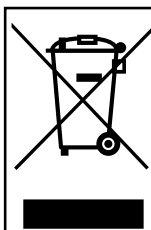

NOTICE: For appliances delivered for use in any location regulated by the following directive (2012/19/EU -WEEE):

Do not dispose of electrical or electronic appliances with other municipal waste.

Knowledge of proper procedures is essential to the safe operation of electrically and/or gas energized equipment. The following hazard signal words and symbols may be used throughout this manual.

DANGER



Used to indicate the presence of a hazard that **WILL** cause severe personal injury, death, or substantial property damage if the warning included with this symbol is ignored.

WARNING



Used to indicate the presence of a hazard that **CAN** cause personal injury, possible death, or major property damage if the warning included with this symbol is ignored.

CAUTION



Used to indicate the presence of a hazard that can or will cause minor or moderate personal injury or property damage if the warning included with this symbol is ignored.

CAUTION

Used to indicate the presence of a hazard that can or will cause minor personal injury, property damage, or a potential unsafe practice if the warning included with this symbol is ignored.

NOTICE: Used to notify personnel of installation, operation, or maintenance information that is important but not hazard related.



Used to indicate that referral to operating instructions is a mandatory action. If not followed the operator could suffer personal injury.



Used to indicate that referral to operating instructions is recommended to understand operation of equipment.

Additional Safety Procedures and Precautions

- To prevent serious injury, death or property damage, your appliance should be inspected and serviced at least every twelve (12) months by an authorized service partner or trained technician.
- ONLY allow an authorized service partner or trained technician to service or to repair your appliance. Installation or repairs that are not performed by an authorized service partner or trained technician, or the use of non-factory authorized parts will void the warranty and relieve Alto-Shaam of all liability.
- When working on this appliance, observe precautions in the literature, on tags, on labels attached to or shipped with the appliance and other safety precautions that may apply.
- If the appliance is installed on casters freedom of movement of the appliance must be restricted so that utility connections (including gas, water, and electricity) cannot be damaged when the unit is moved. If the appliance is moved, make sure that all utility connections are properly disconnected. If the unit is returned to its original position, make sure that any retention devices and utility connections are properly connected.
- ONLY use the appliance when it is stationary. Mobile oven racks, mobile plate racks, transport trolleys, and appliances on casters can tip over when being moved over an uneven floor or threshold and cause serious injury.
- ALWAYS apply caster brakes on mobile appliances or accessories when these are not being moved. These items could move or roll on uneven floors and cause property damage or serious injury.
- Be extremely careful when moving appliances because the food trays may contain hot fluids that may spill, causing serious injury.
- ALWAYS open the appliance door very slowly. Escaping hot vapors or steam can cause serious injury or death.
- If your gas appliance is installed under an exhaust hood, the hood must be switched ON when the oven is in use to avoid the build up of combustion gases. Failure to do so may result in serious injury, death or property damage.
- NEVER place objects near the oven exhaust vents. This area is hot and could be a potential ignition source for a fire.
- Do not allow objects to block or obstruct the area below the oven base. This may result in fire, damage to the equipment or serious injury.
- Do not use the attached hand-held hose to spray anything other than the interior of the oven compartment.
- Do not use the attached hand-held hose on the surface of a hot cooking compartment. The sudden temperature change can damage the oven interior. Allow the oven to cool to a minimum of 150°F (66°C). Failure to observe this precaution can void the warranty.

Additional Safety Procedures and Precautions

CAUTION



Appliance and accessories may be heavy. To prevent serious injury, **always** use a sufficient number of trained and experienced workers when moving or leveling appliance and handling accessories.

WARNING



Hood glass extended to the full, upright portion is stabilized through the use of gas struts designed for the full, load-bearing weight. These struts could weaken or fail due to wear, environmental conditions or aging.

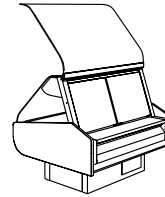

To prevent **SERIOUS INJURY** or **PROPERTY DAMAGE**: Operators should be aware of any increase in effort to lift the hood and initiate an immediate gas strut safety check. **DO NOT** lift the hood in this condition.

INSTALLATION

SITE INSTALLATION

In order to maintain established National Sanitation Foundation standards, all stationary floor models must be sealed to the floor with a R.T.V. or silastic meeting N.S.F. requirements or have 6" (152mm) unobstructed clearance beneath the unit.

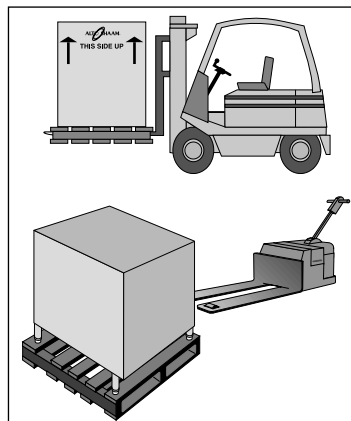

1. The appliance must be installed on a stable and level surface.
2. **DO NOT** install this appliance in any area where it may be affected by any adverse conditions such as steam, grease, dripping water, high temperatures, or any other severely adverse conditions.
3. **DO NOT** install a heated display case near a cold air source such as a freezer, air conditioning vents, or in any area where outside air fluctuation can affect performance.
4. This appliance must be kept free and clear of any obstructions blocking access for maintenance or service.

MINIMUM CLEARANCE REQUIREMENTS

Counter and table units must be mounted on legs of a sufficient 4" (102mm) or 6" (152mm) height depending on unit length to provide minimum unobstructed space beneath the unit. These legs are supplied with the unit. Warranty will become null and void if these directions are not followed.

A number of adjustments are associated with initial installation and start-up. It is important that these adjustments be conducted by a qualified service technician. Installation and start-up adjustments are the responsibility of the dealer or user. These adjustments include but are not limited to thermostat calibration, door adjustment, leveling, electrical hook-up and installation of optional casters or legs.

LEVELING



Level the appliance from side-to-side and front-to-back with the use of a spirit level.

We recommend checking the level periodically to ensure the floor has not shifted nor the appliance moved.

NOTICE: Failure to properly level this appliance can cause improper function.

Cutting board installation:

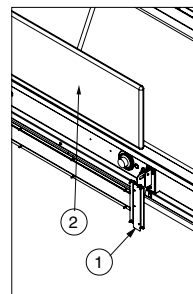

1. Place both brackets in the closed (down) position.
2. Slide cutting board back flanges down onto brackets.
3. Pivot installed board to a horizontal position and slide bracket down to lock in the open position. (NOT SHOWN)

INSTALLATION

SITE INSTALLATION

ED2 & ED2SYS SERIES

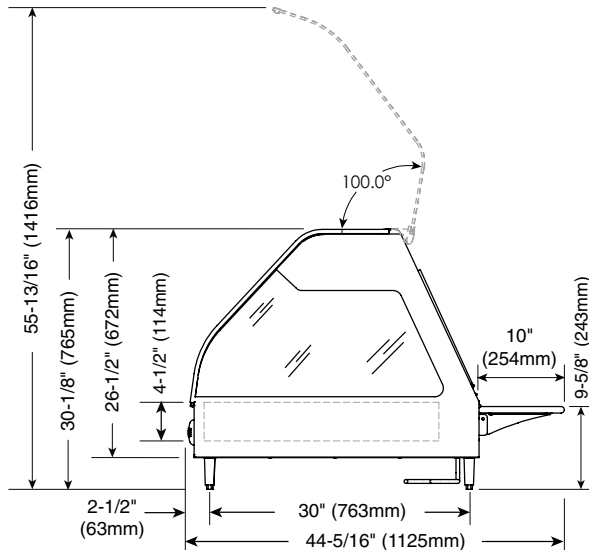
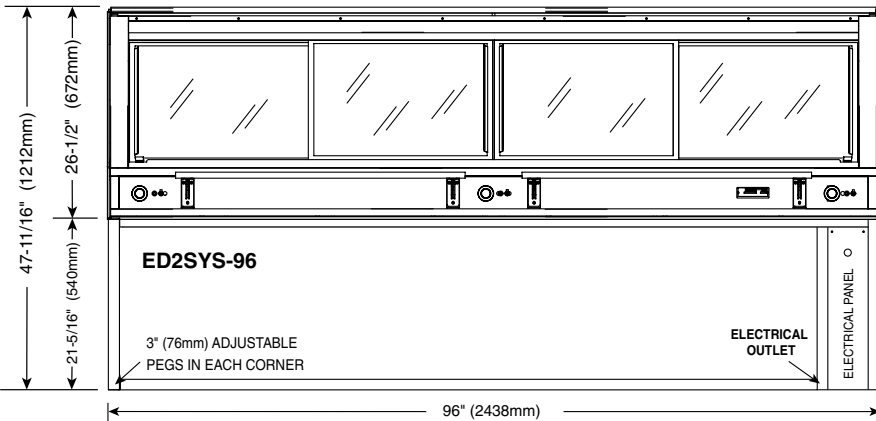
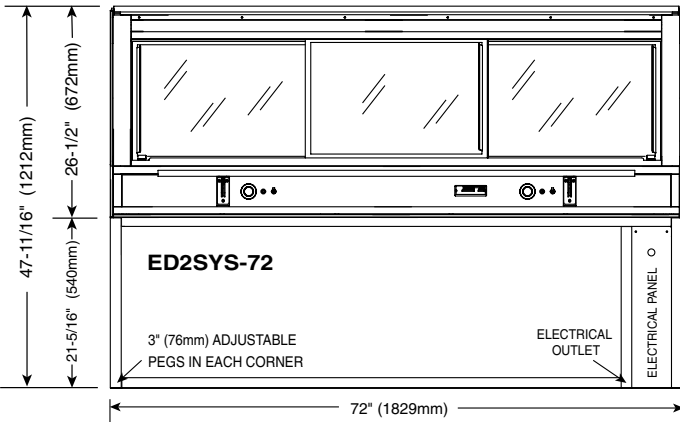
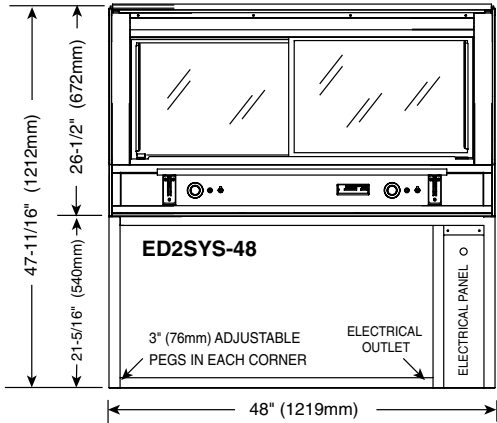

ED2 PROFILE

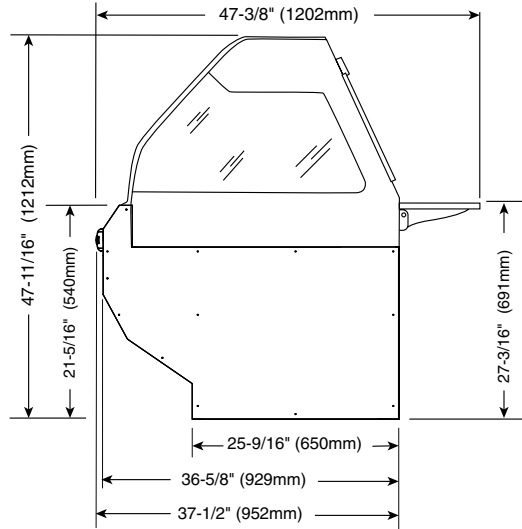

ED2SYS PROFILE

INSTALLATION

SITE INSTALLATION

EU2SYS SERIES

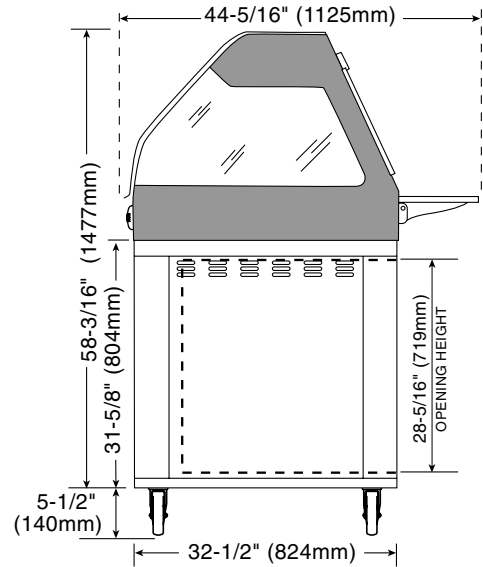
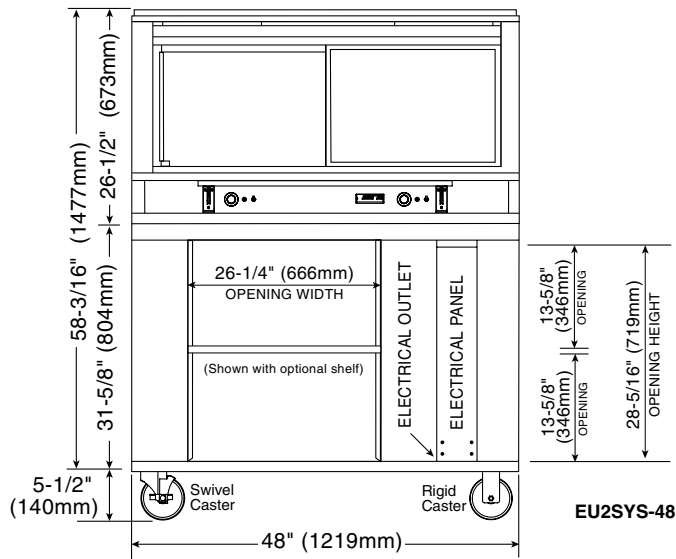

EU2SYS PROFILE

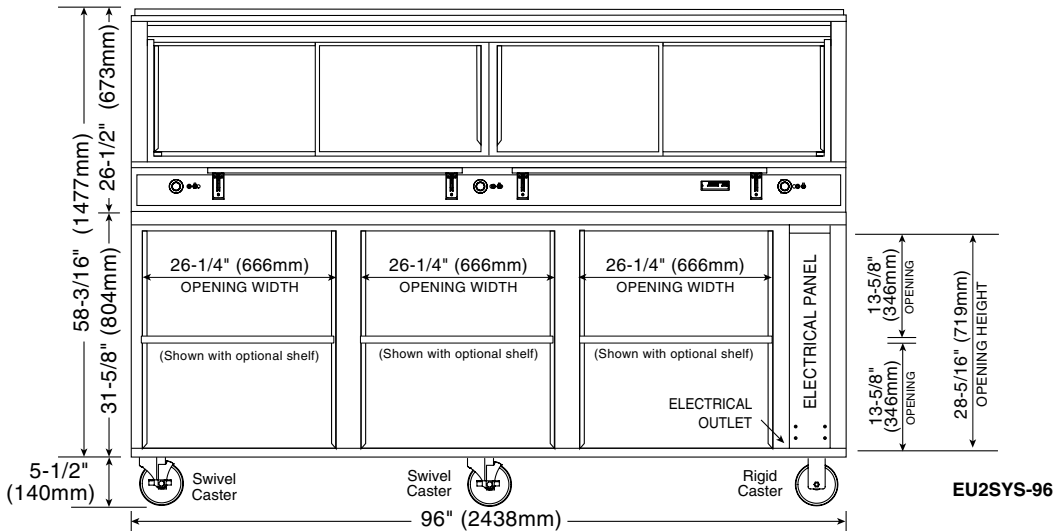
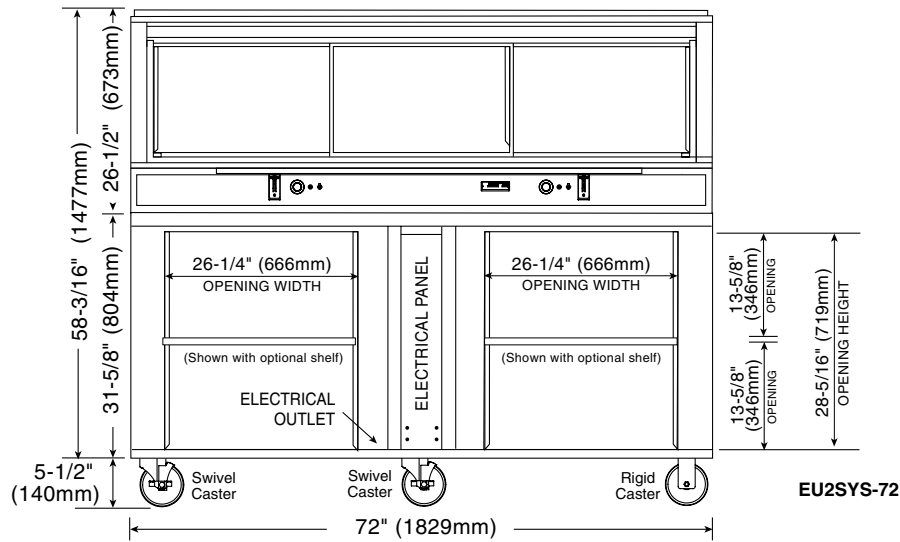

INSTALLATION

SITE INSTALLATION

EU2SYS SHORT SERIES

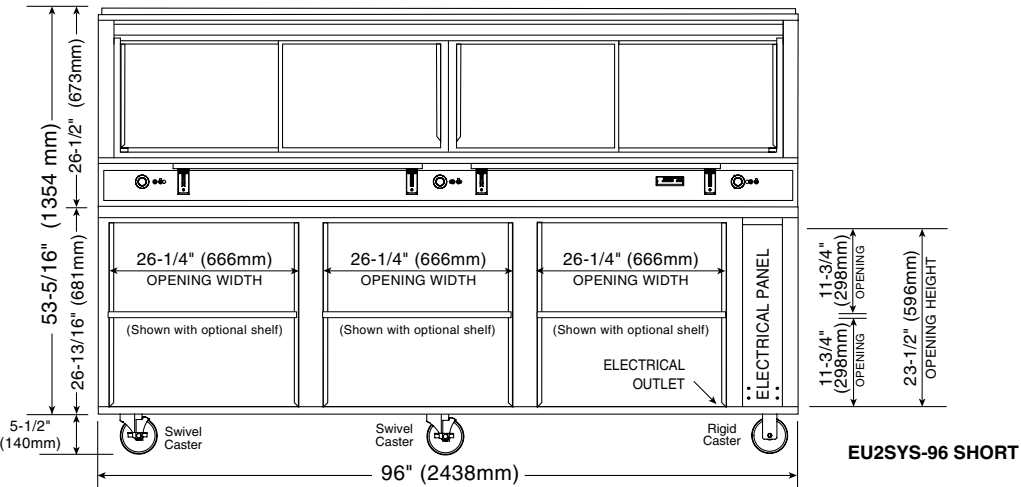
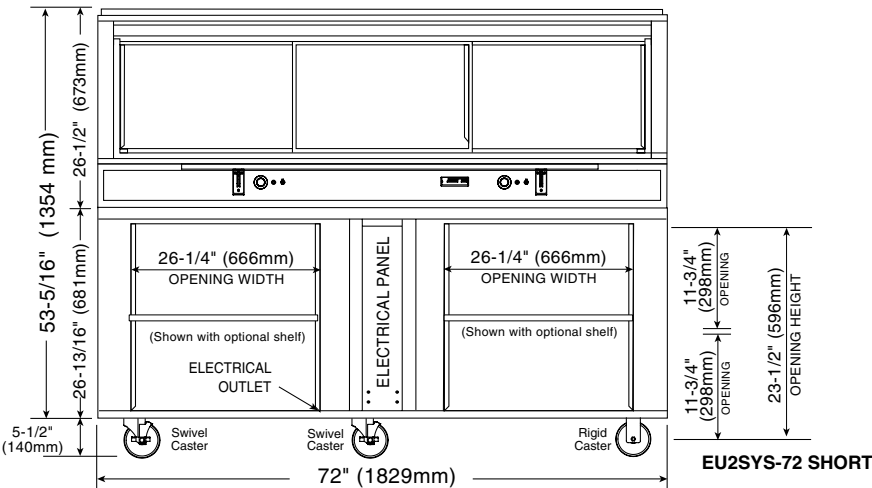
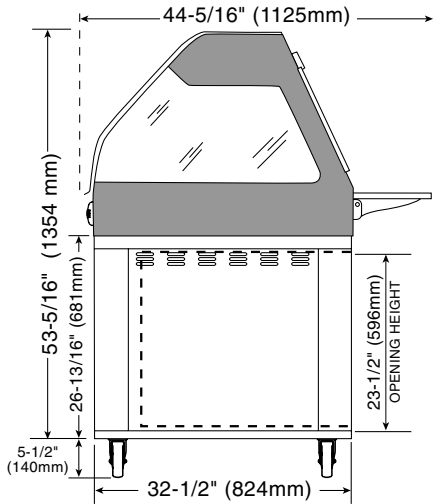
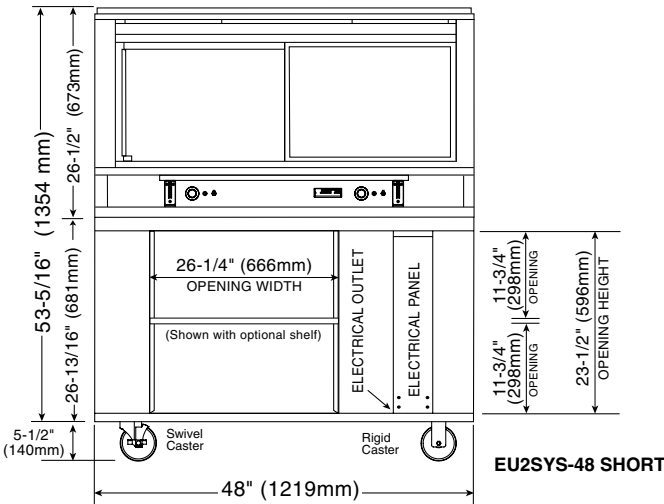

INSTALLATION

ELECTRICAL CONNECTION

CAUTION



Power source must match voltage identified on appliance rating tag. The rating tag provides essential technical information required for any appliance installation, maintenance or repairs. Do not remove, damage or modify the rating tag.

WARNING



To prevent serious injury, death, or property damage:

All electrical connections must be made by a qualified and trained service technician in accordance with applicable electrical codes.



This appliance must be adequately grounded in accordance with local electrical codes or, in the absence of local codes, with the current edition of the National Electrical Code ANSI/NFPA No. 70. In Canada, all electrical connections are to be made in accordance with CSA C22.1, Canadian Electrical Code Part 1 or local codes.



CE-approved appliances include an equipotential-bonding terminal marked with the symbol shown on the left. Provisions for earthing are to be made in accordance with IEC:2010 60335-1 section 27 or local codes.

WARNING



To prevent SERIOUS INJURY, DEATH or PROPERTY DAMAGE:

All electrical connections must be made by a qualified and trained service technician in accordance with applicable electrical codes.

Plug the unit into a properly grounded receptacle **ONLY**, positioning the unit so that the plug is easily accessible in case of an emergency. Arcing will occur when connecting or disconnecting the unit unless all controls are in the "OFF" position.

REGARDING INTERNATIONAL STANDARD UNITS:

If the unit is not equipped with flexible cord and plug, an all-pole country approved disconnection device which has a contact separation of at least 3mm in all poles must be incorporated in the fixed wiring for disconnection. When using a cord without a plug, the green/yellow conductor shall be connected to the terminal which is marked with the ground symbol. If a plug is used, the socket outlet must be easily accessible. If the power cord needs replacement, use a similar one obtained from the distributor.

Hard wired models:





Hard wired models must be equipped with a country certified external allpole disconnection switch with sufficient contact separation.

If a power cord is used for the connection of the product an oil resistant cord like H05RN or H07RN or equivalent must be used.

NOTICE: Where local codes and CE regulatory requirements apply, appliances must be connected to an electrical circuit that is protected by an external GFCI outlet.

ELECTRICAL CONNECTION

Wire diagrams are located in the literature package that came with the unit.

ED2(SYS) SERIES ELECTRICAL					
48 Series					
VOLTAGE	PHASE	CYCLE/HZ	AMPS	kW	
120/208-240	1	50/60	13.8	3.3	NEMA L14-20P 20A, 250V PLUG  (PLUG - COUNTERTOP ONLY; TERMINAL BLOCK - SYSTEM)
208	1	50/60	12.0	2.5	
240	1	50/60	13.8	3.3	
230	1	50/60	12.6	2.9	CEE 7/7 220-230V PLUG  (PLUG - COUNTERTOP ONLY; TERMINAL BLOCK - SYSTEM)
72 Series					
VOLTAGE	PHASE	CYCLE/HZ	AMPS	kW	
120/208-240	1	50/60	18.8	4.5	NEMA L14-30P 30A, 250V PLUG  (PLUG - COUNTERTOP ONLY; TERMINAL BLOCK - SYSTEM)
208	1	50/60	16.3	3.4	
240	1	50/60	18.8	4.5	
230	1	50/60	18.3	4.2	BARE END, NO PLUG (COUNTERTOP ONLY) (TERMINAL BLOCK - SYSTEM)
380-415	3	50/60	9.2	4.4	BARE END, NO PLUG (COUNTERTOP ONLY) (TERMINAL BLOCK - SYSTEM)
380	3	50/60	8.0	3.3	
415	3	50/60	9.2	4.4	
96 Series					
VOLTAGE	PHASE	CYCLE/HZ	AMPS	kW	
120/208-240	1	50/60	21.7	5.2	NEMA L14-30P 30A, 250V PLUG  (PLUG - COUNTERTOP ONLY; TERMINAL BLOCK - SYSTEM)
208	1	50/60	18.8	3.9	
240	1	50/60	21.7	5.2	
230	1	50/60	24.3	5.6	BARE END, NO PLUG (COUNTERTOP ONLY) (TERMINAL BLOCK - SYSTEM)
380-415	3	50/60	12.5	6.0	BARE END, NO PLUG (COUNTERTOP ONLY) (TERMINAL BLOCK - SYSTEM)
380	3	50/60	10.8	4.5	
415	3	50/60	12.5	6.0	

EU2SYS SERIES ELECTRICAL					
48 Series					
VOLTAGE	PHASE	CYCLE/HZ	AMPS	kW	
120/208-240	1	50/60	13.8	3.3	BARE END, NO PLUG
208	1	50/60	12.0	2.5	
240	1	50/60	13.8	3.3	
230	1	50/60	12.6	2.9	
72 Series					
VOLTAGE	PHASE	CYCLE/HZ	AMPS	kW	
120/208-240	1	50/60	18.8	4.5	BARE END, NO PLUG
208	1	50/60	16.3	3.4	
240	1	50/60	18.8	4.5	
230	1	50/60	18.3	4.2	
380-415	3	50/60	9.2	4.4	BARE END, NO PLUG
380	3	50/60	8.0	3.3	
415	3	50/60	9.2	4.4	
96 Series					
VOLTAGE	PHASE	CYCLE/HZ	AMPS	kW	
120/208-240	1	50/60	21.7	5.2	BARE END, NO PLUG
208	1	50/60	18.8	3.9	
240	1	50/60	21.7	5.2	
230	1	50/60	24.3	5.6	
380-415	3	50/60	12.5	6.0	BARE END, NO PLUG
380	3	50/60	10.8	4.5	
415	3	50/60	12.5	6.0	

INSTALLATION

FACTORY INSTALLED OPTIONS

DESCRIPTION	48 SERIES	72 SERIES	96 SERIES
INDEPENDENT ELECTRICAL OUTLET	5001781	5001781	5001781
TEMPERATURE PROBE	5004916	5004917	5004918

ACCESSORIES

DESCRIPTION	48 SERIES	72 SERIES	96 SERIES
BUTTING KIT, COUNTERTOP	5015249	5015249	5015249
BUTTING KIT, SYSTEM	5008523	5008523	5008523
CARVING STATION	5001874	5001874	5001874
CASTERS, PLATE (EU2SYS ONLY)	5" (127mm), RIGID	CS-2025 (2 REQ'D)	CS-2025 (2 REQ'D)
	5" (127mm), SWIVEL WITH BRAKE	CS-2026 (2 REQ'D)	CS-2026 (4 REQ'D)
PAN INSERT, SELF SERVICE	4" (102mm) DEEP	1001990	1001991
PLATFORM SCALE	RIGHT HAND	5001307	5001307
	LEFT HAND	5001308	5001308
SHELF, STAINLESS STEEL (EU2SYS ONLY)		5005786	5005786
SHEET PAN DIVIDER BAR PACKAGE	-48, -48/P	5002802	—
	-72, -72/P	—	5002803
	-72/PL, -72/PR	—	5002804
	2-96	—	—
	2-96/PL, -96/PR	—	—
SHORT BASE (EU2SYS ONLY)	OVERALL HEIGHT REDUCED BY 4-3/4" (121mm)	304332	304342
THERMOSTAT GUARD COVER PLATE		5007660 (2 REQ'D)	5007660 (2 REQ'D)
WORK SHELF WITH GRAVY LANE	2-48, -48/P	5005638	—
	2-72, -72/P, -72/PL, -72/PR	—	5005639
	2-96, -96/P, -96/PL, -96/PR	—	—

OPERATING INSTRUCTIONS

START-UP OPERATION

BEFORE INITIAL USE:

Interior display case surfaces must be heated to remove surface oils and the accompanying odor produced during the first use of the appliance.

Remove pans. Turn thermostats to the "ON" position. Set thermostats to the 10 setting. Allow the unit to heat for 30 minutes or until no odor is detected.

PREHEATING:

The unit should be preheated at the 10 setting for a minimum of 30-45 minutes before loading the case with hot food. Follow the operating instructions indicated on the next page of this manual.

OPERATING INSTRUCTIONS

OPERATING PROCEDURES

1. DO NOT ADD WATER TO DISPLAY CASE

Halo Heat display cases maintain a constant but gentle temperature and eliminate much of the moisture loss associated with conventional display cases. Because of this gentle heat, it is not necessary to add water to the display case. As a matter of fact, **adding water is not recommended** since water will accelerate the deterioration of the product, and will damage the unit voiding the warranty.

2. PLACE DIVIDERS AND SERVING PANS IN CASE

Refer to the pan layout diagrams for different types of pan accommodations. A complete pan configuration layout is located in this manual. **It is VERY important to note**, no matter what type of pan configuration chosen, pan separator bars or divider bars must be used to close all gaps between pans, and all gaps between the pans and the edges of the display case. If these gaps are not closed, heat will escape from the bottom of the case into the display area. As a consequence, heat distribution will be uneven and uniform temperature will be difficult to hold. If needed, additional pan divider bars are available. The supplied self-serve pan inserts with wire grids are for use with pre-packaged foods in the self-serve sections of the units.

3. TURN DISPLAY LIGHTS "ON" AND SET THE THERMOSTAT(S) AT NUMBER "10" TO PREHEAT

A indicator light will illuminate when the thermostat(s) is (are) turned "ON." The indicator(s) will remain lit as long as the unit is preheating or calling for heat. The unit should be preheated at the 10 setting for a minimum of 30-45 minutes before loading the case with hot food. When preheating is completed, or whenever the unit reaches any temperature set by the operator between 1 and 10, the indicator light(s) will go "OUT".

4. LOAD HOT FOODS INTO DISPLAY CASE

Be certain only hot food is transferred into the display case. Before loading food into the case, use a pocket-type meat thermometer to make certain all products have reached an internal temperature of 140° to 160° F (60° to 71°C). If any food product is not at proper serving temperature, use a Halo Heat cooking and holding oven, set at 250° to 275°F (121° to 135°C), or a Combitherm oven to bring the product within the correct temperature range.

- Use hand protection when handling hot items.
- Be certain only hot PREPACKAGED foods in appropriate heat tested containers are used in the self-service section of the display case.
- Do not stack food containers.

5. RESET THERMOSTAT(S) AS NEEDED

After all products are loaded into the display case and the doors are closed, it is necessary to reset the thermostat(s). For fully enclosed sections, reset the thermostat to the number "8" setting. Cases with a self-service section should be maintained between number "9" and number "10" for the self-service section **only**. THESE SETTINGS WILL NOT NECESSARILY BE FINAL. Since proper temperature range depends on the type of products and the quantities being held, it is necessary to periodically use a pocket thermometer to check each item to make certain the correct temperatures are being maintained. Proper temperature range is between a minimum of 140° and 160°F (60° and 71°C). Normally, this will require a thermostat setting of between number "6" and "8" in fully enclosed cases. Self-service cases or sections will always require a higher thermostat setting.

6. PLACEMENT OF FOOD PROBE

If the unit is equipped with the probe accessory, wipe each probe and probe tip with a disposable alcohol pad to clean and sanitize before using. If the probe is left in its bracket, the LED temperature display will indicate the ambient air temperature inside the case. To place a probe into food kept in the case, remove the probe from the bracket and push the probe tip halfway into the product, positioning the tip at the center of the food mass. If placing into solid foods such as meat roast or poultry breasts, push the probe in from a straight downward position or in from the side to the center position. If placing into a semi-liquid or liquid product, the probe cable will probably need to be secured to keep the probe positioned properly. Do not let the probe tip touch the edges or sides. Tape the probe cable to the lip or edge of the container. Wipe each probe tip with a clean paper towel to remove food debris after each use. Follow by wiping probes with a disposable alcohol pad, and return each probe to the proper bracket position.

7. SERVE FRESH HOT FOOD

Keep hot foods looking fresh. Occasionally stir or rotate food as needed. Serve food products in appropriate heat tested packages or containers. Keep display case doors closed after serving. Wipe spills immediately to assure maximum eye appeal and to ease end of the day cleanup.

OPERATING INSTRUCTIONS

PAN CONFIGURATIONS • HEATED DISPLAY CASES

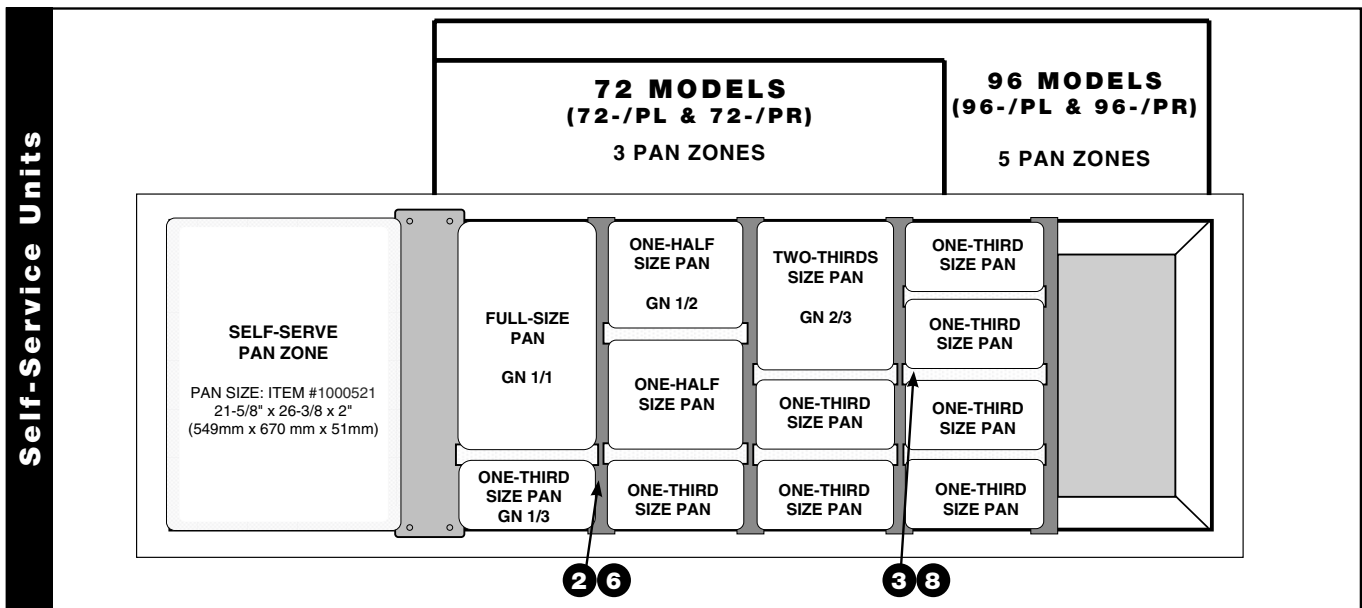
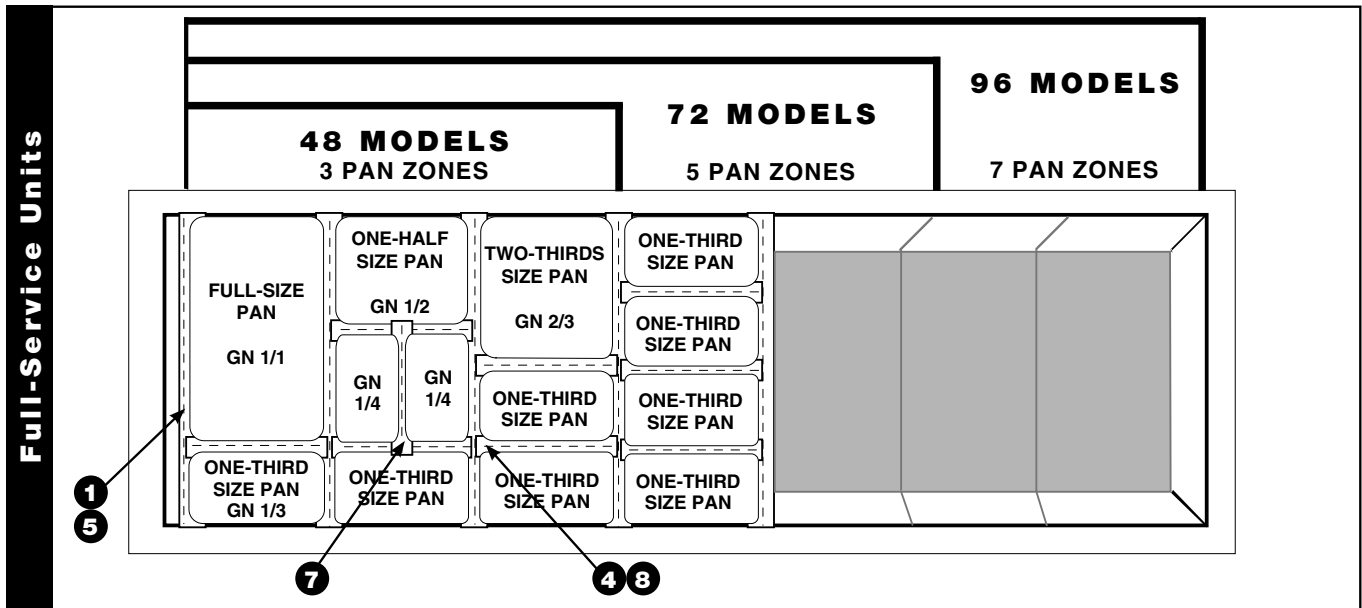

STANDARD BARS INCLUDED IN EACH PACKAGE

PART NO.	DESCRIPTION	DIMENSIONS (W x L)	MODEL >		72		96			
			48	72	FULL	SELF	FULL	SELF		
DOMESTIC PACKAGES										
1	1002584	LONG (FULL, HALF, & THIRD SIZE)	2-1/2" x 28" (64mm x 711mm)		4	—	4	2	—	—
2	1002590	LONG (FULL, HALF, & THIRD SIZE)	1-3/16" x 28" (46mm x 711mm)		—	—	—	—	6	6
3	1002621	SHORT (FULL, HALF, & THIRD SIZE)	1-15/32" x 13-1/2" (37mm x 343mm)		3	—	5	3	7	7
4	11318	SHORT (FULL, HALF, & THIRD SIZE)	1" x 13-1/2" (25mm x 343mm)		9	—	15	9	21	21
INTERNATIONAL PACKAGES										
5	1002585	LONG (GN 1/1, GN 1/2, & GN 1/3)	58mm x 711mm		4	—	10	6	—	—
6	1002591	LONG (GN 1/1, GN 1/2, & GN 1/3)	41mm x 711mm		—	—	—	—	6	6
7	1002619	SHORT (GN 1/4)	25mm x 270mm		6	—	10	6	14	14
8	1000544	SHORT (GN 1/1, GN 1/2, & GN 1/3)	25mm x 327mm		9	—	15	9	21	21

*Not Shown

OPERATING INSTRUCTIONS

GENERAL HOLDING GUIDELINES

Chefs, cooks and other specialized food service personnel employ varied methods of cooking. Proper holding temperatures for a specific food product must be based on the moisture content of the product, product density, volume, and proper serving temperatures. Safe holding temperatures must also be correlated with palatability in determining the length of holding time for a specific product.

Halo Heat maintains the maximum amount of product moisture content without the addition of water, water vapor, or steam. Maintaining maximum natural product moisture preserves the natural flavor of the product and provides a more genuine taste. In addition to product moisture retention, the gentle properties of Halo Heat maintain a consistent temperature throughout the cabinet without the necessity of a heat distribution fan, thereby preventing further moisture loss due to evaporation or dehydration.

When product is removed from a high temperature cooking environment for immediate transfer into equipment with the lower temperature required for hot food holding, condensation can form on the outside of the product and on the inside of plastic containers used in self-service applications. Allowing the product to release the initial steam and heat produced by high temperature cooking can alleviate this condition. To preserve the safety and quality of freshly cooked foods however, a maximum of 1 to 2 minutes must be the only time period allowed for the initial heat to be released from the product.

The unit is equipped with a thermostat indicating a range of between 1 and 10. Use a metal-stemmed indicating thermometer to measure the internal temperature of the product(s) being held. Adjust the thermostat setting to achieve the best overall setting based on internal product temperature.

Holding Temperature Range		
Meat	Fahrenheit	Celsius
Beef Roast — Rare	130°F	54°C
Beef Roast — Med/Well Done	155°F	68°C
Beef Brisket	160°F-175°F	71°C-79°C
Corn Beef	160°F-175°F	71°C-79°C
Pastrami	160°F-175°F	71°C-79°C
Prime Rib — Rare	130°F	54°C
Steaks — Broiled/Fried	140°F-160°F	60°C-71°C
Ribs — Beef Or Pork	160°F	71°C
Veal	160°F-175°F	71°C-79°C
Ham	160°F-175°F	71°C-79°C
Pork	160°F-175°F	71°C-79°C
Lamb	160°F-175°F	71°C-79°C
Poultry		
Chicken — Fried/Baked	160°F-175°F	71°C-79°C
Duck	160°F-175°F	71°C-79°C
Turkey	160°F-175°F	71°C-79°C
General	160°F-175°F	71°C-79°C
Fish/Seafood		
Fish — Baked/Fried	160°F-175°F	71°C-79°C
Lobster	160°F-175°F	71°C-79°C
Shrimp — Fried	160°F-175°F	71°C-79°C
Baked Goods		
Breads/Rolls	120°F-140°F	49°C-60°C
Miscellaneous		
Casseroles	160°F-175°F	71°C-79°C
Dough — Proofing	80°F-100°F	27°C-38°C
Eggs — Fried	150°F-160°F	66°C-71°C
Frozen Entrees	160°F-175°F	71°C-79°C
Hors d'oeuvres	160°F-180°F	71°C-82°C
Pasta	160°F-180°F	71°C-82°C
Pizza	160°F-180°F	71°C-82°C
Potatoes	180°F	82°C
Plated Meals	140°F-165°F	60°C-74°C
Sauces	140°F-200°F	60°C-93°C
Soup	140°F-200°F	60°C-93°C
Vegetables	160°F-175°F	71°C-79°C
The holding temperatures listed are suggested guidelines only. All food holding should be based on internal product temperatures. Always follow local health (hygiene) regulations for all internal temperature requirements.		

CARE AND CLEANING

Protecting Stainless Steel Surfaces



It is important to guard against corrosion in the care of stainless steel surfaces. Harsh, corrosive, or inappropriate chemicals can completely destroy the protective surface layer of stainless steel. Abrasive pads, steel wool, or metal implements

will abrade surfaces causing damage to this protective coating and will eventually result in areas of corrosion. Even water, particularly hard water that contains high to moderate concentrations of chloride, will cause oxidation and pitting that result in rust and corrosion. In addition, many acidic foods spilled and left to remain on metal surfaces are contributing factors that will corrode surfaces.

Proper cleaning agents, materials, and methods are vital to maintaining the appearance and life of this appliance. Spilled foods should be removed and the area wiped as soon as possible but at the very least, a minimum of once per day. Always thoroughly rinse surfaces after using a cleaning agent and wipe standing water as quickly as possible after rinsing.

Cleaning Agents

Use non-abrasive cleaning products designed for use on stainless steel surfaces. Cleaning agents must be chloride-free compounds and must not contain quaternary salts. Never use hydrochloric acid (muriatic acid) on stainless steel surfaces. Failure to observe this precaution will void the warranty. Always use the proper cleaning agent at the manufacturer's recommended strength. Contact your local cleaning supplier for product recommendations.

Cleaning Materials

Cleaning can usually be accomplished with the proper cleaning agent and a soft, clean cloth. When more aggressive methods are needed, use a non-abrasive scouring pad on difficult areas and make certain to scrub with the visible grain of surface metal to avoid surface scratches. Never use wire brushes, metal scouring pads, or scrapers to remove food residue. Failure to observe this precaution will void the warranty.

NOTICE



To protect stainless steel surfaces, completely avoid the use of abrasive cleaning compounds, chloride based cleaners, or cleaners containing quaternary salts. **Never** use hydrochloric acid (muriatic acid) on stainless steel. **Never** use wire brushes, metal scouring pads or scrapers.

WARNING



To prevent **SERIOUS PERSONAL INJURY, DEATH, or PROPERTY DAMAGE:**

If the appliance is not cleaned or is not cleaned well enough, deposits of grease and or food residues inside the appliance may catch fire. If fat deposits and/or food waste inside the appliance ignite disconnect the appliance from the main power and use a fire extinguisher (do not use water to extinguish a grease fire!). Failure to clean the appliance properly may cause fire, personal injury, death, invalidates the warranty and relieves Alto-Shaam of all liability.

CARE AND CLEANING

PREVENTATIVE MAINTENANCE CHECKLIST

SERIAL NUMBER IS REQUIRED FOR ALL INQUIRIES

Always include both model and serial numbers in your correspondence regarding the unit.

Company: _____

Model: _____

Serial Number: _____

Purchased From: _____

Date Installed: _____ **Voltage:** _____

Inspection Date: _____

DAILY CHECK LIST:

- Clean the display case and glass as detailed in this manual.

WEEKLY CHECK LIST:

- Tighten and inspect light bulbs.

MONTHLY CHECK LIST:

- Inspect end and front glass pieces for any signs of chips and cracks.
 - Schedule service immediately if a crack or chip is noted.
- Test gas struts (full service cases only).
 - Lift the front glass fully.
 - Ensure glass remains suspended without dropping back down.
 - If struts are not holding the glass in an upright position, schedule service as soon as possible.

COMPONENT FAILURE & REPLACEMENT

List details of the failure(s) with the date they occurred. (Leave blank if components are working properly)

Component: _____ **Date (MM/DD/YY):** _____

Component: _____ **Date (MM/DD/YY):** _____

Component: _____ **Date (MM/DD/YY):** _____

Component: _____ **Date (MM/DD/YY):** _____

Component: _____ **Date (MM/DD/YY):** _____

Component: _____ **Date (MM/DD/YY):** _____

Component: _____ **Date (MM/DD/YY):** _____

CARE AND CLEANING

PREVENTATIVE MAINTENANCE CHECKLIST

SERIAL NUMBER IS REQUIRED FOR ALL INQUIRIES

Always include both model and serial numbers in your correspondence regarding the unit.

Company: _____

Model: _____

Serial Number: _____

Purchased From: _____

Date Installed: _____ **Voltage:** _____

Inspection Date: _____

EVERY 12 MONTHS CHECK LIST:

Inspection by a factory authorized technician.

- Open control panel and inspect/tighten all wiring.
- Inspect all electrical components.
- Test elements for electrical short to ground. Replace/repair as needed.
- Remove top cover and inspect light wiring and light receptacles. Repair/replace as needed.
- Visually inspect the well and the well surface for any indications of cracking, deterioration, distortion or misuse.
- Replace end glass gasket.
- Inspect handle gasket. Replace as needed.
- Replace sliding glass door gaskets.
- Inspect glass alignment.
- Inspect glass clamp and glass position in clamp. Tighten/replace as needed.
- Inspect any customer bumper material. Replace as needed.
- Perform thermostat calibration based on factory recommended procedures.

COMPONENT FAILURE & REPLACEMENT

Note any component failure(s) that was discovered during this twelve month inspection.
(Leave blank if components are working properly)

CARE AND CLEANING

⚠ WARNING



To prevent serious personal injury, death, or property damage:

Do not steam clean, hose down or flood the interior or exterior with water or liquid solution of any kind. **Do not** use water jet to clean. Failure to observe this precaution will void the warranty.

⚠ WARNING



To prevent serious injury, death, or property damage, **always** disconnect the appliance from the power source before cleaning or servicing.

WARNING



Hood glass extended to the full, upright portion is stabilized through the use of gas struts designed for the full, load-bearing weight. These struts could weaken or fail due to wear, environmental conditions or aging.

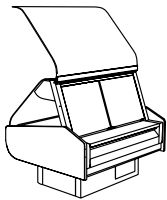

To prevent **SERIOUS INJURY** or **PROPERTY DAMAGE**: Operators should be aware of any increase in effort to lift the hood and initiate an immediate gas strut safety check. **DO NOT** lift the hood in this condition.

DO NOT USE APPLIANCE IF CONTROLS ARE NOT FUNCTIONING PROPERLY

Refer to the Troubleshooting Guide located in this manual or call an authorized service technician.

CLEAN DAILY

- Turn lights and adjustable thermostat(s) to the "OFF" position, disconnect unit from power source and let cool.
- Remove, cover or wrap, and refrigerate food.
- Clean the interior metal surfaces of the display case with a damp clean cloth or sponge and any good commercial detergent or grease solvent at the recommended strength. Use a plastic scouring pad or oven cleaner for difficult areas. Rinse well to remove all residue and wipe dry.

NOTICE: Never use abrasive cleaning compounds, chloride based cleaners, or cleaners containing quaternary salts. Never use hydrochloric acid (muriatic acid) on stainless steel.

- Spray heavily soiled areas with a water soluble degreaser and let stand for 10 minutes, then remove soil with a plastic scouring pad.
- Clean the glass with a window cleaner. The sliding glass doors are removable allowing for easier cleaning.
- Wipe gaskets, control panel and knobs thoroughly since these areas harbor food debris.
- Clean the tracks thoroughly to remove build-up of debris.
- To help maintain the protective film coating on polished stainless steel, clean the exterior of the unit with a cleaner recommended for stainless steel surfaces. Spray the cleaning agent on a clean cloth and wipe with the grain of the stainless steel.

Always follow appropriate state or local health (hygiene) regulations regarding all applicable cleaning and sanitation requirements for equipment.

CLEAN THE PROBES DAILY

If the display case is supplied with probes, remove all food soil from probes. Wipe entire probe and cable assembly with warm detergent solution and a clean cloth. Remove detergent by wiping each probe and cable with clean rinse water and a cloth. Wipe probes with disposable alcohol pad or sanitizing solution recommended for food contact surfaces. Allow probe and cable to air dry in probe holding bracket.



FOOD SAFETY

Food flavor and aroma are usually so closely related that it is difficult, if not impossible, to separate them. There is also an important, inseparable relationship between cleanliness and food flavor. Cleanliness, operating efficiency, and appearance of equipment contribute considerably to savory, appetizing foods.

Most food imparts its own particular aroma and many foods also absorb existing odors. Unfortunately, during this absorption there is not a distinction between **good** and **bad** odors. The majority of objectionable flavors and odors troubling food service operations are caused by bacteria growth. Sourness, rancidity, mustiness, stale or other undesirable flavors are usually the result of germ activity.

The easiest way to ensure full, natural food flavor is through comprehensive cleanliness. This means good control of both visible soil (dirt) and invisible soil (germs). A thorough approach to sanitation will provide essential cleanliness. It will ensure an attractive appearance of equipment, along with maximum efficiency and utility. More importantly, a good sanitation program provides one of the key elements in the prevention of food-borne illnesses.

A comprehensive sanitation program should focus on the training of staff in basic sanitation procedures. This includes personal hygiene, proper handling of raw foods, cooking to a safe internal product temperature, and the routine monitoring of internal food temperatures from the time the food is received through the time the food is served.

A controlled holding environment for prepared foods is just one of the important factors involved in the prevention of food-borne illnesses. Temperature monitoring and control during receiving, storage, preparation, and the service of foods are of equal importance.

The most accurate method of measuring safe temperatures of both hot and cold foods is by internal product temperature. A thermometer is an effective tool for this purpose, and should be routinely used on all products that require holding at a specific temperature.

Internal Food Product Temperatures		
Hot Foods		
Danger Zone	40°F to 140°F	4°C to 60°C
Critical Zone	70°F to 120°F	21°C to 49°C
Safe Zone	140°F to 165°F	60°C to 74°C
Cold Foods		
Danger Zone	Above 40°F	Above 4°C
Safe Zone	36°F to 40°F	2°C to 4°C
Frozen Foods		
Danger Zone	Above 32°F	Above 0°C
Critical Zone	0°F to 32°F	-18°C to 0°C
Safe Zone	0°F or Below	-18°C or Below

Hazard Analysis (at) Critical Control Points (HACCP), is a quality control program of operating procedures to assure food integrity, quality, and safety. Taking steps necessary to augment food safety practices is both cost effective and relatively simple. Additional HACCP information is available by contacting:

Center for Food Safety and Applied Nutrition
Food and Drug Administration
Phone: 1-888-SAFEFOOD
www.foodsafety.gov

CABLE REPLACEMENT KITS

48 SERIES CABLE REPLACEMENT KIT

CABLE HEATING SERVICE KIT NO. 4880

INCLUDES:

CB-3045	CABLE HEATING ELEMENT.....	134 FEET
CR-3226	RING CONNECTOR	4
IN-3488	INSULATION CORNER.....	1 FOOT
BU-3105	SHOULDER BUSHING	4
BU-3106	CUP BUSHING	4
SL-3063	INSULATING SLEEVE	4
TA-3540	HIGH TEMPERATURE TAPE	1 ROLL
ST-2439	STUD, 10/32	4
NU-2215	HEX NUT.....	8

72 SERIES CABLE REPLACEMENT KIT

CABLE HEATING SERVICE KIT NO. 4881

INCLUDES:

CB-3045	CABLE HEATING ELEMENT.....	210 FEET
CR-3226	RING CONNECTOR	12
IN-3488	INSULATION CORNER.....	1 FOOT
BU-3105	SHOULDER BUSHING	12
BU-3106	CUP BUSHING	12
SL-3063	INSULATING SLEEVE	12
TA-3540	HIGH TEMPERATURE TAPE	1 ROLL
ST-2439	STUD, 10/32	12
NU-2215	HEX NUT.....	24

96 SERIES CABLE REPLACEMENT KIT

CABLE HEATING SERVICE KIT NO. 14228

INCLUDES:

CB-3045	CABLE HEATING ELEMENT.....	280 FEET
CR-3226	RING CONNECTOR	8
IN-3488	INSULATION CORNER.....	1 FOOT
BU-3105	SHOULDER BUSHING	8
BU-3106	CUP BUSHING	8
SL-3063	INSULATING SLEEVE	8
TA-3540	HIGH TEMPERATURE TAPE	1 ROLL
ST-2439	STUD, 10/32	8
NU-2215	HEX NUT.....	16

! WARNING



To prevent serious injury, death, or property damage, **always** disconnect the appliance from the power source before cleaning or servicing.

CAUTION



The performance of this unit has been optimized using the factory provided bulbs. These bulbs should be replaced with an exact replacement or with a factory recommended replacement. These bulbs have been treated to resist breakage and must be replaced with similarly treated bulbs in order to maintain compliance with NSF standards. Do not over-tighten bulbs in their receptacles as this may cause damage to the bulb filament.

SERVICE

FULL ASSEMBLY • FRONT VIEW (ED2-96 SHOWN)

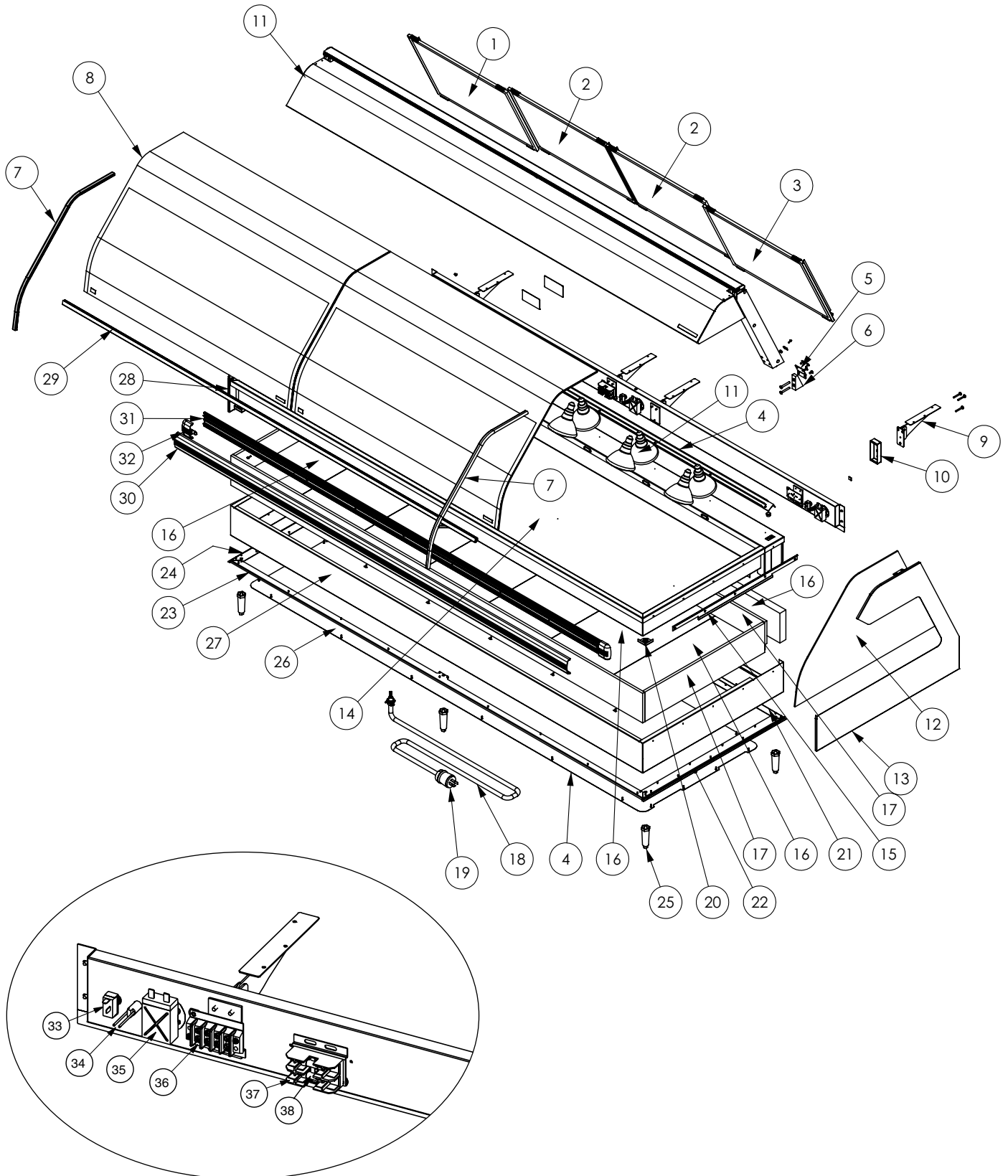

Part numbers and drawings are subject to change without notice.

FULL ASSEMBLY • FRONT VIEW

		MODEL >	ED2(SYS)-48		ED2(SYS)-72		ED2(SYS)-96	
ITEM	DESCRIPTION		PART NO.	QTY	PART NO.	QTY	PART NO.	QTY
1	DOOR GLASS, LH		DR-25422	1	DR-25422	1	DR-25422	1
2	DOOR GLASS, MIDDLE		DR-25423	1	DR-25423	1	DR-25423	2
3	DOOR GLASS, RH		—	—	DR-25424	1	DR-25424	1
4	DOOR TRACK, BOTTOM		TK-26751	1	TK-26753	1	TK-26755	1
5	UPRIGHT ANGLED SUPPORT		1004870	2	1004870	2	1004870	2
6	UPRIGHT WEDGE		BK-26025	2	BK-26025	2	BK-26025	2
7	GASKET, END GLASS		GS-22547	1	GS-22547	1	GS-22547	1
8	FRONT GLASS**		GL-25420	1	GL-25785	1	GL-25420	2
9	BRACKET, CUTTING BOARD		BT-2342	2	BT-2342	2	BT-2342	4
	*CUTTING BOARD		4016	1	4017	1	4016	2
10	BRACKET, CUTTING BOARD		11283	2	11283	2	11283	4
11	BULB	120V/208-240V; 90WATT	LP-33592	6	LP-33592	10	LP-33592	14
		120V/208-240V; 65WATT	LP-34762	6	—	—	—	—
		230V; 80WATT	LP-33783	6	LP-33783	10	LP-33783	14
12	END GLASS***	CLEAR	GL-25762	2	GL-25762	2	GL-25762	2
13	END PANEL, RH***	BLACK	OP-26668	1	OP-26668	1	OP-26668	1
14	WELL, CABLE ASSEMBLY		5003844	1	5003845	1	5003846	1
15	FRAME, GLASS, WELL SUPPORT		1000647	2	1000647	2	1000647	2
16	INSULATION		IN-22364	1	IN-22364	1	IN-22364	1
17	INSULATION		IN-2003	1	IN-2003	1	IN-2003	1
18	CORD, 7" (2133mm)	120V/208-240V	CD-3291	1	CD-3557	1	CD-3557	1
		230V	CD-3922	1	CD-33490	1	CD-33489	1
19	PLUG	NEMA L14-20P, 20A, 250V	PG-3337	1	—	1	—	1
		NEMA L14-30P, 30A, 250V	—	—	PG-3267	—	PG-3267	—
20	LEG MOUNT SPOT		5000712	4	5000712	4	5000712	6
21	REAR PANEL TRIM***	BLACK	OP-26660	1	OP-26664	1	OP-26666	1
22	RIGHT PANEL TRIM***	BLACK	OP-26661	1	OP-26661	1	OP-26661	1
23	FRONT PANEL TRIM***	BLACK	OP-26659	1	OP-26663	1	OP-26665	1
24	LEFT PANEL TRIM***	BLACK	OP-26662	1	OP-26662	1	OP-26662	1
25	LEGS, 4" (102mm)	ADJUSTABLE	LG-2044	4	LG-2044	4	LG-2044	6
26	ACCESS PANEL		1000620	1	1001264	1	1001469	1
27	WELL WRAPPER		1000613	1	1001255	1	1001468	1
28	END PANEL, LH***	BLACK	OP-26667	1	OP-26667	1	OP-26667	1
29	HANDLE, GLASS		HD-27795	1	HD-27796	1	HD-27797	1
30	BUMPER, TRACK		1010949	1	1010950	1	1010951	1
31	BUMPER, RAIL		1010952	1	1010953	1	1010954	1
32	BUMPER, END CAP		BM-29064	2	BM-29064	2	BM-29064	2
33	SWITCH, TOGGLE	120V/208-240V	SW-33896	2	SW-33896	2	SW-33896	3
	SWITCH, TOGGLE	230V	SW-3528	2	SW-3528	2	SW-3528	3
	SWITCH, BOOT	230V	SW-3905	2	SW-3905	2	SW-3905	3
34	INDICATOR LIGHT	120V/208-240V	LI-3951	2	LI-3027	2	LI-3027	3
		230V	LI-3951	2	LI-3951	2	LI-3951	3
35	THERMOSTAT		TT-3498	2	TT-3498	2	TT-3498	3
36	TERMINAL BLOCK	120V/208-240V	—	—	BK-3021	1	BK-3021	1
		230V	BK-3021	1	BK-3021	1	BK-3021	1
		380-415V	—	—	BK-3021	1	BK-3021	1
37	FUSE HOLDER		FU-3772	1	FU-3772	1	FU-3772	1
38	FUSE, 15 AMP		FU-3775	2	FU-3775	2	FU-3775	2
39*	THERMOSTAT KNOB		KN-3473	2	KN-3473	2	KN-3473	3
40*	DOOR GLIDES		DR-22480F	1	DR-22480F	1	DR-22480F	1
41*	DOOR BUMPER		DR-22480G	1	DR-22480G	1	DR-22480G	1
42*	TERMINAL BLOCK, MODULAR	120V/208-240V	BK-25432	1	BK-25432	1	BK-25432	1
		230V	—	—	—	—	BK-25432	1
		380-415V	—	—	BK-25432	1	BK-25432	1

* NOT SHOWN ** See substitute parts section for self-service units (pg 23) ***Standard parts listed, see next page for optional parts.

SERVICE

END GLASS (SEE FULL ASSEMBLY ON PREVIOUS PAGES)

MODEL >		ED2(SYS)-48		ED2(SYS)-72		ED2(SYS)-96	
ITEM	DESCRIPTION	PART NO.	QTY	PART NO.	QTY	PART NO.	QTY
12	END GLASS CLEAR	GL-25762	2	GL-25762	2	GL-25762	2
	SOLAR BRONZE, RH	GL-25728	1	GL-25728	1	GL-25728	1
	SOLAR BRONZE, LH	GL-25727	1	GL-25727	1	GL-25727	1

COUNTERTOP PANELS (SEE FULL ASSEMBLY ON PREVIOUS PAGES)

MODEL >		ED2(SYS)-48		ED2(SYS)-72		ED2(SYS)-96	
ITEM	DESCRIPTION	PART NO.	QTY	PART NO.	QTY	PART NO.	QTY
13	GLASS FRAME, RH BLACK	OP-26668	1	OP-26668	1	OP-26668	1
	STAINLESS STEEL	5001266	1	5001266	1	5001266	1
	CUSTOM COLOR	5001484	1	5001484	1	5001484	1
21	REAR TRIM BLACK	OP-26660	1	OP-26664	1	OP-26666	1
	STAINLESS STEEL	1002021	1	1002023	1	1002025	1
	CUSTOM COLOR	1000392	1	1002464	1	1002466	1
22	RIGHT TRIM BLACK	OP-26661	1	OP-26661	1	OP-26661	1
	STAINLESS STEEL	1002018	1	1002018	1	1002018	1
	CUSTOM COLOR	1002309	1	1002309	1	1002309	1
23	FRONT TRIM BLACK	OP-26659	1	OP-26663	1	OP-26665	1
	STAINLESS STEEL	1002020	1	1002022	1	1002024	1
	CUSTOM COLOR	1000391	1	1002463	1	1002465	1
24	LEFT TRIM BLACK	OP-26662	1	OP-26662	1	OP-26662	1
	STAINLESS STEEL	1002019	1	1002019	1	1002019	1
	CUSTOM COLOR	1002310	1	1002310	1	1002310	1
28	GLASS FRAME, LH BLACK	OP-26667	1	OP-26667	1	OP-26667	1
	STAINLESS STEEL	5001265	1	5001265	1	5001265	1
	CUSTOM COLOR	5001483	1	5001483	1	5001483	1

Part numbers and drawings are subject to change without notice.

SUBSTITUTE PARTS FOR SELF-SERVE UNITS

* NOT SHOWN		MODEL >	ED2(SYS)	-48/P	-72/P	-72/PL, /PR	-96/PL, /PR
ITEM	DESCRIPTION		PART NO.	QTY	QTY	QTY	QTY
1	PAN GRIDS		PN-25752	2	3	1	1
2	PAN INSERT		1000993	1	—	—	—
			1000735	—	1	—	—
			1000521	—	—	1	1
3	GLASS FRONT	FULL-SERVE	GL-25420	—	—	1	—
			GL-25785	—	—	—	1
		SELF-SERVE	GL-25586	1	—	—	—
			GL-25889	—	1	—	—
			GL-25430	—	—	1	1
4*	STRUT, GAS	200N	SU-26848	—	1	—	—
		400N	SU-26849	—	—	2	1
		700N	SU-26851	—	—	—	1
5	TEMPERED GLASS DIVIDER		GL-22049	—	—	1	1
6*	DIVIDER GLASS SUPPORT		5002164	—	—	1	—
			5002165	—	—	—	1
7	GUARD, HEAT ASSEMBLY	COUNTER-TOP	5012882	1	—	—	—
			5013180	—	1	—	—
			5013005R	—	—	1	1
		SYSTEM	5013006R	1	—	—	—
			5017369	—	1	—	—
			5013008R	—	—	1	1
8*	GUARD, HEAT (PRIOR TO 01/11)		GD-25577	1	—	—	—
			GD-25899	—	1	—	—
			GD-24852	—	—	1	1
9*	HOLDER, HEAT GUARD (PRIOR TO 01/11)		1000734	1	—	—	—
			1002065	—	1	—	—
			1001455	—	—	1	1

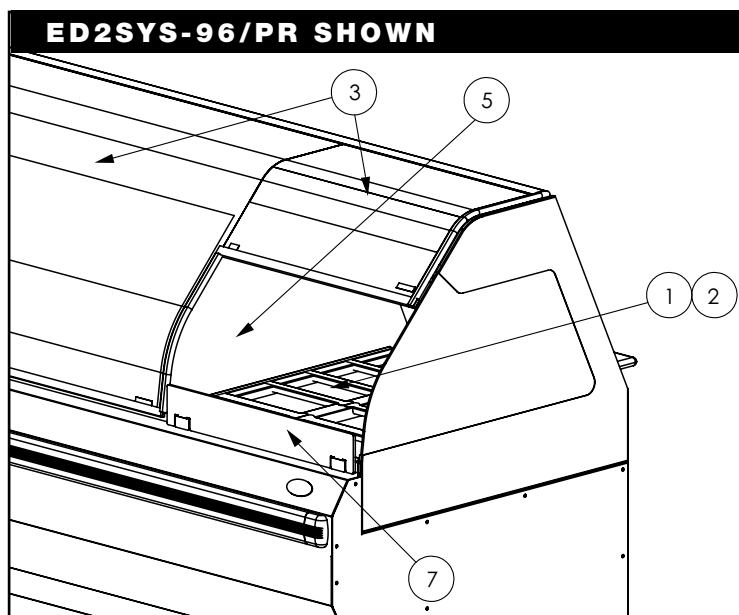

Part numbers and drawings are subject to change without notice.

SERVICE

BASE ASSEMBLY (ED2SYS-96 SHOWN)

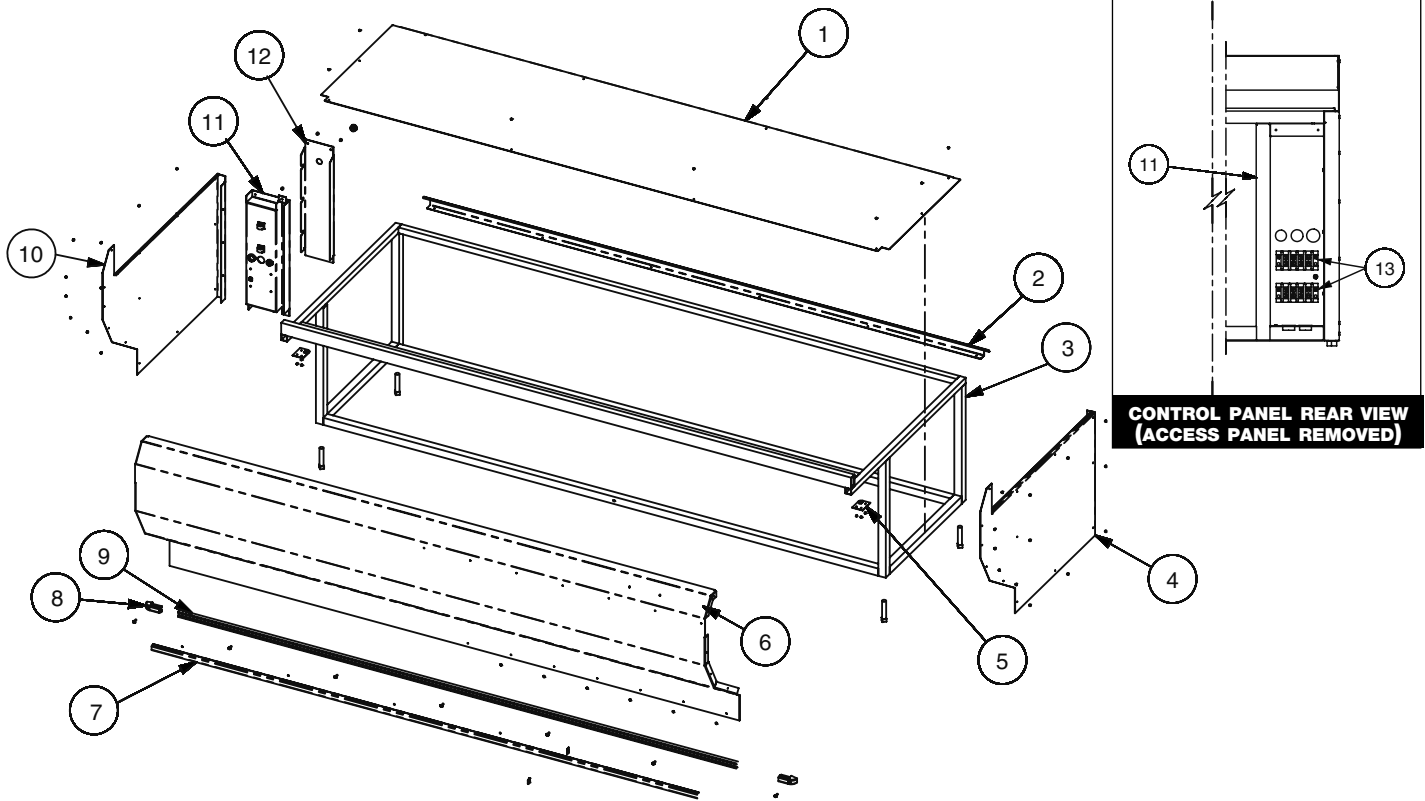

MODEL >		ED2(SYS)-48		ED2(SYS)-72		ED2(SYS)-96	
ITEM	DESCRIPTION	PART NO.	QTY	PART NO.	QTY	PART NO.	QTY
1	PANEL, BASE	1001859	1	1001860	1	1001861	1
2	FILLER, UPPER, REAR	1001862	1	1001863	1	1001864	1
3	FRAME WELD	FR-26725	1	FR-26726	1	FR-26727	1
4	END PANEL, RH	BLACK	1001852	1001852	1	1001852	1
		STAINLESS STEEL	1002055	1002055	1	1002055	1
		CUSTOM COLOR	1002050	1002050	1	1002050	1
5	BRACKET, MOUNTING, LEG	1001915	2	1001915	2	1001915	2
6	FRONT PANEL	BLACK	1001854	1001855	1	1001856	1
		STAINLESS STEEL	1002057	1002056	1	1002059	1
		CUSTOM COLOR	1002052	1002053	1	1002679	1
7	BUMPER, RAIL	4ft (1.22m)	1010952	—	—	—	—
		6ft (1.83m)	—	1010953	1	—	—
		8ft (2.44m)	—	—	—	1010954	1
8	BUMPER, END CAP	BM-29064	2	BM-29064	2	BM-29064	2
9	BUMPER, TRACK	1010949	1	1010950	1	1010951	1
10	END PANEL, LH	BLACK	1001853	1001853	1	1001853	1
		STAINLESS STEEL	1002056	1002056	1	1002056	1
		CUSTOM COLOR	1002051	1002051	1	1002051	1
11	CONTROL PANEL SPOT ASSEMBLY	5001211	1	5001211	1	5001211	1
12	ACCESS PANEL	1001858	1	1001858	1	1001858	1
13	TERMINAL BLOCK	BK-3023	2	BK-3023	2	BK-3023	2

Part numbers and drawings are subject to change without notice.

INNER TOP ASSEMBLY (ED2-96 SHOWN)

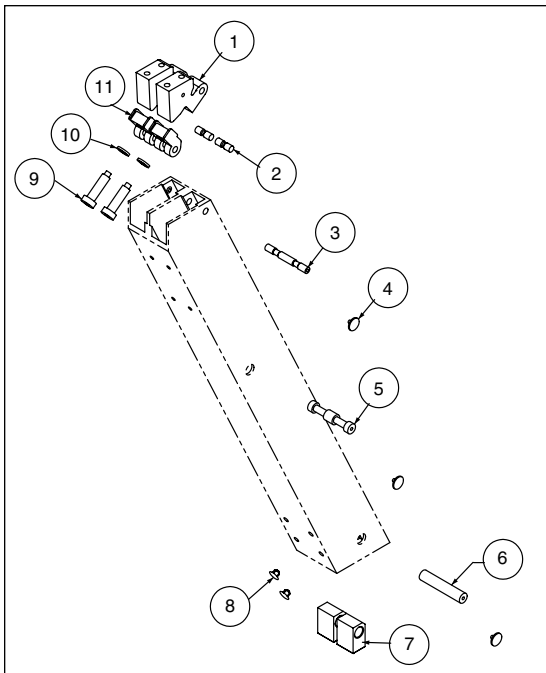
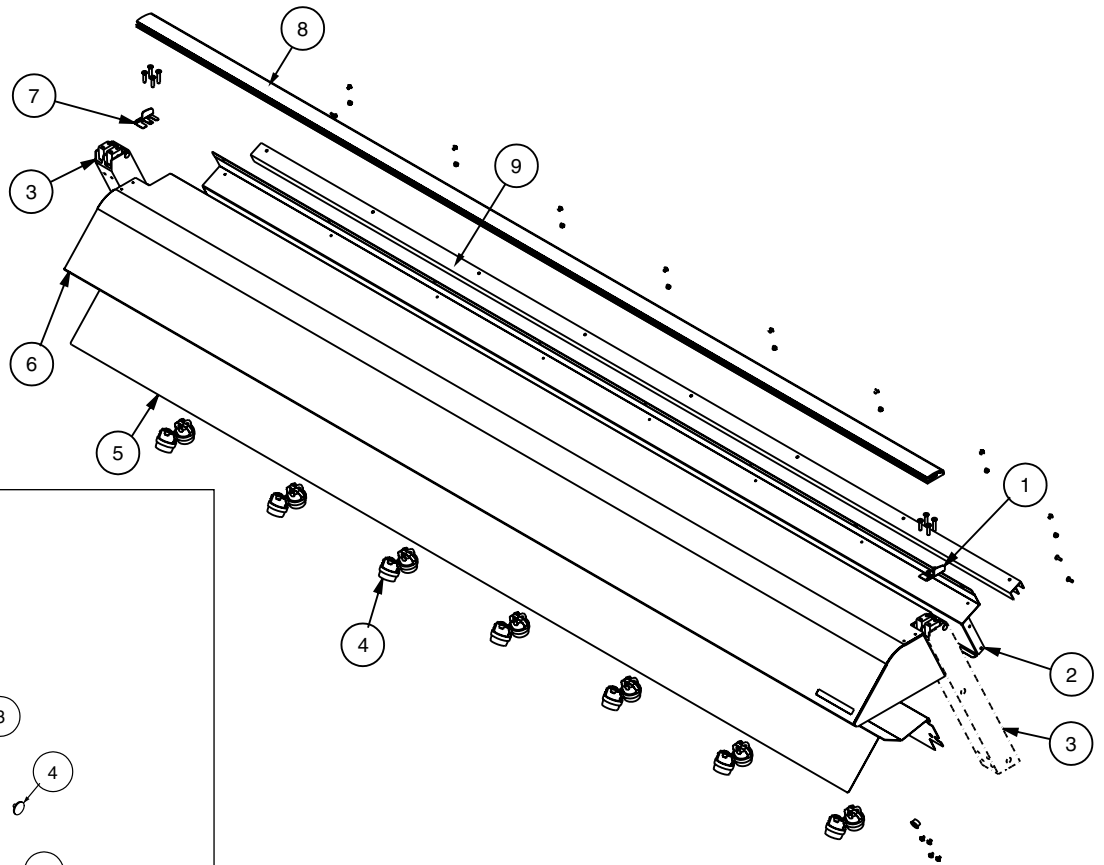

SERVICE HINGE KIT

SERVICE HINGE KIT (HG-28160)

ITEM	DESCRIPTION	QTY	ITEM	DESCRIPTION	QTY
1	25° HINGE	2	7	MOUNTING BLOCKS	2
2	GAS RAM PINS	2	8	HOLE PLUG	2
3	HINGE PIN	1	9	HINGE BOLT	2
4	PIN PLUG	6	10	LOCK WASHERS	2
5	LOWER GAS RAM PIN	1	11	GAS RAM HOLDER	2
6	MOUNTING PIN	1			

* NOT SHOWN		MODEL >	ED2(SYS)-48		ED2(SYS)-72		ED2(SYS)-96	
ITEM	DESCRIPTION		PART NO.	QTY	PART NO.	QTY	PART NO.	QTY
1	CAP, END, RH		CP-27561	1	CP-27561	1	CP-27561	1
2	UPPER DOOR FILLER		1005031	1	1005032	1	1005034	1
3	SERVICE HINGE KIT (SEE INSET)		HG-28160	1	HG-28160	1	HG-28160	1
4	LAMP RECEPTACLE	120V/208-240V	RP-3952	6	RP-3952	10	RP-3952	14
	LAMP RECEPTACLE	230V	RP-3955	6	RP-3955	10	RP-3955	14
5	INNER TOP		1005017	1	1005018	1	1005024	2
6	OUTER TOP		5004030	1	5004031	1	5004034	1
7	CAP, END, LH		CP-27560	1	CP-27560	1	CP-27560	1
8	CLAMP ASSEMBLY		CM-26765	1	CM-26766	1	CM-26767	1
9*	TOP TRACK		TK-26752	1	TK-26754	1	TK-26756	1
10*	STRUT	400N	SU-26849	2	—	—	SU-26849	4
		600N	—	—	SU-26850	2	—	—

Part numbers and drawings are subject to change without notice.

SERVICE

FULL ASSEMBLY (BU2-96 SHOWN)

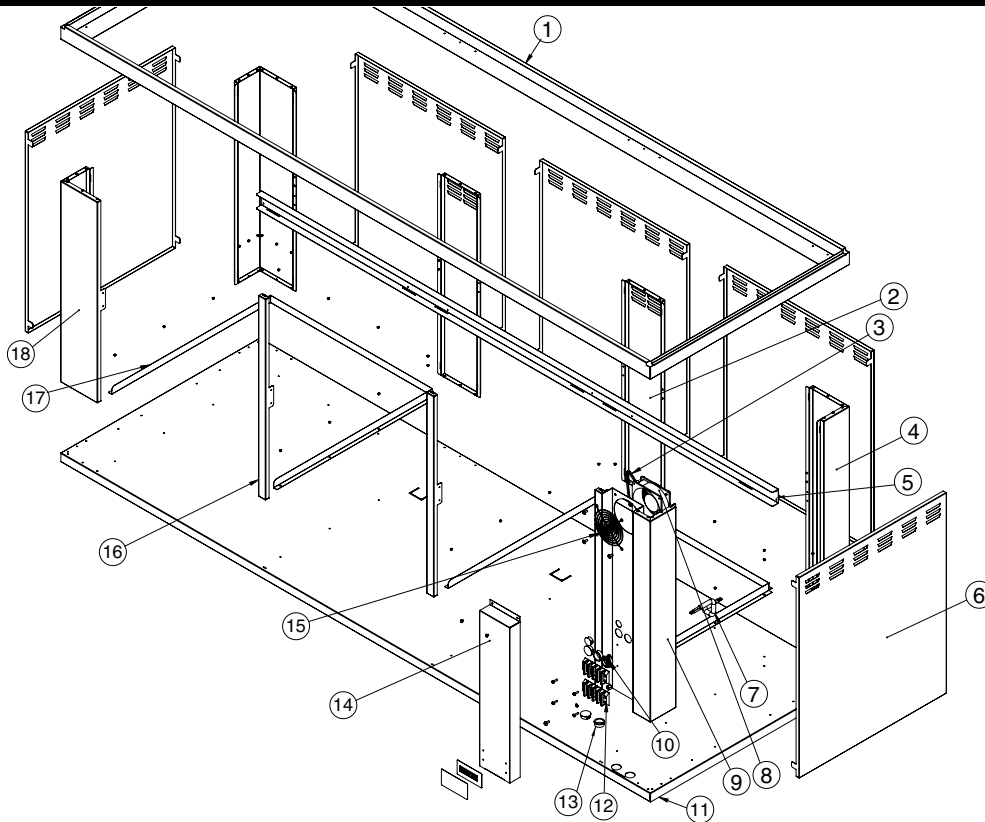

MODEL >		BU2-48		BU2-72		BU2-96	
ITEM	DESCRIPTION	PART NO.	QTY	PART NO.	QTY	PART NO.	QTY
1	TOP FRAME	1006862	1	1006863	1	1006864	1
2	CENTER PANEL	—	—	1006869	1	1006875	2
3	CORD FOR 4" BOX FAN	CD-33338	1	CD-33338	1	CD-33338	1
4	CORNER PANELS	CUSTOMER SIDE 1006794	2	1006794	2	1006794	2
5	REAR SHELF SUPPORT	1007017	1	1007018	1	1007019	1
6	SIDE PANELS	BLACK 1006857	2	1006857	2	1006857	2
		STAINLESS STEEL 1006858	2	1006858	2	1006858	2
		CUSTOM COLOR 1006859	2	1006859	2	1006859	2
	REAR PANELS	BLACK 1006854	1	1006857	2	1006857	3
		STAINLESS STEEL 1006855	1	1006858	2	1006858	3
		CUSTOM COLOR 1006856	1	1006859	2	1006859	3
7	CORD	6ft (1,83m) CD-3607	1	—	—	—	—
		12ft (3,66m) —	—	CD-3607	1	CD-3607	1
8	FAN HOUSING	FA-3568	1	FA-3568	1	FA-3568	1
9	MULLION SPOT	1006795	1	1006870	1	5005506	1
10	3/4" CORD CONNECTOR	CR-3293	1	CR-3293	1	CR-3293	1
11	BASE SPOT	5005544	1	5005545	1	5005546	1
12	TERMINAL BLOCK	BK-3023	2	BK-3023	2	BK-3023	2
13	1-1/8" SNAP BUSHING	BU-3378	2	BU-3378	2	BU-3378	2
14	MULLION COVER	1006796	1	1006796	1	1006796	1
15	FAN GUARD	GD-2396	2	GD-2396	2	GD-2396	2
16	POST CENTER FRONT	—	—	—	—	1006890	2
17	GUIDE RAIL	1006830	1	1006830	2	1006830	2
18	CORNER PANELS OPERATOR SIDE	1006792	1	1006792	1	1006792	1

Part numbers and drawings are subject to change without notice.

FULL ASSEMBLY (BU2-96 SHORT SHOWN)

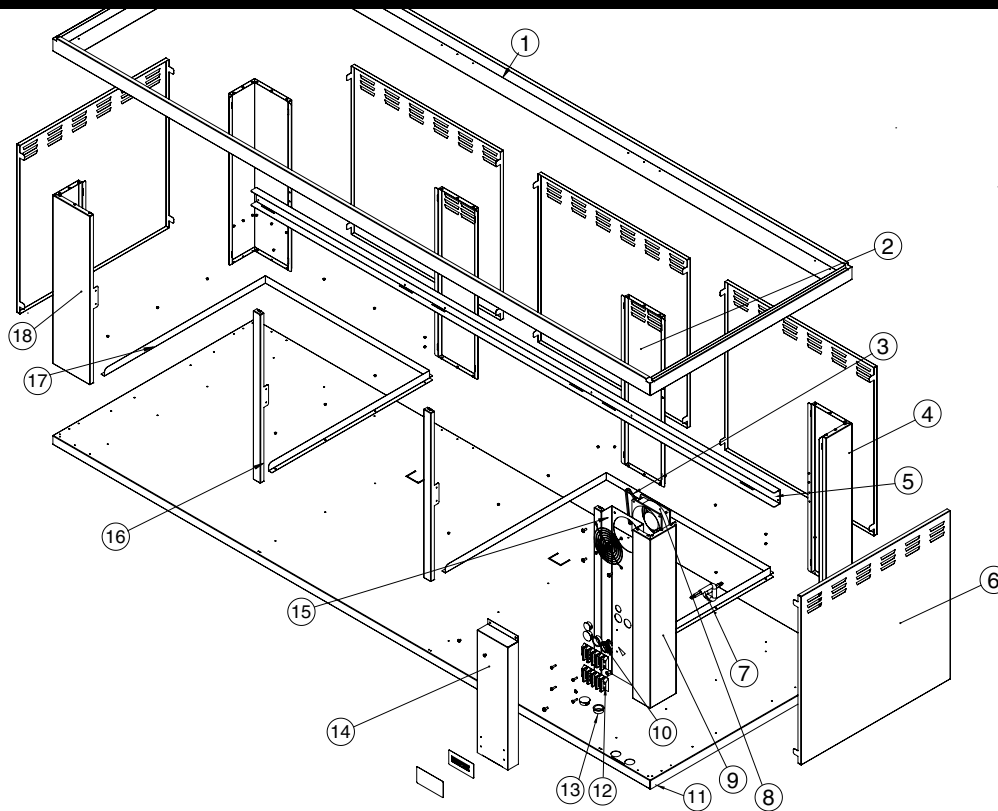

MODEL >		BU2-48 SHORT		BU2-72 SHORT		BU2-96 SHORT	
ITEM	DESCRIPTION	PART NO.	QTY	PART NO.	QTY	PART NO.	QTY
1	TOP FRAME	1006862	1	1006863	1	1006864	1
2	CENTER PANEL	—	—	1006986	1	1006987	2
3	CORD FOR 4" BOX FAN	CD-33338	1	CD-33338	1	CD-33338	1
4	CORNER PANELS	CUSTOMER SIDE	1006988	2	1006988	2	1006988
5	REAR SHELF SUPPORT		1007017	1	1007018	1	1007019
6	SIDE PANELS	BLACK	1006982	2	1006982	2	1006982
		STAINLESS STEEL	1006983	1	1006983	2	1006983
		CUSTOM COLOR	1006984	1	1006984	2	1006984
	REAR PANELS	BLACK	1006979	1	1006982	2	1006982
		STAINLESS STEEL	1006980	1	1006983	2	1006983
		CUSTOM COLOR	1006981	1	1006984	2	1006984
7	CORD	6ft (1,83m)	CD-3607	1	—	—	—
		12ft (3,66m)	—	—	CD-3607	1	CD-3607
8	FAN HOUSING		FA-3568	1	FA-3568	1	FA-3568
9	MULLION SPOT		1006990	1	1006991	1	5005506
10	3/4" CORD CONNECTOR		CR-3293	1	CR-3293	1	CR-3293
11	BASE SPOT		5005544	1	5005545	1	5005546
12	TERMINAL BLOCK		BK-3023	2	BK-3023	2	BK-3023
13	1-1/8" SNAP BUSHING		BU-3378	2	BU-3378	2	BU-3378
14	MULLION COVER		1006978	1	1006978	1	1006796
15	FAN GUARD		GD-2396	2	GD-2396	2	GD-2396
16	POST CENTER FRONT		—	—	—	1006890	2
17	GUIDE RAIL		1006830	1	1006830	2	1006830
18	CORNER PANELS OPERATOR SIDE		1006989	1	1006989	1	1006792

Part numbers and drawings are subject to change without notice.

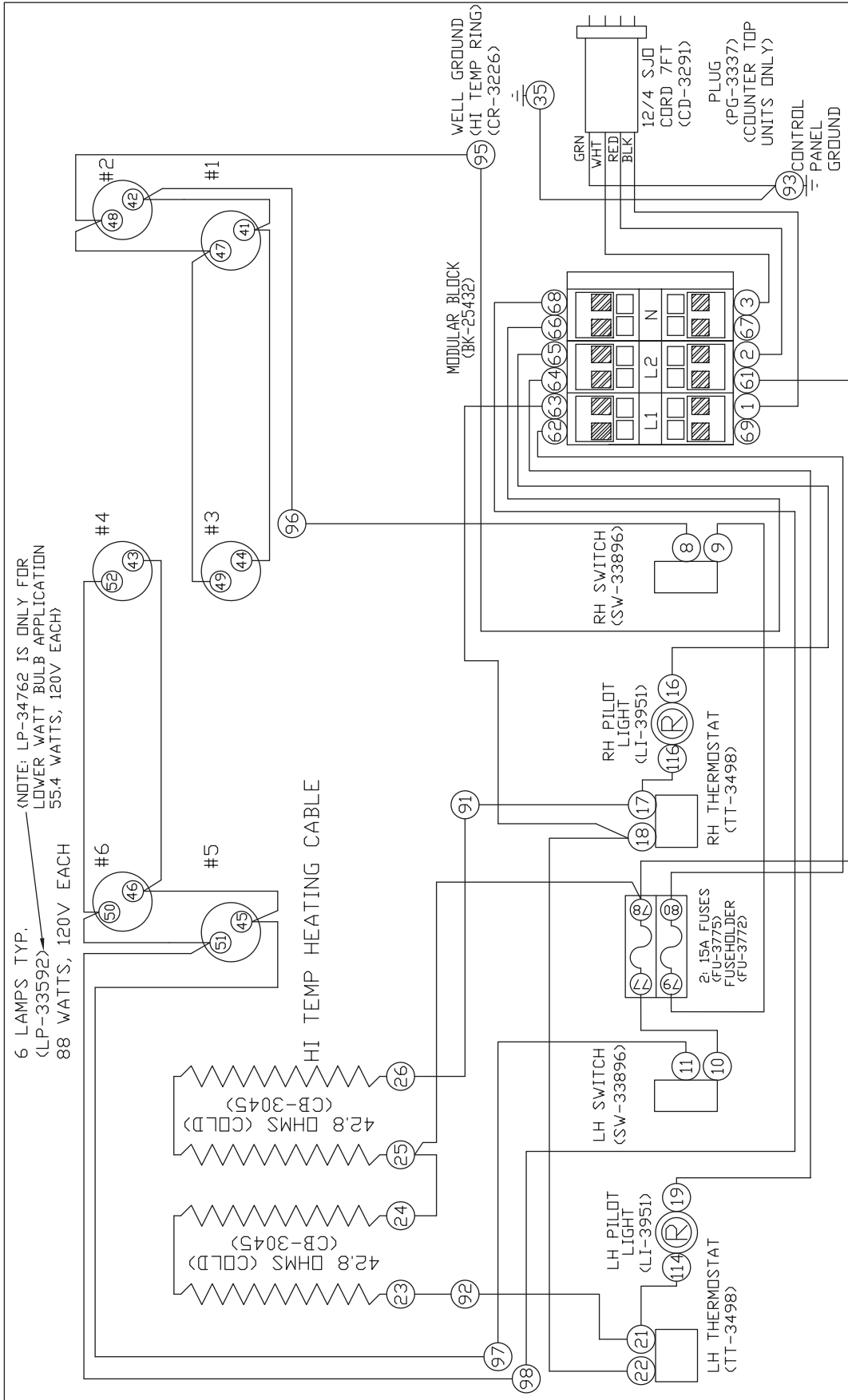

6 LAMPS TYP.
 (LP-33592)
 88 WATTS, 120V EACH
 (NOTE: LP-34762 IS ONLY FOR
 LOWER WATT BULB APPLICATION
 55.4 WATTS, 120V EACH)

HI TEMP HEATING CABLE

REV	ECO	DESCRIPTION	DATE	APP
5	5917	FLIP T-BLOCK WIRING	2/14/11	JPK
4	5396	RELEASED TO PRODUCTION	4/03/09	KDS
3.01	-	BULB CHANGE	3/16/09	JPK
EC2,ED2,HN2,PD2,TY2 (SYS)-48 & /P				

RATINGS WITH 88 WATT BULB		
VOLTS	WATTS	AMPS
208V	2491W	11.6A
240V	3142W	13A
120/208-240V	3320W	13.8A

RATINGS WITH 55.4 WATT BULB		
VOLTS	WATTS	AMPS
208V	2295W	10.2A
240V	2946W	12.3A
120/208-240V	3320W	13.8A

NOTE #1: ALL NUMBERS IN () = ALTO-SHAAM PART NO'S
 NOTE #2: SEE DRW. B-8166 FOR WIRE ASSEMBLIES

ALTO-SHAAM
 WIRING DIAGRAM
 DWG: 7661
 SHEET 1_OF_1
 BY: AHL DATE: 06/11/03

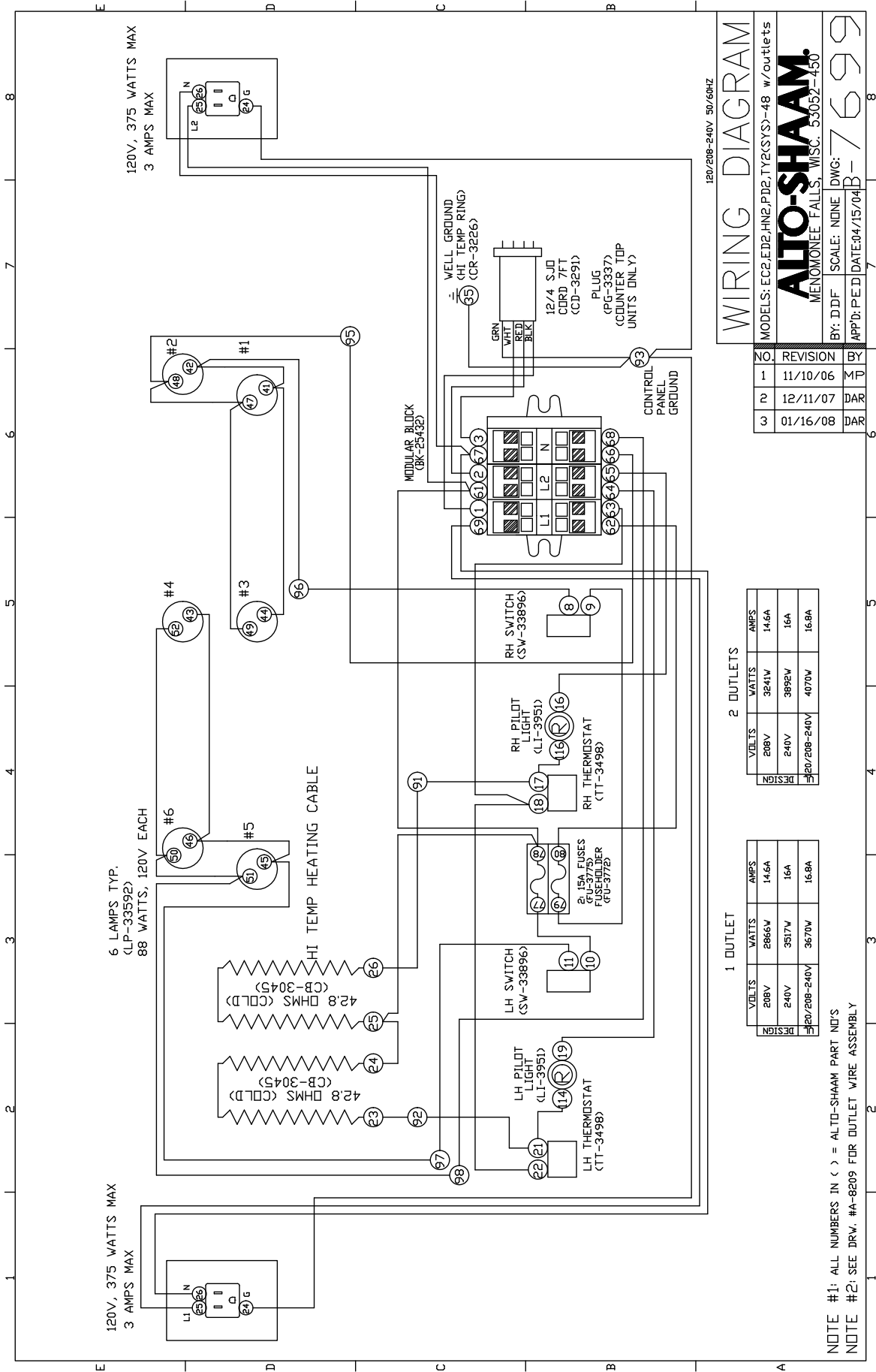

6 LAMPS TYP.
(LP-33783)
77 WATTS, 230V EACH

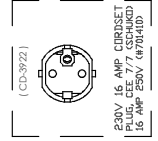
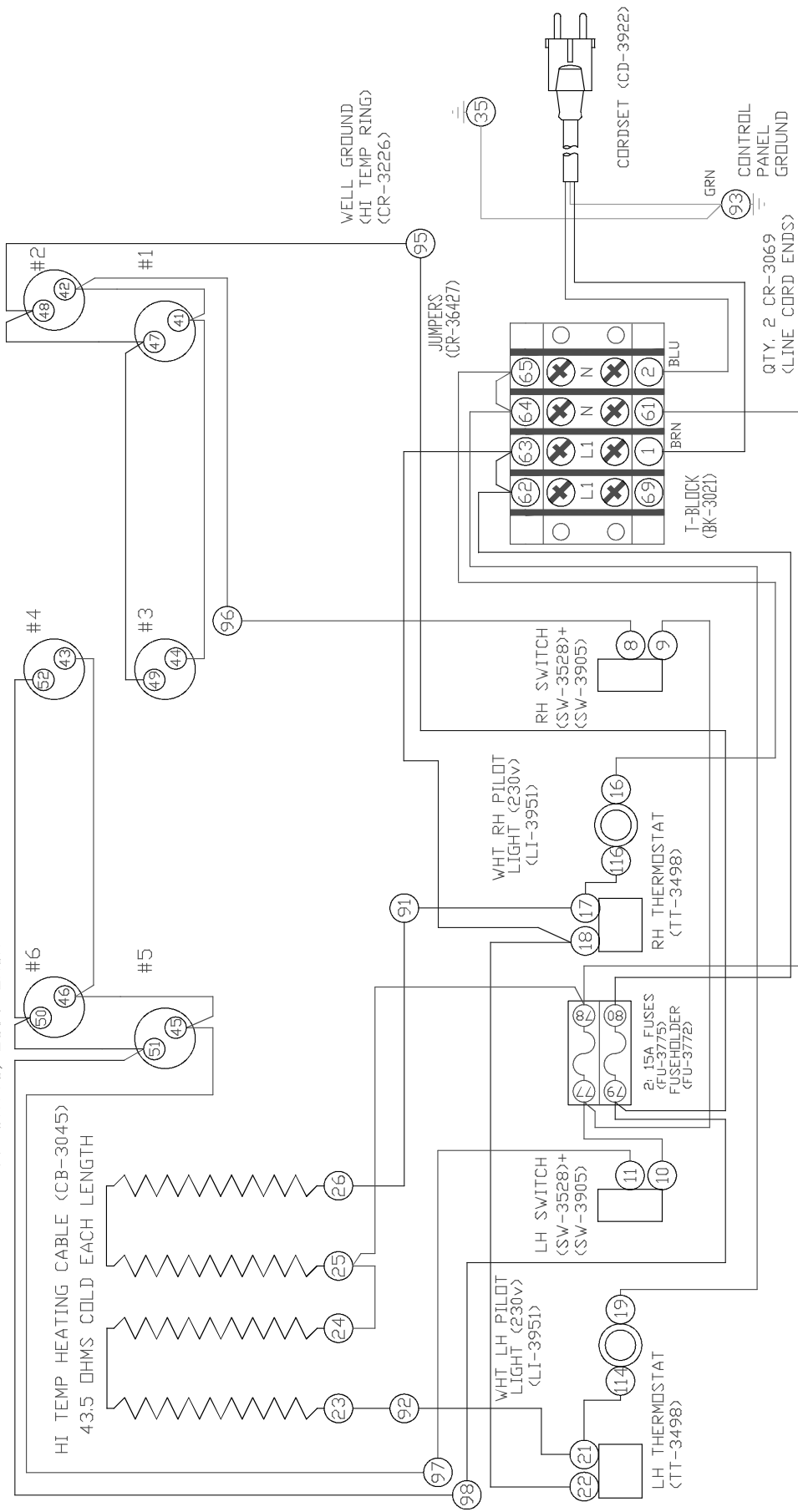

NOTE #1: ALL NUMBERS IN < > = ALTO-SHAAM PART NO'S
NOTE #2: SEE DRW. A-8190 FOR WIRE ASSEMBLIES

7	7178	LP-33783 CHANGED TO 80W	04/24/15	TJG
6	6893	INCLUDE SCHUKO CORDSET	1/23/14	TJG
5	6799	REPLACE TERMINAL BLOCK ADD JUMPERS	10/09/13	TJG
REV	ECO	DESCRIPTION	DATE	APP
EC2,ED2,HN2,PD2,TY2(SYS)-48		/P 230V 50HZ		
ALTO-SHAAM				WIRING DIAGRAM
DWG: 7679			SHEET	1_DF_1
BY: DDF DATE: 1/6/04				

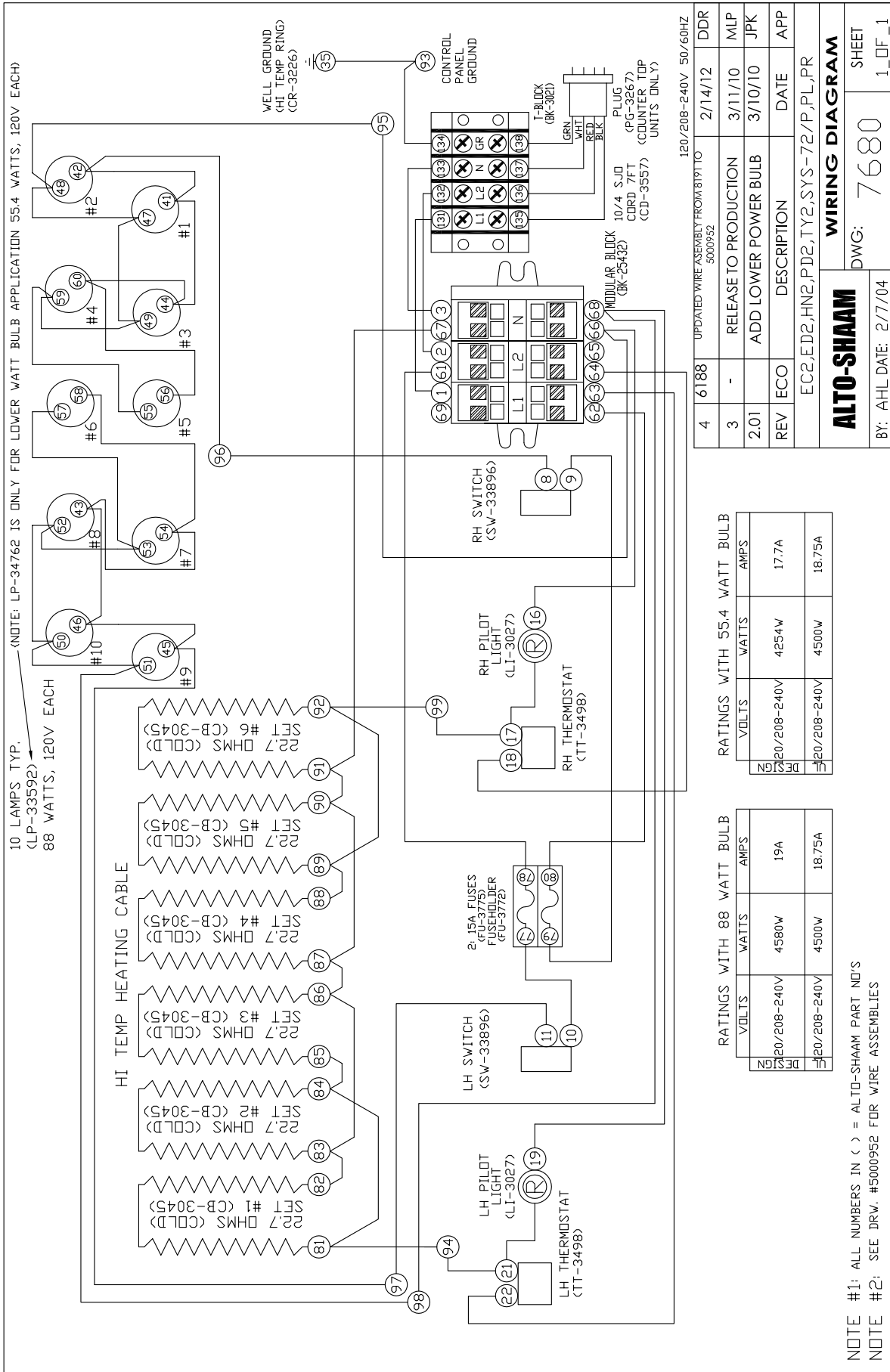

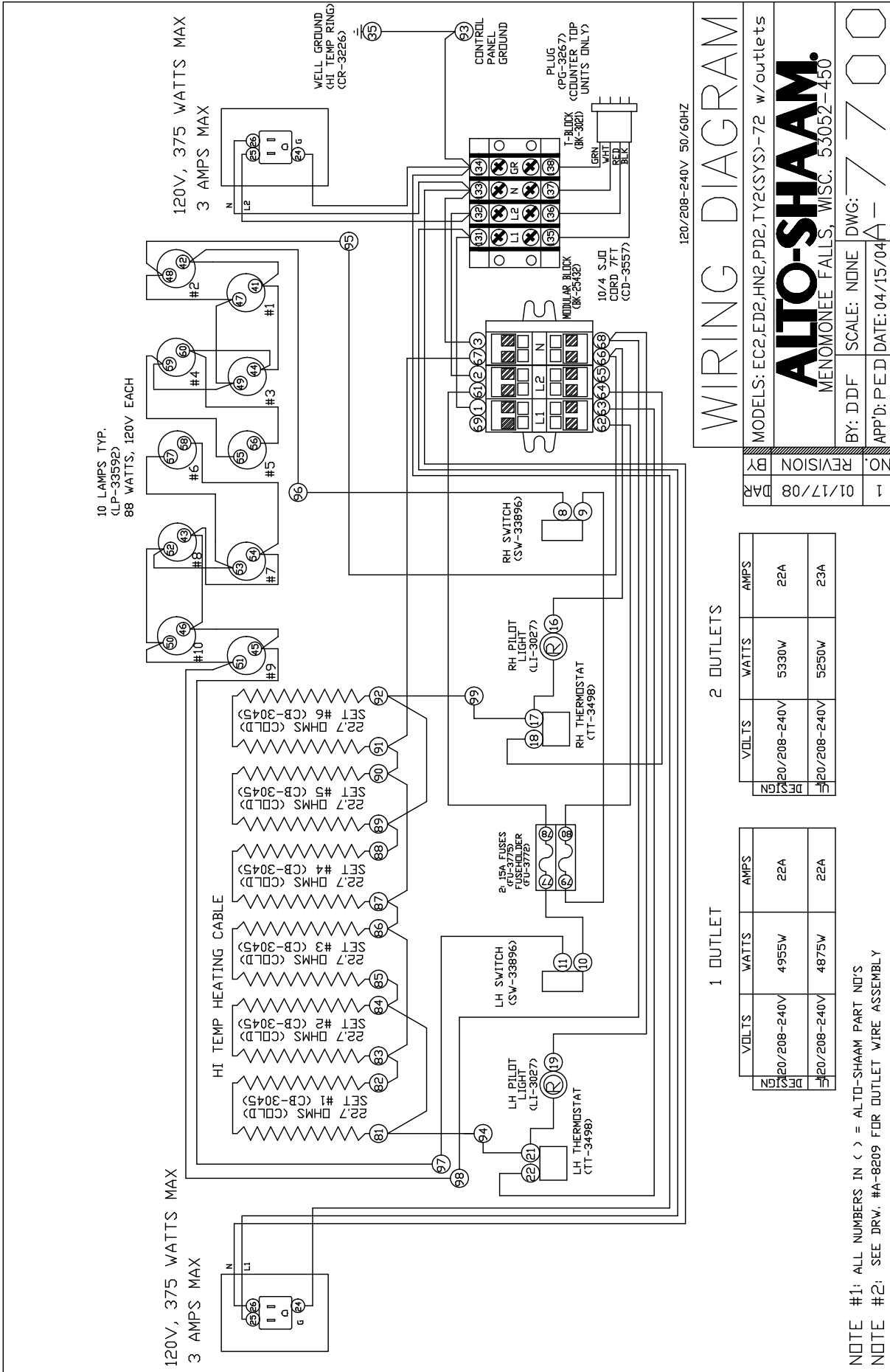

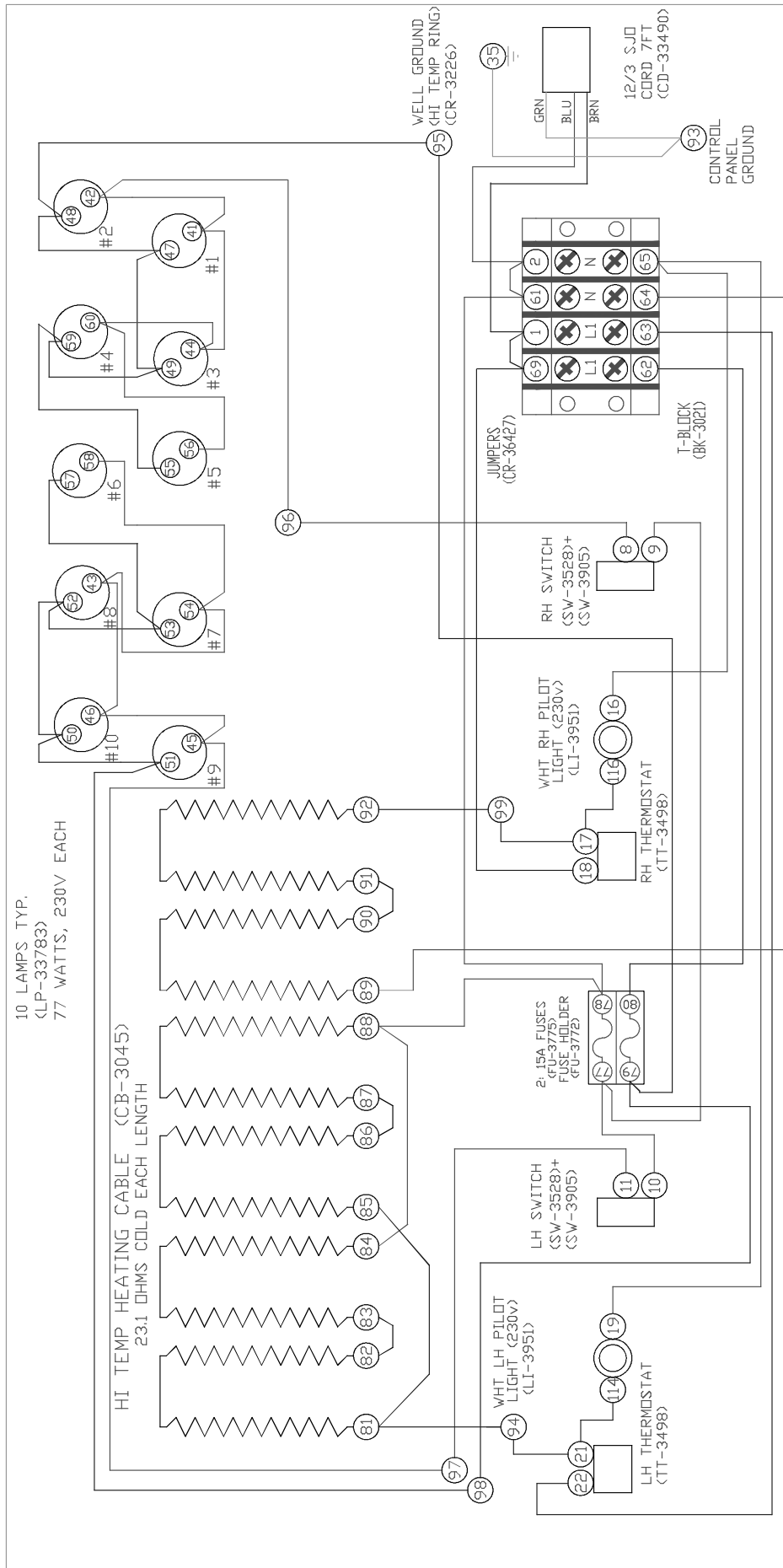

6	7178	IP-33783	CHANGE TO 80W	04/27/15	TJG
5	6799	REPLACE TERMINAL BLOCK ADD JUMPERS		10/14/14	TJG
4	6161	FIX POWER CORD TO BRN AND BLU		02/09/12	DDR
REV	ECO	DESCRIPTION	DATE	APP	
EC2,ED2,HN2,PD2,TY2-(SYS)-72 / P 230V 50HZ					
ALTO-SHAAM				WIRING DIAGRAM	
DWG: 7681				SHEET 1_OF_1	
BY: JPK DATE: 9/30/08					

NOTE #1: ALL NUMBERS IN () = ALTO-SHAAM PART NOS
 NOTE #2: SEE DRW #A-8192 FOR UNIT WIRE ASSEMBLY
 NOTE #3: PR, P SHOWN. FOR PL ADD DASHED WIRE , AND REMOVE WIRE 81-85

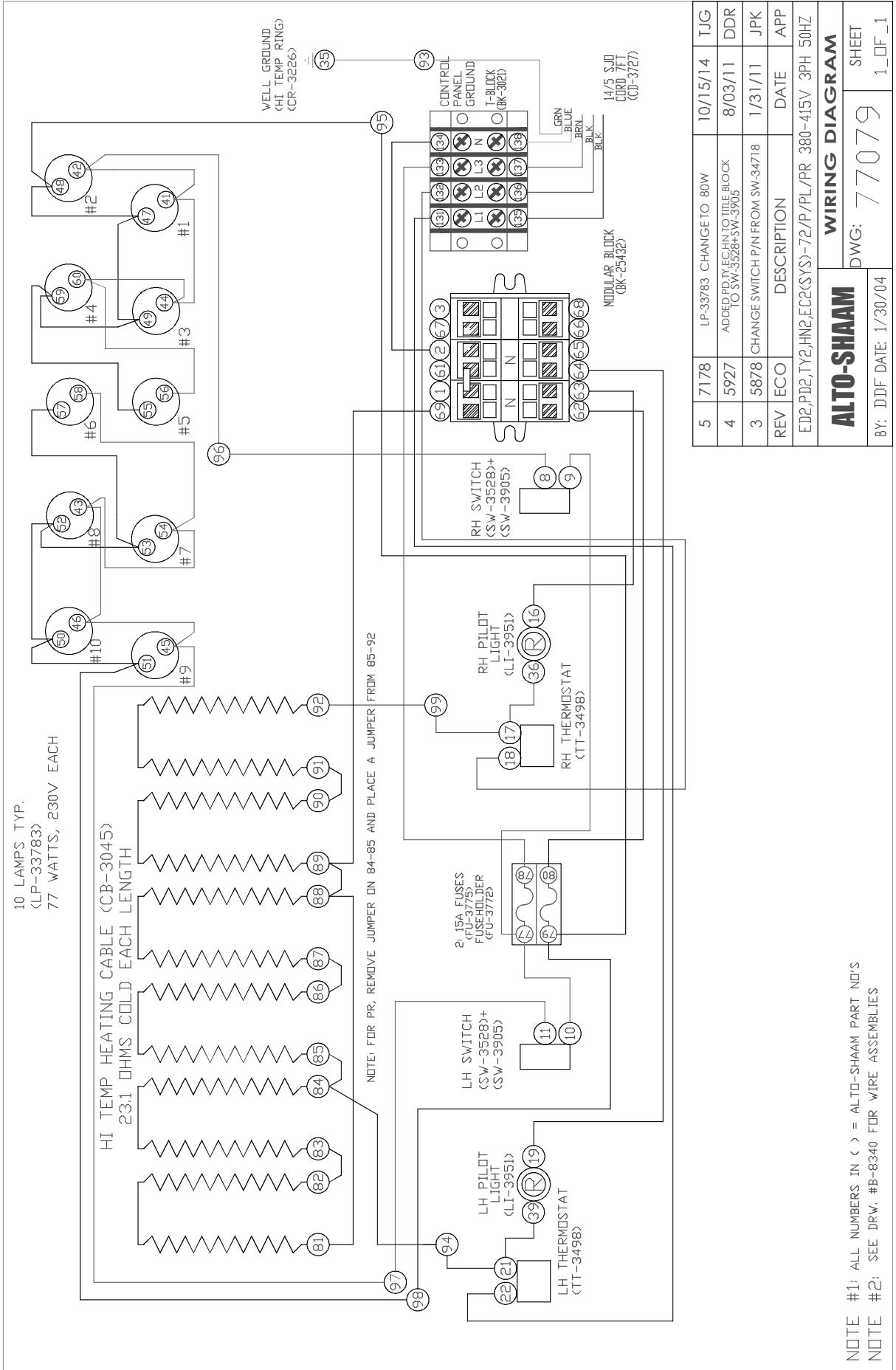

5	7178	LP-33783 CHANGE TO 80W	10/15/14	TJG
4	5927	ADDED PD,TY,EC,HNI TO TITLE BLOCK TO SW-3528+SW-3905	8/03/11	DDR
3	5878	CHANGE SWITCH P/N FROM SW-34718	1/31/11	JKP
REV	ECO	DESCRIPTION	DATE	APP
ED2,PD2,TY2,HN2,EC2(SY)-72/P/PL/PR 380-415V 3PH 50HZ				
ALTO-SHAAM			WIRING DIAGRAM	
BY: DDF DATE: 1/30/04			DWC: 77079	
			SHEET 1_OF_1	

NOTE #1: ALL NUMBERS IN () = ALTO-SHAAM PART NO'S
NOTE #2: SEE DRW. #B-8340 FOR WIRE ASSEMBLIES

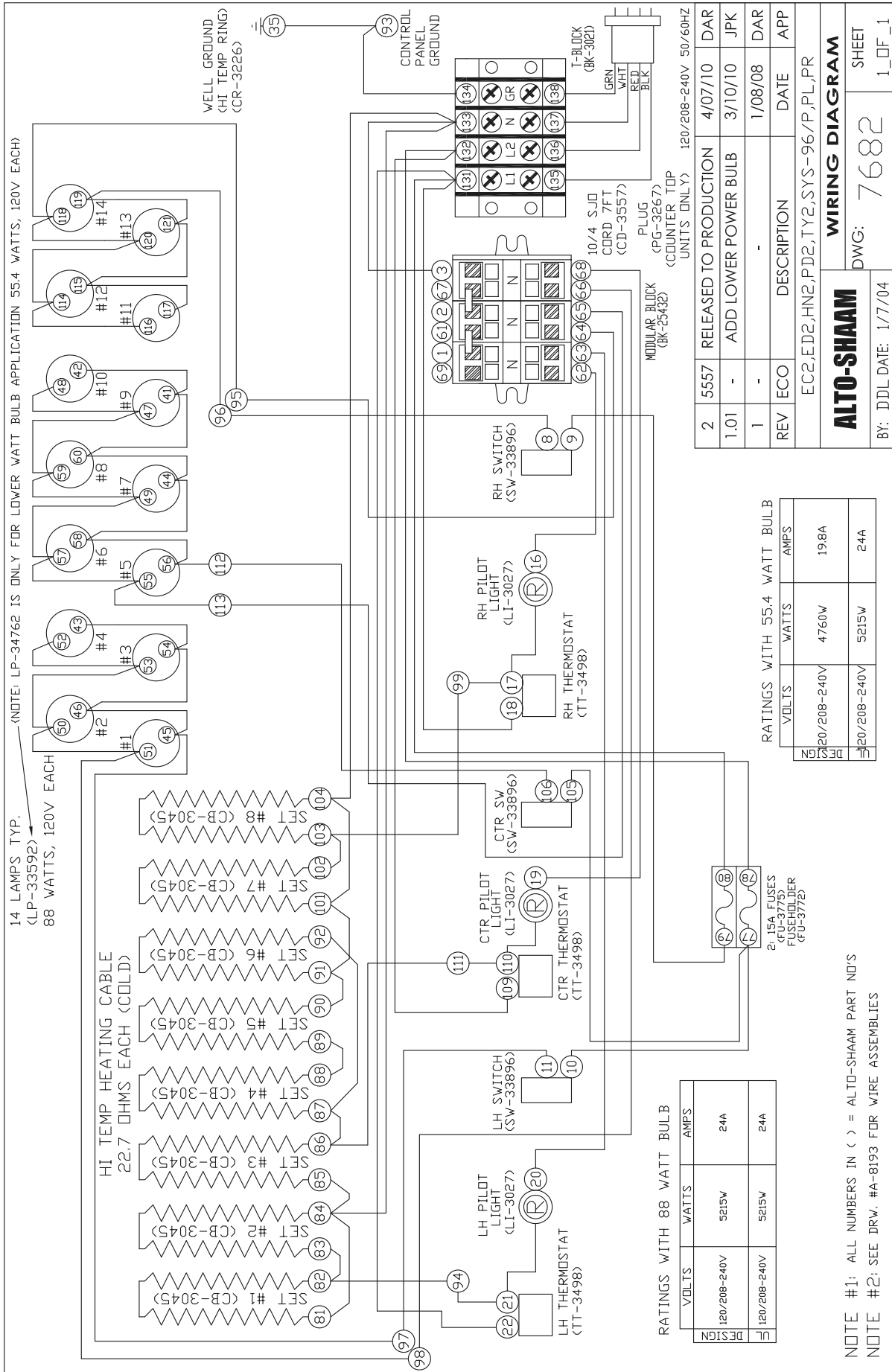

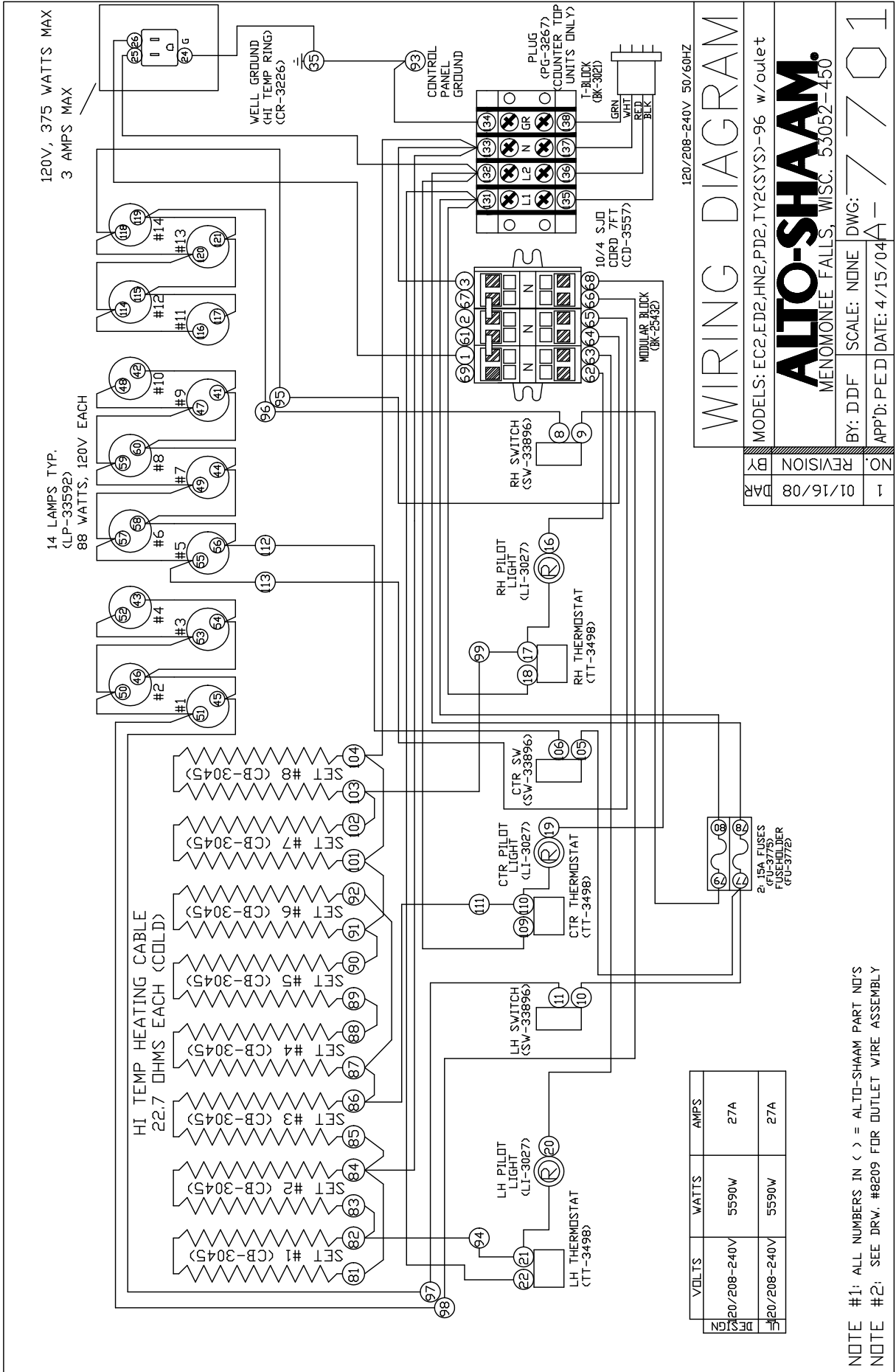

WIRING DIAGRAM

DR		BY		REVISION	
1	01/16/08				
NO.		SCALE:		DWG:	
1	DF	NONE		A-7701	
DATE:		BY:		APP'D:	
4/15/04		DWF		A-7701	

MODELS: EC2, ED2, HN2, PD2, TY2(SYS)-96 w/outlet
ALTO-SHAAM
 MENOMONEE FALLS, WISC. 53052-450

NOTE #1: ALL NUMBERS IN () = ALTO-SHAAM PART NO'S
 NOTE #2: SEE DRW. #8209 FOR OUTLET WIRE ASSEMBLY

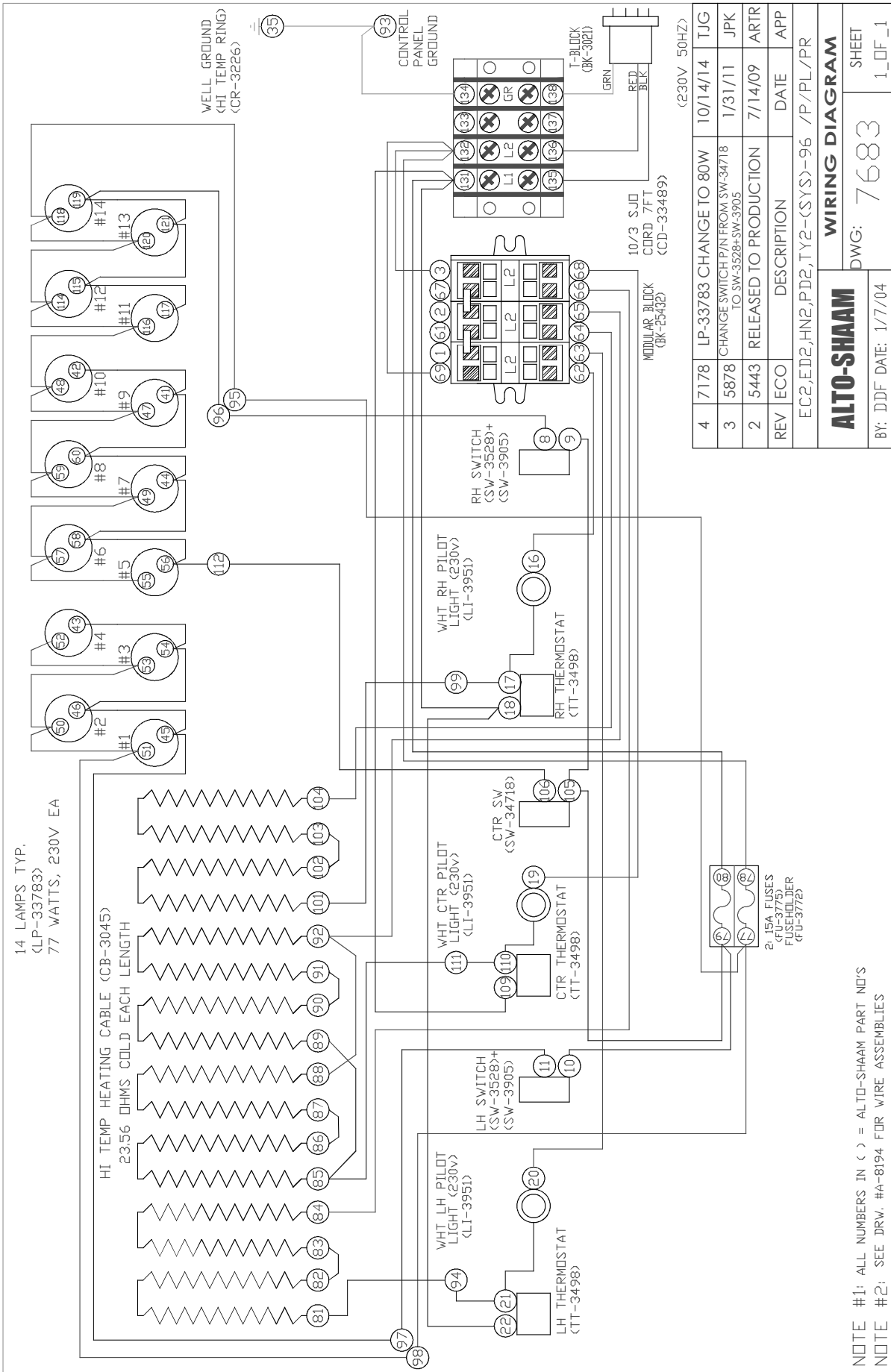

NOTE #1: ALL NUMBERS IN () = ALTO-SHAM PART NO'S
NOTE #2: SEE DRW. #A-8194 FOR WIRE ASSEMBLIES

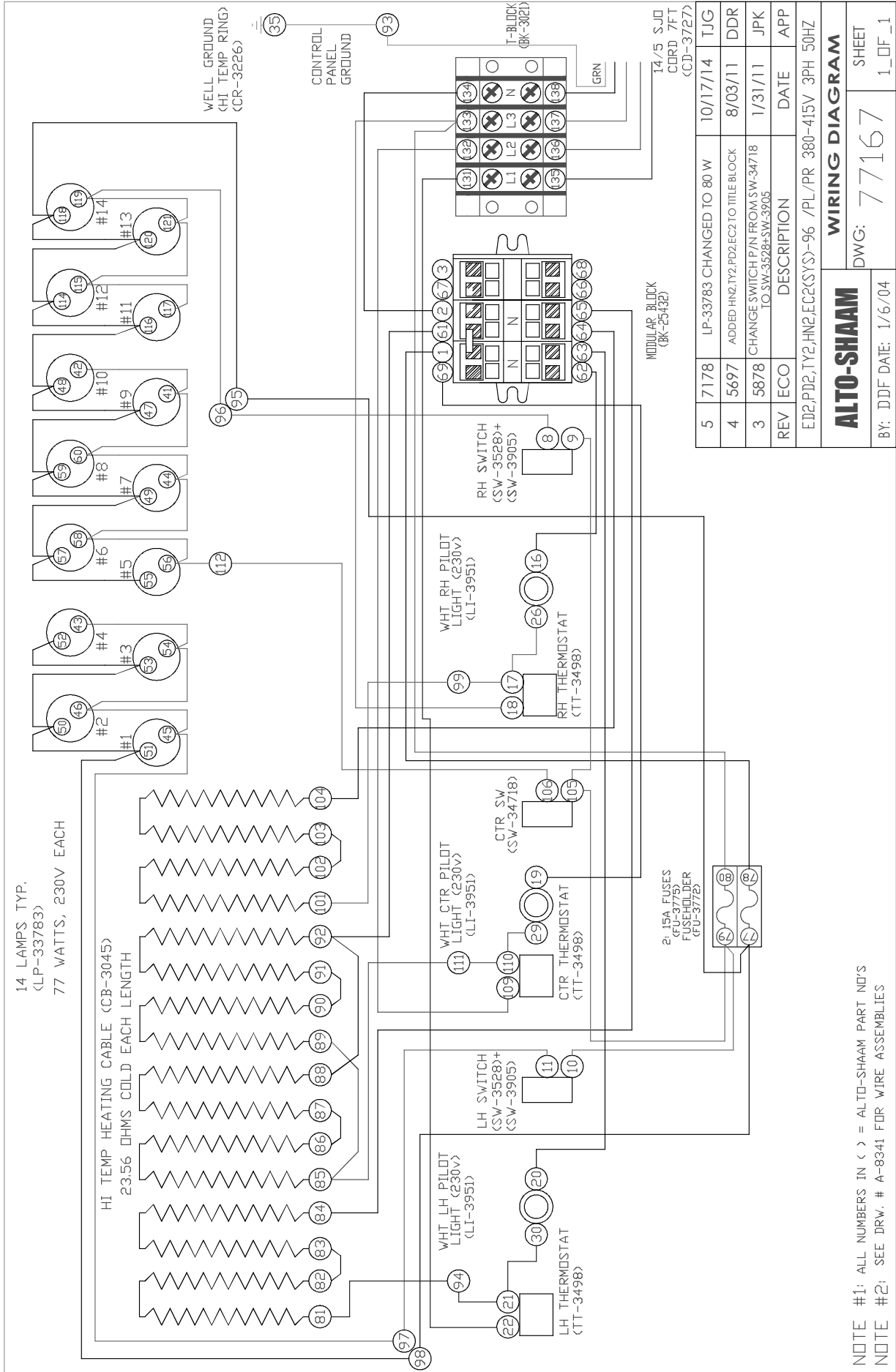

5	7178	LP-33783 CHANGED TO 80 W	10/17/14	TJG
4	5697	ADDED HN2,TY2,PD2,EC2 TO TITLE BLOCK	8/03/11	DDR
3	5878	CHANGE SWITCH P/N FROM SW-34718 TO SW-3528+SW-3905	1/31/11	JFK
REV	ECO	DESCRIPTION	DATE	APP
ED2,PD2,TY2,HN2,EC2(SYS)-96 /PL/PR 380-415V 3PH 50HZ				

ALTO-SHAAM
 DWG: 77167
 SHEET 1_OF_1

WIRING DIAGRAM
 BY: DDF DATE: 1/6/04

NOTE #1: ALL NUMBERS IN () = ALTO-SHAAM PART NO'S
 NOTE #2: SEE DRW. # A-8341 FOR WIRE ASSEMBLIES

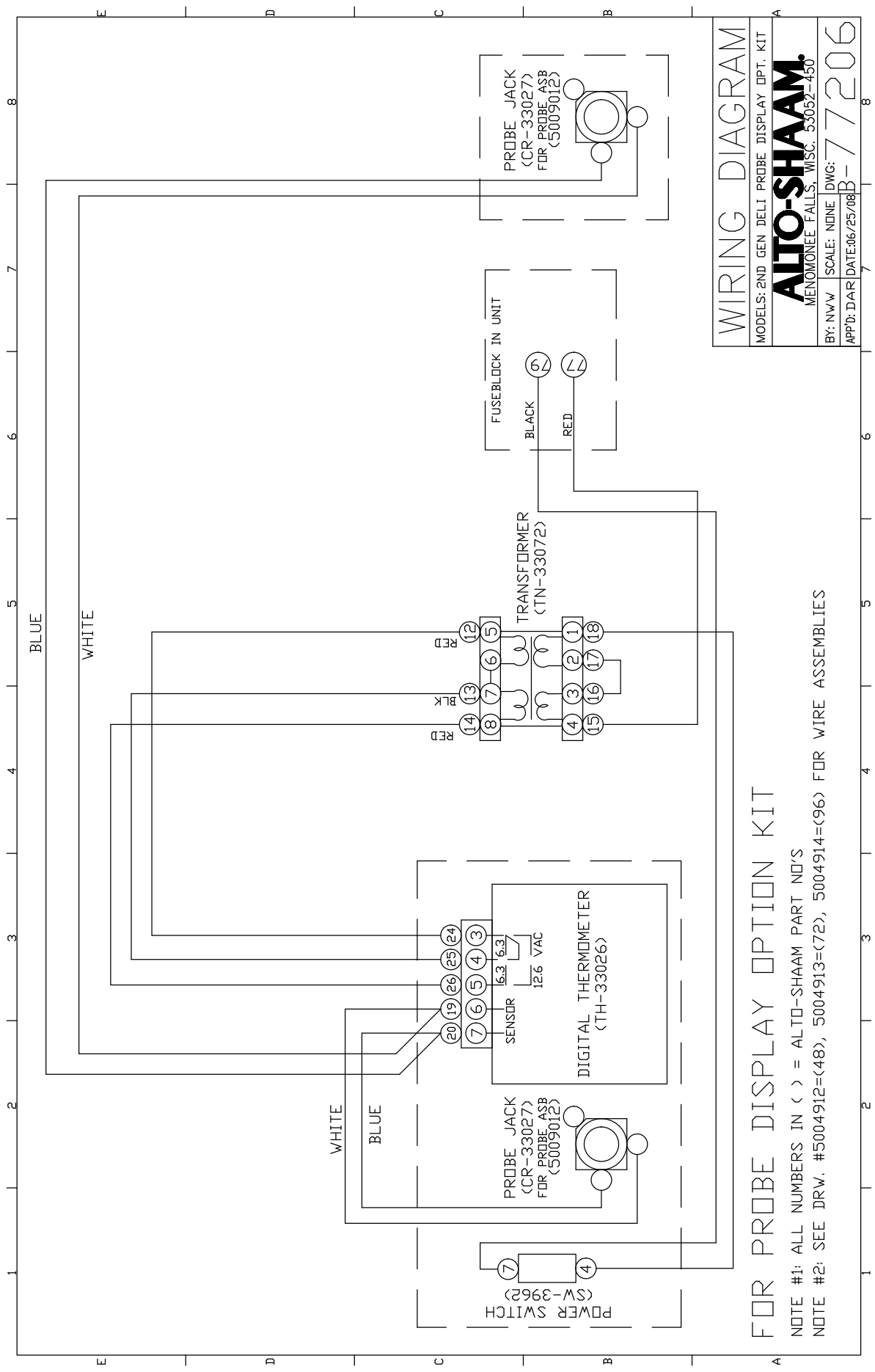

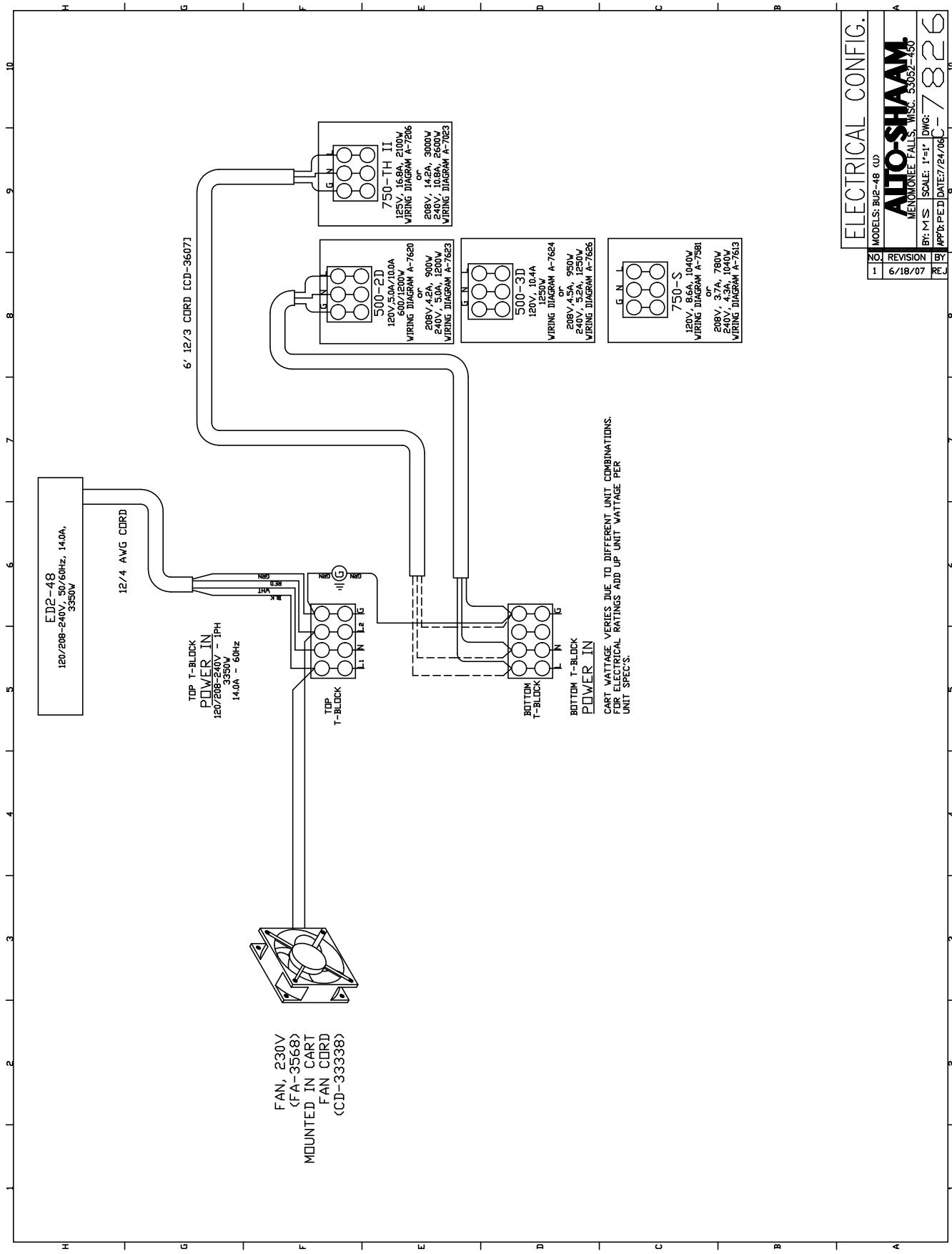

ELECTRICAL CONFIG.

MODELS: BU2-48 (U)

ALTO SHAM
MENOMONEE FALLS, WISCONSIN 53052-1500

BY: M/S SCALE: 1"=1' DWG: C-7826
APP'D: P.E.D. DATE: 7/24/06

NO.	REVISION	BY
1	6/18/07	R.L.

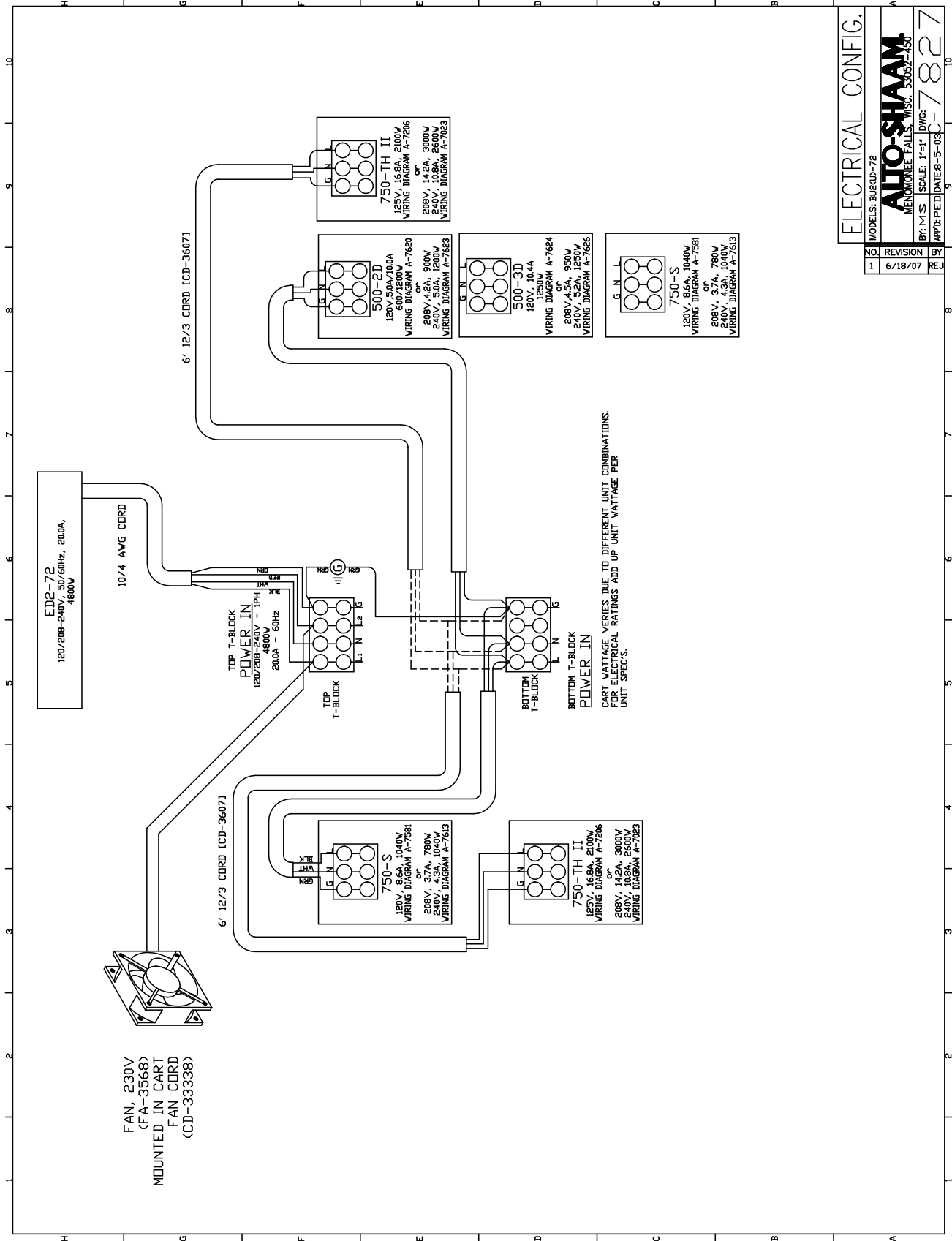

ELECTRICAL CONFIG.

NO.	REVISION	BY
1	6/18/07	RE

MODELS: BU2CU-72
AUTO-SHAAM
 MENDOTA, ILLINOIS 60052-1450
 BR: M/S SCALE: 1"=1' DWG: C-7827
 APP'D: P.E.D. DATE: 6-5-03

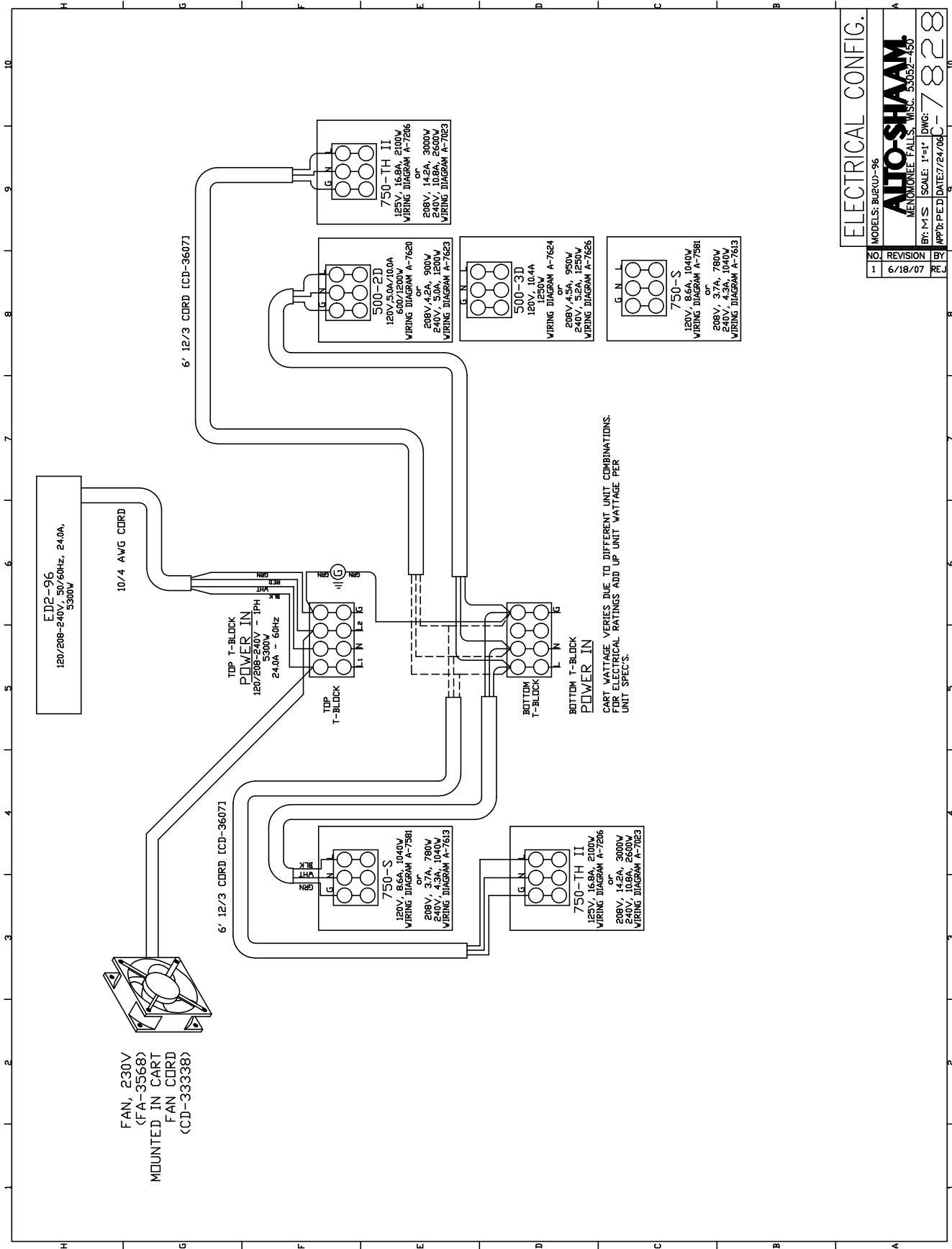

ELECTRICAL CONFIG.

NO	REVISION	DATE	BY
1	6/18/07		

MODELS: BURCU-96
ALTO-SHAAM
 MENOMONEE FALLS, WIS. 53052-4507
 BY: M.S. SCALE: 1"=1' DWG: 7828
 APP'D: PED DATE: 7/24/08 C-7828

TRANSPORTATION DAMAGE and CLAIMS



All Alto-Shaam equipment is sold F.O.B. shipping point, and when accepted by the carrier, such shipments become the property of the consignee.

Should damage occur in shipment, do not put the appliance into service until the damage has been inspected by an authorized Alto-Shaam service provider.

Shipping damages are a matter between the carrier and the consignee. In such cases, the carrier is assumed to be responsible for the safe delivery of the merchandise, unless negligence can be established on the part of the shipper.

1. Make an immediate inspection while the equipment is still in the truck or immediately after it is moved to the receiving area. Do not wait until after the material is moved to a storage area.
2. Do not sign a delivery receipt or a freight bill until you have made a proper count and inspection of all merchandise received.
3. Note all damage to packages directly on the carrier's delivery receipt.
4. Make certain the driver signs this receipt. If he refuses to sign, make a notation of this refusal on the receipt.
5. If the driver refuses to allow inspection, write the following on the delivery receipt:
Driver refuses to allow inspection of containers for visible damage.
6. Telephone the carrier's office immediately upon finding damage, and request an inspection. Mail a written confirmation of the time, date, and the person called.
7. Save any packages and packing material for further inspection by the carrier.
8. Promptly file a written claim with the carrier and attach copies of all supporting paperwork.

We will continue our policy of assisting our customers in collecting claims which have been properly filed and actively pursued. We cannot, however, file any damage claims for you, assume the responsibility of any claims, or accept deductions in payment for such claims.

LIMITED WARRANTY

Alto-Shaam, Inc. warrants to the original purchaser only that any original part that is found to be defective in material or workmanship will, at Alto-Shaam's option, subject to provisions hereinafter stated, be replaced with a new or rebuilt part.

The original parts warranty period is as follows:

For the refrigeration compressor on Alto-Shaam Quickchillers™, five (5) years from the date of installation of appliance.

For the heating element on Halo Heat® cooking and holding ovens, as long as the original purchaser owns the oven. This excludes holding only equipment.

For all other original parts, one (1) year from the date of installation of appliance or fifteen (15) months from the shipping date, whichever occurs first.

The labor warranty period is one (1) year from the date of installation or fifteen (15) months from the shipping date, whichever occurs first.

Alto-Shaam will bear normal labor charges performed during standard business hours, excluding overtime, holiday rates or any additional fees.

To be valid, a warranty claim must be asserted during the applicable warranty period. This warranty is not transferable.

THIS WARRANTY DOES NOT APPLY TO:

1. Calibration.
2. Replacement of light bulbs, door gaskets, and/or the replacement of glass due to damage of any kind.
3. Equipment damage caused by accident, shipping, improper installation or alteration.
4. Equipment used under conditions of abuse, misuse, carelessness or abnormal conditions, including but not limited to, equipment subjected to harsh or inappropriate chemicals, including but not limited to, compounds containing chloride or quaternary salts, poor water quality, or equipment with missing or altered serial numbers.
5. Damage incurred as a direct result of poor water quality, inadequate maintenance of steam generators and/or surfaces affected by water quality. Water quality and required maintenance of steam generating equipment is the responsibility of the owner/operator.
6. Damage caused by use of any cleaning agent other than Alto-Shaam's Combitherm® Cleaner, including but not limited to damage due to chlorine or other harmful chemicals. **Use of Alto-Shaam's Combitherm® Cleaner on Combitherm® ovens is highly recommended.**
7. Any losses or damage resulting from malfunction, including loss of product, food product, revenue, or consequential or incidental damages of any kind.
8. Equipment modified in any manner from original model, substitution of parts other than factory authorized parts, removal of any parts including legs, or addition of any parts.

This warranty is exclusive and is in lieu of all other warranties, express or implied, including the implied warranties of merchantability and fitness for a particular purpose. In no event shall Alto-Shaam be liable for loss of use, loss of revenue or profit, or loss of product, or for any indirect, special, incidental, or consequential damages. No person except an officer of Alto-Shaam, Inc. is authorized to modify this warranty or to incur on behalf of Alto-Shaam any other obligation or liability in connection with Alto-Shaam equipment.

ALTO-SHAAM.

Effective November 1, 2012

W164 N9221 Water Street • P.O. Box 450
Menomonee Falls, Wisconsin 53052-0450 U.S.A.

PHONE: 262.251.3800 • 800.558.8744 U.S.A. / CANADA

FAX: 262.251.7067 • 800.329.8744 U.S.A. ONLY

www.alto-shaam.com

PRINTED IN U.S.A.