



ISLAND TAKEOUT MERCHANDISER



ITM2-48/STD



ITM2-72/STD

Models:

ITM2-48/STD

ITM2-48/DLX

ITM2-48/CT

ITM2-72/STD

ITM2-72/DLX

ITM2-72/CT

- **INSTALLATION**
- **OPERATION**
- **MAINTENANCE**

W164 N9221 Water Street • P.O. Box 450
Menomonee Falls, Wisconsin 53052-0450 U.S.A.

PHONE: 262.251.3800 • 800.558.8744 U.S.A. / CANADA
FAX: 262.251.7067 • 800.329.8744 U.S.A. ONLY
www.alto-shaam.com



Consult instructions
for operation and use.





Delivery 1
Unpacking 1
Safety Procedures and Precautions 2

Installation

Installation Requirements 4
Leveling 4
Dimension Drawings, Weights & Capacities 5-6
Options and Accessories 6
Electrical Specifications 7

Operating Instructions

User Safety Information 8
Start-up Operation 8
Operating Procedures 8
General Holding Guidelines 9

Care and Cleaning

Cleaning and Preventative Maintenance 10
Protecting Stainless Steel Surfaces 10
Cleaning Agents 10
Cleaning Materials 10
Equipment Care 11
Clean Daily 11

Sanitation

Sanitation/Food Safety 12
Internal Food Product Temperatures 12

Service

Exterior Service View & Parts 13-16

Wire Diagrams

Always refer to the wire diagram(s) included with the unit for most current version.

Warranty

Transportation Damage and Claims Back Cover
Limited Warranty Back Cover



DELIVERY

This Alto-Shaam appliance has been thoroughly tested and inspected to ensure only the highest quality unit is provided. Upon receipt, check for any possible shipping damage and report it at once to the delivering carrier. *See Transportation Damage and Claims section located in this manual.*

This appliance, complete with unattached items and accessories, may have been delivered in one or more packages. Check to ensure that all standard items and options have been received with each model as ordered.

Save all the information and instructions packed with the appliance. Register online at www.alto-shaam.com or complete and return the warranty card to the factory as soon as possible to ensure prompt service in the event of a warranty parts and labor claim.

This manual must be read and understood by all people using or installing the equipment model. Contact the Alto-Shaam Tech Team Service Department if you have any questions concerning installation, operation, or maintenance.

NOTICE: All claims for warranty must include the full model number and serial number of the appliance.

WARNING



Appliance and accessories may be heavy. To prevent serious injury, ALWAYS use a sufficient number of trained and experienced workers when moving or leveling appliance and handling accessories.

ENVIRONMENTAL CONDITIONS

- Operational Environmental Conditions
- Unit must acclimate to room temperature in the environment it is placed. 24 hours is recommended.
- Ambient temperature range of 50° to 110°F (10° to 43°C).
- Relative humidity of less than 95% non-condensation.
- Atmospheric pressure range of 50KPa to 106KPa.

UNPACKING

- Carefully remove the appliance from the carton or crate.

NOTICE: Do not discard the carton and other packaging material until you have inspected the unit for hidden damage and tested it for proper operation.

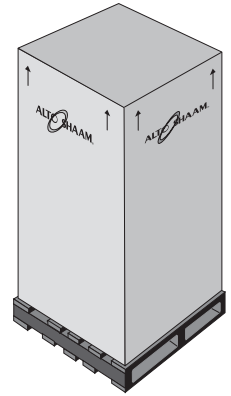

- Read all instructions in this manual carefully before initiating the installation of this appliance, using the appliance or performing routine maintenance. Following procedures other than those indicated in this guide to use and clean the appliance is considered inappropriate and may cause damage, injury or fatal accidents, in addition to invalidating the guarantee and relieving Alto-Shaam of all liability.
- DO NOT DISCARD THIS MANUAL. This manual is considered to be part of the appliance and is to be provided to the owner or manager of the business or to the person responsible for training operators. *Additional manuals are available from the Alto-Shaam Tech Team Service Department.*
- Remove all protective plastic film, packaging materials, and accessories from the appliance before connecting electrical power. Store any accessories in a convenient place for future use.

SAFETY PROCEDURES AND PRECAUTIONS

Knowledge of proper procedures is essential to the safe operation of electrically and/or gas energized equipment. In accordance with generally accepted product safety labeling guidelines for potential hazards, the following signal words and symbols may be used throughout this manual.

DANGER



Used to indicate the presence of a hazard that **WILL** cause severe personal injury, death, or substantial property damage if the warning included with this symbol is ignored.

WARNING



Used to indicate the presence of a hazard that **CAN** cause personal injury, possible death, or major property damage if the warning included with this symbol is ignored.

CAUTION



Used to indicate the presence of a hazard that can or will cause minor or moderate personal injury or property damage if the warning included with this symbol is ignored.

CAUTION

Used to indicate the presence of a hazard that can or will cause minor personal injury, property damage, or a potential unsafe practice if the warning included with this symbol is ignored.

NOTICE: Used to notify personnel of installation, operation, or maintenance information that is important but not hazard related.



Used to indicate that referral to operating instructions is a mandatory action. If not followed the operator could suffer personal injury.



Used to indicate that referral to operating instructions is recommended to understand operation of equipment.

- This appliance is intended to cook, hold or process foods for the purpose of human consumption. No other use for this appliance is authorized and is therefore considered dangerous. The appliance must not be used to cook food containing flammable materials (such as food with alcohol). Substances with a low flash point can ignite spontaneously and cause a fire.
- This appliance is intended for use in commercial establishments where all operators are familiar with the purpose, limitations, and associated hazards of this appliance. Operating instructions and warnings must be read and understood by all operators and users. We recommend regular training of your staff to avoid the risk of accident or damage to the unit. Operators must also receive regular safety instructions.
- Any troubleshooting guides, component views, and parts lists included in this manual are for general reference only and are intended for use by qualified and trained technicians.
- This manual should be considered a permanent part of this appliance. This manual and all supplied instructions, diagrams, schematics, parts lists, notices, and labels must remain with the appliance if the item is sold or moved to another location.

NOTICE



For equipment delivered for use in any location regulated by the following directive:

DO NOT dispose of electrical or electronic equipment with other municipal waste.

ADDITIONAL SAFETY PROCEDURES AND PRECAUTIONS

- To prevent serious injury, death or property damage, your appliance should be inspected and serviced at least every twelve (12) months by an authorized service partner or trained technician.
- ONLY allow an authorized service partner or trained technician to service or to repair your appliance. Installation or repairs that are not performed by an authorized service partner or trained technician, or the use of non-factory authorized parts will void the warranty and relieve Alto-Shaam of all liability.
- When working on this appliance, observe precautions in the literature, on tags, on labels attached to or shipped with the appliance and other safety precautions that may apply.
- If the appliance is installed on casters freedom of movement of the appliance must be restricted so that utility connections (including gas, water, and electricity) cannot be damaged when the unit is moved. If the appliance is moved, make sure that all utility connections are properly disconnected. If the unit is returned to its original position, make sure that any retention devices and utility connections are properly connected.
- ONLY use the appliance when it is stationary. Mobile oven racks, mobile plate racks, transport trolleys, and appliances on casters can tip over when being moved over an uneven floor or threshold and cause serious injury.
- ALWAYS apply caster brakes on mobile appliances or accessories when these are not being moved. These items could move or roll on uneven floors and cause property damage or serious injury.
- Be extremely careful when moving appliances because the food trays may contain hot fluids that may spill, causing serious injury.
- ALWAYS open the appliance door very slowly. Escaping hot vapors or steam can cause serious injury or death.
- If your gas appliance is installed under an exhaust hood, the hood must be switched ON when the oven is in use to avoid the build up of combustion gases. Failure to do so may result in serious injury, death or property damage.
- NEVER place objects near the oven exhaust vents. This area is hot and could be a potential ignition source for a fire.
- Do not allow objects to block or obstruct the area below the oven base. This may result in fire, damage to the equipment or serious injury.
- Do not use the attached hand-held hose to spray anything other than the interior of the oven compartment.
- Do not use the attached hand-held hose on the surface of a hot cooking compartment. The sudden temperature change can damage the oven interior. Allow the oven to cool to a minimum of 150°F (66°C). Failure to observe this precaution can void the warranty.

WARNING



This appliance is not intended for use by persons (including children) with reduced physical, sensory or mental capabilities, or lack of experience and knowledge, unless they have been given supervision concerning use of the appliance by person responsible for their safety.

Children should be supervised to ensure that they do not play with the appliance.

INSTALLATION

SITE INSTALLATION

WARNING



Improper installation, alteration, adjustment, service, cleaning, or maintenance could result in property damage, severe injury, or death.

READ and **UNDERSTAND** the installation, operating and maintenance instructions thoroughly before installing, servicing, or operating this equipment.

WARNING



Appliance and accessories may be heavy. To prevent serious injury, **ALWAYS** use a sufficient number of trained and experienced workers when moving or leveling appliance and handling accessories.

CAUTION



To prevent **SEVERE PERSONAL INJURY** or **PROPERTY DAMAGE**:

ALWAYS use hand protection when operating this appliance to avoid burns. Metal parts of this equipment become extremely hot when in operation.

CAUTION



The performance of this unit has been optimized using the factory provided bulbs. These bulbs should be replaced with an exact replacement or with a factory recommended replacement. These bulbs have been treated to resist breakage and must be replaced with similarly treated bulbs in order to maintain compliance with NSF standards. **DO NOT** over-tighten bulbs in their receptacles as this may cause damage to the bulb filament.

SITE INSTALLATION

In order to maintain established National Sanitation Foundation standards, all stationary floor models must be sealed to the floor with a R.T.V. or silastic meeting N.S.F. requirements or have 6" (153mm) unobstructed clearance beneath the unit.

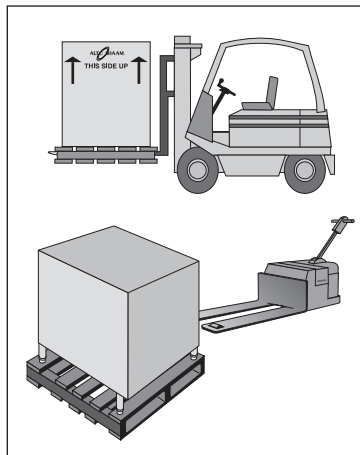

1. The appliance must be installed on a stable and level surface.
2. **DO NOT** install this appliance in any area where it may be affected by any adverse conditions such as steam, grease, dripping water, high temperatures, or any other severely adverse conditions.
3. **DO NOT** install a heated display case near a cold air source such as a freezer, air conditioning vents, or in any area where outside air fluctuation can affect performance.
4. This appliance must be kept free and clear of any obstructions blocking access for maintenance or service.

A number of adjustments are associated with initial installation and start-up. It is important that these adjustments be conducted by a qualified service technician. Installation and start-up adjustments are the responsibility of the dealer or user. These adjustments include but are not limited to thermostat calibration, door adjustment, leveling, electrical hook-up and installation of optional casters or legs.

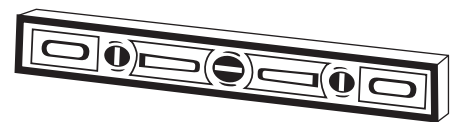

LEVELING

Level the appliance from side-to-side and front-to-back with the use of a spirit level.

We recommend checking the level periodically to make certain the floor has not shifted nor the appliance moved.

NOTICE: Failure to properly level this appliance can cause improper function.

INSTALLATION

SITE INSTALLATION

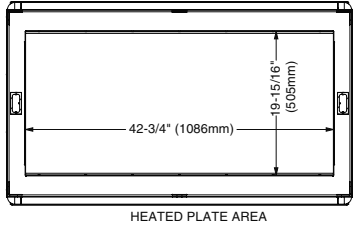

HEATED PLATE AREA

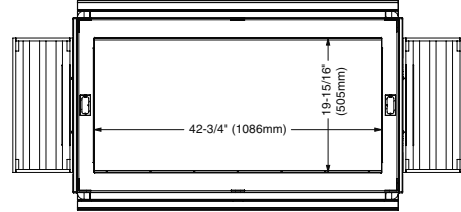

HEATED PLATE AREA

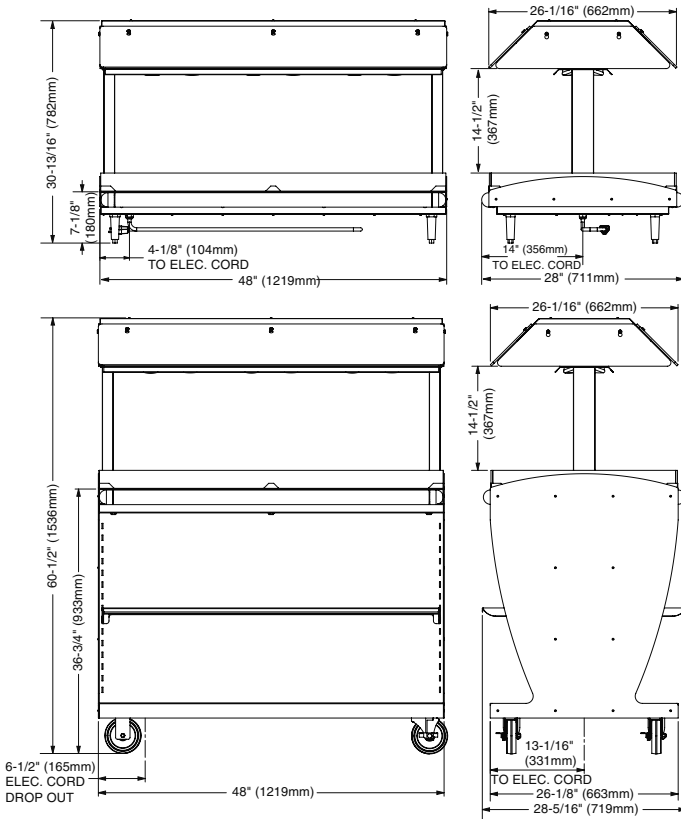

ITM2-48/STD

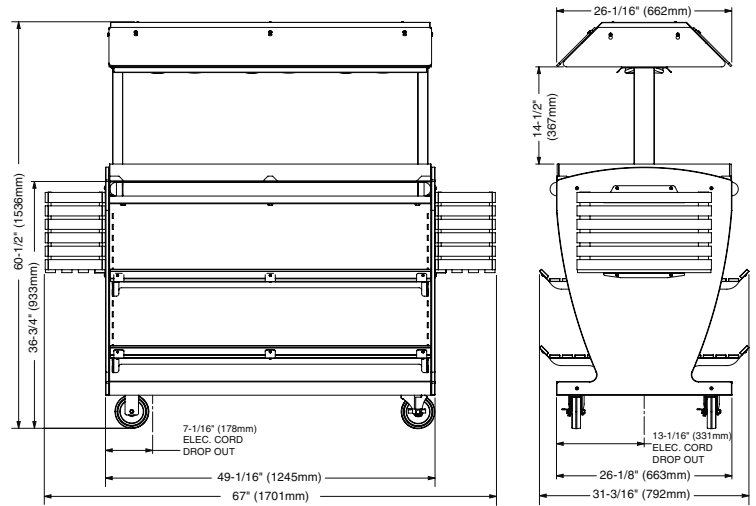

ITM2-48/DLX

HEATED PRODUCT CAPACITY*

36 lb (16 kg) MAXIMUM
 Twelve (12) chicken boats with dome cover
 DOME PACKAGE SIZE: APPROX. 7" x 10" (178mm x 254mm)

*FOR USE WITH PRE-PACKAGED ITEMS ONLY

OPTIONS AND ACCESSORIES

	ITM2-48/STD	ITM2-48/DLX
Stainless Steel Panels	5007905	5007907
Custom Color Panels	5007906	5007908
Full Side Guards, Lexan	5007917	5007917

INSTALLATION

SITE INSTALLATION

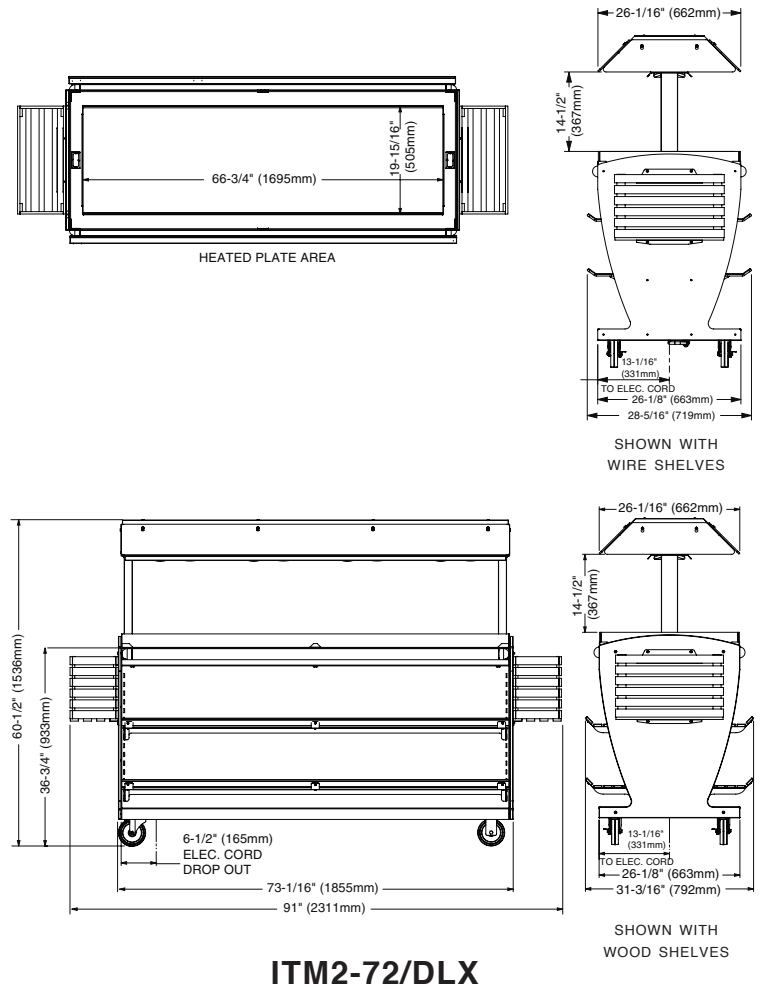
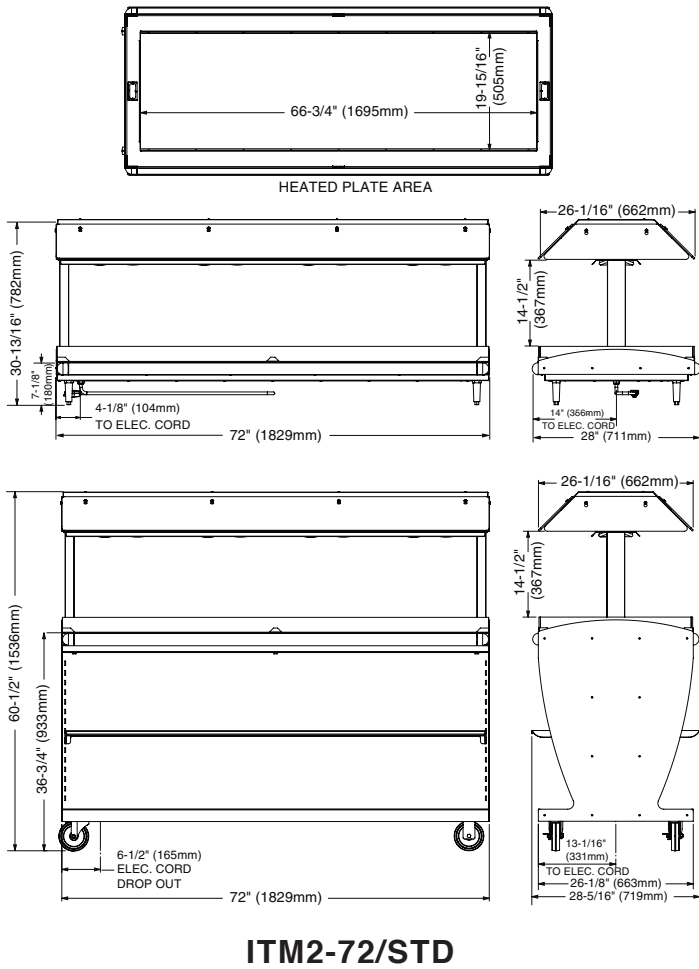

HEATED PRODUCT CAPACITY*

63 lb (29 kg) MAXIMUM
Twenty-one (21) chicken boats with dome cover
DOME PACKAGE SIZE: APPROX. 7" x 10" (178mm x 254mm)

*FOR USE WITH PRE-PACKAGED ITEMS ONLY

OPTIONS AND ACCESSORIES

	ITM2-72/STD	ITM2-72/DLX
Stainless Steel Panels	5007911	5007913
Custom Color Panels	5007912	5007914
Full Side Guards, Lexan	5007917	5007917

INSTALLATION

ELECTRICAL CONNECTION

The appliance must be installed by a qualified service technician. The oven must be properly grounded in accordance with the National Electrical Code and applicable local codes.

WARNING



To prevent **SERIOUS INJURY, DEATH, or PROPERTY DAMAGE:**

All electrical connections must be made by a qualified and trained service technician in accordance with applicable electrical codes.



This appliance **MUST** be adequately grounded in accordance with local electrical codes or, in the absence of local codes, with the current edition of the National Electrical Code ANSI/NFPA No. 70. In Canada, all electrical connections are to be made in accordance with CSA C22.1, Canadian Electrical Code Part 1 or local codes.

Plug the unit into a properly grounded receptacle **ONLY**, positioning the unit so that the plug is easily accessible in case of an emergency. Arcing will occur when connecting or disconnecting the unit unless all controls are in the "OFF" position.

Proper receptacle or outlet configuration or permanent wiring for this unit must be installed by a licensed electrician in accordance with applicable local electrical codes.

ITM2-48 ELECTRICAL

VOLTAGE	PHASE	CYCLE/HZ	AMPS	kw	PLUG CONFIGURATION
120	1	50/60	11	1.3	 NEMA 5-15P 15A - 125V PLUG
230	1	50	7.5	1.7	CORD, NO PLUG

ITM2-72 ELECTRICAL

VOLTAGE	PHASE	CYCLE/HZ	AMPS	kw	PLUG CONFIGURATION
120	1	50/60	16	1.9	 NEMA 5-20P 20A - 125V PLUG
230	1	50	10.6	2.4	CORD, NO PLUG

Wire diagrams are included in the literature package supplied with the unit.

WARNING



To prevent **SERIOUS INJURY, DEATH or PROPERTY DAMAGE:**

All electrical connections must be made by a qualified and trained service technician in accordance with applicable electrical codes.

DANGER



Ensure power source matches voltage identified on appliance rating tag. The rating tag provides essential technical information required for any appliance installation, maintenance or repairs. Do not remove, damage or modify the rating tag.

REGARDING INTERNATIONAL STANDARD UNITS:

If the unit is not equipped with flexible cord with plug, an all-pole country approved disconnection device which has a contact separation of at least 3mm in all poles must be incorporated in the fixed wiring for disconnection. When using a cord without a plug, the green/yellow conductor shall be connected to the terminal which is marked with the ground symbol. If a plug is used, the socket outlet must be easily accessible. If the power cord needs replacement, use a similar one obtained from the distributor.



For CE approved units: To prevent an electrical shock hazard between the appliance and other appliances or metal parts in close vicinity, an equalization-bonding stud is provided. An equalization bonding lead must be connected to this stud and the other appliances/metal parts to provide sufficient protection against potential difference. The terminal is marked with the following symbol.



OPERATION

USER SAFETY INFORMATION

USER SAFETY INFORMATION:

This appliance is intended for use in commercial establishments by qualified personnel who are familiar with the purpose, limitations, and associated hazards of this appliance. Operating instructions and warnings must be read and understood by all operators and users.

CAUTION



To prevent **SEVERE PERSONAL INJURY** or **PROPERTY DAMAGE**:
ALWAYS use hand protection when operating this appliance to avoid burns. Metal parts of this equipment become extremely hot when in operation.

START UP

BEFORE INITIAL USE:

Before operating the unit, clean both the interior and exterior of the unit with a damp cloth and mild soap solution. Rinse well.

Merchandise heat plate must be heated to remove surface oils and the accompanying odor produced during the first use of the appliance.

Turn ON/OFF toggle switch to ON position. Turn LOW/MED/HIGH toggle switch to HIGH. Allow the unit to heat for 30 minutes or until no odor is detected.

WARNING



To prevent **SERIOUS INJURY, DEATH, OR PROPERTY DAMAGE**, **ALWAYS** disconnect unit from power source before cleaning or servicing.

OPERATING PROCEDURES

1. Set toggle switch.

Turn toggle switch to "ON" position. Lights will illuminate and heat plate will begin to warm.

Set 3-way toggle switch to desired holding temperature (LOW/MED/HIGH).

2. Preheat:

Preheat for a minimum of 30 minutes before loading food.

3. Load prepackaged hot foods into the merchandiser.

Before loading food into the unit, use a pocket-type meat thermometer to make certain all products have reached an internal temperature of 160°F (71°C) or higher. If any food product is not at proper serving temperature, use a Halo Heat cooking and holding oven or Combitherm Oven to bring the product within the correct temperature range.

- ✓ Use hand protection when handling hot items.
- ✓ Do not stack food containers.
- ✓ Be certain only hot PREPACKAGED foods in appropriate heat tested containers are used in this hot display case.

4. Check food temperature.

Since proper temperature range depends on the type of products and the quantities being held, it is necessary to periodically use a pocket thermometer to check each item to make certain the correct temperatures are being maintained. Local health regulations may vary regarding minimum serving temperatures. Proper temperature range is usually 160°F (71°C) or higher.

AVERAGE Heat Plate Temperature:

Setting	Temperature
Low	200°F (93°C)
Med	225°F (107°C)
High	250°F (121°C)

OPERATION

GENERAL HOLDING GUIDELINES

Chefs, cooks and other specialized food service personnel employ varied methods of cooking. Proper holding temperatures for a specific food product must be based on the moisture content of the product, product density, volume, and proper serving temperatures. Safe holding temperatures must also be correlated with palatability in determining the length of holding time for a specific product.

Halo Heat maintains the maximum amount of product moisture content without the addition of water, water vapor, or steam. Maintaining maximum natural product moisture preserves the natural flavor of the product and provides a more genuine taste. In addition to product moisture retention, the gentle properties of Halo Heat maintain a consistent temperature throughout the cabinet without the necessity of a heat distribution fan, thereby preventing further moisture loss due to evaporation or dehydration.

When product is removed from a high temperature cooking environment for immediate transfer into equipment with the lower temperature required for hot food holding, condensation can form on the outside of the product and on the inside of plastic containers used in self-service applications. Allowing the product to release the initial steam and heat produced by high temperature cooking can alleviate this condition. To preserve the safety and quality of freshly cooked foods however, a maximum of 1 to 2 minutes must be the only time period allowed for the initial heat to be released from the product.

Use a metal-stemmed thermometer to measure the internal temperature of the product being held. Adjust the thermostat setting to achieve the best overall setting based on internal product temperature.

HOLDING TEMPERATURE RANGE		
MEAT	FAHRENHEIT	CELSIUS
BEEF ROAST — Rare	130°F	54°C
BEEF ROAST — Med/Well Done	155°F	68°C
BEEF BRISKET	160°F — 175°F	71°C — 79°C
CORN BEEF	160°F — 175°F	71°C — 79°C
PASTRAMI	160°F — 175°F	71°C — 79°C
PRIME RIB — Rare	130°F	54°C
STEAKS — Broiled/Fried	140°F — 160°F	60°C — 71°C
RIBS — Beef or Pork	160°F	71°C
VEAL	160°F — 175°F	71°C — 79°C
HAM	160°F — 175°F	71°C — 79°C
PORK	160°F — 175°F	71°C — 79°C
LAMB	160°F — 175°F	71°C — 79°C
POULTRY		
CHICKEN — Fried/Baked	160°F — 175°F	71°C — 79°C
DUCK	160°F — 175°F	71°C — 79°C
TURKEY	160°F — 175°F	71°C — 79°C
GENERAL	160°F — 175°F	71°C — 79°C
FISH/SEAFOOD		
FISH — Baked/Fried	160°F — 175°F	71°C — 79°C
LOBSTER	160°F — 175°F	71°C — 79°C
SHRIMP — Fried	160°F — 175°F	71°C — 79°C
BAKED GOODS		
BREADS/ROLLS	120°F — 140°F	49°C — 60°C
MISCELLANEOUS		
CASSEROLES	160°F — 175°F	71°C — 79°C
DOUGH — Proofing	80°F — 100°F	27°C — 38°C
EGGS — Fried	150°F — 160°F	66°C — 71°C
FROZEN ENTREES	160°F — 175°F	71°C — 79°C
HORS D'OEUVRES	160°F — 180°F	71°C — 82°C
PASTA	160°F — 180°F	71°C — 82°C
PIZZA	160°F — 180°F	71°C — 82°C
POTATOES	180°F	82°C
PLATED MEALS	140°F — 165°F	60°C — 74°C
SAUCES	140°F — 200°F	60°C — 93°C
SOUP	140°F — 200°F	60°C — 93°C
VEGETABLES	160°F — 175°F	71°C — 79°C
THE HOLDING TEMPERATURES LISTED ARE SUGGESTED GUIDELINES ONLY. ALL FOOD HOLDING SHOULD BE BASED ON INTERNAL PRODUCT TEMPERATURES. ALWAYS FOLLOW LOCAL HEALTH (HYGIENE) REGULATIONS FOR ALL INTERNAL TEMPERATURE REQUIREMENTS.		

CARE AND CLEANING

CLEANING AND PREVENTATIVE MAINTENANCE

PROTECTING STAINLESS STEEL SURFACES



It is important to guard against corrosion in the care of stainless steel surfaces. Harsh, corrosive, or inappropriate chemicals can completely destroy the protective surface layer of stainless steel. Abrasive

pads, steel wool, or metal implements will abrade surfaces causing damage to this protective coating and will eventually result in areas of corrosion. Even water, particularly hard water that contains high to moderate concentrations of chloride, will cause oxidation and pitting that result in rust and corrosion. In addition, many acidic foods spilled and left to remain on metal surfaces are contributing factors that will corrode surfaces.

Proper cleaning agents, materials, and methods are vital to maintaining the appearance and life of this appliance. Spilled foods should be removed and the area wiped as soon as possible but at the very least, a minimum of once a day. Always thoroughly rinse surfaces after using a cleaning agent and wipe standing water as quickly as possible after rinsing.

CLEANING AGENTS

Use non-abrasive cleaning products designed for use on stainless steel surfaces. Cleaning agents must be chloride-free compounds and must not contain quaternary salts. Never use hydrochloric acid (muriatic acid) on stainless steel surfaces. Always use the proper cleaning agent at the manufacturer's recommended strength. Contact your local cleaning supplier for product recommendations.

CLEANING MATERIALS

The cleaning function can usually be accomplished with the proper cleaning agent and a soft, clean cloth. When more aggressive methods must be employed, use a non-abrasive scouring pad on difficult areas and make certain to scrub with the visible grain of surface metal to avoid surface scratches. Never use wire brushes, metal scouring pads, or scrapers to remove food residue.

CAUTION



To protect stainless steel surfaces, completely avoid the use of abrasive cleaning compounds, chloride based cleaners, or cleaners containing quaternary salts. **NEVER** use hydrochloric acid (muriatic acid) on stainless steel. **NEVER** use wire brushes, metal scouring pads or scrapers.

WARNING



To prevent **SERIOUS INJURY, DEATH, or PROPERTY DAMAGE:**

The appliance must be cleaned thoroughly to avoid deposits of grease and or food residues inside the appliance that may catch fire. If fat deposits and/or food waste inside the appliance ignite, shut down the appliance immediately and keep the appliance door closed to extinguish the fire. If further extinguishing is required, disconnect the appliance from the main power and use a fire extinguisher (do not use water to extinguish a grease fire!). Failure to clean the appliance properly invalidates the warranty and relieves Alto-Shaam of all liability.

CARE AND CLEANING

EQUIPMENT CARE

The cleanliness and appearance of this equipment will contribute considerably to operating efficiency and savory, appetizing food.

Good equipment that is kept clean works better and lasts longer.



THOROUGHLY CLEAN THE APPLIANCE DAILY

1. Remove food from merchandiser.
2. Turn ON/OFF toggle switch to the "OFF" position. Disconnect unit from power source. Let the unit cool.
3. Clean heat plate and metal surfaces of the unit with a damp, clean cloth and any good commercial detergent at the recommended strength. Use a plastic scouring pad or oven cleaner for difficult areas. Rinse surfaces by wiping with sponge and clean warm water

NOTICE: Avoid the use of abrasive cleaning, compounds, chloride based cleaners, or cleaners containing quaternary salts. Never use hydrochloric acid (muriatic acid) on stainless steel.

4. Surfaces can be wiped with a sanitizing solution after cleaning and rinsing. This solution must be approved for use on stainless steel food contact surfaces.



5. Clean heat guards with a window cleaner.
6. To help maintain the protective film coating on polished stainless steel, clean the exterior of the unit with a cleaner recommended for stainless steel surfaces. Spray the cleaning agent on a cloth and wipe with the grain of the stainless steel.

Always follow appropriate state or local health (hygiene) regulations regarding all applicable cleaning and sanitation requirements for foodservice equipment.

DANGER



To prevent **SERIOUS PERSONAL INJURY, DEATH, or PROPERTY DAMAGE:**

DO NOT steam clean, hose down or flood the interior or exterior with water or liquid solution of any kind. **DO NOT** use water jet to clean.

Failure to observe this precaution will void the warranty.

WARNING



To prevent **SERIOUS INJURY, DEATH, OR PROPERTY DAMAGE, ALWAYS** disconnect unit from power source before cleaning or servicing.

SANITATION

Food flavor and aroma are usually so closely related that it is difficult, if not impossible, to separate them. There is also an important, inseparable relationship between cleanliness and food flavor. Cleanliness, top operating efficiency, and appearance of equipment contribute considerably to savory, appetizing foods. Good equipment that is kept clean, works better and lasts longer.

Most food imparts its own particular aroma and many foods also absorb existing odors. Unfortunately, during this absorption there is not distinction between GOOD and BAD odors. The majority of objectionable flavors and odors troubling food service operations are caused by bacteria growth. Sourness, rancidity, mustiness, stale or other OFF flavors are usually the result of germ activity.

The easiest way to insure full, natural food flavor is through comprehensive cleanliness. This means good control of both visible soil (dirt) and invisible soil (germs). A thorough approach to sanitation will provide essential cleanliness. It will assure an attractive appearance of equipment, along with maximum efficiency and utility. More importantly, a good sanitation program provides one of the key elements in the prevention of food-borne illnesses.

A controlled holding environment for prepared foods is just one of the important factors involved in the prevention of food-borne illnesses. Temperature monitoring and control during receiving, storage, preparation, and the service of foods are of equal importance.

The most accurate method of measuring safe temperatures of both hot and cold foods is by internal product temperature. A quality thermometer is an effective tool for this purpose, and should be routinely used on all products that require holding at a specific temperature.

A comprehensive sanitation program should focus on the training of staff in basic sanitation procedures. This includes personal hygiene, proper handling of raw foods, cooking to a safe internal product temperature, and the routine monitoring of internal temperatures from receiving through service.

Most food-borne illnesses can be prevented through proper temperature control and a comprehensive program of sanitation. Both these factors are important to build quality service as the foundation of customer satisfaction. Safe food handling practices to prevent food-borne illness is of critical importance to the health and safety of your customers.

HACCP, an acronym for Hazard Analysis (at) Critical Control Points, is a quality control program of operating procedures to assure food integrity, quality, and safety. Taking steps necessary to augment food safety practices is both cost effective and relatively simple. While HACCP guidelines go far beyond the scope of this manual, additional information is available by contacting:

**CENTER FOR FOOD SAFETY AND APPLIED
NUTRITION FOOD AND DRUG ADMINISTRATION
1-888-SAFEFOOD
www.centerforfoodsafety.org**

INTERNAL FOOD PRODUCT TEMPERATURES		
HOT FOODS		
DANGER ZONE	40°F TO 140°F	(4°C TO 60°C)
CRITICAL ZONE	70°F TO 120°F	(21°C TO 49°C)
SAFE ZONE	140°F TO 165°F	(60°C TO 74°C)
COLD FOODS		
DANGER ZONE	ABOVE 40°F	(ABOVE 4°C)
SAFE ZONE	36°F TO 40°F	(2°C TO 4°C)
FROZEN FOODS		
DANGER ZONE	ABOVE 32°F	(ABOVE 0°C)
CRITICAL ZONE	0°F TO 32°F	(-18°C TO 0°C)
SAFE ZONE	0°F or below	(-18°C or below)

SERVICE

ITM2-48

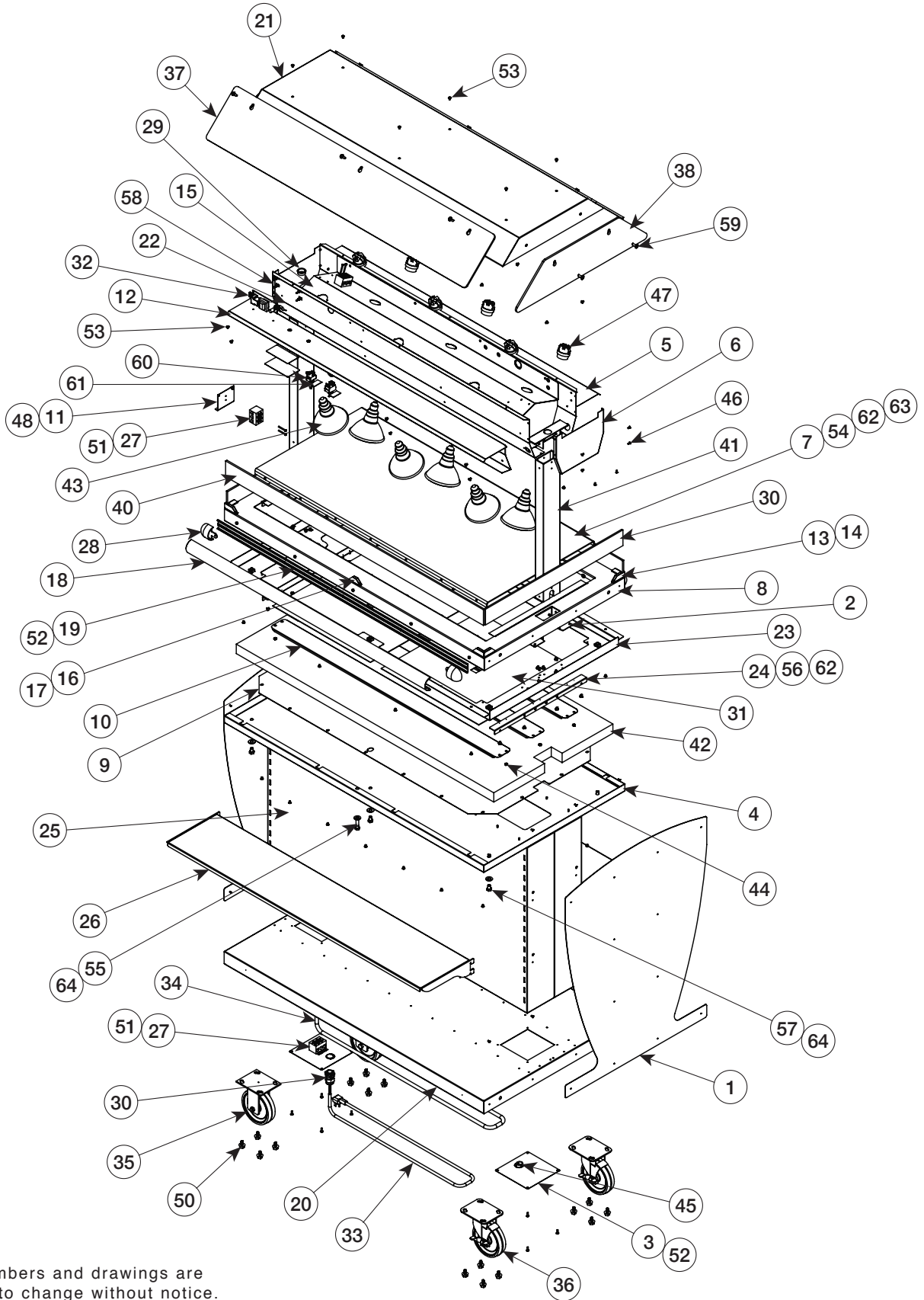

Part numbers and drawings are subject to change without notice.

SERVICE

ITM2-72

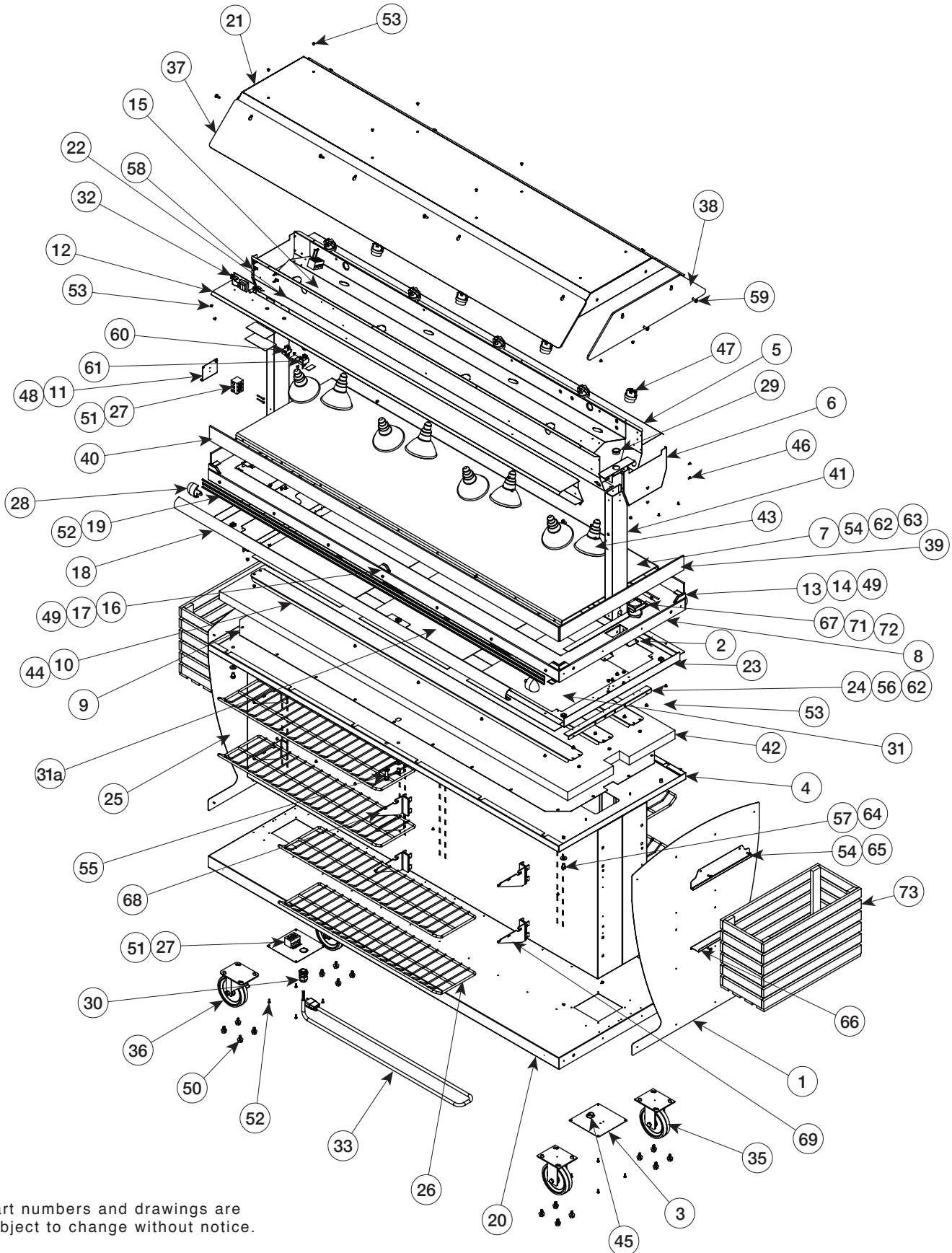

Part numbers and drawings are subject to change without notice.

SERVICE

SERVICE PARTS LIST

		MODEL >		ITM2-48		ITM2-72	
ITEM	DESCRIPTION	PART NO.	QTY	PART NO.	QTY		
1	SIDE PANEL SYSTEM	1006499	2	1009274	2		
2	HEAT PLATE HOLDER BRACKET	1006578	2	1006578	2		
3	CORD COVER PLATE	1006591	2	1006591	2		
4	BASE TOP	1006995	1	1008348	1		
5	INNER TOP SIDE	1007080	1	1008327	1		
6	INNER TOP LIGHT END	1007098	2	1007098	2		
7	HEAT PLATE	1007107	1	1008269	1		
8	HEAT PLATE HOLDER	1007108	1	1008256	1		
9	ACCESS PANEL	1007110	1	1008268	1		
10	HEAT PAD STIFFENER	1007503	3	1008270	3		
11	TERMINAL BRACKET HOLDER	1007507	1	1007507	1		
12	INNER TOP SIDE WITH CONTROLS	1008122	1	1008328	1		
13	HEAT GUARD BRACKET 1	1008177	4	1008177	4		
14	HEAT GUARD BRACKET 2	1008178	4	1008178	4		
15	INNER LIGHT PANEL	1008316	1	1008330	1		
16	HEAT GUARD, MIDDLE BRACKET 1	1008337	2	1008337	2		
17	HEAT GUARD, MIDDLE BRACKET 2	1008338	2	1008338	2		
18	BUMPER	1009067	2	1009068	2		
19	BUMPER TRACK	1009069	2	1009070	2		
20	BASE SUPPORT SPOT	5005235	1	5007460	1		
21	OUTER TOP SPOT	5005285	1	5007920	1		
22	INNER TOP SPOT	5005806	1	5007446	1		
23	HEAT PLATE HOLDER	5005843	1	5007413	1		
24	BRACKET STUD SPOT	5006314	2	5006314	2		
25	BASE STIFFENER SPOT	5006784	2	5008468	2		
26	SHELF SPOT, BLACK	5006851	2	—	—		
27	T-BLOCK	BK-3019	3	BK-3019	3		
28	BUMPER END CAP, BLACK	BM-27338	4	BM-27338	4		
29	1" HOLE BUSHING	BU-33619	3	BU-33619	3		
30	BUSHING STRAIN RELIEF 5.8-13.9mm	BU-34717	2	BU-34717	2		
31	HEAT PAD 18" x 18"	CB-34406	2	CB-34406	2		
31a	HEAT PAD 18" x 18"	—	—	CB-34407	1		
32	CONTROL BOARD, 120V	CC-34593	1	CC-34593	1		
33	CORDSET, 120V, 14/3 SJTOW, 15A-125V PLUG	CD-3232	1	CD-3397	1		
	CORDSET, 230V, 12/3 SJO, 20A-125V PLUG	CD-33490	1	CD-33490	1		
34	CORD 12/3 SJEOW-A	CD-3607	6 FEET	—	—		
35	CASTER, RIGID, 5"	CS-2025	2	CS-2025	2		
36	CASTER, SWIVEL WITH BRAKE, 5"	CS-2026	2	CS-2026	2		
37	LEXAN GUARD	GD-27330	2	GD-28075	2		
38	LEXAN GUARD, SIDE	GD-27331	2	GD-27331	2		
39	HEAT GUARD 1	GD-28024	2	GD-28024	2		
40	HEAT GUARD 2	GD-28025	2	GD-28026	2		
41	UPRIGHT SUPPORT HINGE	HG-27333	2	HG-27333	2		
42	22" x 47.5" FLUFF INSULATION - 2 PIECES	IN-22364	1	—	—		
	22" x 71-1/2" FLUFF INSULATION	—	—	IN-22364	1		

CONTINUED ON NEXT PAGE

SERVICE

SERVICE PARTS LIST

MODEL >		ITM2-48		ITM2-72	
ITEM	DESCRIPTION	PART NO.	QTY	PART NO.	QTY
43	LAMP, HALOGEN, 90W, 120V	LP-33592	6	LP-33592	8
	LAMP, HALOGEN, 175W, 230V	LP-37051	6	LP-33592	8
44	NUT, HEX #8-32	NU-2296	12	NU-2296	12
45	PLUG, 7/8" HOLE, NYLON, BLACK	PG-3559	1	PG-3559	1
46	RIVET, BLIND, #44, S/S	RI-2100	108	RI-2100	104
47	LAMP RECEPTACLE, 120V	RP-3952	6	RP-3952	8
48	10-32 x 1/4 PAN HD GROUND SCREW	SC-2190	1	SC-2190	1
49*	SCREW, 6-32 x 1/2, NC PHILLIPS, FLAT	SC-2239	12	SC-2239	12
50	5/16-18 x 5/8 SERR. HEX HD SCREW	SC-2351	16	SC-2351	16
51	SCREW, 6-32 x 1-1/4, NC PHILLIPS	SC-2365	6	SC-2365	6
52	8-32 x 1/2" PHIL SCREW	SC-2425	18	SC-2425	22
53	8-32 x 1/4" PHIL SCREW	SC-2459	84	SC-2459	96
54	SCREW, 10-32 x 1/2, NF PHIL TRUSS M/S, 18-8 S/S	SC-2661	14	SC-2661	26
55	3/8-16 x 1-1/2" HEX CAP	SC-22553	2	SC-22553	2
56	SCREW 10-32 x 1/4" PAN HEAD	SC-26791	26	SC-26791	26
57	3/8-16 x 1/2" HEX HEAD SCREW	SC-28060	6	SC-28060	6
58	SPACER, LOCK MOUNT PANEL	SP-33832	4	SP-33832	4
59	SHOULDER STUD LONG S/S	ST-2547	10	ST-2547	12
60	20A, 250V, DPST TOGGLE SWITCH	SW-3528	1	SW-3528	1
61	TOGGLE SWITCH 16(4) 250V T85	SW-33726	1	SW-33726	1
62	1" x 17" VHB TAPE 25 MIL	TA-24448	3 FEET	TA-24448	3 FEET
63	LOCK WASHER 1/4"	WS-2294	14	WS-2294	18
64	WASHER, FLAT	WS-23991	8	WS-23991	8
65	SIDE BASKET HOLDER 1	—	—	1006624	2
66	SIDE BASKET HOLDER 2	—	—	1007795	2
67	HOLDER, THERMOMETER	—	—	1009685	1
68	SHELF BRACKET SPOT LEFT	—	—	5008757	8
69	SHELF BRACKET SPOT RIGHT	—	—	5008758	8
70	BLOCK, 2 TERMINAL, PORCELAIN	—	—	BK-33546	2
71	SCREW, 10-32 x 3/8" HEX HD, S/S	—	—	SC-28434	2
72	SURFACE THERMOMETER 2"	—	—	TH-28401	1
73	WOOD BASKET, ADDITIONAL OPTION	—	—	BS-27896	2

*NOT SHOWN

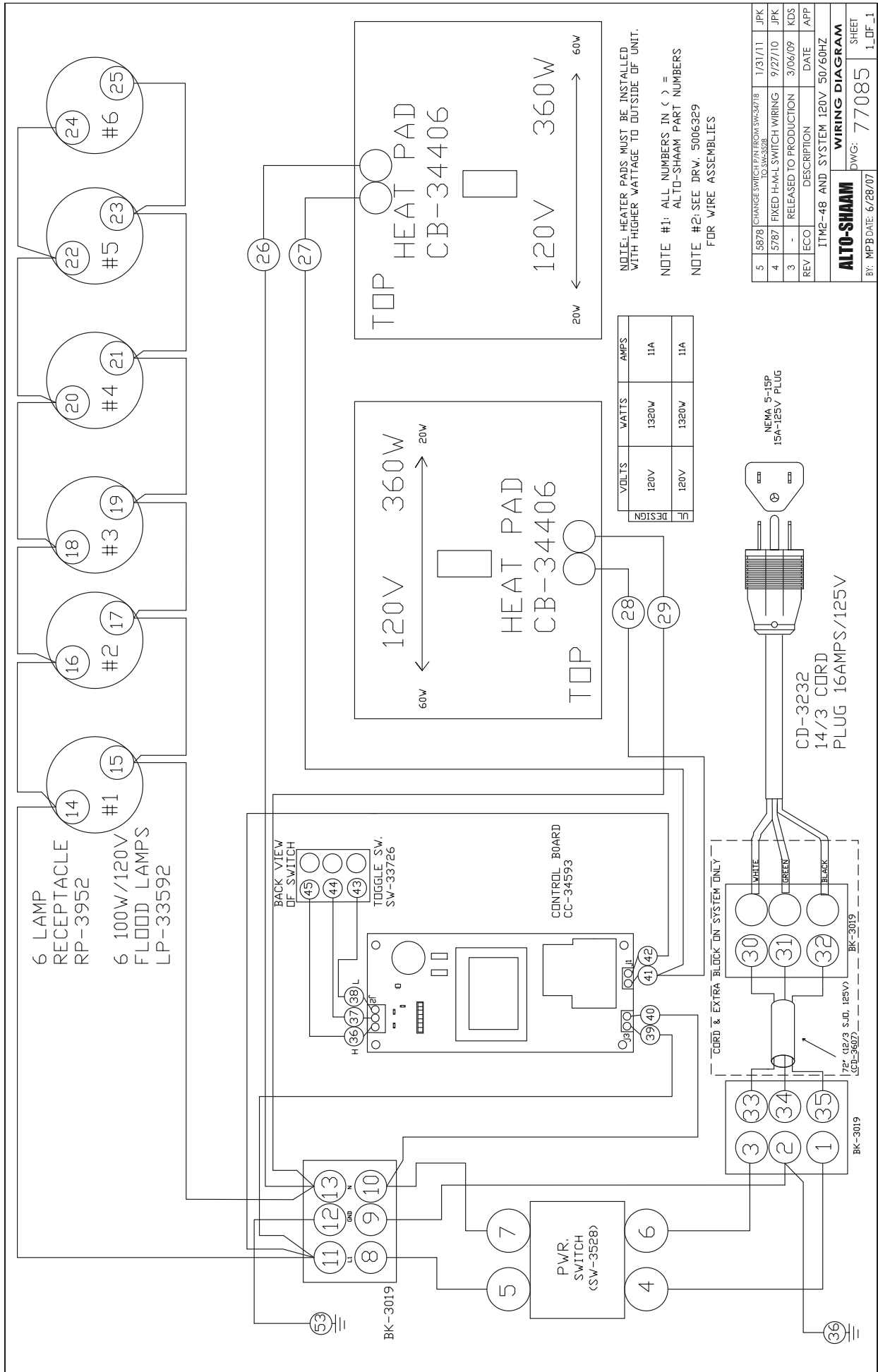

REV	ECO	DESCRIPTION	DATE	APP
5	5878	CHANGE SWITCH PIN FROM SW-54718 TO SW-3328	1/31/11	JPK
4	5787	FIXED H-M-L SWITCH WIRING	9/27/10	JPK
3	-	RELEASED TO PRODUCTION	3/06/09	KDS

ITM2-48 AND SYSTEM 120V 50/60HZ

AUTO-SHAAM

BY: MPB DATE: 6/28/07

DWG: 77085

WIRING DIAGRAM SHEET 1_OF_1

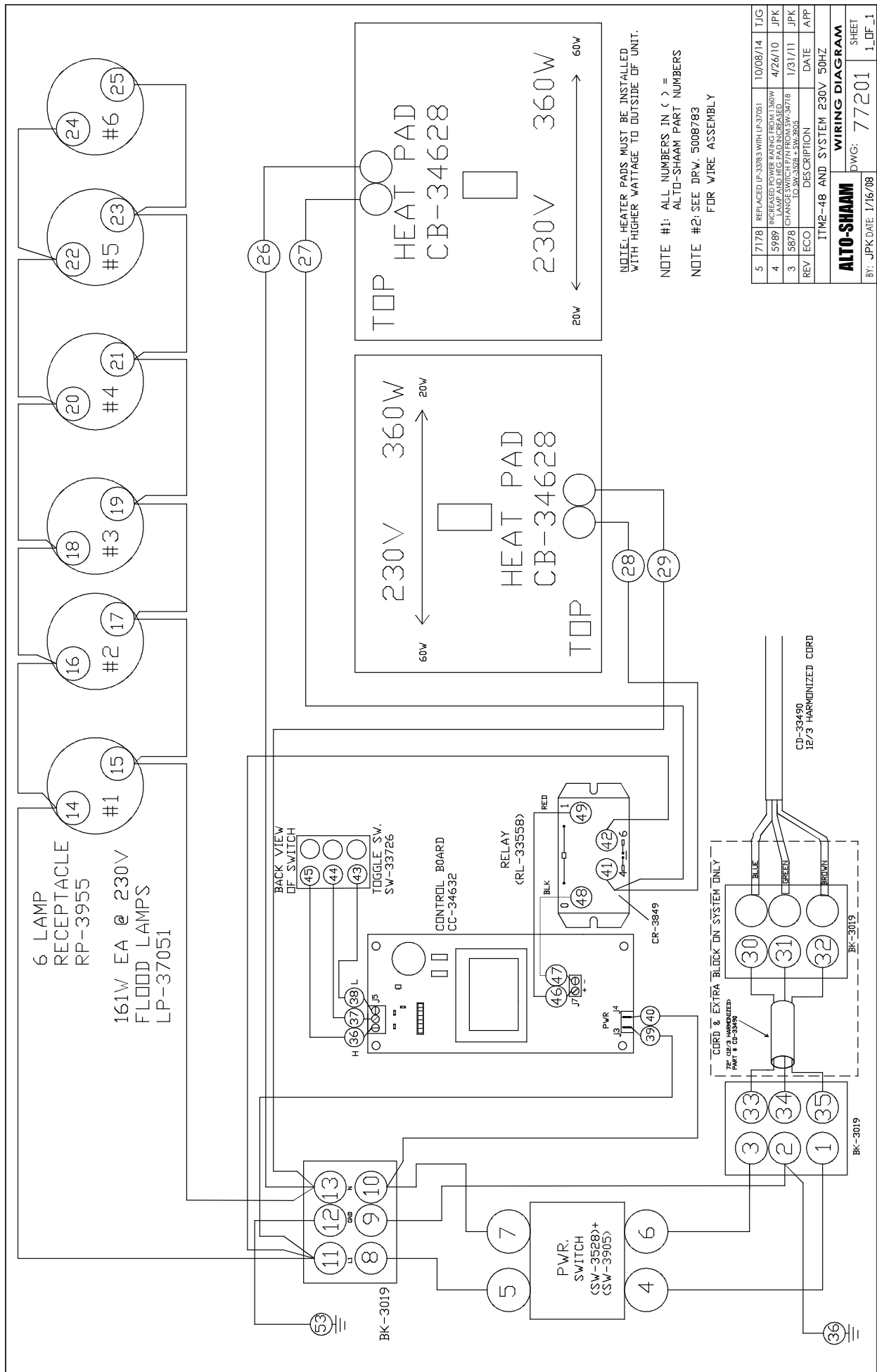

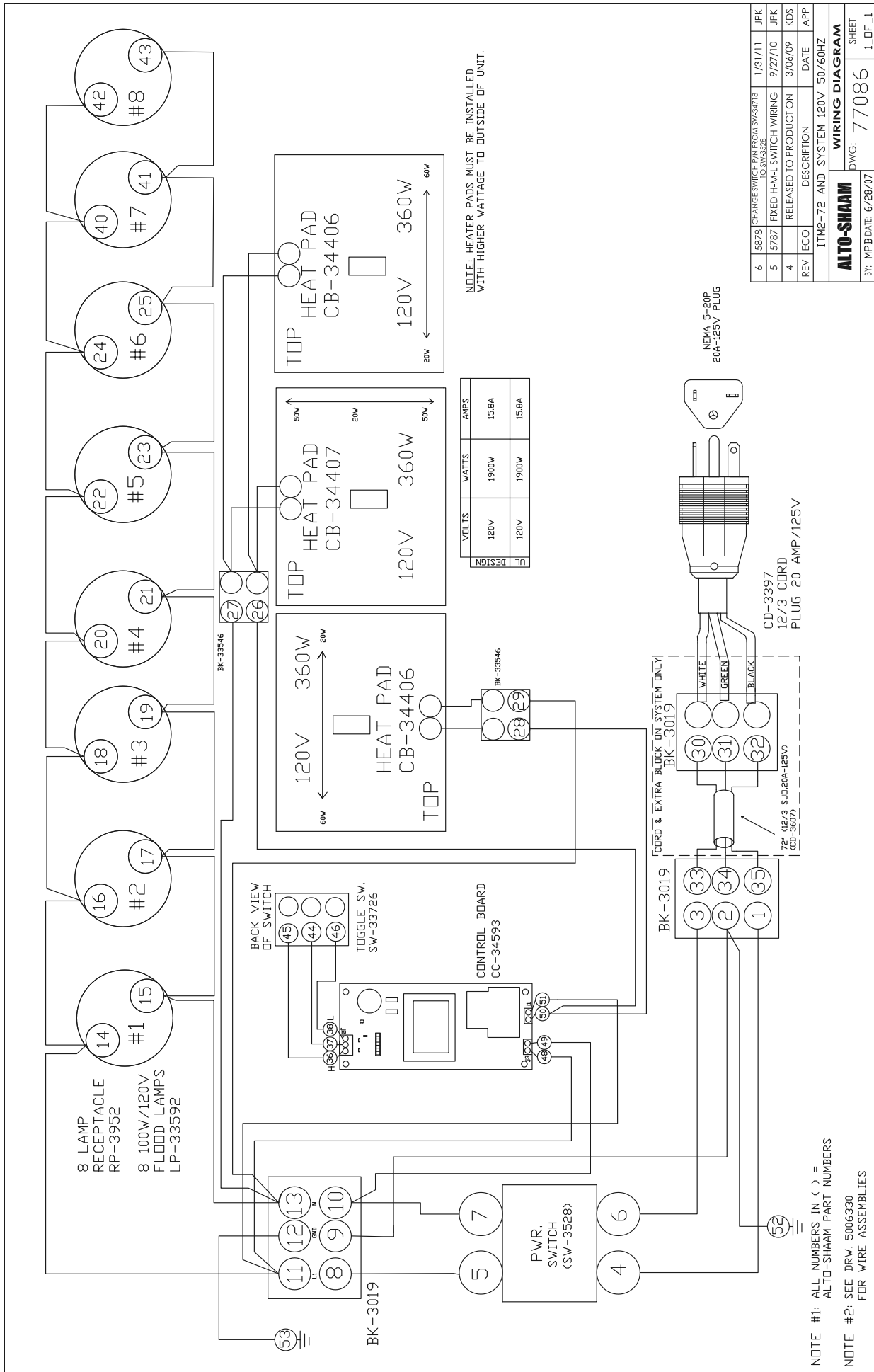

NOTE: HEATER PADS MUST BE INSTALLED WITH HIGHER WATTAGE TO OUTSIDE OF UNIT.

NOTE #1: ALL NUMBERS IN () = ALTO-SHAAM PART NUMBERS
 NOTE #2: SEE DRW. 5006330 FOR WIRE ASSEMBLIES

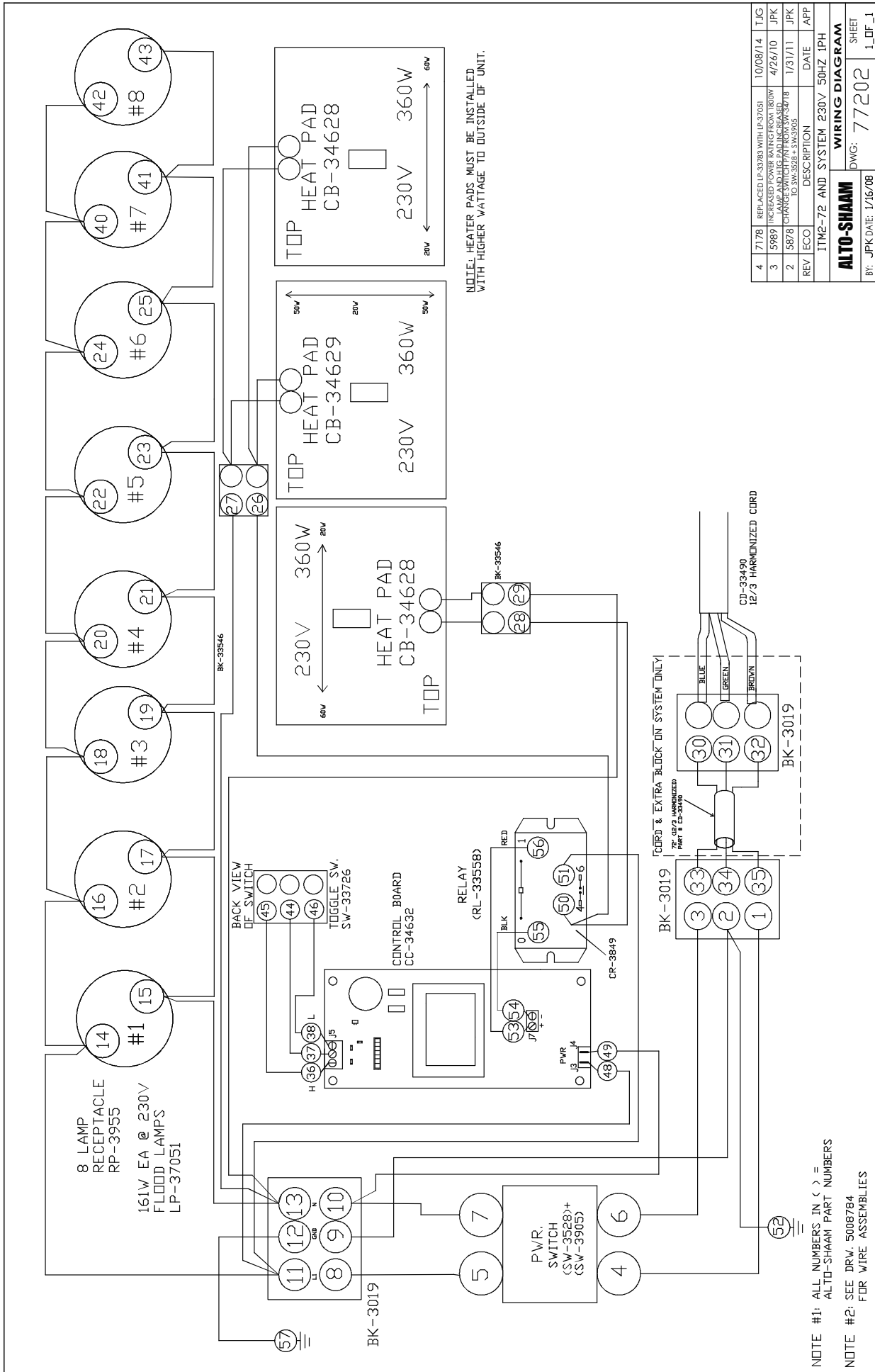

NOTE: HEATER PADS MUST BE INSTALLED WITH HIGHER VATTAGE TO OUTSIDE OF UNIT.

REV	ECO	DESCRIPTION	DATE	APP
4	7178	REPLACED LP-33783 WITH LP-37051	10/08/14	TJG
3	5989	THICK HEATER PADS TO 360W	4/26/10	JPK
2	5678	CHANGE SWITCH FROM SW-33718 TO SW-3358 + SW-3905	1/31/11	JPK

ITM2-72 AND SYSTEM 230V 50HZ 1PH	WIRING DIAGRAM
BY: JPK DATE: 1/16/08	DWG: 77202
	SHEET 1_DF_1

NOTE #1: ALL NUMBERS IN () = ALTO-SHAAM PART NUMBERS
 NOTE #2: SEE DRW. 5008784 FOR WIRE ASSEMBLIES

TRANSPORTATION DAMAGE and CLAIMS



All Alto-Shaam equipment is sold F.O.B. shipping point, and when accepted by the carrier, such shipments become the property of the consignee.

Should damage occur in shipment, do not put the appliance into service until the damage has been inspected by an authorized Alto-Shaam service provider.

Shipping damages are a matter between the carrier and the consignee. In such cases, the carrier is assumed to be responsible for the safe delivery of the merchandise, unless negligence can be established on the part of the shipper.

1. Make an immediate inspection while the equipment is still in the truck or immediately after it is moved to the receiving area. Do not wait until after the material is moved to a storage area.
2. Do not sign a delivery receipt or a freight bill until you have made a proper count and inspection of all merchandise received.
3. Note all damage to packages directly on the carrier's delivery receipt.
4. Make certain the driver signs this receipt. If he refuses to sign, make a notation of this refusal on the receipt.
5. If the driver refuses to allow inspection, write the following on the delivery receipt:
Driver refuses to allow inspection of containers for visible damage.
6. Telephone the carrier's office immediately upon finding damage, and request an inspection. Mail a written confirmation of the time, date, and the person called.
7. Save any packages and packing material for further inspection by the carrier.
8. Promptly file a written claim with the carrier and attach copies of all supporting paperwork.

We will continue our policy of assisting our customers in collecting claims which have been properly filed and actively pursued. We cannot, however, file any damage claims for you, assume the responsibility of any claims, or accept deductions in payment for such claims.

LIMITED WARRANTY

Alto-Shaam, Inc. warrants to the original purchaser only that any original part that is found to be defective in material or workmanship will, at Alto-Shaam's option, subject to provisions hereinafter stated, be replaced with a new or rebuilt part.

The original parts warranty period is as follows:

For the refrigeration compressor on Alto-Shaam Quickchillers™, five (5) years from the date of installation of appliance.

For the heating element on Halo Heat® cooking and holding ovens, as long as the original purchaser owns the oven. This excludes holding only equipment.

For all other original parts, one (1) year from the date of installation of appliance or fifteen (15) months from the shipping date, whichever occurs first.

The labor warranty period is one (1) year from the date of installation or fifteen (15) months from the shipping date, whichever occurs first.

Alto-Shaam will bear normal labor charges performed during standard business hours, excluding overtime, holiday rates or any additional fees.

To be valid, a warranty claim must be asserted during the applicable warranty period. This warranty is not transferable.

THIS WARRANTY DOES NOT APPLY TO:

1. Calibration.
2. Replacement of light bulbs, door gaskets, and/or the replacement of glass due to damage of any kind.
3. Equipment damage caused by accident, shipping, improper installation or alteration.
4. Equipment used under conditions of abuse, misuse, carelessness or abnormal conditions, including but not limited to, equipment subjected to harsh or inappropriate chemicals, including but not limited to, compounds containing chloride or quaternary salts, poor water quality, or equipment with missing or altered serial numbers.
5. Damage incurred as a direct result of poor water quality, inadequate maintenance of steam generators and/or surfaces affected by water quality. Water quality and required maintenance of steam generating equipment is the responsibility of the owner/operator.
6. Damage caused by use of any cleaning agent other than Alto-Shaam's Combitherm® Cleaner, including but not limited to damage due to chlorine or other harmful chemicals. **Use of Alto-Shaam's Combitherm® Cleaner on Combitherm® ovens is highly recommended.**
7. Any losses or damage resulting from malfunction, including loss of product, food product, revenue, or consequential or incidental damages of any kind.
8. Equipment modified in any manner from original model, substitution of parts other than factory authorized parts, removal of any parts including legs, or addition of any parts.

This warranty is exclusive and is in lieu of all other warranties, express or implied, including the implied warranties of merchantability and fitness for a particular purpose. In no event shall Alto-Shaam be liable for loss of use, loss of revenue or profit, or loss of product, or for any indirect, special, incidental, or consequential damages. No person except an officer of Alto-Shaam, Inc. is authorized to modify this warranty or to incur on behalf of Alto-Shaam any other obligation or liability in connection with Alto-Shaam equipment.



Effective November 1, 2012

RECORD THE MODEL AND SERIAL NUMBER OF THE APPLIANCE FOR EASY REFERENCE.

ALWAYS REFER TO BOTH MODEL AND SERIAL NUMBER IN ANY CONTACT WITH ALTO-SHAAM REGARDING THIS APPLIANCE.

Model: _____ Date Installed: _____
Voltage: _____ Purchased From: _____
Serial Number: _____

W164 N9221 Water Street • P.O. Box 450 • Menomonee Falls, Wisconsin 53052-0450 • U.S.A.

PHONE: 262.251.3800 • 800.558-8744 USA/CANADA FAX: 262.251.7067 • 800.329.8744 U.S.A. ONLY

www.alto-shaam.com

PRINTED IN U.S.A.