

Cooking & Holding Oven

Manual Control



Model:

500-TH-II

750-TH-II

1000-TH-II

1000-TH-II-SPLIT



1000-TH-II



1000-TH-II-Split



500-TH-II



750-TH-II



- **INSTALLATION**
- **OPERATION**
- **MAINTENANCE**



W164 N9221 Water Street • P.O. Box 450 • Menomonee Falls, Wisconsin 53052-0450 USA

PHONE: 262.251.3800 • 800.558.8744 USA/CANADA

FAX: 262.251.7067 • 800.329.8744 U.S.A. ONLY

www.alto-shaam.com

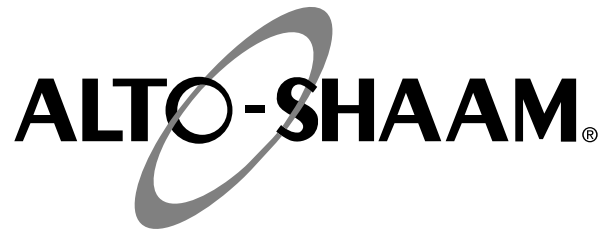

Delivery	1
Unpacking	1
Safety Procedures and Precautions	2

Installation

Installation Requirements	3
Clearance Requirements	3
Dimension Drawings, weights & capacities	4-7
Options and Accessories	8
Stacking Instructions	9
Leveling	10
Restraint Requirements - Mobile Equipment	10
Drip Tray Installation	11
Electrical Specifications	12

Operating Instructions

User Safety Information	13
Before Initial Use	13
Manual Control Operation	14
Cooking Oven Characteristics	14
General Holding Guidelines	15

Care and Cleaning

Cleaning and Preventative Maintenance	16
Protecting Stainless Steel Surfaces	16
Cleaning Agents	16
Cleaning Materials	16
Equipment Care	17
Clean Daily	17
Clean the Door Vents	17
Check Overall Condition of Oven	17

Sanitation

Sanitation/Food Safety	18
Internal Food Product Temperatures	18

Service

Thermostat/Indicator Light Sequence	19
Thermostat Calibration	19
Trouble Shooting	20
Exterior Service View	21
Exterior Service Parts List	22
Electrical Component Service View	23
Cable Heating Service Kits	23
Electrical Component Parts List	24

Wire Diagrams

500-TH-II, 120V	25
500-TH-II, 208-240V	26
500-TH-II, 230V	27
750-TH-II, 1000-TH-II, 120V	28
750-TH-II, 1000-TH-II, 208-240V	29
750-TH-II, 1000-TH-II, 230V	30

Warranty

Transportation Damage and Claims	Back Cover
Limited Warranty	Back Cover

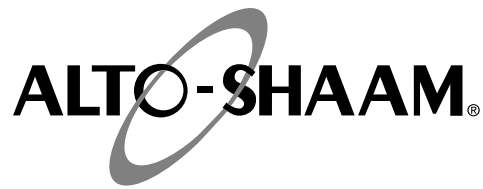

DELIVERY

This Alto-Shaam appliance has been thoroughly tested and inspected to ensure only the highest quality unit is provided. Upon receipt, check for any possible shipping damage and report it at once to the delivering carrier. See *Transportation Damage and Claims section located in this manual.*

This appliance, complete with unattached items and accessories, may have been delivered in one or more packages. Check to ensure that all standard items and options have been received with each model as ordered.

Save all the information and instructions packed with the appliance. Complete and return the warranty card to the factory as soon as possible to ensure prompt service in the event of a warranty parts and labor claim.

This manual must be read and understood by all people using or installing the equipment model. Contact the Alto-Shaam service department if you have any questions concerning installation, operation, or maintenance.

NOTE: All claims for warranty must include the full model number and serial number of the unit.

UNPACKING

1. Carefully remove the appliance from the carton or crate.

NOTE: Do not discard the carton and other packaging material until you have inspected the unit for hidden damage and tested it for proper operation.

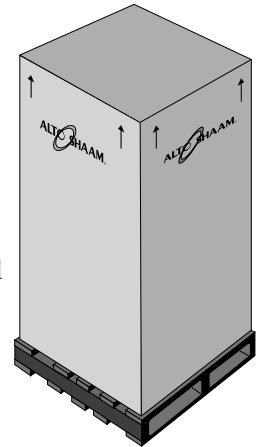

2. Read all instructions in this manual carefully before initiating the installation of this appliance.

DO NOT DISCARD THIS MANUAL.

This manual is considered to be part of the appliance and is to be provided to the owner or manager of the business or to the person responsible for training operators. *Additional manuals are available from the Alto-Shaam service department.*

3. Remove all protective plastic film, packaging materials, and accessories from the appliance before connecting electrical power. Store any accessories in a convenient place for future use.

SAFETY PROCEDURES AND PRECAUTIONS

Knowledge of proper procedures is essential to the safe operation of electrically and/or gas energized equipment. In accordance with generally accepted product safety labeling guidelines for potential hazards, the following signal words and symbols may be used throughout this manual.

DANGER	
	Used to indicate the presence of a hazard that WILL cause severe personal injury, death, or substantial property damage if the warning included with this symbol is ignored.

WARNING	
	Used to indicate the presence of a hazard that CAN cause personal injury, possible death, or major property damage if the warning included with this symbol is ignored.

CAUTION	
	Used to indicate the presence of a hazard that can or will cause minor or moderate personal injury or property damage if the warning included with this symbol is ignored.

CAUTION	
Used to indicate the presence of a hazard that can or will cause minor personal injury, property damage, or a potential unsafe practice if the warning included with this symbol is ignored.	

NOTE: Used to notify personnel of installation, operation, or maintenance information that is important but not hazard related.

1. This appliance is intended to cook, hold or process foods for the purpose of human consumption. No other use for this appliance is authorized or recommended.
2. This appliance is intended for use in commercial establishments where all operators are familiar with the purpose, limitations, and associated hazards of this appliance. Operating instructions and warnings must be read and understood by all operators and users.
3. Any troubleshooting guides, component views, and parts lists included in this manual are for general reference only and are intended for use by qualified technical personnel.
4. This manual should be considered a permanent part of this appliance. This manual and all supplied instructions, diagrams, schematics, parts lists, notices, and labels must remain with the appliance if the item is sold or moved to another location.

NOTE	
	For equipment delivered for use in any location regulated by the following directive: DO NOT DISPOSE OF ELECTRICAL OR ELECTRONIC EQUIPMENT WITH OTHER MUNICIPAL WASTE.

INSTALLATION

DANGER



IMPROPER INSTALLATION, ALTERATION, ADJUSTMENT, SERVICE, OR MAINTENANCE COULD RESULT IN SEVERE INJURY, DEATH, OR CAUSE PROPERTY DAMAGE.

READ THE INSTALLATION, OPERATING AND MAINTENANCE INSTRUCTIONS THOROUGHLY BEFORE INSTALLING OR SERVICING THIS EQUIPMENT.

CAUTION

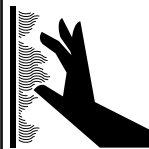

METAL PARTS OF THIS EQUIPMENT BECOME EXTREMELY HOT WHEN IN OPERATION. TO AVOID BURNS, ALWAYS USE HAND PROTECTION WHEN OPERATING THIS APPLIANCE.

CAUTION



TO PREVENT PERSONAL INJURY, USE CAUTION WHEN MOVING OR LEVELING THIS APPLIANCE.



DANGER



DO NOT store or use gasoline or other flammable vapors or liquids in the vicinity of this or any other appliance.

SITE INSTALLATION

The Alto-Shaam cook and hold oven must be installed in a location that will permit the oven to function for its intended purpose and to allow adequate clearance for ventilation, proper cleaning, and maintenance access.

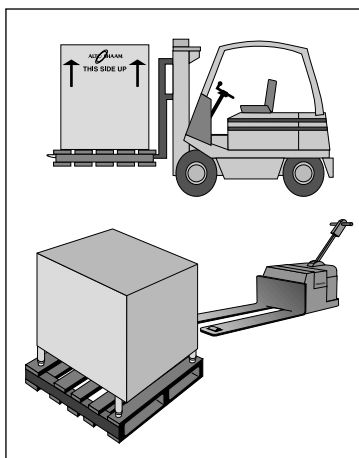

Emissions testing conducted by Underwriters Laboratories, Inc.® was found to be in compliance with the applicable requirements of NFPA96: 2004 Edition, Par. 4.1.1.2. U.L emissions sampling of grease laden vapor resulted in a total of 0.55 milligrams per cubic meter with no visible smoke and is considered representative of all oven models in the line. Based on these results, hood installation and/or outside venting should not be a requirement in most areas. Verify local codes for locations where more restrictive codes are applicable.

1. The oven must be installed on a stable and level surface.
2. **DO NOT** install this oven in any area where it may be affected by any adverse conditions such as steam, grease, dripping water, high temperatures, etc.
3. **DO NOT** store or use any flammable liquids or allow flammable vapors in the vicinity of this oven or any other appliance.
4. This appliance must be kept free and clear of any combustible materials.
5. This appliance must be kept free and clear of any obstructions blocking access for maintenance or service.

MINIMUM CLEARANCE REQUIREMENTS

	COMBUSTIBLE SURFACES	NON-COMBUSTIBLE SURFACES
BACK	3" (76mm)	3" (76mm)
LEFT SIDE	1" (25mm)	1" (25mm)
RIGHT SIDE	1" (25mm)	1" (25mm)
TOP	2" (51mm)	2" (51mm)

INSTALLATION

SITE INSTALLATION

500-TH-II

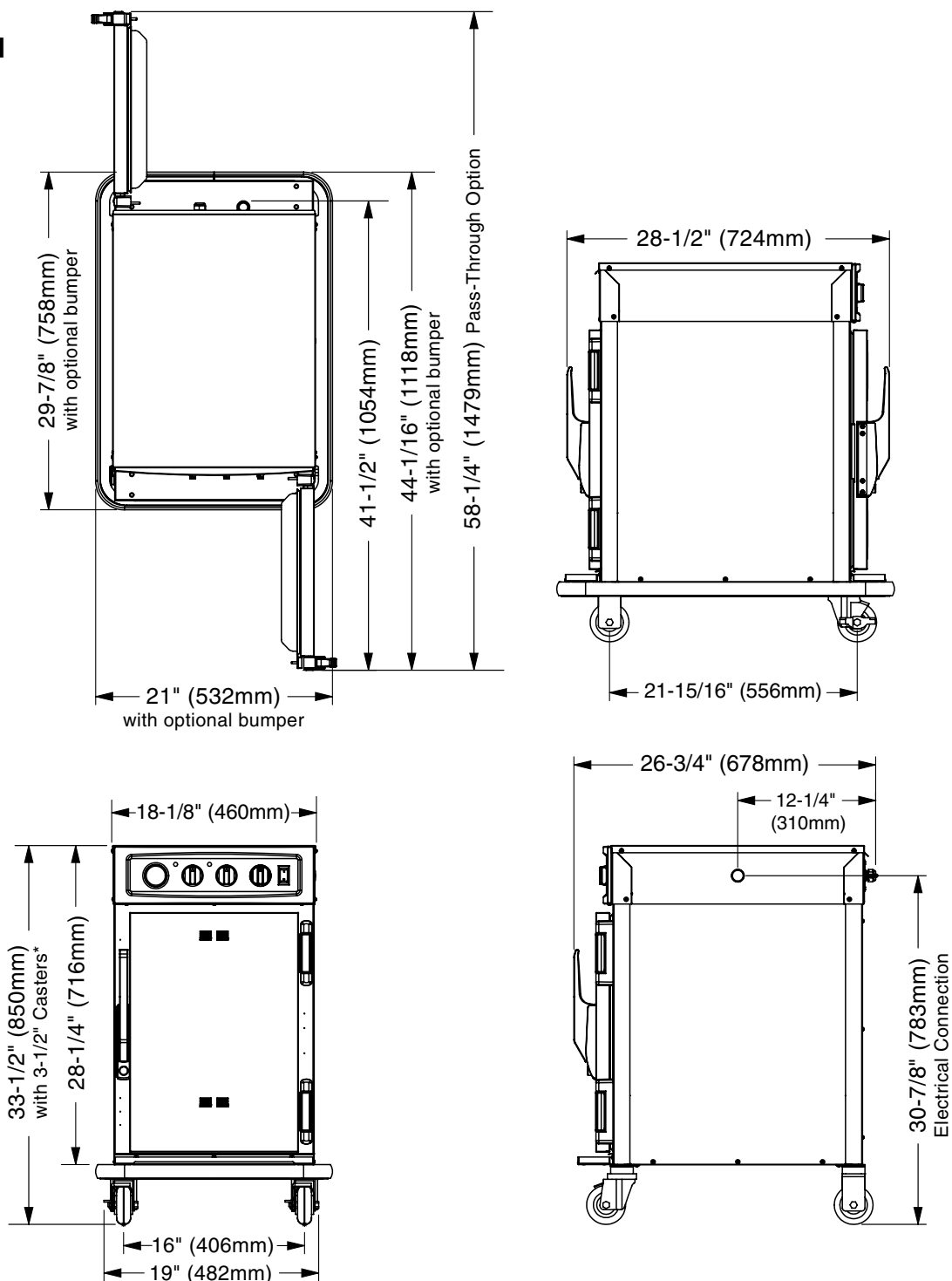

*31-13/16" (807mm) - with optional 2-1/2" casters

*35-3/16" (894mm) - with optional 5" casters

*34-7/16" (873mm) - with optional 6" legs

WEIGHT	PRODUCT/PAN CAPACITY (EACH COMPARTMENT)
<p>NET: 125 lb (57 kg) EST.</p> <p>SHIP: 150 lb (68 kg)</p>	<p>40 lb (18 kg) MAXIMUM</p> <p>VOLUME MAXIMUM: 30 QUARTS (38 LITERS)</p>

INSTALLATION

SITE INSTALLATION

750-TH-II

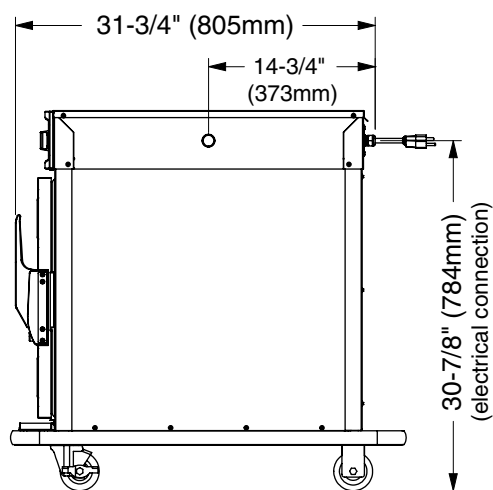
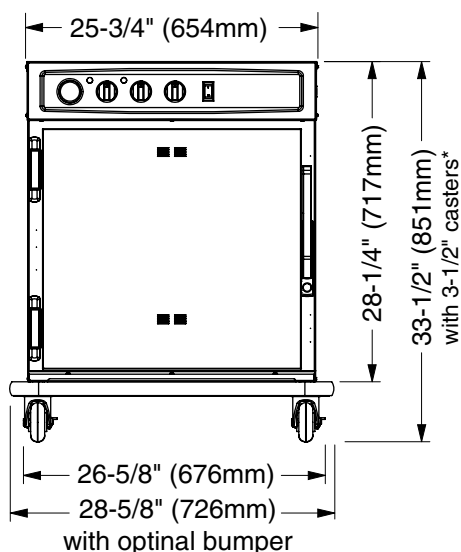
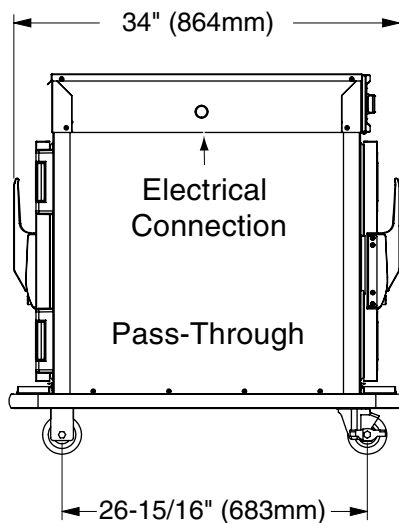
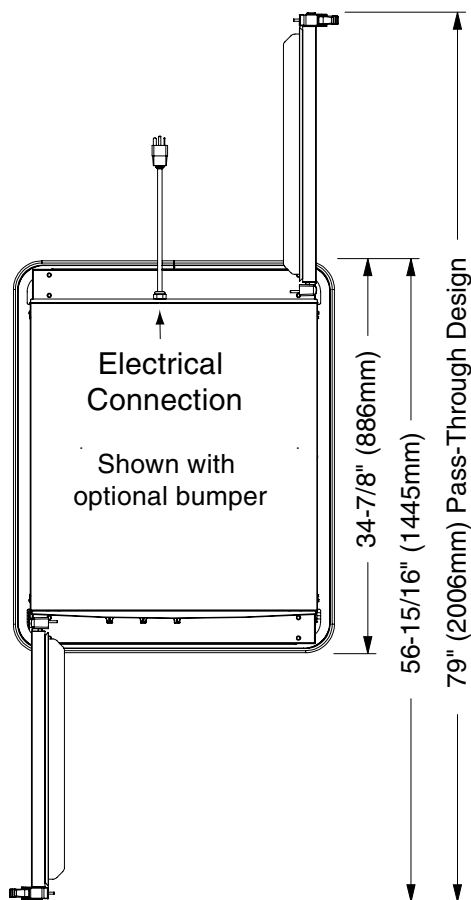

*31-13/16" (807mm) - with optional 2-1/2" casters

*35-1/4" (894mm) - with optional 5" casters

*34-7/16" (874mm) - with optional 6" legs

WEIGHT	PRODUCT/PAN CAPACITY (EACH COMPARTMENT)
NET: 186 lb (84 kg) SHIP: 225 lb (102 kg)	100 lbs (45 kg) MAXIMUM VOLUME MAXIMUM: 75 QUARTS (95 LITERS)

INSTALLATION

SITE INSTALLATION

1000-TH-II

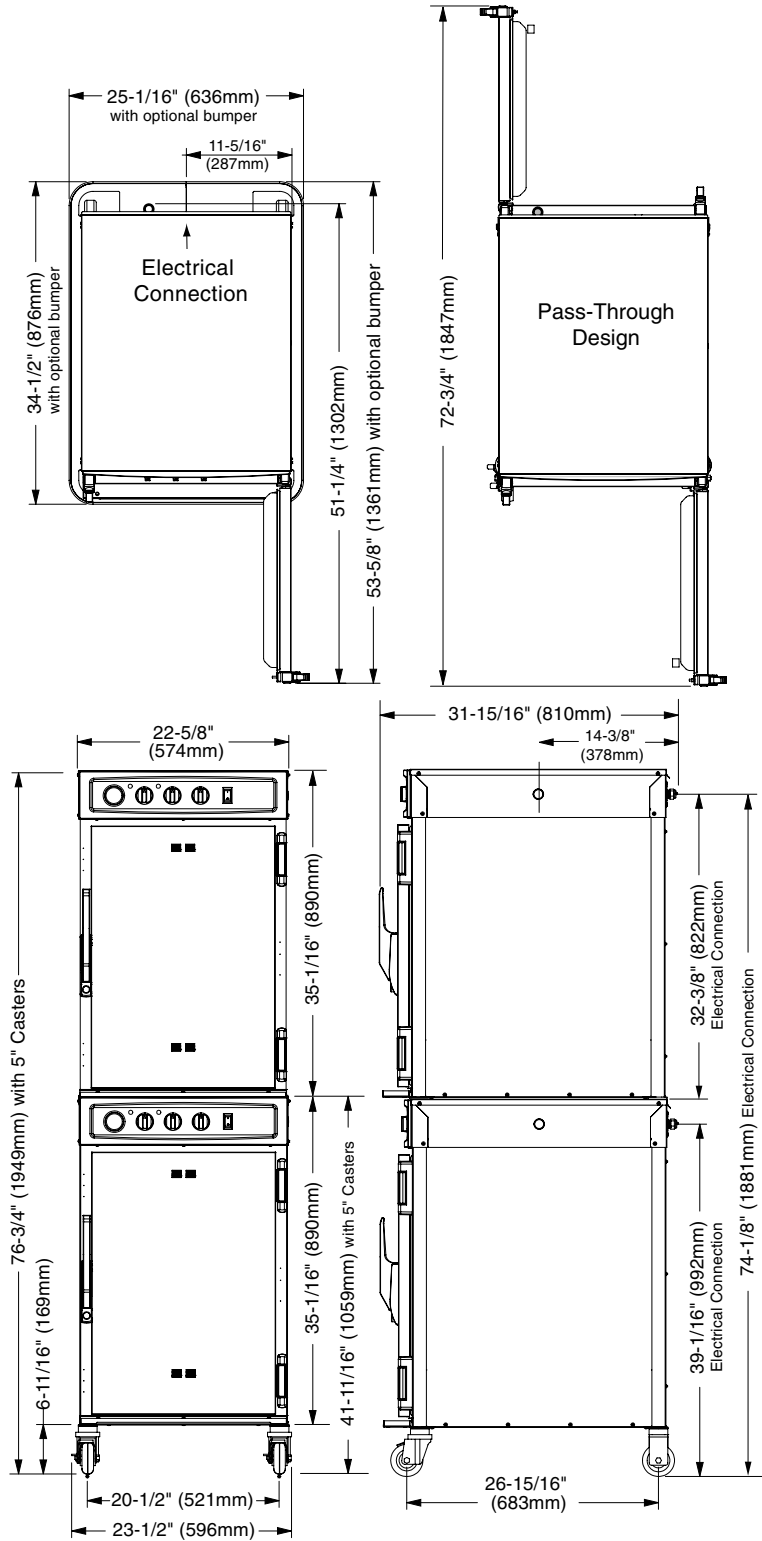

*75-3/8" (1915mm) with optional 3-1/2" (89mm) casters
 *76-1/16" (1932mm) approx. with optional 6" (152mm) legs

WEIGHT	PRODUCT/PAN CAPACITY (EACH COMPARTMENT)
NET: 450 lb (204 kg) EST. SHIP: 550 lb (249 kg)	120 lb (54 kg) MAXIMUM VOLUME MAXIMUM: 60 QUARTS (76 LITERS)

INSTALLATION

SITE INSTALLATION

1000-TH-II-SPLIT

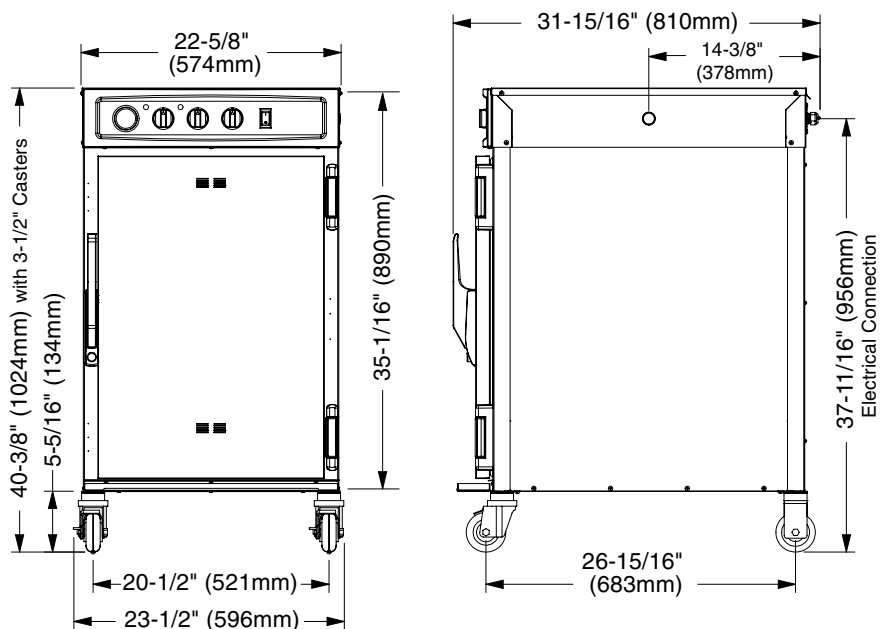
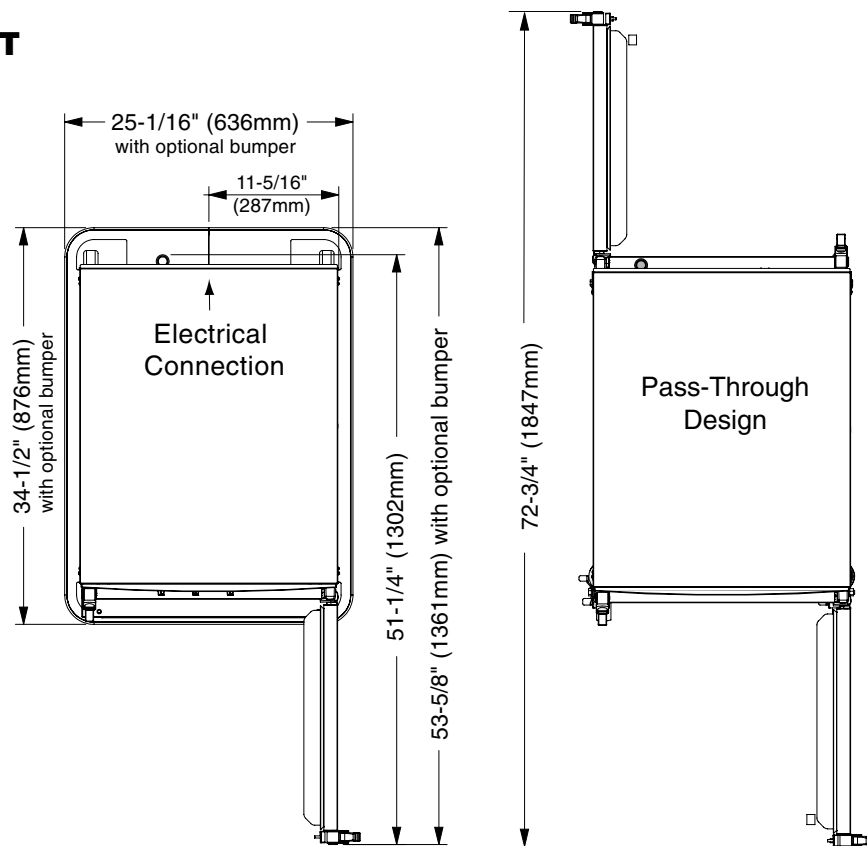

- *39-3/8" (999mm) with optional 2-1/2" (64mm) casters
- *41-11/16" (1059mm) with optional 5" (127mm) casters
- *41-1/16" (1042mm) approx. with optional 6" (152mm) legs

WEIGHT	PRODUCT\PAN CAPACITY
NET: 225 lb (102 kg) EST. SHIP: 275 lb (125 kg)	120 lb (54 kg) MAXIMUM VOLUME MAXIMUM: 60 QUARTS (76 LITERS)

INSTALLATION

OPTIONS AND ACCESSORIES	500-TH-II	750-TH-II	1000-TH-II	1000-TH-II-SPLIT
Bumper, Full Perimeter	5011161	5010371	5009767	5009767
Carving Holder, PRIME RIB STEAMSHIP (CAFETERIA) ROUND	HL-2635 4459	HL-2635 4459	HL-2635 4459	HL-2635 4459
Casters - 2 RIGID, 2 SWIVEL W/BRAKE 5" (127mm) 3-1/2" (89mm) 2-1/2" (64mm)	5004862 STANDARD 5008022	5004862 STANDARD 5008022	5004862 STANDARD —	STANDARD 5008017 5008022
Door with Window RIGHT-HAND LEFT-HAND	15855R 15857R	15433R 15732R	15879R 15881R	15879R 15881R
Door Lock with Key	LK-22567	LK-22567	LK-22567	LK-22567
Drip Pan STANDARD WITH DRAIN 1-7/16" (37mm) STANDARD WITH DRAIN 1-11/16" (43mm) STANDARD WITH DRAIN 1-7/8" (48mm) WITHOUT DRAIN, 1-7/16" (37mm) WITHOUT DRAIN, 1-7/8" (48mm) EXTRA DEEP, 4" (102mm)	14813 — — 11898 — —	— 14831 — — 11906 —	— — 5005616 — 11906 15929	— — 5005616 — 11906 15929
Legs, 6" (152mm), Stemmed (SET OF FOUR)	5011149	5011149	5011149	5011149
Pan Grid, Wire - 18" x 26" PAN INSERT	—	PN-2115	PN-2115	PN-2115
Security Panel w/ Key Lock	5006787	5004750	5005776	5005776
Shelf, Stainless Steel FLAT WIRE, REACH-IN FLAT WIRE, PASS-THROUGH RIB RACK	SH-2326 — —	SH-2324 SH-2327 SH-2743	SH-2325 SH-2346 SH-2773	SH-2325 SH-2346 SH-2773
Side Rack (230V ONLY)	AVAILABLE	AVAILABLE	AVAILABLE	AVAILABLE
Stacking Hardware	5004864	5004864	—	5004864

INSTALLATION

SITE INSTALLATION

STACKING INSTRUCTIONS

- 1) If the two appliances were shipped together from the factory, the top unit will have the casters already removed. A stacking kit will be included with the shipment.

If casters need to be removed: lay the unit on its back, and remove the set screw on each caster. Pull the casters out of the unit.

- 2) While appliance is laid on its back, insert one stacking post in each of the four corners of the upper unit. Secure the stacking posts using one screw and two flat washers that come with the stacking kit.

Note: The flange on the stacking posts must face the outside of the unit.

- 3) Remove the four top mounting screws from the lower unit. Place the upper appliance, which has the stacking posts installed, on top of the bottom unit. Center the top unit from front to back. Re-install the four screws through the flange of the four stacking posts.

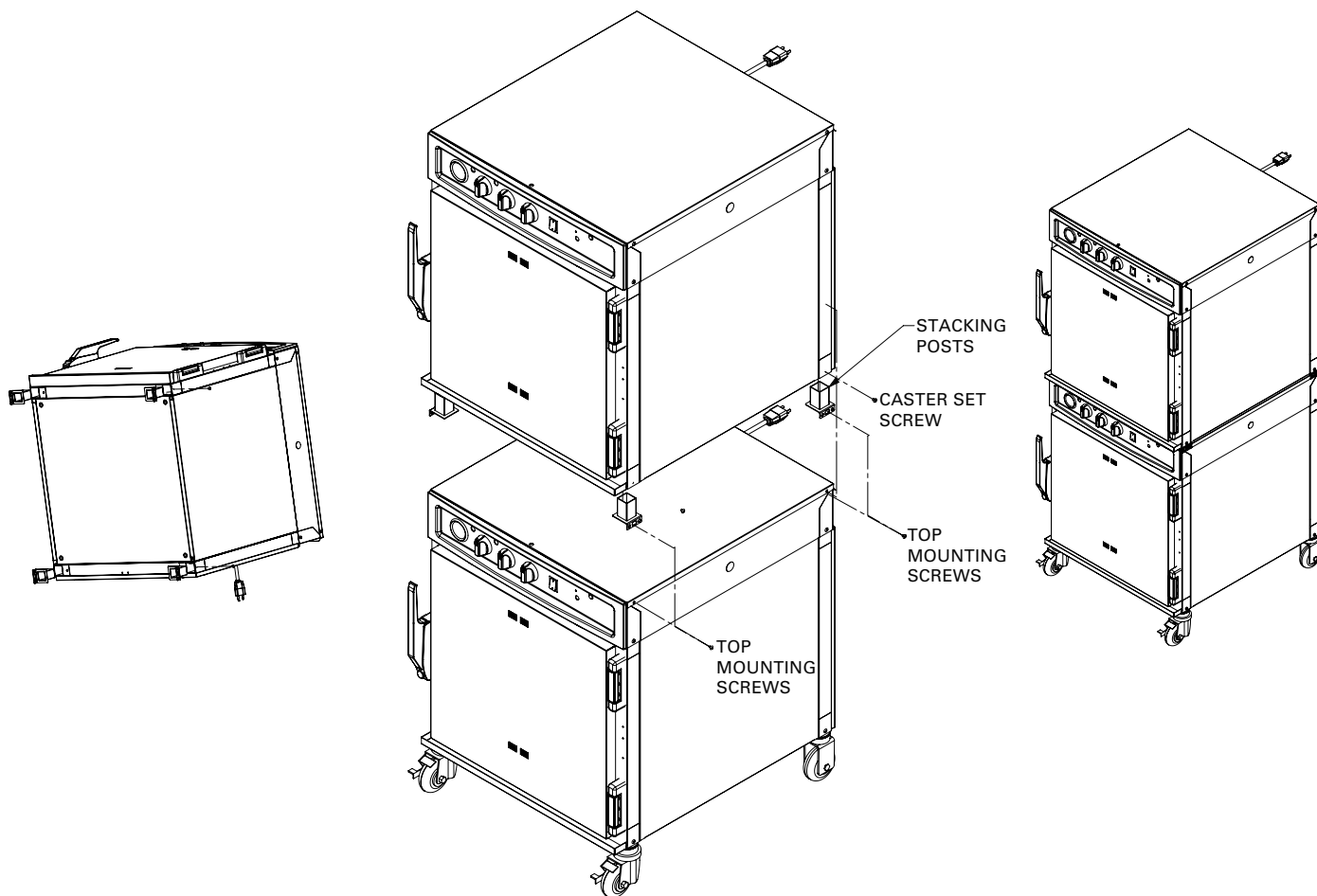

Stacking Configurations

1000-TH-II-Split with 1000-TH-II-Split or 1000-S
750-TH-II with 750-TH-II, 750-TH/III, 750-S, 767-SK or 767-SK/III
500-TH-II with 500-TH-II, 500-TH/III or 500-S

INSTALLATION

SITE INSTALLATION

A number of adjustments are associated with initial installation and start-up. It is important that these adjustments be conducted by a qualified service technician. Installation and start-up adjustments are the responsibility of the dealer or user. These adjustments include but are not limited to thermostat calibration, door adjustment, leveling, electrical hook-up and installation of optional casters or legs.

LEVELING

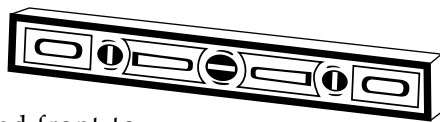

Level the oven from side-to-side and front-to-back with the use of a spirit level. For ovens installed with casters, it is important that the installation surface be level due to the probability of frequent oven repositioning.

We recommend checking the level of the oven periodically to make certain the floor has not shifted nor the oven moved.

NOTE: Failure to properly level this oven can cause improper function and will result in the uneven baking with products consisting of semi-liquid batter.

RESTRAINT REQUIREMENTS —MOBILE EQUIPMENT

 WARNING	
	RISK OF ELECTRIC SHOCK. Appliance must be secured to building structure.

Any appliance that is not furnished with a power supply cord but that includes a set of casters must be installed with a tether. Adequate means must be provided to limit the movement of this appliance without depending on or transmitting stress to the electrical conduit. The following requirements apply:

1. Maximum height of casters is 6" (152mm).
2. Two of the casters must of be the locking type.
3. Such mobile appliances or appliances on mobile stands must be installed with the use of a flexible connector secured to the building structure.

A mounting connector for a restraining device is located on the lower back flange of the appliance chassis or on an oven stand, approximately 18" (457mm) from the floor. A flexible connector is not supplied by nor is it available from the factory.

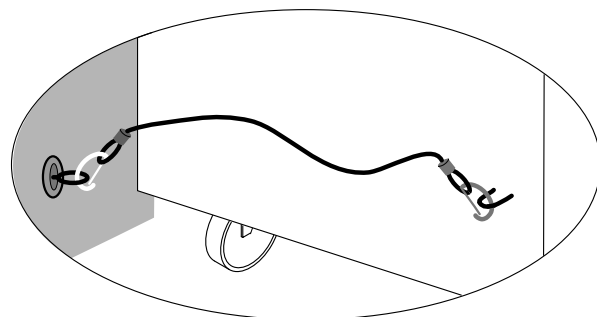

INSTALLATION

SITE INSTALLATION

DRIP TRAY INSTALLATION INSTRUCTIONS

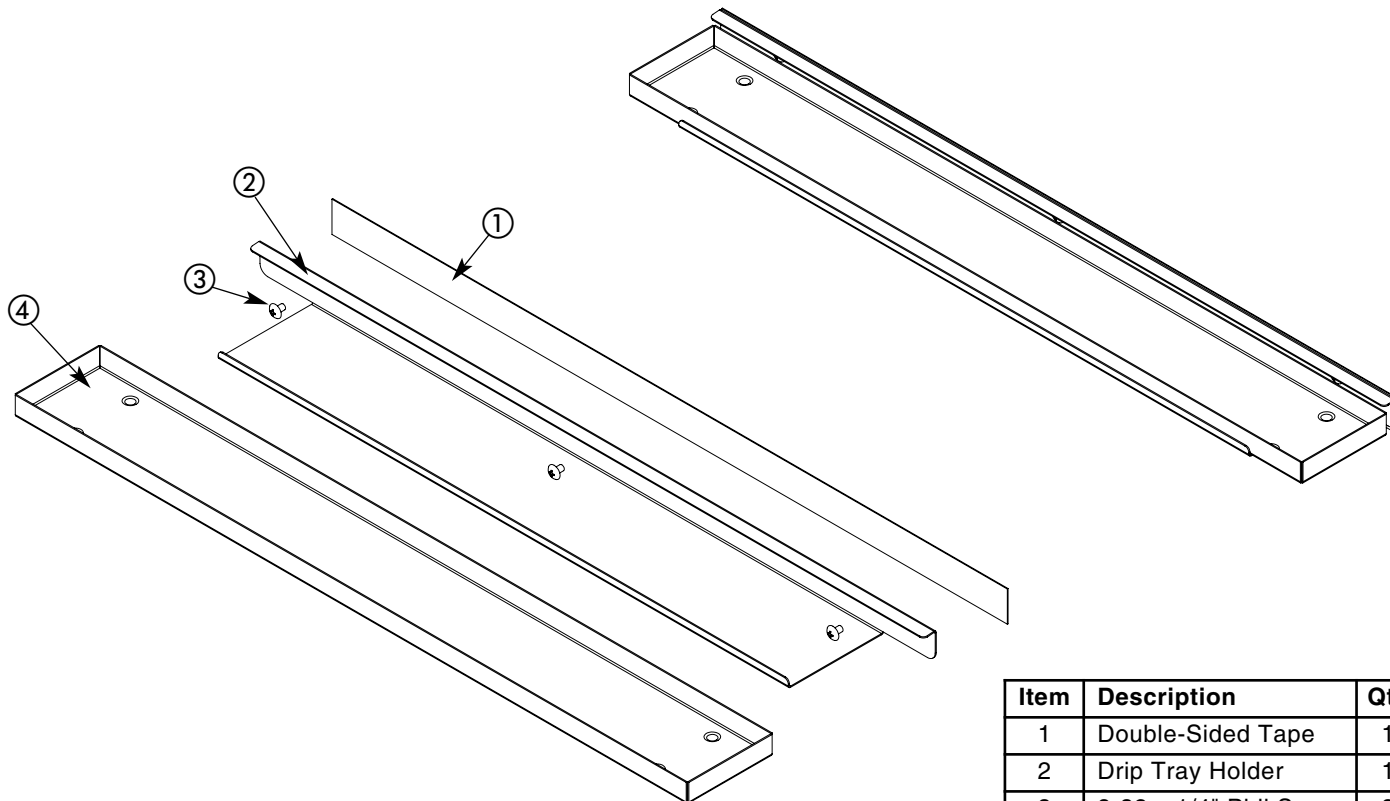

Item	Description	Qty
1	Double-Sided Tape	1
2	Drip Tray Holder	1
3	8-32 x 1/4" Phil Screw	3
4	Drip Tray	1

1. Poke holes through double-sided tape ① which is attached to the back of drip tray holder ②.
2. Remove backing on double-sided tape ①.
3. Put screws ③ through holes and attach drip tray holder ② to unit.
4. Optional - apply a line of food-grade silicone caulk along top edge of drip tray holder ② to seal.
5. Place drip tray ④ in drip tray holder ②.



WARNING

FAILURE TO PROPERLY INSTALL THE DRIP TRAY CAN OR WILL CAUSE MAJOR EQUIPMENT DAMAGE AND WILL RESULT IN A LEAKAGE HAZARD THAT CAN CAUSE PERSONAL INJURY.

INSTALLATION

ELECTRICAL CONNECTION

The appliance must be installed by a qualified service technician. The oven must be properly grounded in accordance with the National Electrical Code and applicable local codes.

Plug the unit into a properly grounded receptacle ONLY, positioning the unit so that the plug is easily accessible in case of an emergency. Arcing will occur when connecting or disconnecting the unit unless all controls are in the "OFF" position.

Proper receptacle or outlet configuration or permanent wiring for this unit must be installed by a licensed electrician in accordance with applicable local electrical codes.

750- and 1000-TH-II models at 208-240V are dual rated units with a conversion switch mounted under an access cover on the rear of the oven, near the power cord.

With the voltage conversion switch in the 200-208V (UPPER) position, the oven will function properly with a source voltage of between 200 and 208.

With the voltage conversion switch in the 220-240V (LOWER) position, the unit will function properly with a source voltage of between 220 and 240.

NOTE: ALL 208-240V units are shipped from the factory with the voltage conversion switch in the 220-240 position.

All 125V rated units will function properly with a source voltage of between 100 and 125, 60 Hz.



The 125V rated units are provided with a cord and plug [NEMA #5-20P]. Have a licensed electrician install the proper outlet configuration as required for the unit in accordance with applicable, local electrical codes. This will assure a safe and trouble-free installation.



230V: To prevent an electrical shock hazard between the appliance and other appliances or metal parts in close vicinity, an equalization-bonding stud is provided. An equalization bonding lead must be connected to this stud and the other appliances / metal parts to provide sufficient protection against potential difference. The terminal is marked with the following symbol.





NOTE: 230V appliances must be connected to an electrical circuit that is protected by an external GFCI outlet.

Ensure that the voltage conversion switch position and the available power source match.



ELECTRICAL - 500-TH-II						
VOLTAGE	PHASE	CYCLE/ HZ	AMPS	kW	CORD & PLUG	
120	1	60	16	1.9		NEMA 5-20P 20A - 125V PLUG
208-240 (AGCY)	1	60	12.5	3.0	NO CORD OR PLUG	
at 208	1	60	10.6	2.2		
at 240	1	60	12.2	2.9		
230	1	50	12	2.8		CEE 7/7 220-230V PLUG

ELECTRICAL - 750-TH-II						
VOLTAGE	PHASE	CYCLE/ HZ	AMPS	kW	CORD & PLUG	
120	1	60	14.2	1.7		NEMA 5-20P 20A - 125V PLUG
208-240 (AGCY)	1	60	14.4	3.0	NO CORD OR PLUG	
at 208	1	60	14.6	3.0		
at 240	1	60	11.2	2.7		
230	1	50	10.4	2.4		CEE 7/7 220-230V PLUG

ELECTRICAL - 1000-TH-II						
VOLTAGE	PHASE	CYCLE/ HZ	AMPS	kW	CORD & PLUG	
120	1	60	16.0	1.9		NEMA 5-20P 20A - 125V PLUG
208-240 (AGCY)	1	60	14.4	3.0	NO CORD OR PLUG	
at 208	1	60	14.4	3.0		
at 240	1	60	11.1	2.7		
230	1	50	10.4	2.4		CEE 7/7 220-230V PLUG

Wire diagrams are located inside the bonnet of the unit.

DANGER

To avoid electrical shock, this appliance MUST be adequately grounded in accordance with local electrical codes or, in the absence of local codes, with the current edition of the National Electrical Code ANSI/NFPA No. 70. In Canada, all electrical connections are to be made in accordance with CSA C22.1, Canadian Electrical Code Part 1 or local codes.

OPERATING INSTRUCTIONS

USER SAFETY INFORMATION

CAUTION



METAL PARTS OF THIS EQUIPMENT BECOME EXTREMELY HOT WHEN IN OPERATION. TO AVOID BURNS, ALWAYS USE HAND PROTECTION WHEN OPERATING THIS APPLIANCE.

The Alto-Shaam cook and hold oven is intended for use in commercial establishments by qualified operating personnel where all operators are familiar with the purpose, limitations, and associated hazards of this appliance. Operating instructions and warnings must be read and understood by all operators and users.

START-UP OPERATION

BEFORE INITIAL USE:

Interior oven surfaces must be heated to remove surface oils and the accompanying odor produced during the first use of the oven.

1. Wipe all wire shelves, side racks and the full oven interior with a clean, damp cloth. Install the oven side racks, oven shelves, and external drip tray. Shelves are installed with the curved edge toward the back of the oven. Insert the drip pan on the interior bottom surface of the oven.
2. Close the oven doors, press the power switch to the on position, and set the thermostat to 300°F (149°C).
3. Allow the oven to cycle for approximately 2 hours or until no odor is detected.

PREHEATING:

Always preheat the oven for a minimum of 20 minutes before cooking product. Follow the operating instructions indicated on the next page of this manual.

DANGER



AT NO TIME SHOULD THE INTERIOR OR EXTERIOR BE STEAM CLEANED, HOSED DOWN, OR FLOODED WITH WATER OR LIQUID SOLUTION OF ANY KIND. DO NOT USE WATER JET TO CLEAN.



SEVERE DAMAGE OR ELECTRICAL HAZARD COULD RESULT.

WARRANTY BECOMES VOID IF APPLIANCE IS FLOODED

DANGER



APPLIANCES WITH NO CORD PROVIDED BY FACTORY MUST BE EQUIPPED WITH A CORD OF SUFFICIENT LENGTH TO PERMIT THE APPLIANCE TO BE MOVED FOR CLEANING.



ELECTRICAL CONNECTIONS MUST BE MADE BY A QUALIFIED SERVICE TECHNICIAN IN ACCORDANCE WITH APPLICABLE ELECTRICAL CODES.



DANGER





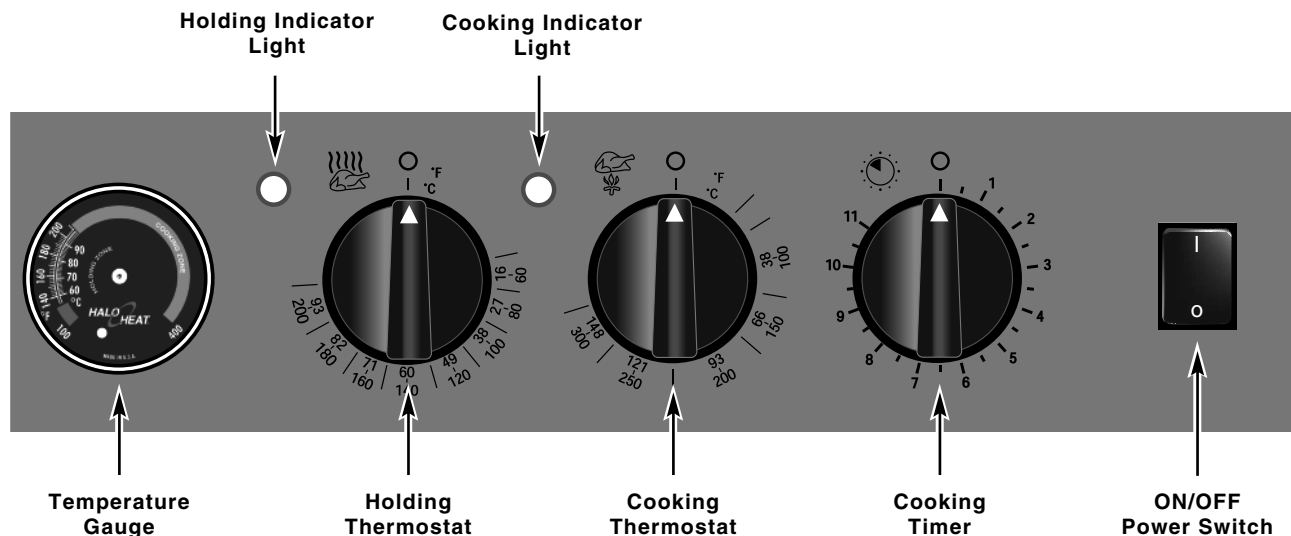

ENSURE POWER SOURCE MATCHES VOLTAGE STAMPED ON APPLIANCE NAMEPLATE.

OPERATING INSTRUCTIONS



MANUAL CONTROL OPERATION:

-  Turn oven POWER SWITCH 'ON'.
 — POWER SWITCH will illuminate and will remain lit as long as the Power Switch is in the 'ON' position.
-  Set the HOLD THERMOSTAT to the required holding temperature.
 — HOLDING INDICATOR LIGHT will illuminate as the Hold Thermostat calls for heat. This process will continue as long as the Power Switch and Hold Thermostat are 'ON'.
-  Set COOK THERMOSTAT to the required cooking temperature.
-  To preheat the oven, activate the Cook Thermostat by turning the COOKING TIMER clockwise.
 — COOKING INDICATOR LIGHT and HOLDING INDICATOR LIGHT will illuminate as the unit calls for heat. This process will continue until the COOKING TIMER cycles to the 'OFF' position.

COOKING OVEN CHARACTERISTICS:

The oven is equipped with a special, high-heat-density, heating cable. Through the Halo Heat concept, the heating cable is mounted against the walls of the cooking cavity to provide an evenly applied, thermostatically controlled, heat source. The design and operational characteristics of the oven eliminate the need for a moisture pan or a heat circulating fan. Through even heat application, the quality of a food product is maintained for many hours.



These instructions are basic operational guidelines only. For complete instructions, see A Guide to Low Temperature Cooking and Holding by HALO HEAT packed with the oven.

OPERATING INSTRUCTIONS

General Holding Guideline

Chefs, cooks and other specialized food service personnel employ varied methods of cooking. Proper holding temperatures for a specific food product must be based on the moisture content of the product, product density, volume, and proper serving temperatures. Safe holding temperatures must also be correlated with palatability in determining the length of holding time for a specific product.

Halo Heat maintains the maximum amount of product moisture content without the addition of water, water vapor, or steam. Maintaining maximum natural product moisture preserves the natural flavor of the product and provides a more genuine taste. In addition to product moisture retention, the gentle properties of Halo Heat maintain a consistent temperature throughout the cabinet without the necessity of a heat distribution fan, thereby preventing further moisture loss due to evaporation or dehydration.

When product is removed from a high temperature cooking environment for immediate transfer into equipment with the lower temperature required for hot food holding, condensation can form on the outside of the product and on the inside of plastic containers used in self-service applications. Allowing the product to release the initial steam and heat produced by high temperature cooking can alleviate this condition. To preserve the safety and quality of freshly cooked foods, however, a maximum of 1 to 2 minutes must be the only time period allowed for the initial heat to be released from the product.

Most Halo Heat Holding Equipment is provided with a thermostat control between 60° and 200°F (16° to 93°C). If the unit is equipped with vents, close the vents for moist holding and open the vents for crisp holding.

HOLDING TEMPERATURE RANGE		
MEAT	FAHRENHEIT	CELSIUS
BEEF ROAST — Rare	130°F	54°C
BEEF ROAST — Med/Well Done	155°F	68°C
BEEF BRISKET	160° — 175°F	71° — 79°C
CORN BEEF	160° — 175°F	71° — 79°C
PASTRAMI	160° — 175°F	71° — 79°C
PRIME RIB — Rare	130°F	54°C
STEAKS — Broiled/Fried	140° — 160°F	60° — 71°C
RIBS — Beef or Pork	160°F	71°C
VEAL	160° — 175°F	71° — 79°C
HAM	160° — 175°F	71° — 79°C
PORK	160° — 175°F	71° — 79°C
LAMB	160° — 175°F	71° — 79°C
POULTRY		
CHICKEN — Fried/Baked	160° — 175°F	71° — 79°C
DUCK	160° — 175°F	71° — 79°C
TURKEY	160° — 175°F	71° — 79°C
GENERAL	160° — 175°F	71° — 79°C
FISH/SEAFOOD		
FISH — Baked/Fried	160° — 175°F	71° — 79°C
LOBSTER	160° — 175°F	71° — 79°C
SHRIMP — Fried	160° — 175°F	71° — 79°C
BAKED GOODS		
BREADS/ROLLS	120° — 140°F	49° — 60°C
MISCELLANEOUS		
CASSEROLES	160° — 175°F	71° — 79°C
DOUGH — Proofing	80° — 100°F	27° — 38°C
EGGS — Fried	150° — 160°F	66° — 71°C
FROZEN ENTREES	160° — 175°F	71° — 79°C
HORS D'OEUVRES	160° — 180°F	71° — 82°C
PASTA	160° — 180°F	71° — 82°C
PIZZA	160° — 180°F	71° — 82°C
POTATOES	180°F	82°C
PLATED MEALS	140° — 165°F	60° — 74°C
SAUCES	140° — 200°F	60° — 93°C
SOUP	140° — 200°F	60° — 93°C
VEGETABLES	160° — 175°F	71° — 79°C
THE HOLDING TEMPERATURES LISTED ARE SUGGESTED GUIDELINES ONLY. ALL FOOD HOLDING SHOULD BE BASED ON INTERNAL PRODUCT TEMPERATURES. ALWAYS FOLLOW LOCAL HEALTH (HYGIENE) REGULATIONS FOR ALL INTERNAL TEMPERATURE REQUIREMENTS.		

CARE AND CLEANING

CLEANING AND PREVENTIVE MAINTENANCE

PROTECTING STAINLESS STEEL SURFACES



It is important to guard against corrosion in the care of stainless steel surfaces. Harsh, corrosive, or inappropriate chemicals can completely destroy the

protective surface layer of stainless steel. Abrasive pads, steel wool, or metal implements will abrade surfaces causing damage to this protective coating and will eventually result in areas of corrosion. Even water, particularly hard water that contains high to moderate concentrations of chloride, will cause oxidation and pitting that result in rust and corrosion. In addition, many acidic foods spilled and left to remain on metal surfaces are contributing factors that will corrode surfaces.

Proper cleaning agents, materials, and methods are vital to maintaining the appearance and life of this appliance. Spilled foods should be removed and the area wiped as soon as possible but at the very least, a minimum of once a day. Always thoroughly rinse surfaces after using a cleaning agent and wipe standing water as quickly as possible after rinsing.

CLEANING AGENTS

Use non-abrasive cleaning products designed for use on stainless steel surfaces. Cleaning agents must be chloride-free compounds and must not contain quaternary salts. Never use hydrochloric acid (muriatic acid) on stainless steel surfaces. Always use the proper cleaning agent at the manufacturer's recommended strength. Contact your local cleaning supplier for product recommendations.

CLEANING MATERIALS

The cleaning function can usually be accomplished with the proper cleaning agent and a soft, clean cloth. When more aggressive methods must be employed, use a non-abrasive scouring pad on difficult areas and make certain to scrub with the visible grain of surface metal to avoid surface scratches. Never use wire brushes, metal scouring pads, or scrapers to remove food residue.

 CAUTION	
 NO SCRAPERS	TO PROTECT STAINLESS STEEL SURFACES, COMPLETELY AVOID THE USE OF ABRASIVE CLEANING COMPOUNDS, CHLORIDE BASED CLEANERS, OR CLEANERS CONTAINING QUATERNARY SALTS. NEVER USE HYDROCHLORIC ACID (MURIATIC ACID) ON STAINLESS STEEL. NEVER USE WIRE BRUSHES, METAL SCOURING PADS OR SCRAPERS.
 NO WIRE BRUSHES	
 NO STEEL PADS	

CARE AND CLEANING

EQUIPMENT CARE

Under normal circumstances, this oven should provide you with long and trouble free service. There is no preventative maintenance required, however, the following Equipment Care Guide will maximize the potential life and trouble free operation of this oven.

The cleanliness and appearance of this equipment will contribute considerably to operating efficiency and savory, appetizing food. Good equipment that is kept clean works better and lasts longer.



CLEAN DAILY

1. Disconnect unit from power source, and let cool.
2. Remove all detachable items such as wire shelves, side racks, and drip pans. Clean these items separately.
3. Wipe the interior metal surfaces of the oven with a paper towel to remove loose food debris.
4. Clean the interior metal surfaces of the cabinet with a damp clean cloth or sponge and any good commercial detergent.



NOTE: Avoid the use of abrasive cleaning compounds, chloride based cleaners, or cleaners containing quaternary salts. Never use hydrochloric acid (muriatic acid) on stainless steel.

5. Spray heavily soiled areas with a water soluble degreaser and let stand for 10 minutes, then remove soil with a plastic scouring pad.
6. Wipe control panel, door vents, door handles, and door gaskets thoroughly since these areas harbor food debris.
7. Rinse surfaces by wiping with sponge and clean warm water.

8. Remove excess water with sponge and wipe dry with a clean cloth or air dry. Leave doors open until interior is completely dry. Replace side racks and shelves.
9. Wipe door gaskets and control panel dry with a clean, soft cloth.
10. Interior can be wiped with a sanitizing solution after cleaning and rinsing. This solution must be approved for use on stainless steel food contact surfaces.
11. To help maintain the protective film coating on polished stainless steel, clean the exterior of the cabinet with a cleaner recommended for stainless steel surfaces. Spray the cleaning agent on a clean cloth and wipe with the grain of the stainless steel.
12. Clean any glass with a window cleaner.

Always follow appropriate state or local health (hygiene) regulations regarding all applicable cleaning and sanitation requirements for equipment.

CLEAN THE DOOR VENTS

Door vents need to be inspected and cleaned as required.

CHECK OVERALL CONDITION OF OVEN ONCE A MONTH

Check the oven once a month for physical damage and loose screws. Correct any problems before they begin to interfere with the operation of the oven.

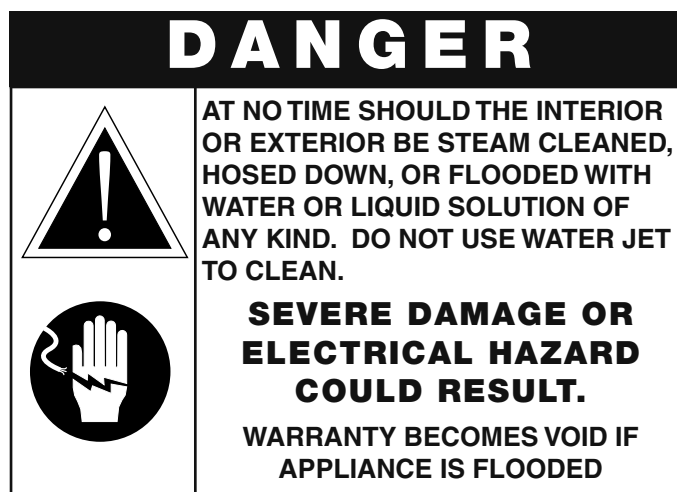
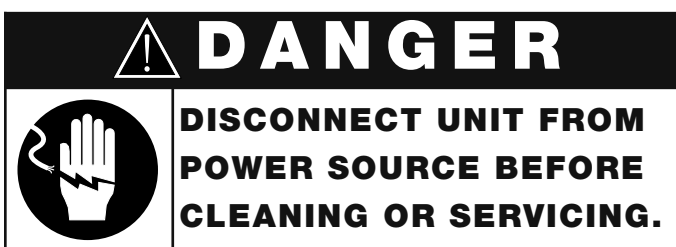

DO NOT USE OVEN IF CONTROLS ARE NOT PROPERLY FUNCTIONING

Refer to the Trouble Shooting Guide located in this manual or call an authorized service technician.

SANITATION

Food flavor and aroma are usually so closely related that it is difficult, if not impossible, to separate them. There is also an important, inseparable relationship between cleanliness and food flavor. Cleanliness, top operating efficiency, and appearance of equipment contribute considerably to savory, appetizing foods. Good equipment that is kept clean, works better and lasts longer.

Most food imparts its own particular aroma and many foods also absorb existing odors. Unfortunately, during this absorption there is no distinction between GOOD and BAD odors. The majority of objectionable flavors and odors troubling food service operations are caused by bacteria growth. Sourness, rancidity, mustiness, stale or other OFF flavors are usually the result of germ activity.

The easiest way to insure full, natural food flavor is through comprehensive cleanliness. This means good control of both visible soil (dirt) and invisible soil (germs). A thorough approach to sanitation will provide essential cleanliness. It will assure an attractive appearance of equipment, along with maximum efficiency and utility. More importantly, a good sanitation program provides one of the key elements in the prevention of food-borne illnesses.

A controlled holding environment for prepared foods is just one of the important factors involved in the prevention of food-borne illnesses. Temperature monitoring and control during receiving, storage, preparation, and the service of foods are of equal importance.

The most accurate method of measuring safe temperatures of both hot and cold foods is by internal product temperature. A quality thermometer is an effective tool for this purpose, and should be routinely used on all products that require holding at a specific temperature.

A comprehensive sanitation program should focus on the training of staff in basic sanitation procedures. This includes personal hygiene, proper handling of raw foods, cooking to a safe internal product temperature, and the routine monitoring of internal temperatures from receiving through service.

Most food-borne illnesses can be prevented through proper temperature control and a comprehensive program of sanitation. Both these factors are important to build quality service as the foundation of customer satisfaction. Safe food handling practices to prevent food-borne illness is of critical importance to the health and safety of your customers.

HACCP, an acronym for Hazard Analysis (at) Critical Control Points, is a quality control program of operating procedures to assure food integrity, quality, and safety. Taking steps necessary to augment food safety practices is both cost effective and relatively simple. While HACCP guidelines go far beyond the scope of this manual, additional information is available by contacting:

**CENTER FOR FOOD SAFETY AND APPLIED
NUTRITION FOOD AND DRUG ADMINISTRATION
1-888-SAFEFOOD**

INTERNAL FOOD PRODUCT TEMPERATURES		
HOT FOODS		
DANGER ZONE	40° TO 140°F	(4° TO 60°C)
CRITICAL ZONE	70° TO 120°F	(21° TO 49°C)
SAFE ZONE	140° TO 165°F	(60° TO 74°C)
COLD FOODS		
DANGER ZONE	ABOVE 40°F	(ABOVE 4°C)
SAFE ZONE	36° TO 40°F	(2° TO 4°C)
FROZEN FOODS		
DANGER ZONE	ABOVE 32°F	(ABOVE 0°C)
CRITICAL ZONE	0° TO 32°F	(-18° TO 0°C)
SAFE ZONE	0°F or below	(-18°C or below)

SERVICE

THERMOSTAT/INDICATOR LIGHT SEQUENCE

Whenever the thermostat is turned "ON", the indicator light will indicate the power ON/OFF condition of the heating cable, and consequently, the cycling of the cabinet as it maintains the dialed cavity temperature. If this light does not illuminate after normal start-up, the main power source, thermostat, and/or light must be checked. If the warming cabinet does not hold the temperature as dialed, the calibration of the thermostat must be checked. If the warming cabinet fails to heat or heats continuously with the thermostat "OFF", the thermostat must be initially checked for proper operation. If these items are checked and found to be in order, a continuity and resistance check of the heating cable should be made. *SEE CIRCUIT DIAGRAM.*

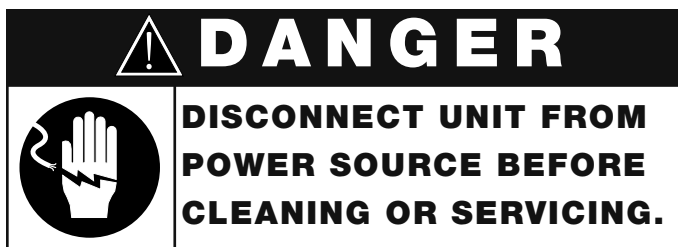

THERMOSTAT CALIBRATION

The thermostat is precision calibrated at the factory. Normally, no adjustment or recalibration is necessary unless the thermostat has been mishandled in transit, changed or abused while in service. A thermostat with a sensing bulb operates on hydraulic pressure, consequently, any bending of the bulb results in a change in its volume, and alters the accuracy of the thermostat calibration.

A thermostat should be checked or recalibrated by placing a quality, thermal indicator at the center of an empty holding cavity. **DO NOT CALIBRATE WITH ANY FOOD PRODUCT IN THE CABINET.** The thermostat should be set, and should be allowed to stabilize at that setting for a minimum of one hour. Following temperature stabilization, the center of the thermal swing of the air temperature within the cabinet should approximately coincide with the thermostat setting.

If calibration is necessary, the calibration screw should be adjusted with great care. The calibration screw of the thermostat is located in the thermostat dial shaft. With the shaft held stationary, a minute, clockwise motion of the calibration screw appreciably lowers the thermostat setting. A reverse, or counter-clockwise motion appreciably raises the thermostat setting. After achieving the desired cycling of the thermostat, the calibration screw must be sealed. Place a few drops of enamel sealant directly on the calibration screw.

(Red nail polish or equivalent is acceptable.)

SERVICE

TROUBLE SHOOTING CHECKLIST

TROUBLE	POSSIBLE CAUSE	REMEDY
Unit does not operate.	Insufficient electric power unit. Defective plug or cord. Power switch defective.	Check power source. Check and repair if necessary. Replace.
Cooking temperature not correct.	Cook thermostat out of calibration.	Calibrate.
Holding temperature not correct.	Hold thermostat out of calibration.	Calibrate.
Timer runs down, but oven will not go into HOLD.	Timer not de-energizing cook circuit.	Replace timer.
Cook thermostat erratic — will not hold calibration.	Cook thermostat.	Replace thermostat.
Hold thermostat erratic — will not hold calibration.	Hold thermostat.	Replace thermostat.
Oven goes from cooking temperature to cold.	Hold thermostat.	Replace hold thermostat.
Oven will not go into cook cycle when timer and cook thermostat are ON.	Timer or contactor.	With timer turned ON, line voltage should appear across terminal 2 and 3 of timer. If not, replace timer. If line voltage does appear across terminal 2 and 3 of timer, it should also appear across holding coil of contactor. If line voltage does appear across holding coil, and it won't close its contacts, replace contactor.
It takes too long to cook. (Temperature O.K.)	Heating element open, resulting in low wattage.	Replace element.
Cannot control temperature but thermostats check O.K.	Heating element grounded.	Replace element.

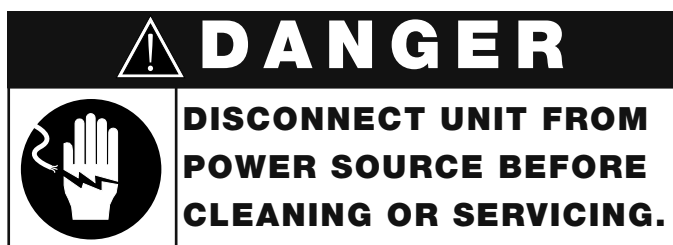

SERVICE

SERVICE VIEW

EXTERIOR VIEW - 750-TH-II SHOWN (A)

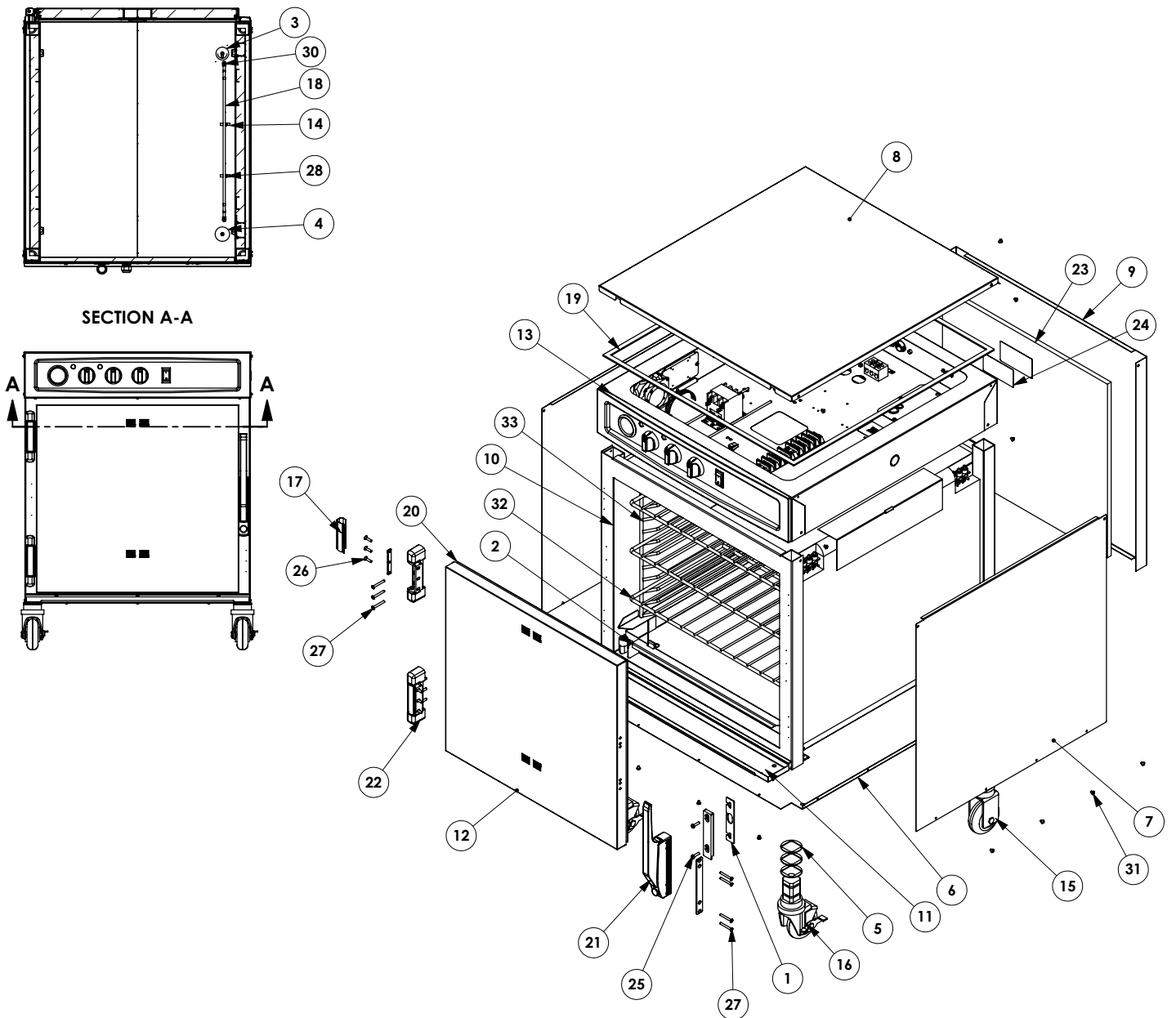

Part numbers and drawings are subject to change without notice.

SERVICE

SERVICE VIEW - EXTERIOR

EXTERIOR PARTS LIST **(A)**

MODEL >		500-TH-II		750-TH-II		1000-TH-II 1000-TH-II-SPLIT	
ITEM	DESCRIPTION	PART NO.	QTY	PART NO.	QTY	PART NO.	QTY/EA
1	SHIM, HANDLE	13947	1	13947	1	13947	1
2	DRIP PAN WELD	14813	1	14831	1	5005616	1
3	NON-SENSOR COVER	1005886	1	1005886	1	1005886	1
4	NON-PRODUCT PROBE SEAL	1006871	1	1006871	1	1006871	1
5	CASTER SPACER	1007145	12	1007145	12	1007145	12
6	BOTTOM PANEL	1010774	1	1010394	1	1009941	1
7	PANEL, SIDE, STAINLESS STEEL	1010799	2	1010395	2	1010575	2
8	BONNET, TOP COVER	1010780	1	1010401	1	1009951	1
9	BACK PANEL	1010801	1	1010957	1	1010574	1
10	ELEMENT KIT						
	120V	4879	1	4879	1	4879	1
	208-240V	4879	1	4881	1	4881	1
	230V	4881	1	4881	1	4881	1
11	DRIP TRAY KIT	5010736	1	5010391	1	5009716	1
12	DOOR ASSEMBLY, RH	5010828	1	5010946	1	5010081	1
	DOOR ASSEMBLY, LH	5010824	1	5010947	1	5010071	1
13	BONNET ASSEMBLY, SPOT	5010731	1	5009854	1	5009188	1
14	BLOCK CAP HOLD DOWN	BK-33844	2	BK-33844	2	BK-33844	2
15	CASTER, 3-1/2" RIGID	CS-25674	2	CS-25674	2	—	—
	CASTER, 5" RIGID	—	—	—	—	CS-24874	2
16	CASTER, 3-1/2" SWIVEL W/ BRAKE	CS-25675	2	CS-25675	2	—	—
	CASTER, 5" SWIVEL W/ BRAKE	—	—	—	—	CS-24875	2
17	COVER, HINGE	CV-22171	2	CV-22171	2	CV-22171	2
18	GUARD, CAPILLARY	GD-2450	1	GD-2450	1	GD-2450	1
19	GASKET, BONNET	GS-23622	1	GS-23622	1	GS-23622	1
20	GASKET, DOOR	GS-22950	1	GS-22951	1	GS-22952	1
21	HANDLE, OFFSET MAG. LATCH	HD-27080	1	HD-27080	1	HD-27080	1
22	HINGE	HG-22338	1	HG-22338	1	HG-22338	1
23	INSULATION	IN-2003	1	IN-2003	1	IN-2003	1
24	RATING TAG	LA-26348	2	LA-26348	2	LA-26348	2
25	SCREW, 3/4" PAN HD	SC-2071	2	SC-2071	2	SC-2071	2
26	SCREW, 10-32 X 3/4, NF PHIL	SC-2072	6	SC-2072	6	SC-2072	6
27	SCREW, 10-32 X 1-1/2, NF, PHIL	SC-2073	10	SC-2073	10	SC-2073	10
28	SCREW, 8-32 X 5/8" PAN HD	SC-2077	2	SC-2077	2	SC-2077	2
29*	SCREW, 1/4-20 X 1/2, NC SLOT RND	SC-2332	4	SC-2332	4	SC-2332	4
30	SCREW, 8-32 X 1/2 PHIL	SC-2425	2	SC-2425	2	SC-2425	2
31	SCREW, 8-32 X 1/4" PHIL	SC-2459	28	SC-2459	30	SC-2459	30
32	SHELF, STAINLESS STEEL	SH-2326	3	SH-2324	3	SH-2325	3
33	SIDE RACK, CHROME	SR-28403	2	SR-28405	2	SR-2266	2

*NOT SHOWN

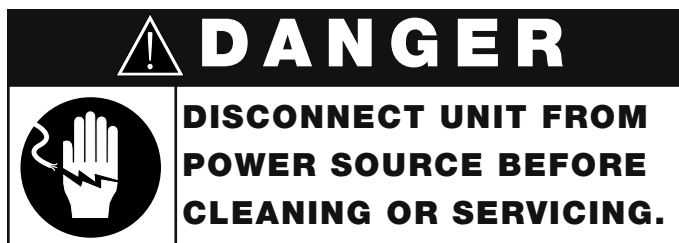

SERVICE

ELECTRONIC COMPONENTS (B)

208-240V SHOWN

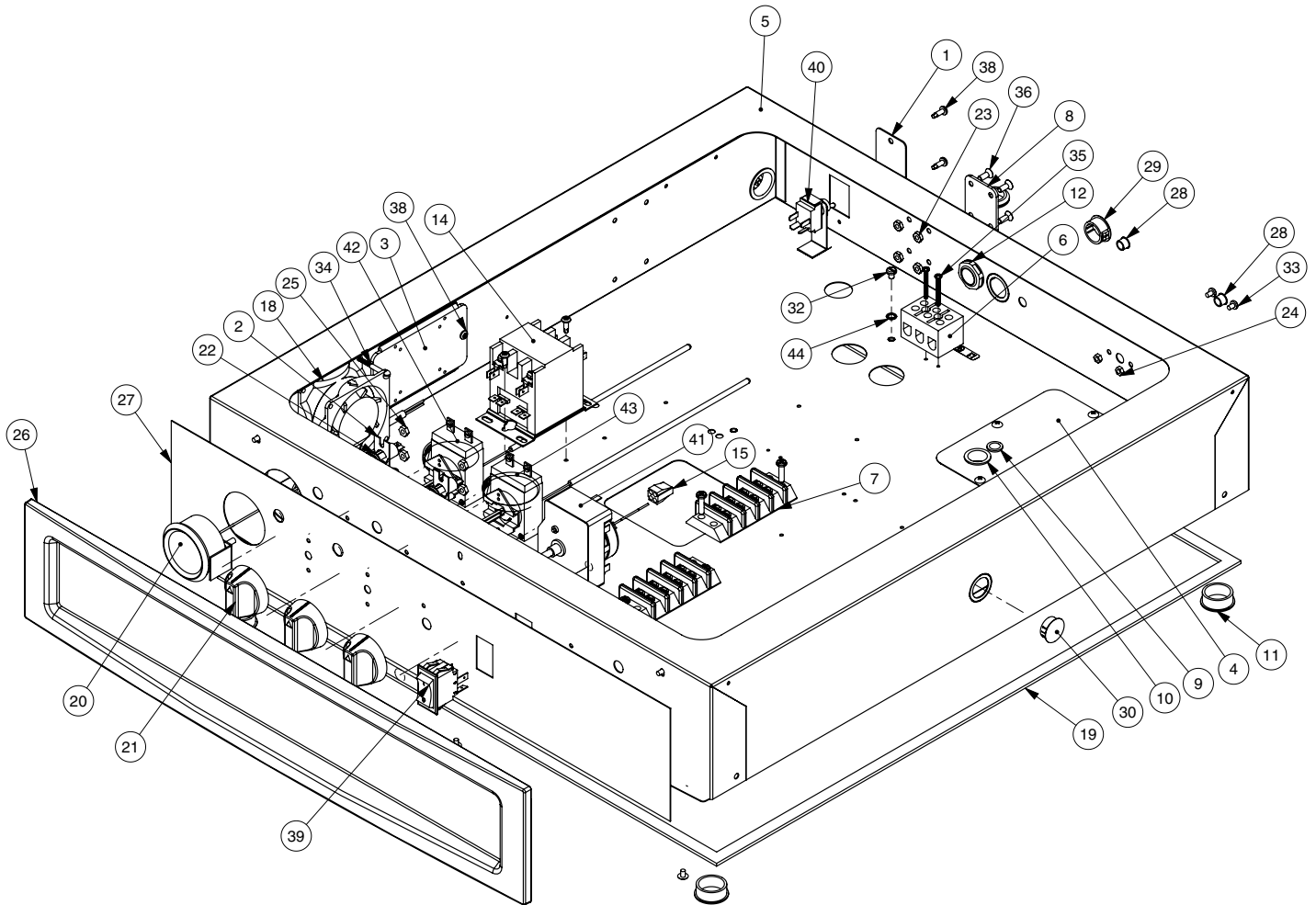

Part numbers and drawings are subject to change without notice.

CABLE HEATING SERVICE KITS

No. 4880 MODEL 500-TH-II

includes:	
CB-3045	Cable Heating Element 134 feet
CR-3226	Ring Connector 4
IN-3488	Insulation Corner 1 foot
BU-3105	Shoulder Bushing 4
BU-3106	Cup Bushing 4
ST-2439	Stud 4
NU-2215	Hex Nut 8
SL-3063	Insulating Sleeve 4
TA-3540	Electrical Tape 1 roll

No. 4881 750-,1000-TH-II

includes:	
CB-3045	Cable Heating Element 210 feet
CR-3226	Ring Connector 12
IN-3488	Insulation Corner 1 foot
BU-3105	Shoulder Bushing 12
BU-3106	Cup Bushing 12
ST-2439	Stud 12
NU-2215	Hex Nut 24
SL-3063	Insulating Sleeve 12
TA-3540	Electrical Tape 1 roll

SERVICE

ELECTRONIC COMPONENTS PARTS LIST B

MODEL >		500-TH-II		750-TH-II		1000-TH-II 1000-TH-II-SPLIT	
ITEM	DESCRIPTION	PART NO.	QTY	PART NO.	QTY	PART NO.	QTY/EA
1	SWITCH COVER	11133	1	11133	1	11133	1
2	BRKT, PILOT LIGHT MTG	1004360	2	1004360	2	1004360	2
3	HEAT SINK	1005836	1	1005836	1	1005836	1
4	ACCESS COVER	1009990	1	1009990	1	1009990	1
5	BONNET SPOT ASSEMBLY	5010731	1	5009854		5009188	1
6	T-BLOCK	BK-3019	1	BK-3019	1	BK-3019	1
7	TERMINAL BLOCK	BK-3023	2	BK-3023	2	BK-3023	2
8	BRACKET, TETHER, 208-240V	BT-26884	1	BT-26884	1	BT-26884	1
9	1/2" HOLE BUSHING	BU-3006	2	BU-3006	2	BU-3006	2
10	7/8" SNAP BUSHING	BU-3007	1	BU-3007	1	BU-3007	1
11	1 1/8" SNAP BUSHING	BU-3378	8	BU-3378	8	BU-3378	8
12*	BUSHING, STRAIGHT, STRAIN RELIEF	BU-3964	1	BU-3964	1	BU-3964	1
13*	CORDSET, 230V	CD-3922	1	CD-3922	1	CD-3922	1
	CORDSET, 120V	CD-3397	1	CD-3397	1	CD-3397	1
14	CONTACTOR 208/240V, 3 POLE 25 AMP	CN-3052	1	CN-3052	1	CN-3052	1
	CONTACTOR 120V, 2 POLE 25 AMP	CN-3487	1	CN-3487	1	CN-3487	1
15	CONNECTOR, PUSH WIRE	CR-34056	1	CR-34056	1	CR-34056	1
16*	CONNECTOR, DUAL SPADE, 3/16 230V	CR-33250	1	CR-33250	1	CR-33250	1
17*	CONNECTOR, T-BLOCK JUMPER	CR-34841	2	PG-3559	1	CR-34841	2
18	FAN, 3" BOX, 230V (208-240V, 230V)	FA-34524	1	FA-34524	1	FA-34524	1
	FAN, BOX, 115V (120V)	FA-3973	1	FA-3973	1	FA-3973	1
19	1/2" SELF ADHESIVE GASKET	GS-2019	8	GS-2019	8	GS-2019	8
20	GAUGE, TEMP, 100-400 DEG	GU-34197	1	GU-34197	1	GU-34197	1
21	KNOB, THERMOSTAT / TIMER	KN-26568	3	KN-26568	3	KN-26568	3
22	WHITE PILOT LIGHT 250V	LI-3951	2	LI-3951	2	LI-3951	2
	WHITE PILOT LIGHT 110V (120V ONLY)	LI-3027	2	LI-3027	2	LI-3027	2
23	NUT, 10-32, NF HEX MS, #18-8 S/S	NU-2215	4	NU-2215	4	NU-2215	4
24	M4-0.7 HEX NUT 18-8	NU-22286	2	NU-22286	2	NU-22286	2
25	NUT, HEX #8-32	NU-2296	4	NU-2296	4	NU-2296	4
26	CONTROL PANEL BEZEL	PE-26565	1	PE-26566	1	PE-26567	1
27	CONTROL PANEL OVERLAY	PE-27551	1	PE-26711	1	PE-26692	1
28	PLUG, 3/8" HOLE	PG-25574	2	PG-25574	2	PG-25574	2
29	PLUG, 7/8" HOLE	PG-3559	1	PG-3559	1	PG-3559	1
30	PLUG, 13/16" HOLE	PG-3589	2	PG-3589	2	PG-3589	2
31*	8-32 X 5/8" PAN HD*	SC-2077	4	SC-2077	4	SC-2077	4
32	10-32 X 1/4" PAN HD GROUND SCREW	SC-2190	1	SC-2190	1	SC-2190	1
33	SCREWS, M4-0.7X6MM PHIL	SC-22271	2	SC-22271	2	SC-22271	2
34	8-32 X 2 SLOT PAN HEAD 18-8 S.S.	SC-23154	2	SC-23154	2	SC-23154	2
35	6-32 X 1 1/4" ROUND HD	SC-2365	2	SC-2365	2	SC-2365	2
36	SCREW, 10-32X1/2, NF PHIL, FLAT	SC-23670	4	SC-23670	4	SC-23670	4
37*	8-32 X 1/4" PHIL SCREW	SC-2459	8	SC-2459	8	SC-2459	8
38	SCREW, 8-32X1/2T-410PH PAN HD	SC-25849	6	SC-25849	6	SC-25849	6
39	SWITCH, ROCKER, 125-277V, 20A	SW-34769	1	SW-34769	1	SW-34769	1
40	20A, TOGGLE SWITCH, 208-240V, 230V	SW-3528	1	SW-3528	1	SW-3528	1
41	TIMER, 12HR, 208-240V, 230V, 50/60HZ	TR-34542	1	TR-34542	1	TR-34542	1
	TIMER, 12HR, 120V, 60HZ	TR-34541	1	TR-34541	1	TR-34541	1
42	THERMOSTAT, HOLD	TT-3057	1	TT-3057	1	TT-3057	1
43	THERMOSTAT, COOK	TT-3329	1	TT-3329	1	TT-3329	1
44	STAR LOCK WASHER	WS-2467	1	WS-2467	1	WS-2467	1

*NOT SHOWN

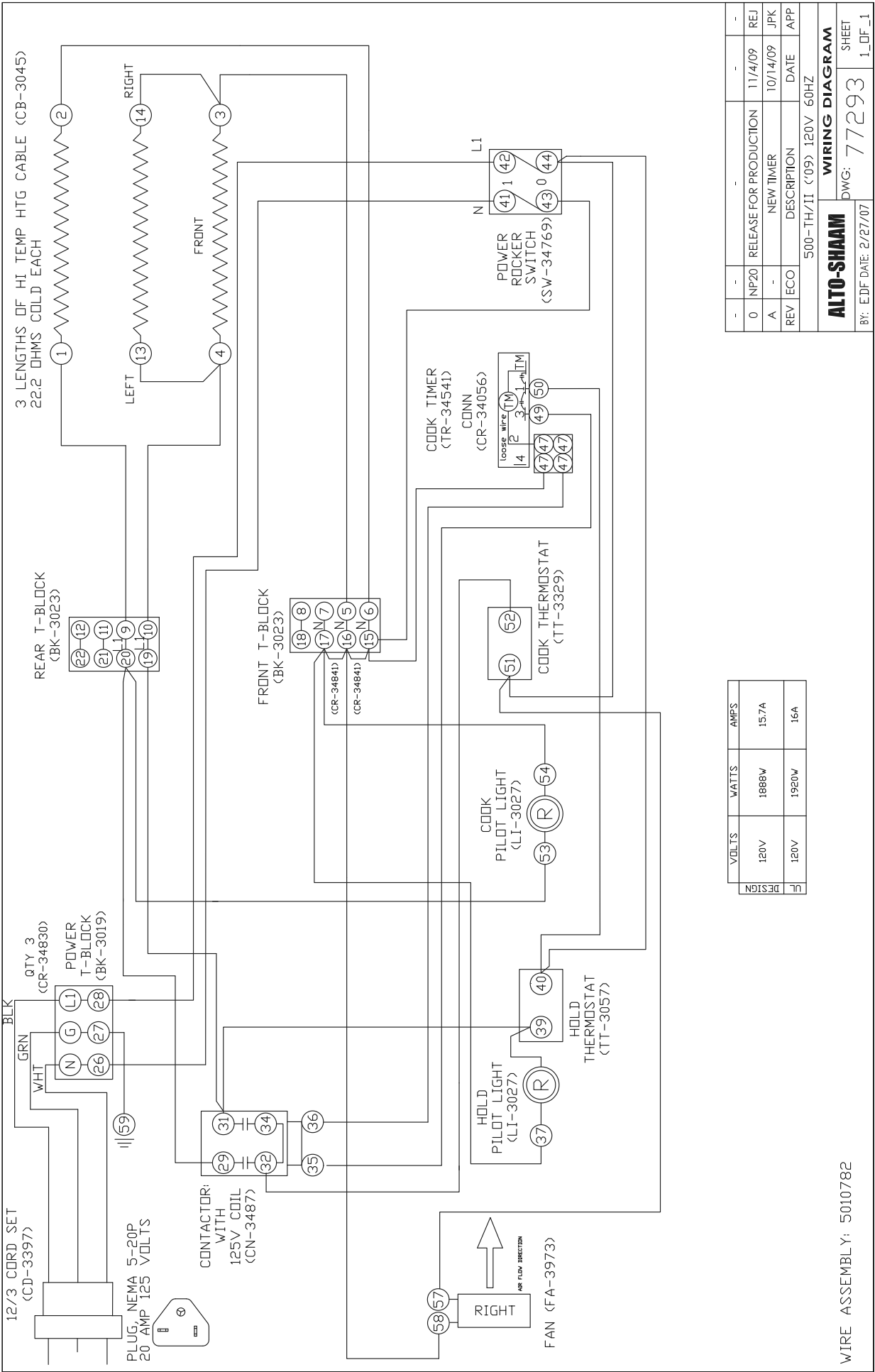

DESIGN	VOLTS	WATTS	AMPS
F	120V	1888W	15.7A
F	120V	1920W	16A

REV	ECO	DESCRIPTION	DATE	APP
0	NP20	RELEASE FOR PRODUCTION	11/4/09	REJ
A	-	NEW TIMER	10/14/09	JPK

500-TH/II ('09) 120V 60HZ
ALTO-SHAAM
 BY: EDF DATE: 2/27/07
 DWG: 77293
WIRING DIAGRAM
 SHEET 1_DF_1

WIRE ASSEMBLY: 5010782

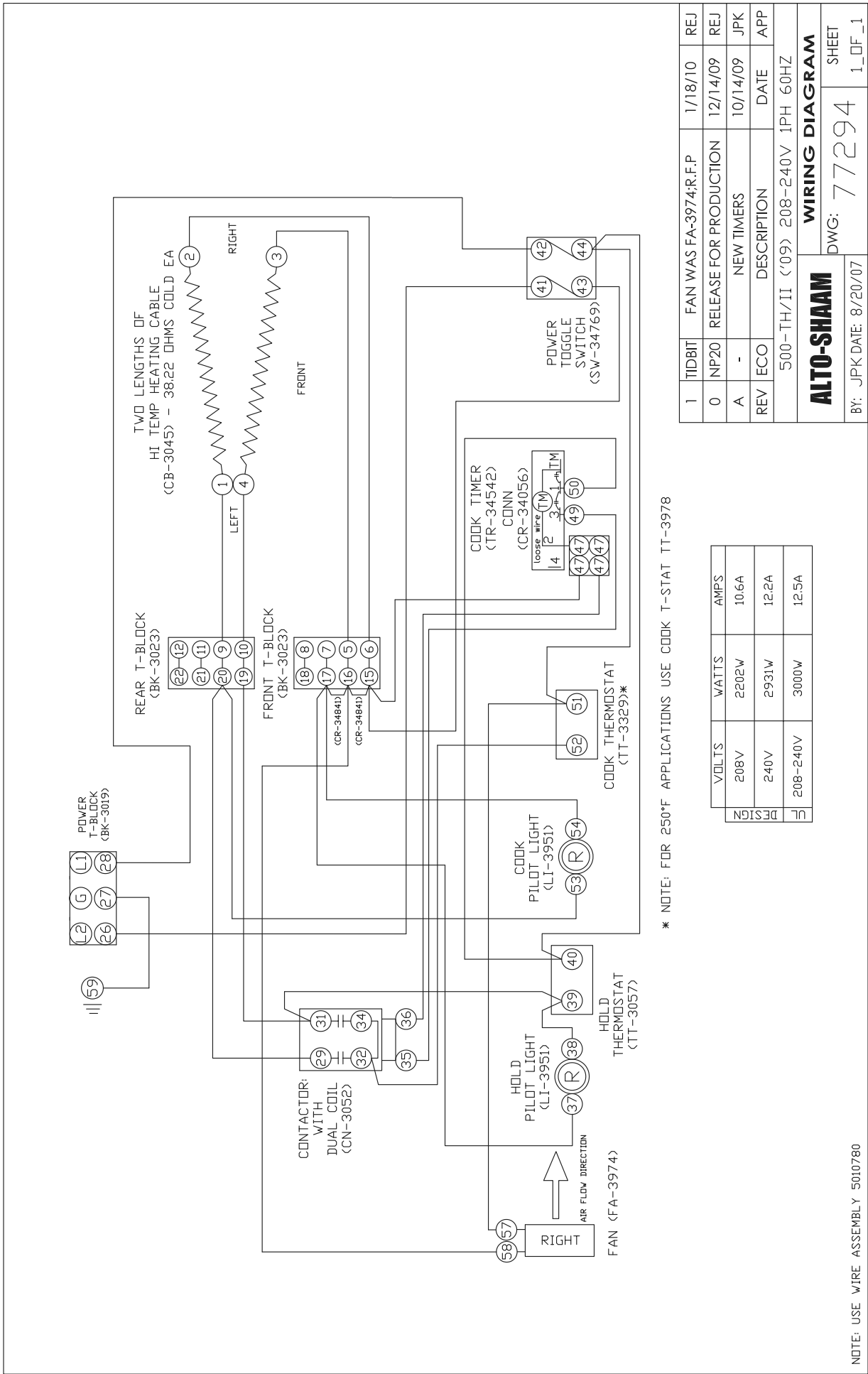

* NOTE: FOR 250°F APPLICATIONS USE COOK T-STAT TT-3978

DESIGN	VOLTS	WATTS	AMPS
	208V	2202W	10.6A
	240V	2931W	12.2A
F	208-240V	3000W	12.5A

1	TIDBIT	FAN WAS FA-3974;R.F.P	1/18/10	REJ
0	NP20	RELEASE FOR PRODUCTION	12/14/09	REJ
A	-	NEW TIMERS	10/14/09	JPK
REV	ECO	DESCRIPTION	DATE	APP
500-TH/II ('09) 208-240V 1PH 60HZ				
ALTO-SHAAM			WIRING DIAGRAM	
BY: JPK		DATE: 8/20/07	DWG: 77294	
				SHEET
				1_OF_1

NOTE: USE WIRE ASSEMBLY 5010780

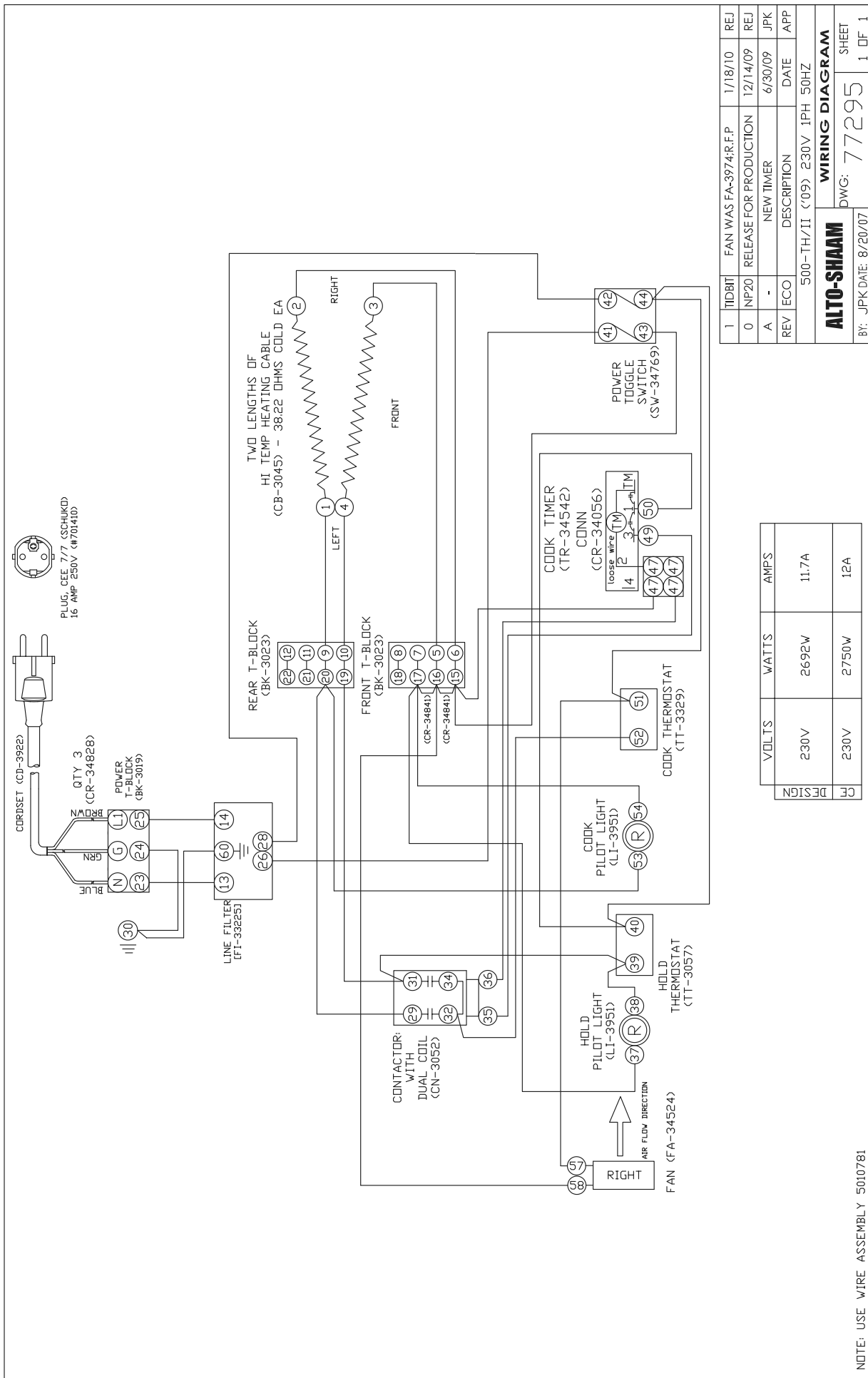

1	TIDBIT	FAN WAS FA-3974/R.F.P	1/18/10	REJ
0	NP20	RELEASE FOR PRODUCTION	12/14/09	REJ
A	-	NEW TIMER	6/30/09	JPK
REV	ECO	DESCRIPTION	DATE	APP
500-TH/II ('09) 230V 1PH 50HZ				
ALTO-SHAAM				
BY: JPK DATE: 8/20/07			DWG: 77295	
			WIRING DIAGRAM	
			SHEET 1_OF_1	

VOLTS	WATTS	AMPS
230V	2692W	11.7A
230V	2750W	12A

NOTE: USE WIRE ASSEMBLY 5010781

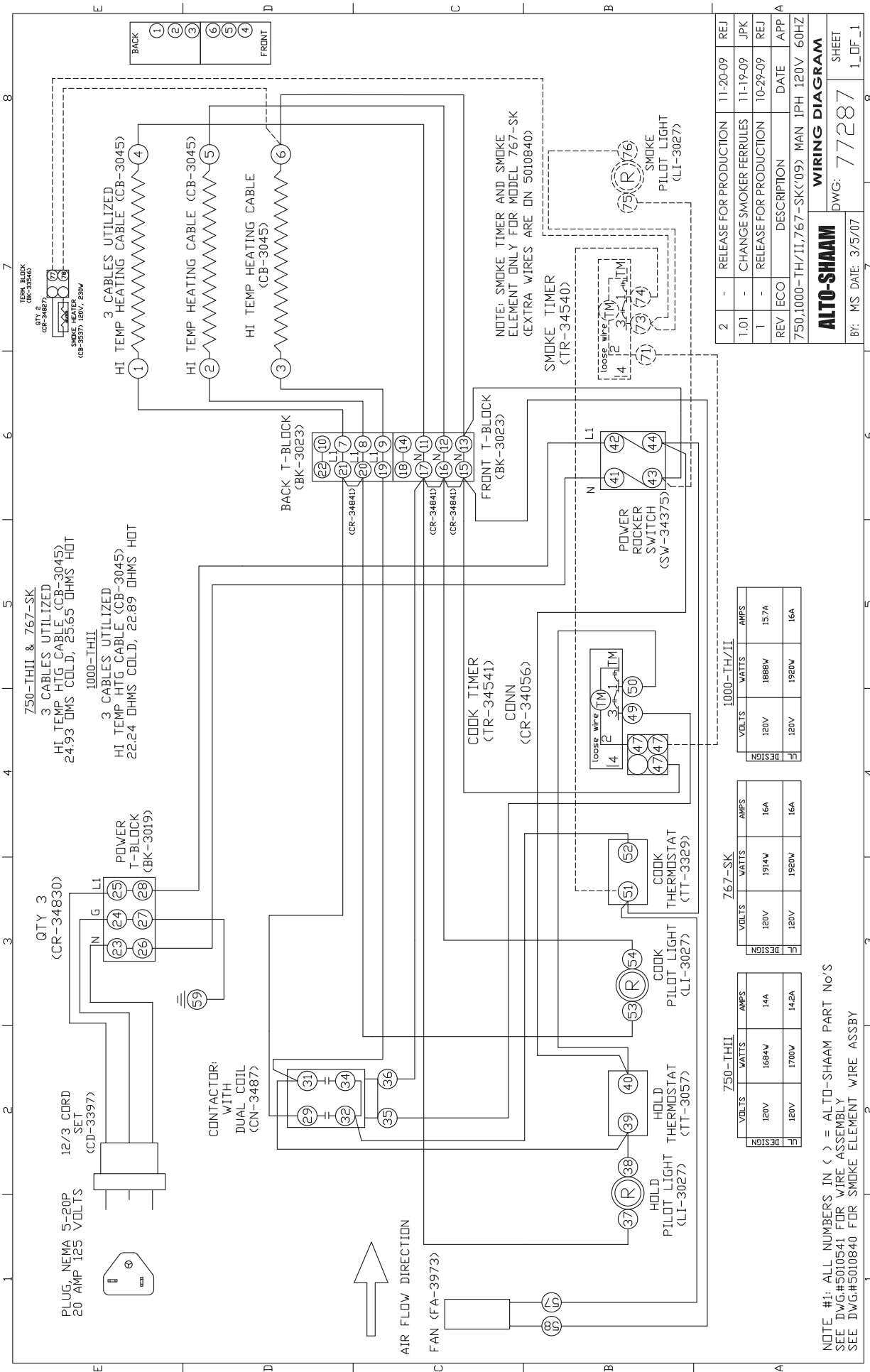

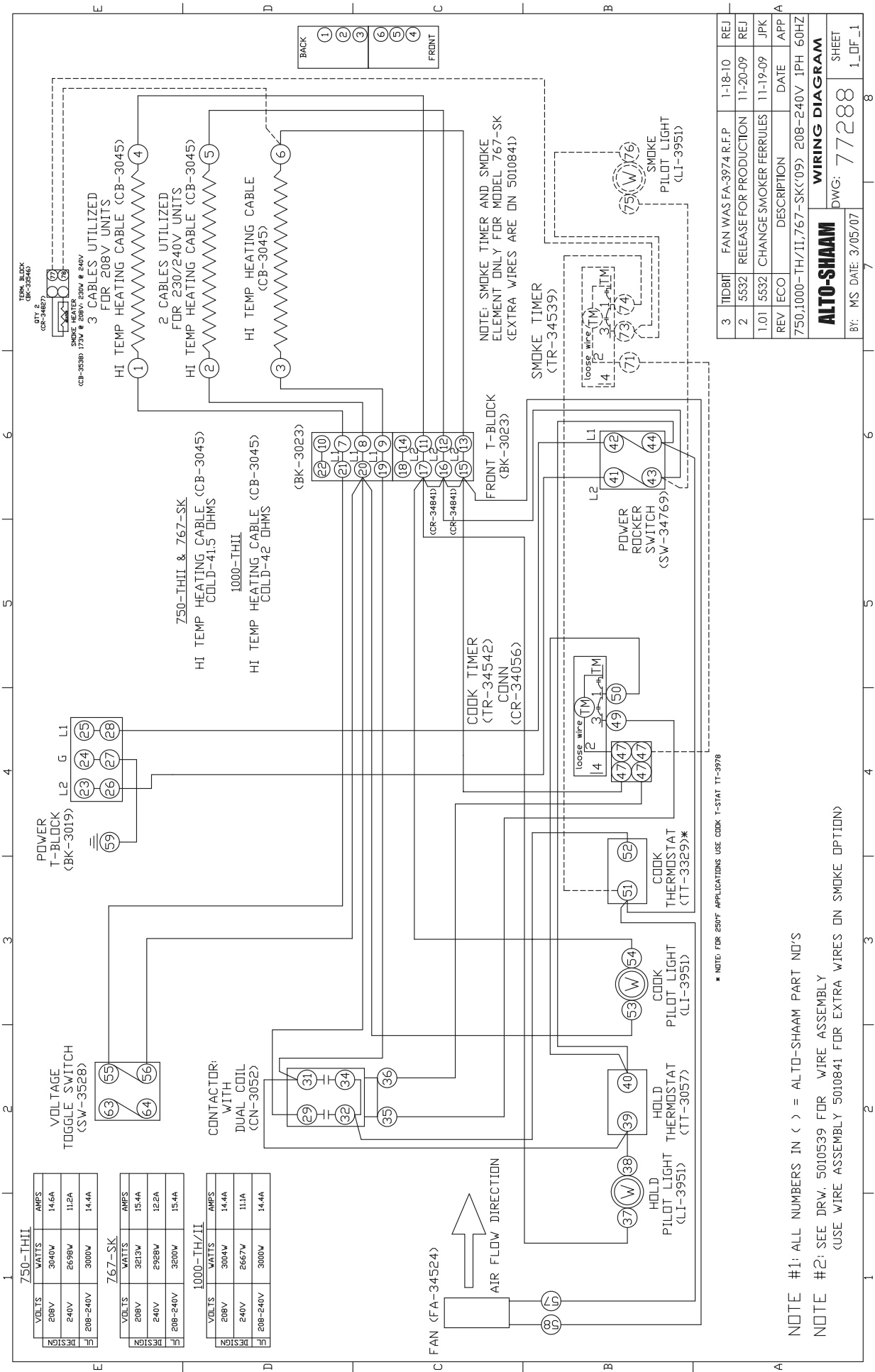

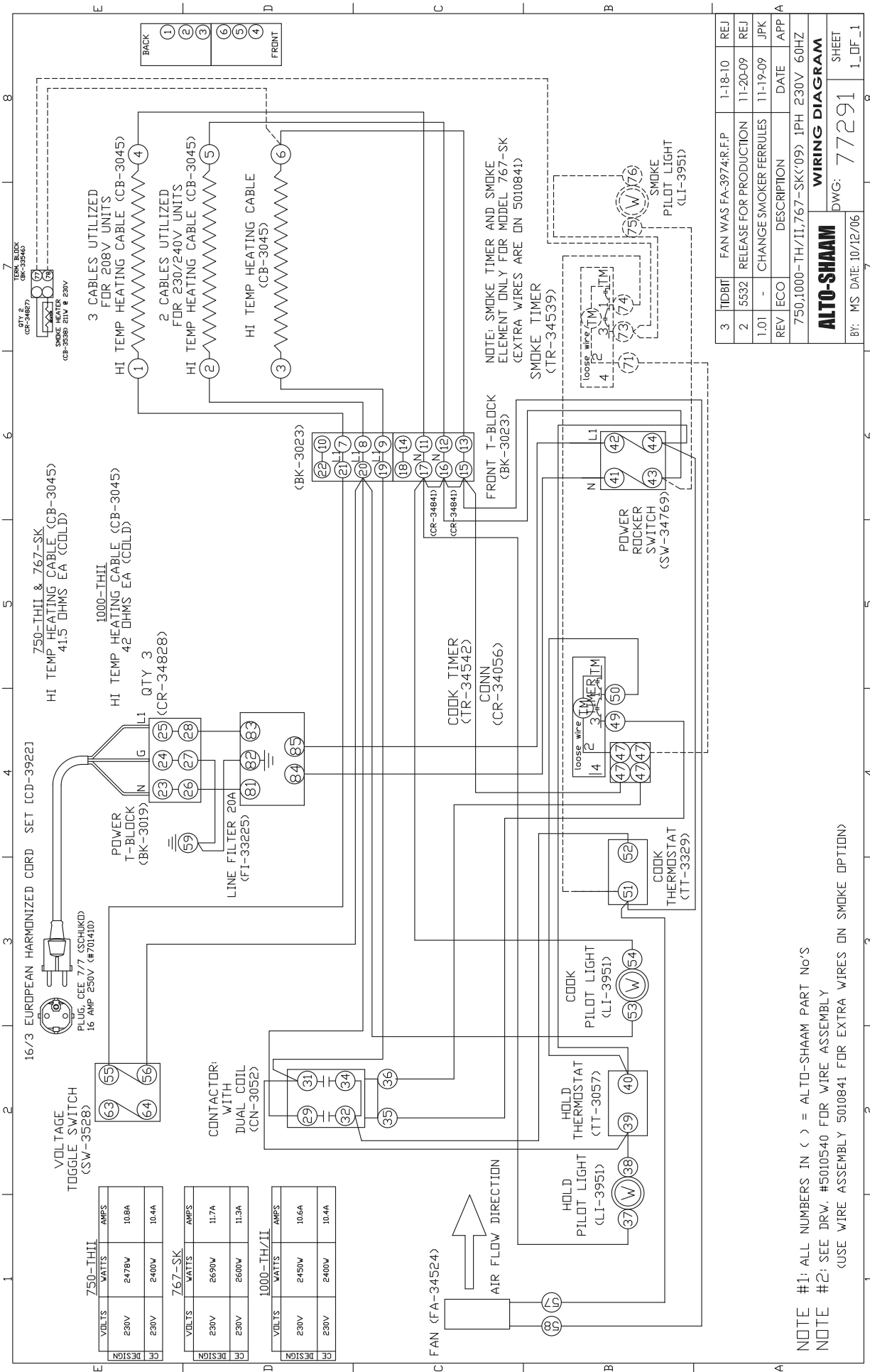

TRANSPORTATION DAMAGE and CLAIMS



All Alto-Shaam equipment is sold F.O.B. shipping point, and when accepted by the carrier, such shipments become the property of the consignee.

Should damage occur in shipment, it is a matter between the carrier and the consignee. In such cases, the carrier is assumed to be responsible for the safe delivery of the merchandise, unless negligence can be established on the part of the shipper.

1. Make an immediate inspection while the equipment is still in the truck or immediately after it is moved to the receiving area. Do not wait until after the material is moved to a storage area.
2. Do not sign a delivery receipt or a freight bill until you have made a proper count and inspection of all merchandise received.
3. Note all damage to packages directly on the carrier's delivery receipt.
4. Make certain the driver signs this receipt. If he refuses to sign, make a notation of this refusal on the receipt.
5. If the driver refuses to allow inspection, write the following on the delivery receipt:
Driver refuses to allow inspection of containers for visible damage.
6. Telephone the carrier's office immediately upon finding damage, and request an inspection. Mail a written confirmation of the time, date, and the person called.
7. Save any packages and packing material for further inspection by the carrier.
8. Promptly file a written claim with the carrier and attach copies of all supporting paperwork.

We will continue our policy of assisting our customers in collecting claims which have been properly filed and actively pursued. We cannot, however, file any damage claims for you, assume the responsibility of any claims, or accept deductions in payment for such claims.

LIMITED WARRANTY

Alto-Shaam, Inc. warrants to the original purchaser only that any original part that is found to be defective in material or workmanship will, at Alto-Shaam's option, subject to provisions hereinafter stated, be replaced with a new or rebuilt part.

The parts warranty period is as follows:

For the refrigeration compressor on Alto-Shaam Quickchillers™, five (5) years from the date of installation.

For the heating element on Halo Heat® cook/hold ovens, as long as the original purchaser owns the oven.

For all other parts, one (1) year from the date of installation or fifteen (15) months from the shipping date, whichever occurs first.

The labor warranty period is one (1) year from the date of installation or fifteen (15) months from the shipping date, whichever occurs first.

Alto-Shaam will bear normal labor charges performed during standard business hours, excluding overtime, holiday rates or any additional fees.

To be valid, a warranty claim must be asserted during the applicable warranty period. This warranty is not transferable.

THIS WARRANTY DOES NOT APPLY TO:

1. Calibration.
2. Replacement of light bulbs and/or the replacement of display case glass due to damage of any kind.
3. Equipment damage caused by accident, shipping, improper installation or alteration.
4. Equipment used under conditions of abuse, misuse, carelessness or abnormal conditions, including but not limited to, equipment subjected to harsh or inappropriate chemicals, including but not limited to, compounds containing chloride or quaternary salts, poor water quality, or equipment with missing or altered serial numbers.
5. Damage incurred as a direct result of poor water quality, inadequate maintenance of steam generators and/or surfaces affected by water quality. Water quality and required maintenance of steam generating equipment is the responsibility of the owner/operator.
6. Damage caused by use of any cleaning agent other than Alto-Shaam's Combitherm® Cleaner, including but not limited to damage due to chlorine or other harmful chemicals. **Use of Alto-Shaam's Combitherm® Cleaner on Combitherm® ovens is highly recommended.**
7. Any losses or damage resulting from malfunction, including loss of product or consequential or incidental damages of any kind.
8. Equipment modified in any manner from original model, substitution of parts other than factory authorized parts, removal of any parts including legs, or addition of any parts.

This warranty is exclusive and is in lieu of all other warranties, express or implied, including the implied warranties of merchantability and fitness for a particular purpose. In no event shall Alto-Shaam be liable for loss of use, loss of revenue or profit, or loss of product, or for any indirect, special, incidental, or consequential damages. No person except an officer of Alto-Shaam, Inc. is authorized to modify this warranty or to incur on behalf of Alto-Shaam any other obligation or liability in connection with Alto-Shaam equipment.

Effective 02/09



RECORD THE MODEL AND SERIAL NUMBER OF THE APPLIANCE FOR EASY REFERENCE.
ALWAYS REFER TO BOTH MODEL AND SERIAL NUMBER IN ANY CONTACT WITH ALTO-SHAAM REGARDING THIS APPLIANCE.

Model: _____ Date Installed: _____
Voltage: _____ Purchased From: _____
Serial Number: _____

W164 N9221 Water Street • P.O. Box 450 • Menomonee Falls, Wisconsin 53052-0450 • U.S.A.

PHONE: 262.251.3800 • 800.558-8744 USA/CANADA

FAX: 262.251.7067 • 800.329.8744 U.S.A. ONLY

www.alto-shaam.com

PRINTED IN U.S.A.