

Repair Parts List

MODEL NUMBER

KFC2W2

MANUFACTURING
NUMBER

P1331410M

COMMERCIAL MICROWAVE

When requesting service or ordering parts, always provide the following information:

- Product Type
- Part Number
- Model Number
- Part Description

Amana[®]
HIGH PERFORMANCE HAS A NAME™

PART OF  FOODSERVICE GROUP

December 15 2006

Section: TRAY, GREASE SHIELD, CABINET,

Model: KFC2W2_P1331410M

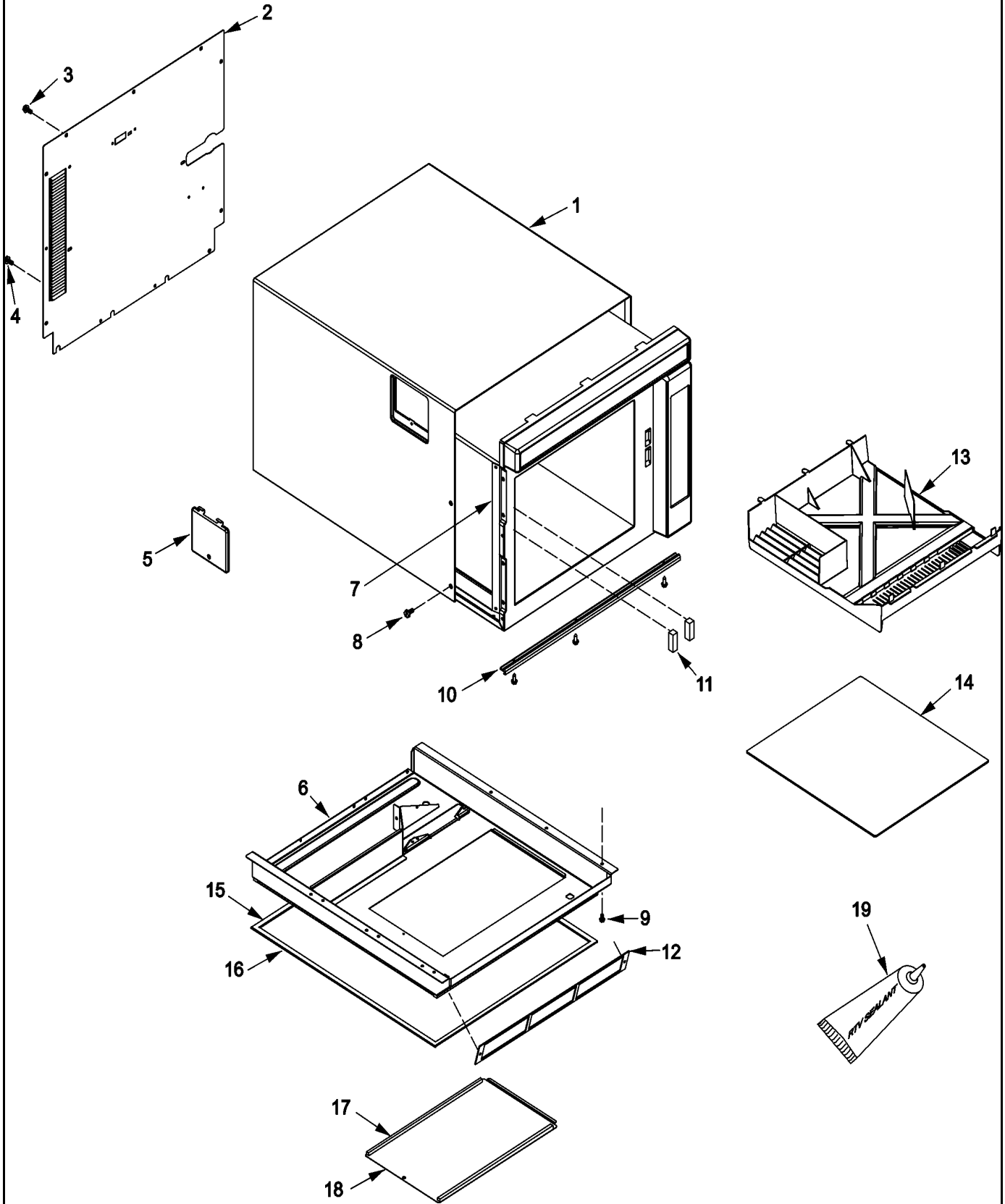

Section: TRAY, GREASE SHIELD, CABINET,

No.	Part No.	Description	Series Qty
1	10908901Q	WRAPPER-OC (SS)	1
2	R0156970	ASSY, ACCESS PANEL (REAR)	1
3	M0216703	SCREW ***	12
4	M0216716	SCREW	3
- N	M0288213	CLIP	1
-	M0249632	SCREW, T F	1
5	10785608	COVER LIGHT (SS)	1
6	10790304Q	BASE ASSY-GASKETS, ACCESS PNL	1
-	M0231717	SCREW, TF	2
7	12189003	BRACKET,HINGE SUPPORT	1
8	M0249632	SCREW, T F	4
9	M0220417	SCREW	6
-	M0249632	SCREW, T F	3
10 N	10909001	TRIM-OC (BRUSHED)	1
11	3010003001	SUPPORT-TRAY	2
-	M0274066	WASHER, NYLON	2
12	10853102	GRILLE, AIR INLET	1
-	M0209701	SCREW, DECORATIVE	2
13	10766601	SHIELD, GREASE	1
14	R0156942	TRAY-CERAMIC FLOOR W/SEALER	1
15	59001646	BASEPAN GASKET-CUT	2
16	59001647	BASEPAN GASKET-CUT	2
17	A3030301	GASKET (INCH)	2
18	10782402	BOTTOM ACCESS PANEL	1
-	M0216703	SCREW ***	1
19	M0275598	SEALER	1

Section: DOOR

Model: KFC2W2_P1331410M

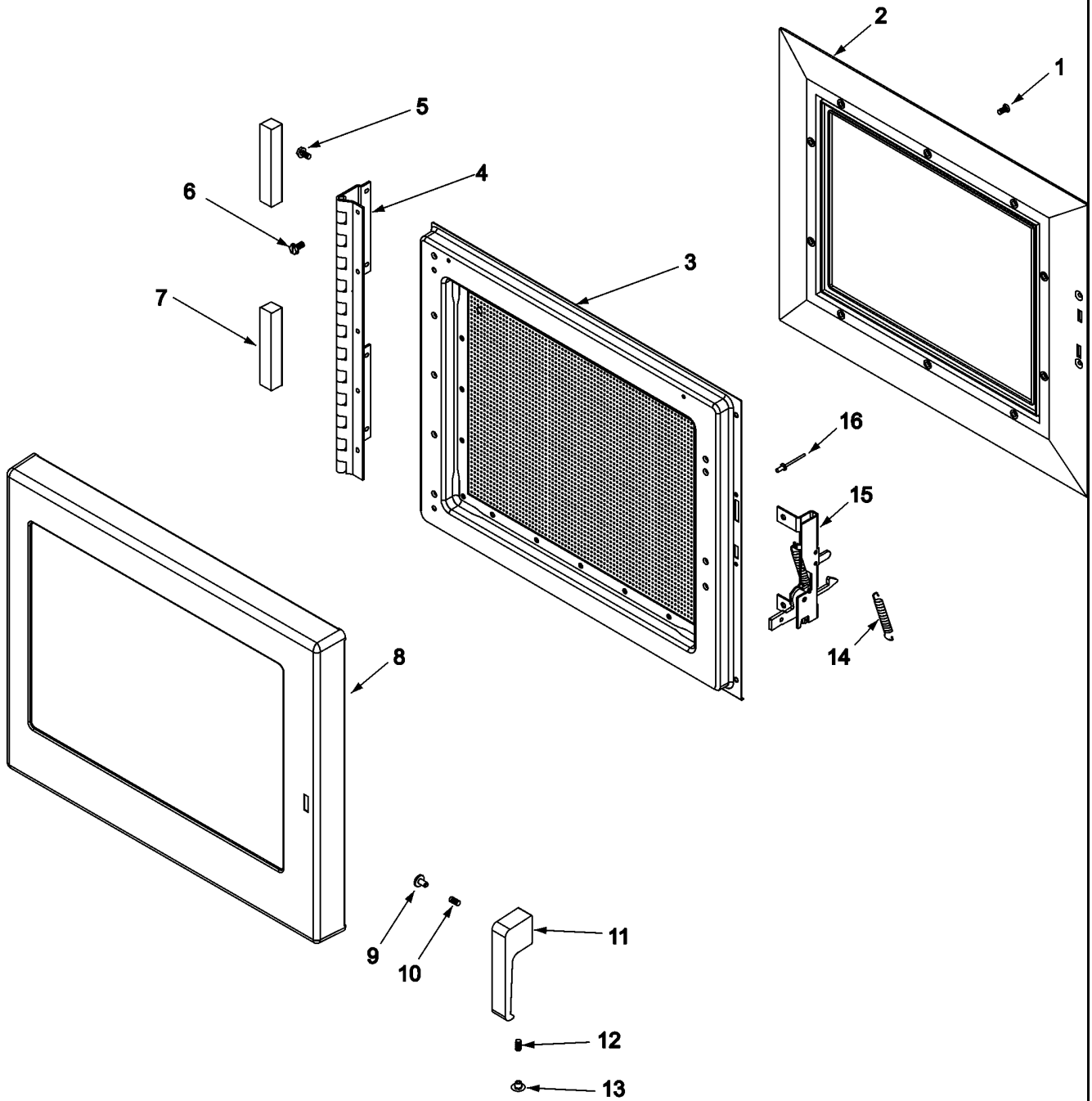

Section: DOOR

No.	Part No.	Description	Series Qty
1	67003392	SCREW-HI LO Y-DRIVE HEAD	10
-	R0193574	MAGNETIC Y-DRIVE BIT	1
-	20001136	NON-MAGNETIC Y-DRIVE BIT	1
2	12002103	KIT, INNER DOOR/WINDOW ASSY	1
3	D7683729	WELDMENT-INNER DOOR (BLK)	1
4	C8961811	HINGE-DOOR	1
5	M0216716	SCREW	4
6	M0216703	SCREW ***	5
7	A3263904	GASKET	2
8	R0156918	OUTER DOOR/LENS RETAINER ASSY	1
9	12360703	PLUG, BUTTON (BLK) Note: PLUG, BUTTON (BLK) (SIDE)	1
10	M0208943	SET SCREW Note: SET SCREW (SIDE)	1
11	12490901	HANDLE, DOOR	1
12	M0208342	SCREW, SET Note: SCREW, SET (BOTTOM)	1
13	M0310305	PLUG, BUTTON (WHT) Note: PLUG, BUTTON (WHT) (BOTTOM)	1
14	C8893502	SPRING, DOOR LATCH	1
15	R0000282	LATCH KIT	1
16	A4539601	POP RIVET	2

12/06 *Color Code (-)=Not Shown #=Series, Serial Prefix or Run No., N=Not Available

Section: FUSES, ANTENNAS, BLOWER, DUCTS,

Model: KFC2W2_P1331410M

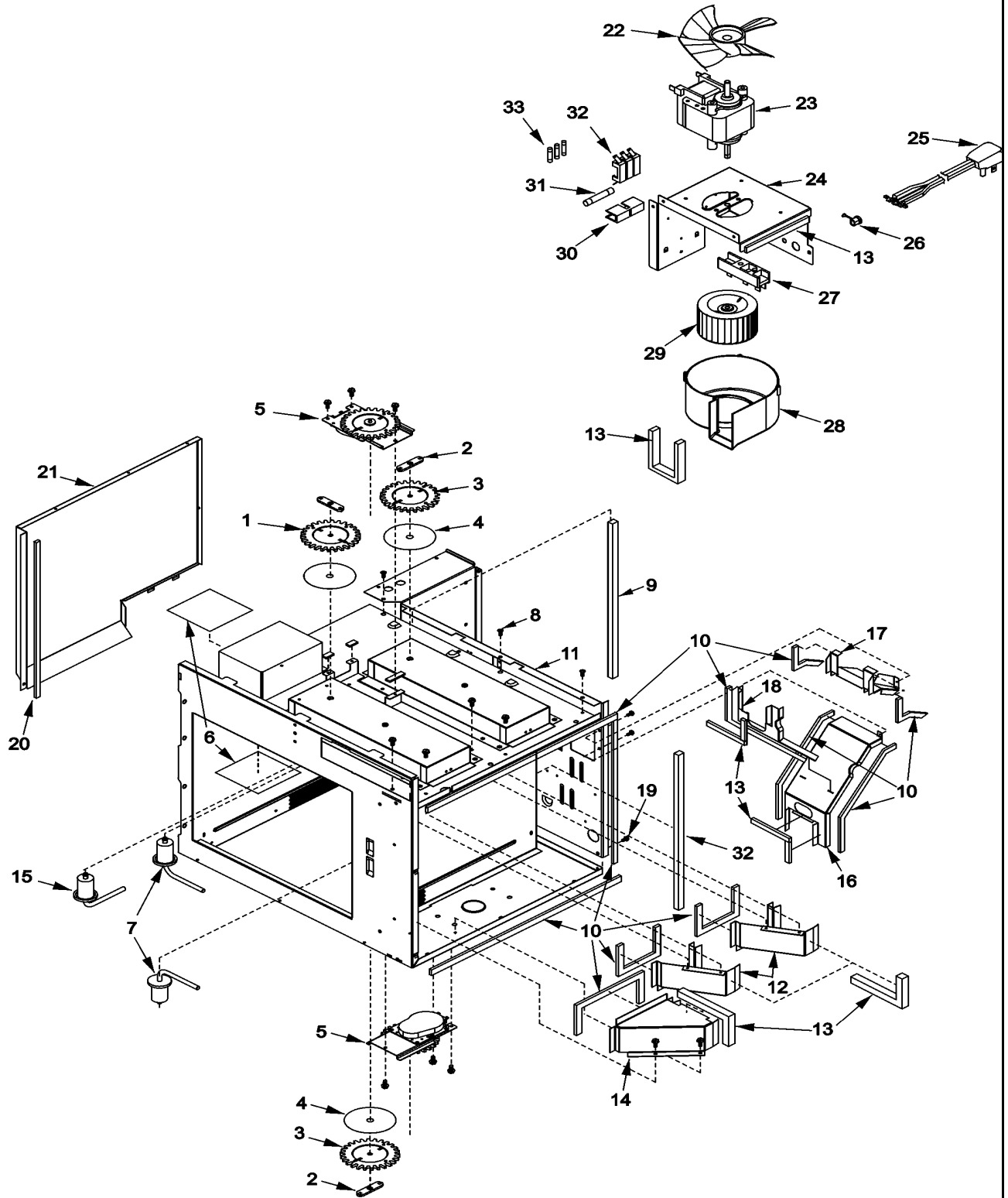

Section: FUSES, ANTENNAS, BLOWER, DUCTS,

No.	Part No.	Description	Series Qty
1	12570102	GEAR,SPUR (GRAY)	1
2	12570201	RETAINER,GEAR SHAFT	3
3	12570101	GEAR,SPUR	2
4	10903002	WASHER. SPUR GEAR	3
-	M0231717	SCREW, TF	6
5	R0130263	MOTOR-ANTENNA STIRRER (230V)	2
6	B8367701	WINDOW, OVEN LIGHT	2
7	R0130262	ANTENNA (STIRRER)	2
8	M0200316	SCREW	7
9	10966601	GASKET, NEOPRENE	1
10	A3030330	GASKET,PER FT	11
11	59001129	PANEL, PARTITION	1
12	R0156984	TOP EXHAUST DUCT-W/GASKET	2
-	M0216703	SCREW ***	4
13	A3030303	GASKET (PER FOOT)	6
14	R0156985	BOTTOM EXHAUST DUCT-W/GASKET	1
-	M0216703	SCREW ***	2
15	R0130261	ANTENNA, TOP FRONT (BLUE)	1
16	R0156987	BOTTOM DIVIDER DUCT-W/GASKET	1
17	R0156986	REAR DIVIDER DUCT-W/GASKET	1
-	M0216515	SCREW	1
-	M0216515	SCREW	1
18	10989601	DIVIDER, TOP FLOW	1
19	5078-CC	SCREW	4
20	A3030301	GASKET (INCH)	1
21	10781901	DUCT, EXHAUST	1
22	B5706704	FAN BLADE	1
23	12138106	MOTOR,BLOWER	1
-	M0216515	SCREW	3
24	59001632	BRACKET,BLOWER	1
25	10098906	POWER CORD	1
26	M0370011	RELIEF-STRAIN	1
-	M0234117	SCREW	1
27	B5677203	TERMINAL BLOCK	1
-	M0216517	SCREW	4
28	12552001	SCROLL,BLOWER	1
29	C3670809	WHEEL, BLOWER	1
30	10091101	FUSE HOLDER	1
31	M0805205	FUSE- 30A	1
-	M0234117	SCREW	2
32	12136502	BLOCK-3 POLE FUSE	1
33	M0805102	FUSE 15 AMP	3

12/06

*Color Code (-)=Not Shown #=Series, Serial Prefix or Run No., N=Not Available

Section: ELECTRICAL COMPONENTS

Model: KFC2W2_P1331410M

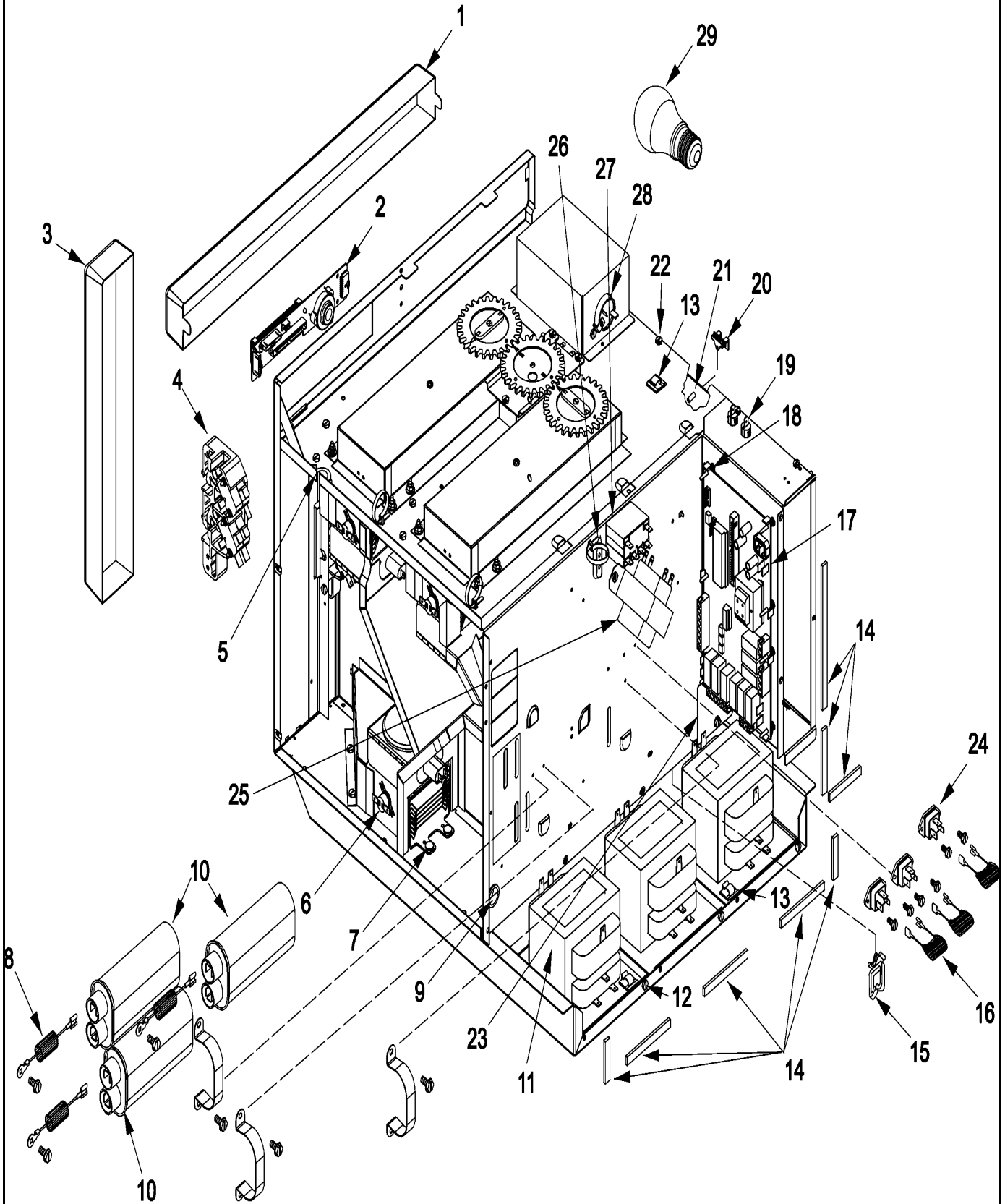

Section: ELECTRICAL COMPONENTS

No.	Part No.	Description	Series Qty
1	R0131508	TOUCH PANEL(TOP)	1
-	M0231717	SCREW, TF	2
2	12502401	BOARD,DISPLAY ***	1
-	M0234114	SCREW	3
-	M0231717	SCREW, TF	2
3	R0130109	TOUCH PANEL(SIDE)	1
-	M0216517	SCREW	2
4	59001114	SWITCH, INTERLOCK	1
5	12164101	GROMMET-RUBBER	1
-	M0229916	SCREW T.C	6
6	B5684124	CUTOUT-THERMAL MAGNETRON	3
7	10489402	MAGNETRON-T	3
-	M0216515	SCREW	3
8	B8383102	RECTIFIER	3
9	59001128	BUSHING, SNAP	1
-	M0216515	SCREW	6
10	59001160	CAPACITOR-.69	3
-	A4055405	STRAP, CAPACITOR	3
11	59001626	TRANSFORMER-HV	3
12	M0216716	SCREW	3
13	M0104106	CLIP	3
14	A3030301	GASKET (INCH)	8
15	B5667304	WIRE CLIP	1
16	10172901Q	SNUBBER ASSEMBLY	3
17	59001121	NET-BOARD,HV AMANA PROG-KFC2	1
18	M0590602	SUPPORT P-C BD A	7
19	M0325401	BUSHING,TERMINAL	2
-	M0234422	SCREW	1
20	59001921	THERMAL CUTOUT	1
21	M0308801	CAP, PROTECTIVE-THREADED (RED)	1
22	M0231617	SCREW,TF	4
23	10847601	PLATE, PARTITION	1
-	M0200316	SCREW	1
24	R0157373	KIT, TRIAC ASSY	3
-	M0216515	SCREW	6
25	59001630	TRANSFORMER-AUTO	1
-	M0216515	SCREW	1
26	M0322202	TIE WIRE	3
27	12492202	RELAY	1
28	B8371401	RECEPTACLE, LAMP	1
-	M0231717	SCREW, TF	1
29	10664502	LAMP 41W	1

12/06

*Color Code (-)=Not Shown #=Series, Serial Prefix or Run No., N=Not Available

Section: SUPPLEMENTAL INFORMATION

No.	Part No.	Description	Series Qty
1	RS2240003	MNL,SVC-COMM'L MICRO	1
2	N 59001907	USE & CARE	1
3	N 59001679	MANUAL, PRODUCT SAFETY	1
4	N 59001908	INSTR,QUICK START-COMM'L MICRO	1
5	59001639	MENU LABEL	1
6	R0193574	MAGNETIC Y-DRIVE BIT	1
7	59001635	HARNESS-INTERLOCK/DISPLAY BD	1
8	R0130265	HARNESS, HV BOARD TO DISPLAY	1
9	12543401	HARNESS-OVEN LIGHT	1
10	12598201	HARNESS, LOWER ANTENNA MOTOR	1
11	59001137	HARNESS-HI VOLT	1
12	59001631	HARNESS- OVEN	1
13	20001136	NON-MAGNETIC Y-DRIVE BIT	1
14	12002484	KIT-CAV- 3 TUBE "S" CHASSIS	1

Section: WIRING INFORMATION

Model: KFC2W2_P1331410M

SCHEMATIC CONDITION: DOOR OPEN 208/230V 60Hz 3-WIRE

