

Service Manual

Commercial Q-ing Oven



MCMOC24

MCMOC24T

P2004822M & P2004825M

P2004823M & P2004826M

TABLE OF CONTENTS

IMPORTANT INFORMATION	1
IMPORTANT SAFETY INFORMATION	2-5
Oven Specifications	6
Oven Construction	7-11
Oven Performance Test.....	12
Component Test Procedures.....	13-16
Troubleshooting Chart.....	17-18
Wiring Diagram	19
Schematic Diagram.....	20
Appendix A	
Quick Start Reference Guide	A-1

Important Information

Important Notices for Servicers and Consumers

ACP will not be responsible for personal injury or property damage from improper service procedures. Pride and workmanship go into every product to provide our customers with quality products. It is possible, however, that during its lifetime a product may require service. Products should be serviced only by a qualified service technician who is familiar with the safety procedures required in the repair and who is equipped with the proper tools, parts, testing instruments and the appropriate service information. **IT IS THE TECHNICIANS RESPONSIBILITY TO REVIEW ALL APPROPRIATE SERVICE INFORMATION BEFORE BEGINNING REPAIRS.**

 WARNING
To avoid risk of severe personal injury or death, disconnect power before working/servicing on appliance to avoid electrical shock.

To locate an authorized servicer please contact:

ComServ Support Center



Web Site
WWW.ACPSOLUTIONS.COM

Telephone Number
1-866-811-8559 or 319-368-8195

E-Mail: commercialservice@acpsolutions.com

Recognize Safety Symbols, Words, and Labels

 DANGER

DANGER— Immediate hazards which **WILL** result in severe personal injury or death.

 WARNING
--

WARNING— Hazards or unsafe practices which **COULD** result in severe personal injury or death.

 CAUTION
--

CAUTION— Hazards or unsafe practices which **COULD** result in personal injury, product or property damage.

Important Safety Information



WARNING

Read the following information to avoid possible exposure to microwave radiation:

The basic design of the Microwave Oven makes it an inherently safe device to both use and service. However, there are some precautions which should be followed when servicing the microwave to maintain this safety. These are as follows:

1. Always operate the unit from an adequately grounded outlet. Do not operate on a two-wire extension cord.
2. Before servicing the unit (if unit is operable) perform the microwave leakage test.
3. The oven should never be operated if the door does not fit properly against the seal, the hinges or hinge bearings are damaged or broken; the choke is damaged, (pieces missing, etc.); or any other visible damage can be noted. Check the choke area to ensure that this area is clean and free of all foreign matter.
4. If the oven operates with the door open and produces microwave energy, take the following steps:
 - A. Tell the user not to operate the oven.
 - B. Contact ACP ComServ immediately.
5. Always have the oven disconnected when the outer case is removed except when making the "live" tests called for in the Service Manual. Do not reach into the equipment area while the unit is energized. Make all connections for the test and check them for tightness before plugging the cord into the outlet.
6. Always ground the capacitors on the magnetron filter box with an insulated-handle screwdriver before working in the high voltage area of the equipment compartment. Some types of failures will leave a charge in these capacitors and the discharge could cause a reflex action which could make you injure yourself.
7. Always remember that in the area of the transformer there is HIGH VOLTAGE. When the unit is operating keep this area clear and free of anything which could possibly cause an arc or ground, etc.
8. Do not for any reason defeat the interlock switches there is not valid reason for this action at any time; nor will it be condoned by ACP.
9. IMPORTANT: Before returning a unit to a customer, be sure to check for proper switch interlock action.
10. The Microwave Oven should never be operated with any components removed and/or bypassed or when any of the safety interlocks are found to be defective, or when any of the seal surfaces are defective, missing, or damaged.
11. All microwave ovens meet all requirements of the radiation control for Health and Safety Act of 1968. Due to measurement uncertainties, the maximum leakage for the field will be $4\text{mw}/\text{cm}^2$.
12. To ensure that the unit does not emit excessive microwave leakage and to meet the Department of Health and Human Services guidelines, check the oven for microwave leakage using a microwave oven leakage meter that complies with US Government CDRH/FDA/DHHS requirements and or any other local government requirements. The maximum leakage level allowed by ACP is $4\text{mw}/\text{cm}^2$.
13. If servicer encounters an emission reading over $4\text{mw}/\text{cm}^2$, the servicer is to cease repair and contact the ACP ComServ Department immediately for further direction. ACP will contact the proper Government Agency upon verification of the test results.

IMPORTANT SAFETY INSTRUCTIONS



Recognize this symbol as a **SAFETY** message



WARNING

When using electrical equipment, basic safety precautions should be followed to reduce the risk of burns, electrical shock, fire, or injury to persons including the following.

1. READ all instructions before using equipment.
2. READ AND FOLLOW the specific "PRECAUTIONS TO AVOID POSSIBLE EXPOSURE TO EXCESSIVE MICROWAVE ENERGY" on this page.
3. This equipment **MUST BE GROUNDED**. Connect only to properly GROUNDED outlet. See "GROUNDING / EARTHING INSTRUCTIONS" on page 5.
4. Install or locate this equipment **ONLY** in accordance with the installation instructions in this manual.
5. Some products such as whole eggs and sealed containers—for example, closed glass jars—are able to explode and **SHOULD NOT** be HEATED in this oven.
6. Use this equipment **ONLY** for its intended use as described in this manual. Do not use corrosive chemicals or vapors in this equipment. This type of oven is specifically designed to heat, cook, or dry food. It is not designed for industrial or laboratory use.
7. As with any equipment, **CLOSE SUPERVISION** is necessary when used by **CHILDREN**.
8. See door cleaning instructions on page A-4 of this owners manual.
9. **DO NOT** heat baby bottles in oven.
10. Baby food jars shall be open when heated and contents stirred or shaken before consumption, in order to avoid burns.
- 11 **DO NOT** operate this equipment if it has a damaged cord or plug, if it is not working properly, or if it has been damaged or dropped.
12. This equipment, including power cord, must be serviced **ONLY** by qualified service personnel. Special tools are required to service equipment. Contact nearest authorized service facility for examination, repair, or adjustment.
13. **DO NOT** cover or block louvers or other openings on equipment.
14. **DO NOT** store this equipment outdoors. **DO NOT** use this product near water – for example, near a kitchen sink, in a wet basement, a swimming pool, or a similar location.
15. **DO NOT** immerse cord or plug in water.
16. Keep cord **AWAY** from **HEATED** surfaces.
17. **DO NOT** let cord hang over edge of table or counter.
18. For commercial use only.

PRECAUTIONS TO AVOID POSSIBLE EXPOSURE TO EXCESSIVE MICROWAVE ENERGY

- A. **DO NOT** attempt to operate this oven with the door open since open door operation can result in harmful exposure to microwave energy. It is important not to defeat or tamper with the safety interlocks.
- B. **DO NOT** place any object between the oven front face and the door too allow soil or cleaner residue to accumulate on sealing surfaces.
- C. **DO NOT** operate the oven if it is damaged. It is particularly important that the oven door close properly and that there is no damage to the:
 1. door (bent)
 2. hinges and latches (broken or loosened)
 3. door seals and sealing surfaces.
- D. The oven should not be adjusted or repaired by anyone except properly qualified service personnel.

SAVE THESE INSTRUCTIONS

IMPORTANT SAFETY INSTRUCTIONS

WARNING

To avoid risk of fire in the oven cavity:

- a. DO NOT overcook food. Carefully attend oven when paper, plastic, or other combustible materials are placed inside the oven to facilitate cooking.
- b. Remove wire twist-ties from paper or plastic bags before placing bag in oven.
- c. If materials inside the oven ignite, keep oven door CLOSED, turn oven off and disconnect the power cord, or shut off power at the fuse or circuit breaker panel.
- d. DO NOT use the cavity for storage. DO NOT leave paper products, cooking utensils, or food in the cavity when not in use.

WARNING

Liquids such as water, coffee, or tea are able to be overheated beyond the boiling point without appearing to be boiling due to surface tension of the liquid. Visible bubbling or boiling when the container is removed from the microwave oven is not always present. THIS COULD RESULT IN VERY HOT LIQUIDS SUDDENLY BOILING OVER WHEN A SPOON OR OTHER UTENSIL IS INSERTED INTO THE LIQUID. To reduce the risk of injury to persons:

- i) Do not overheat the liquid.
- ii) Stir the liquid both before and halfway through heating it.
- iii) Do not use straight-sided containers with narrow necks.
- iv) After heating, allow the container to stand in the microwave oven for a short time before removing the container.
- v) Use extreme care when inserting a spoon or other utensil into the container.

CAUTION

To avoid personal injury or property damage, observe the following:

1. Do not deep fat fry in oven. Fat could overheat and be hazardous to handle.
2. Do not cook or reheat eggs in shell or with an unbroken yolk using microwave energy. Pressure may build up and erupt. Pierce yolk with fork or knife before cooking.
3. Pierce skin of potatoes, tomatoes, and similar foods before cooking with microwave energy. When skin is pierced, steam escapes evenly.
4. Do not operate equipment without load or food in oven cavity.
5. Microwave popcorn should not be popped in oven.
6. Do not use regular cooking thermometers in oven. Most cooking thermometers contain mercury and may cause an electrical arc, malfunction, or damage to oven.
7. Do not use metal utensils in oven.
8. Do not use aluminum foil in oven
9. Never use paper, plastic, or other combustible materials that are not intended for cooking.
10. When cooking with paper, plastic, or other combustible materials, follow manufacturer's recommendations on product use.
11. Do not use paper towels which contain nylon or other synthetic fibers. Heated synthetics could melt and cause paper to ignite.
12. Do not heat sealed containers or plastic bags in oven. Food or liquid could expand quickly and cause container or bag to break. Pierce or open container or bag before heating.
13. To avoid pacemaker malfunction, consult physician or pacemaker manufacturer about effects of microwave energy on pacemaker.
14. An authorized servicer MUST inspect equipment annually. Record all inspections and repairs for future use.

SAVE THESE INSTRUCTIONS

Important Safety Information

WARNING

PRECAUTIONS TO BE OBSERVED BEFORE AND DURING SERVICING TO AVOID POSSIBLE EXPOSURE TO EXCESSIVE MICROWAVE ENERGY, OR ELECTRICAL SHOCK. DISCONNECT POWER TO OVEN.

- Do not operate or allow oven to be operated with door open.
- Make the following safety checks on all ovens to be serviced before activating the magnetron or other microwave source, and make repairs as necessary:
 - Interlock operation
 - Proper door closing
 - Seal and sealing surfaces (arcing, wear, and other damage)
 - Damage to or loosening of hinges and latches
 - Evidence of dropping or abuse
- Before turning on microwave power for any service test or inspection within the microwave generating compartments, check the magnetron, waveguide or transmission line, and cavity for proper alignment, integrity, and connections.
- Any failed or misadjusted components in the interlock, monitor, door seal, and microwave generation and transmission systems shall be repaired, replaced or adjusted by procedures described in this manual before oven is released to the consumer.
- Check microwave leakage to verify compliance with the federal performance standard should be performed on each oven prior to release to the consumer.

Grounding Instructions

WARNING

To avoid risk of electrical shock, injury or death; make sure these grounding instructions are followed.

WARNING

Do not remove grounding prong when installing grounded appliance in a home or business that does not have three wire grounding receptacle, under no condition is grounding prong to be cut off or removed. It is the personal responsibility of the consumer to contact a qualified electrician and have properly grounded three prong wall receptacle installed in accordance with appropriate electrical codes.

WARNING

To avoid the risk of electrical shock or death, do not alter the plug.

WARNING

To avoid the risk of electrical shock or death, this equipment must be grounded.

This equipment **MUST** be grounded. In the event of an electrical short circuit, grounding reduces the risk of electric shock by providing an escape wire for the electric current. This oven is equipped with a cord having a grounding wire with a grounding plug. The plug must be plugged into an outlet that is properly installed and grounded.

Consult a qualified electrician or service if grounding instructions are not completely understood, or if doubt exists as to whether the equipment is properly grounded.

Do not use an extension cord. If the product power cord is too short, have a qualified electrician install an appropriate receptacle. This oven should be plugged into a separate 50 or 60 hertz circuit with the electrical rating as shown in the appropriate drawing. Models operate with a 208 or 230 supply voltage. When an oven is on a circuit with other equipment, an increase in cooking times may be required and fuses can be blown.

SPECIFICATIONS

Model	MCMOC24*
Configuration	Countertop or shelf
Control System	Touch, angled for easy viewing
Programmable Control Pads	10
Total Programmable Settings	100
Max. Cooking Time	10:00
Power Levels	11
Defrost	Yes
Time Entry Option	Yes
Microwave Distribution	Rotating antennas, top and bottom
Magnetrons	2
Display	LED
Stackable	Yes
Stage Cooking	Yes, 4
Door Opening	Automatic opening
Signal	Door opens automatically
Temp. Display	N/A
Exterior Dimensions	D**18 5/8" (473) W 13 5/8" (346) H 17 3/4" (451)
Cavity Dimensions	D 8 3/4" (222) W 11 3/4" (298) H 5 3/8" (136)
Usable Cavity Space	.319 cubic ft. (.009m3)
Exterior Finish	Stainless steel
Interior Finish	Stainless steel
Power Consumption	3100 W
Power Output*	2400 W* Microwave
Power Source	208/230V, 60 Hz, 20 A single phase
Frequency	2450 MHz
Product Weight	70 lbs. (32 kg.)
Ship weight (approx.)	73 lbs. (33 kg.)
Shipping Carton Size	H 20 5/8" (524) W 17" (432) H 22" (559)
UPS Shippable	ISTA 3A approved small parcel

Measurements in () and not specified are millimeters

* IEC 705 Tested

** Includes handle

OVEN CONSTRUCTION-

- Left Outer Panel
- Top Outer Panel
- Right Outer Panel
- Door

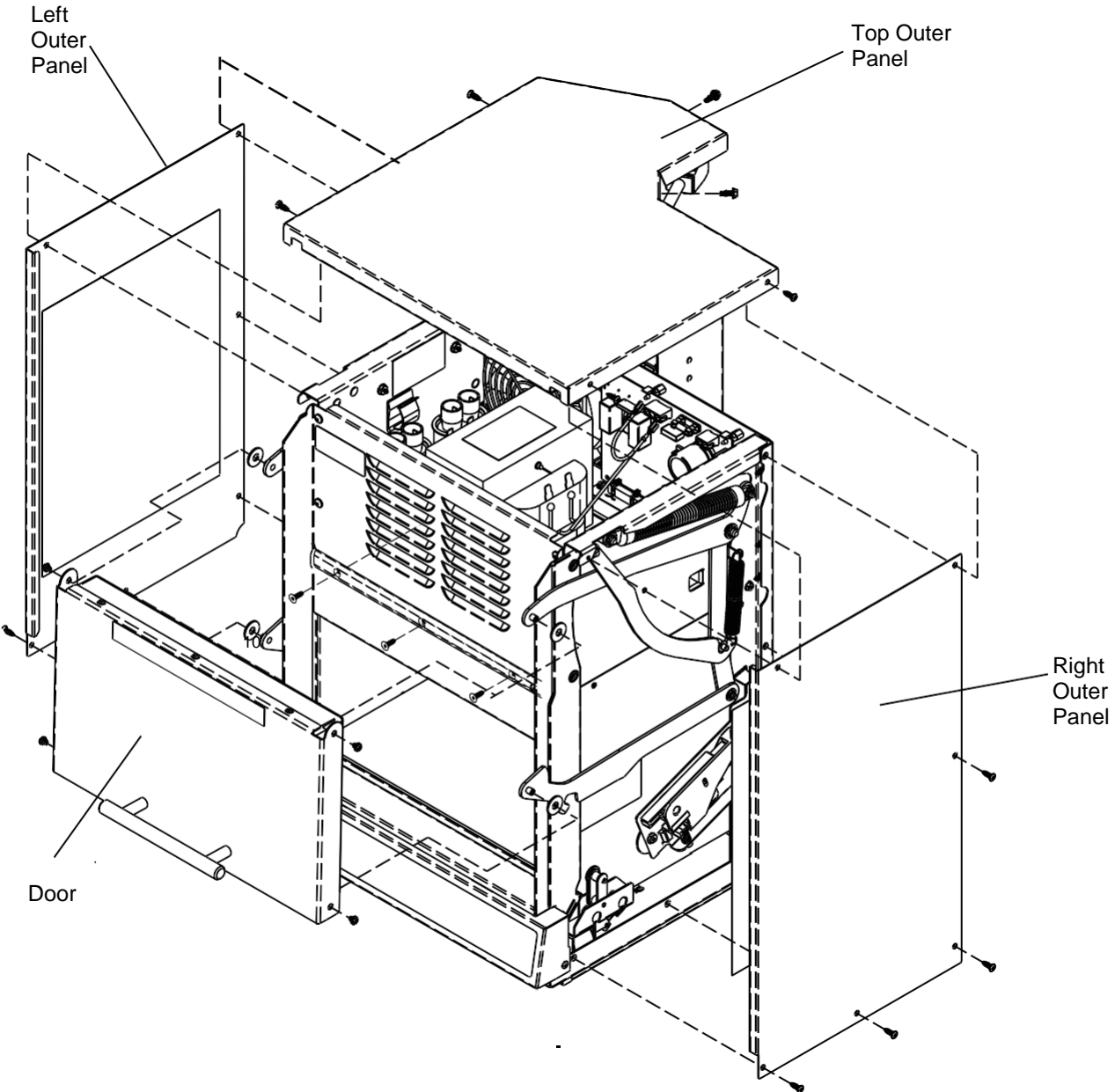

OVEN CONSTRUCTION-

Touch Panel Assembly
Escutcheon Control
Display Board
Retainer Clip

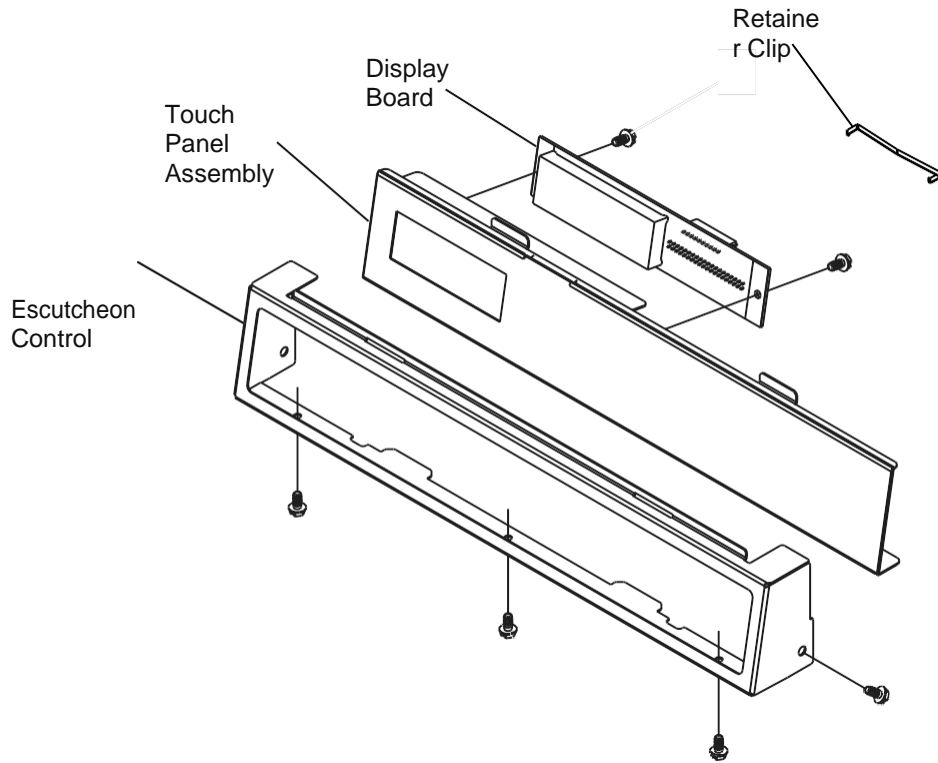

Main Control Board
2.5 Amp Fuse
Fan Motor
Fan Guard
40 pin Header Bracket

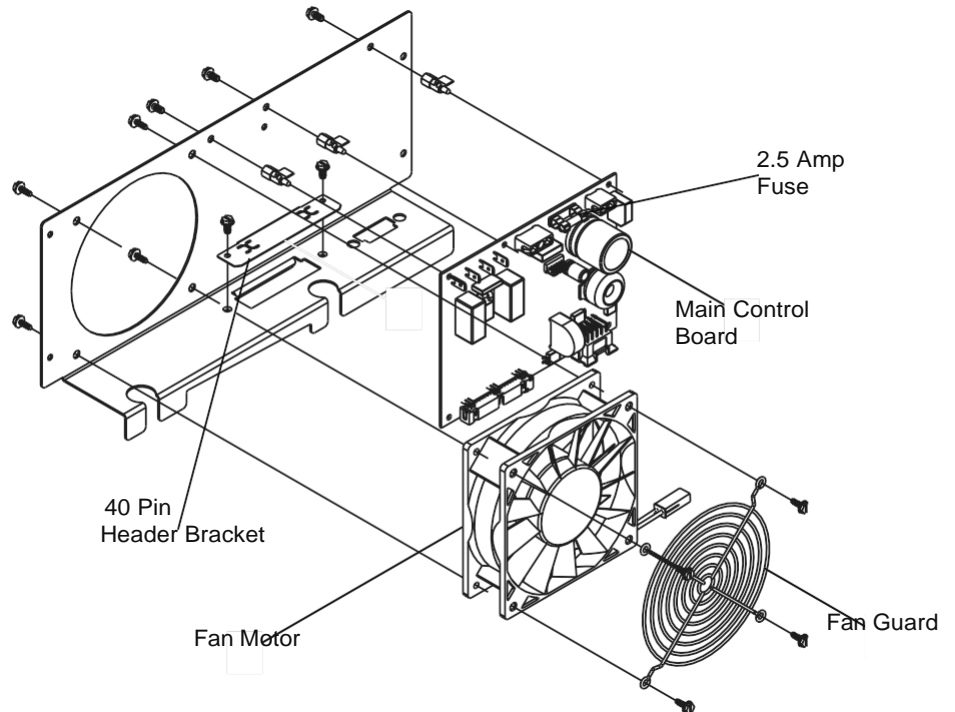

OVEN CONSTRUCTION-

Antenna
 Antenna Motor
 Interlock Switch
 Solenoid Assy

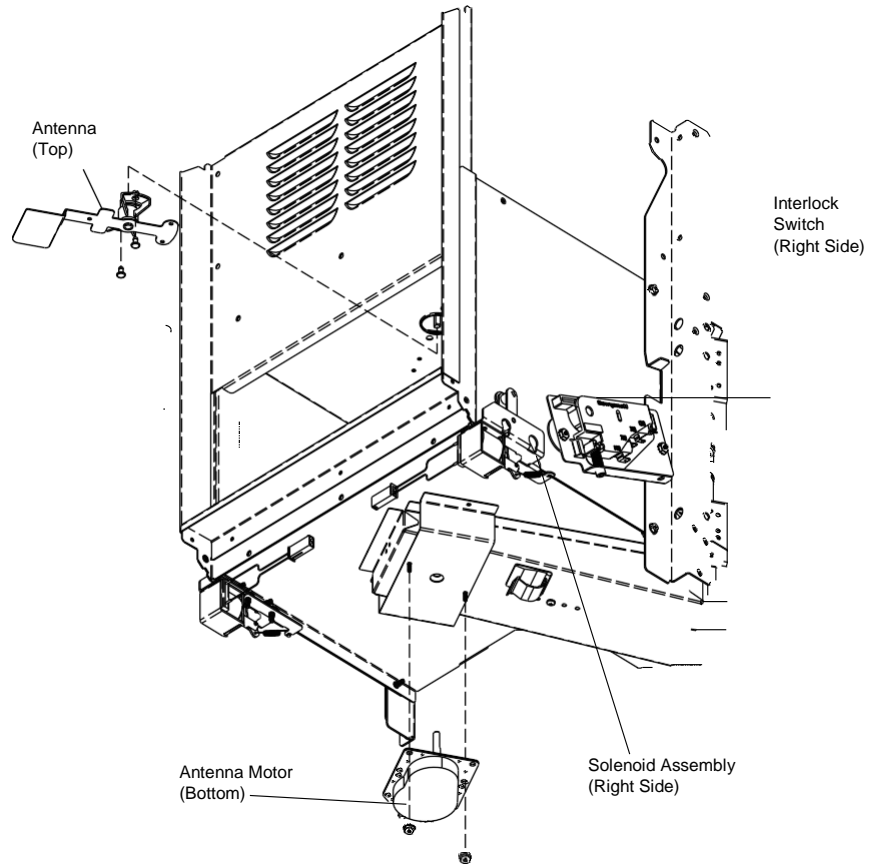

Diode
 Capacitor
 Magnetron
 Magnetron Gasket
 Magnetron TCO
 PC Board Harness

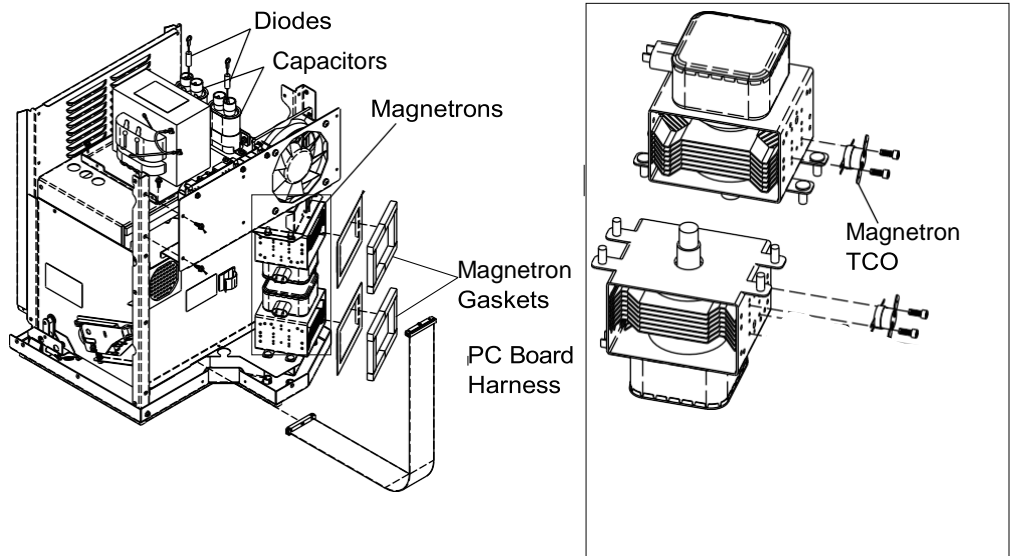

OVEN CONSTRUCTION-

- Antenna (Bottom)
- Antenna Shield
- Ceramic Tray
- Tray Support
- Glide Strip
- 20 Amp Fuse
- HV Transformer
- Triac 40A
- Control Transformer

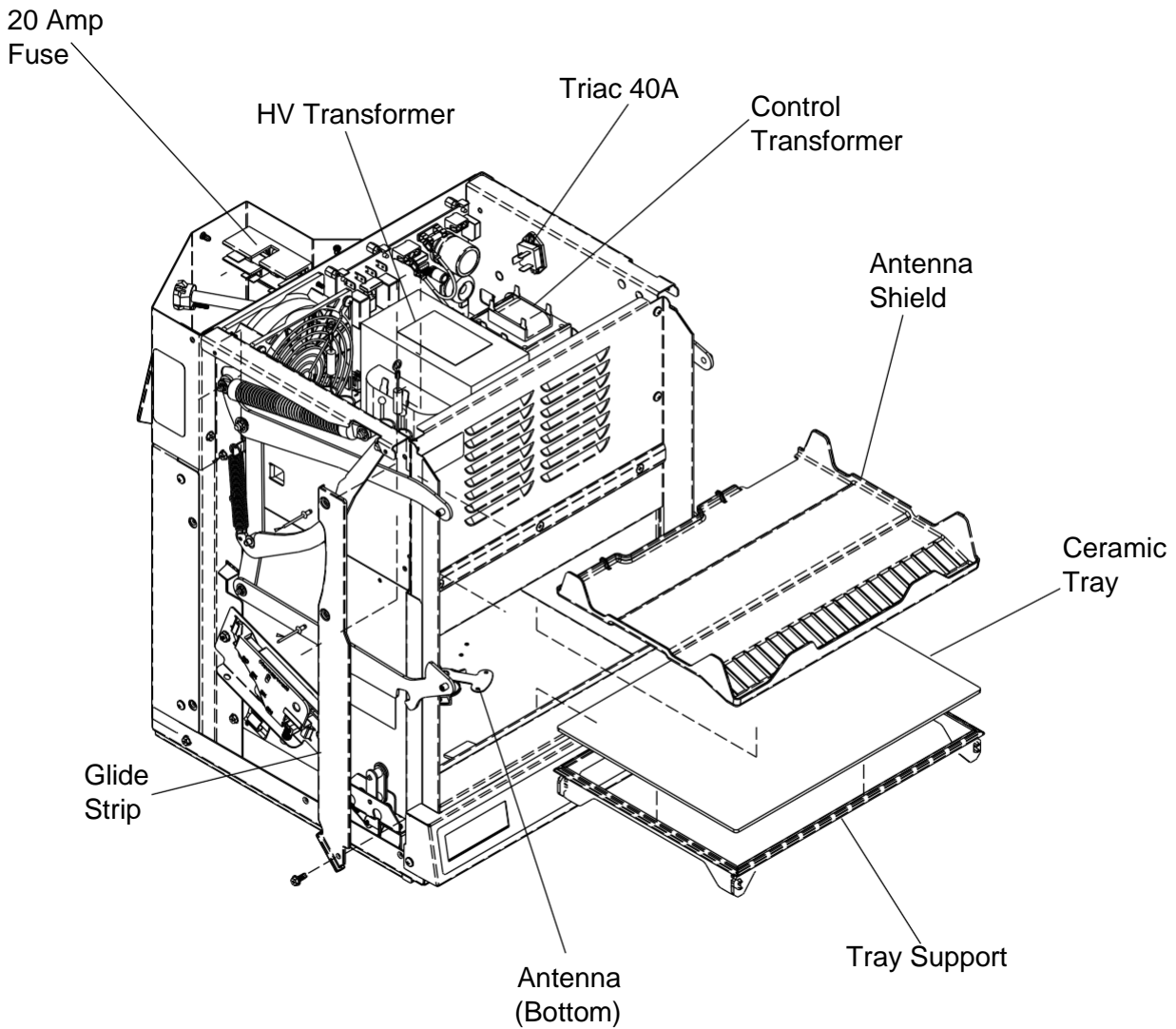

OVEN CONSTRUCTION-

- Lower Back Panel
- Cavity Exhaust Gasket
- Cavity Exhaust Fan Motor
- Cavity TCO
- Cavity Fan Hood

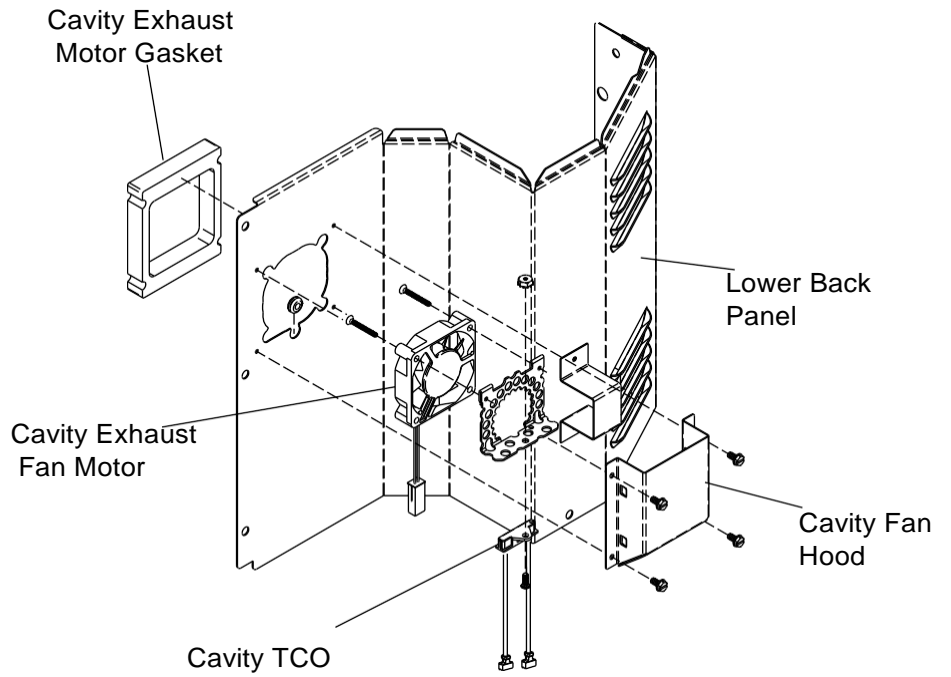

-
- Hinge Assembly
 - Hinge Spring

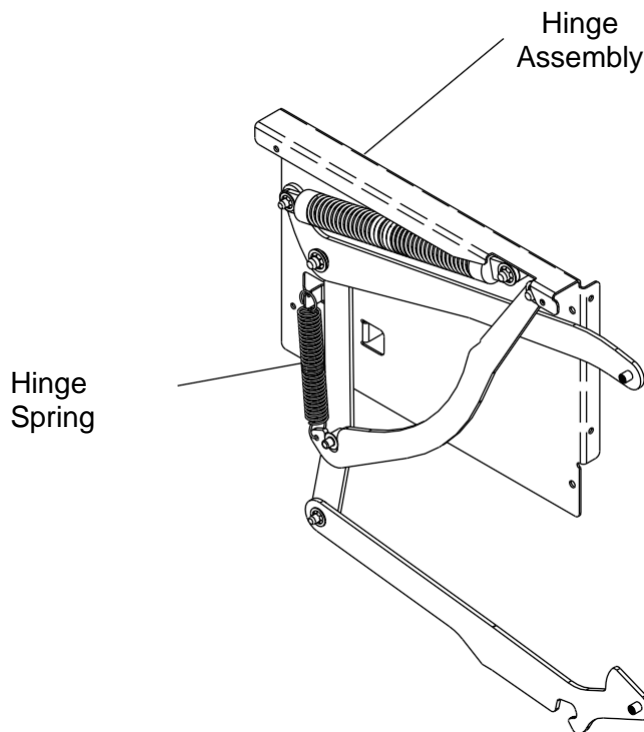

OVEN PERFORMANCE TEST

All Amana and Menumaster microwave oven power outputs are rated using the IEC705 standards. Using the IEC705 test method requires precision measurements and equipment that is not practical to be performed in the field. Using the test shown below will indicate if the oven performance is satisfactory.

Test equipment required:

- 1000 ml test container and thermometer.
- Digital watch / watch with a second hand for use on ovens with electromechanical timers.

Important Notes:

- Low line voltage will cause low temperature rise / power output.
- Ovens must be on a dedicated circuit, properly grounded, and polarized. Other equipment on the same circuit may cause a low temperature rise / power output.
- This test and results are not a true IEC705 test procedures and are only intended to provide servicers with an easy means of determining if the microwave oven cooking output is correct.

Procedure

1. Fill the test container to the 1000 ml line with cool tap water.

NOTE: Water temperature should be approximately 60°F / 16°C

2. Using the thermometer, stir water for five to ten seconds; measure, and record the temperature (T1).
3. Place test container of water in the center of oven cavity and close door.
4. Heat the water for a 33-second full power cycle.

NOTE: Burger King uses a similar test using a bowl and lid, heating time is 30 seconds.

NOTE: Use a digital watch or a watch with a second hand for ovens with electromechanical timers.

5. At end of the cycle, remove test container. Using the thermometer, stir water for five to ten seconds and record temperature (T2).
6. Subtract the starting water temperature (T1) from the ending water temperature (T2) to obtain the temperature rise (ΔT).
7. If the temperature rise (ΔT) meets or exceeds the minimum, the test is complete. If the temperature rise (ΔT) fails to meet the minimum temperature rise, test the line voltage to verify it is correct. Then repeat steps 1 - 6 making sure to change the water. If the temperature rise (ΔT) fails to meet the minimum temperature rise again the oven will require service.





Minimum Temperature Rise at Thirty (30) Seconds Run Time

ΔT (°F)	Cooking Power Output	ΔT (°F)	Cooking Power Output	ΔT (°C)	Cooking Power Output	ΔT (°C)	Cooking Power Output
10.....	1000	20.....	2000	5	1000	11	2000
11.....	1100	21.....	2100	5.5	1100	11.5	2100
12.....	1200	22.....	2200	6.5	1200	12	2200
14.....	1400	24.....	2400	7.5	1400	13	2400
17.....	1700	25.....	2500	9.5	1700	13.5	2500
18.....	1800	27.....	2700	10	1800	15	2700
19.....	1900	30.....	3000	10.5	1900	16.5	3000

COMPONENT TESTING PROCEDURES

⚠ WARNING

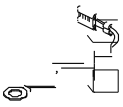
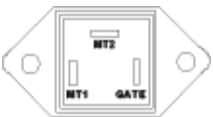
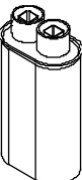
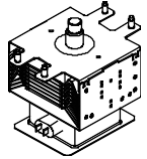
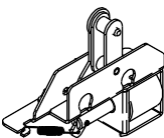



To avoid risk of electrical shock, personal injury or death; disconnect power to oven and discharge capacitor before servicing, unless testing requires power.

Illustration	Component	Testing	Results
	Magnetron TCO	Disconnect all wires from TCO. Measure resistance across terminals. Magnetron TCO.....	Closed at 257°F (125°C) and Opens at 300°F (149°C)
	Cavity TCO	Disconnect all wires from TCO. Measure resistance across terminals. Cavity TCO.....	Opens at 219°F (104°C)
	Diode	Discharge Capacitor Remove diode lead from capacitor and connect ohmmeter. Reverse leads for second test.	Infinite resistance should be measured in one direction and 50KΩ or less in the opposite direction. NOTE: Ohmmeter must contain a battery of 6 volts minimum.
	Triac	Resistance Check Disconnect wires to triac Measure resistance from: MT1 to MT2 MT1 to Gate MT2 to Gate All terminals to ground	Caution – Do not operate oven with wire to terminal MT2 removed. Infinite Approximately 60Ω Infinite Infinite
		Voltage Check Measure voltage from: MT1 to Gate MT1 to MT2	0.8 VAC when energized. 0 volts when gate energized or closed. Line volts when gate not energized or open.
	Capacitor	Discharge Capacitor Remove wires from capacitor terminals and connect ohmmeter, set on highest resistance scale to terminals. Also check between each terminal and capacitor case.	Between Terminals: Meter should momentarily deflect towards zero then return to over 5 MΩ. If no deflection occurs, or if continuous deflection occurs, replace capacitor. Terminal to Case: Infinite resistance
	Magnetron	Discharge Capacitor Remove wires from magnetron and connect ohmmeter to terminals. Also check between each terminal and ground.	Between Terminals: Less than 1 Ω Each terminal to ground measures Infinite resistance. Note: This test is not conclusive. If oven does not heat and all other components test good replace the magnetron and retest.
	Solenoid (Left, Right)	Disconnect connector from solenoid Measure resistance across coil.....	Approximately 6-11 Ω
	Stirrer motor	Remove all wires from motor. Measure resistance across terminals	Approximately 12K Ω

COMPONENT TESTING PROCEDURES

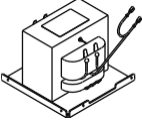
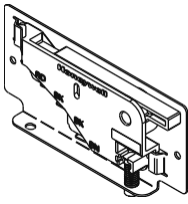
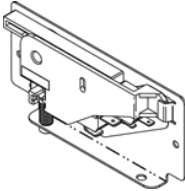
⚠ WARNING

To avoid risk of electrical shock, personal injury or death; disconnect power to oven and discharge capacitor before servicing, unless testing requires power.

Illustration	Component	Testing	Results
	Transformer, HV	Discharge Capacitor Remove all wires from terminals. Measure resistance from: 230 to COM..... 208 to COM..... 230 to Ground 208 to Ground----- Terminal 5 to 6----- Terminal 7 to 8----- Terminal 4 to Ground-----	Less than 1 Ω Less than 1 Ω Infinite Infinite Less than 1 Ω Less than 1 Ω Approximately 27 Ω
	Main board	See Main Board page 5	
	Left interlock switch assembly (Mechanical)	Disconnect wires to switch. With door open measure resistance from: Monitor – Terminals Rd- Bk..... Primary – Terminals Bk - Brn With door closed measure resistance from: Monitor – Terminals RD - BK Primary – Terminals BK - BN	Indicates continuity Infinite Ω Infinite Ω Indicates continuity
	Right interlock switch assembly (Mechanical)	Disconnect wires to switch. With door open measure resistance from: Monitor – Terminals RD- BK Secondary – Terminals GY -RD..... With door closed measure resistance from: Monitor – Terminals RD - BK Secondary – Terminals GY - RD.....	Indicates continuity Infinite Ω Infinite Ω Indicates continuity
	Transformer, control	(1) BU to (5) BR ----- (6) YL to (10) WH-----	Approximately 40 Ω or Line Voltage Approximately 1 Ω or 28 VAC
	Fan, cooling	Disconnect connector from fan. Measure voltage at incoming leads	Approximately 24VDC
	Fan, exhaust	Disconnect connector from fan. Measure voltage at incoming leads	Approximately 24VDC

COMPONENT TESTING PROCEDURES

WARNING

To avoid risk of electrical shock, personal injury or death; disconnect power to oven and discharge capacitor before servicing, unless testing requires power.

Main. Board

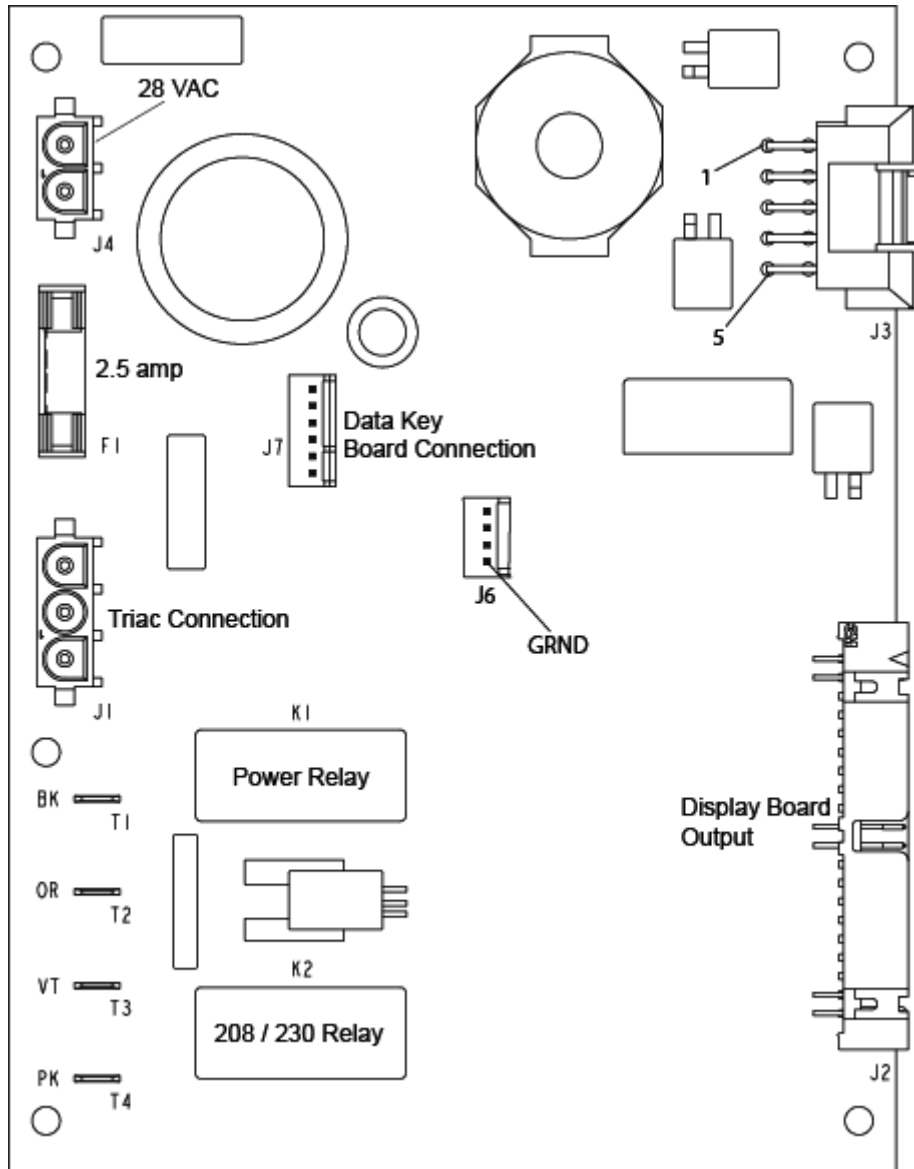

Function	Test Set-Up	Meter Setting	Probe Placement	Results
Input to main board Left, Right Switch Assembly	Main Board (Door Closed)	Volts	Main Board T-1 (Black wire) Triac (Red wire)	Line voltage
J4 Input from Control Transformer	Main Board	Volts	J4-1 & J4-2	28 VAC

COMPONENT TESTING PROCEDURES



WARNING

To avoid risk of electrical shock, personal injury or death; disconnect power to oven and discharge capacitor before servicing, unless testing requires power.

Function	Test Set-Up	Meter Setting	Probe Placement	Results
2.5 amp fuse Note: If Fuse is blown unit is non operational Fuse is field replaceable.	Remove fuse from holder	Ohms	Measure resistance across fuse	Continuity
208/230 Volt Relay 230 Volt Output	T4 to Blue wire at J1 Triac connection	Volts	T4 to Blue wire at Triac Connection	230 volts when 230 volts line voltage present
208/230 Volt Relay 208 Volt Output	T3 to Blue wire at J1 Triac connection	Volts	T3 to Blue wire at Triac Connection	208 volts when 208 volts line voltage present
J1 Triac Output Connection	Orange wire to Red wire	Volts	Orange wire at Traic Connection. Red wire at Triac Connection	0.8 VAC when Triac energized
Power Relay	T3 to Blue wire at J1 Triac connection	Volts	T3 to Blue wire at Triac Connection	208 volts when 208 volts line voltage present
	T4 to Blue wire at J1 Triac Connection	Volts	T4 to Blue wire at Triac Connection	230 volts when 230 volts line voltage present

Illustration	Component	Test	Pad	Results																														
	Keypad	Removal of touch panel is required to perform test. Continuity is indicated as 100 Ω and below. 		<table border="1"> <thead> <tr> <th>Trace</th> <th>Measurement</th> </tr> </thead> <tbody> <tr><td>1</td><td>8 & 10</td></tr> <tr><td>2</td><td>7 & 10</td></tr> <tr><td>3</td><td>6 & 10</td></tr> <tr><td>4</td><td>5 & 10</td></tr> <tr><td>5</td><td>4 & 10</td></tr> <tr><td>6</td><td>3 & 10</td></tr> <tr><td>7</td><td>8 & 9</td></tr> <tr><td>8</td><td>7 & 9</td></tr> <tr><td>9</td><td>6 & 9</td></tr> <tr><td>0</td><td>5 & 9</td></tr> <tr><td>Start</td><td>4 & 9</td></tr> <tr><td>Stop</td><td>4 & 8</td></tr> <tr><td>Power Level</td><td>5 & 8</td></tr> <tr><td>Time Entry</td><td>7 & 8</td></tr> </tbody> </table>	Trace	Measurement	1	8 & 10	2	7 & 10	3	6 & 10	4	5 & 10	5	4 & 10	6	3 & 10	7	8 & 9	8	7 & 9	9	6 & 9	0	5 & 9	Start	4 & 9	Stop	4 & 8	Power Level	5 & 8	Time Entry	7 & 8
			Trace	Measurement																														
			1	8 & 10																														
			2	7 & 10																														
			3	6 & 10																														
			4	5 & 10																														
			5	4 & 10																														
			6	3 & 10																														
			7	8 & 9																														
			8	7 & 9																														
			9	6 & 9																														
			0	5 & 9																														
			Start	4 & 9																														
Stop	4 & 8																																	
Power Level	5 & 8																																	
Time Entry	7 & 8																																	

TROUBLESHOOTING CHART

Initial Power-Up (Door Open)

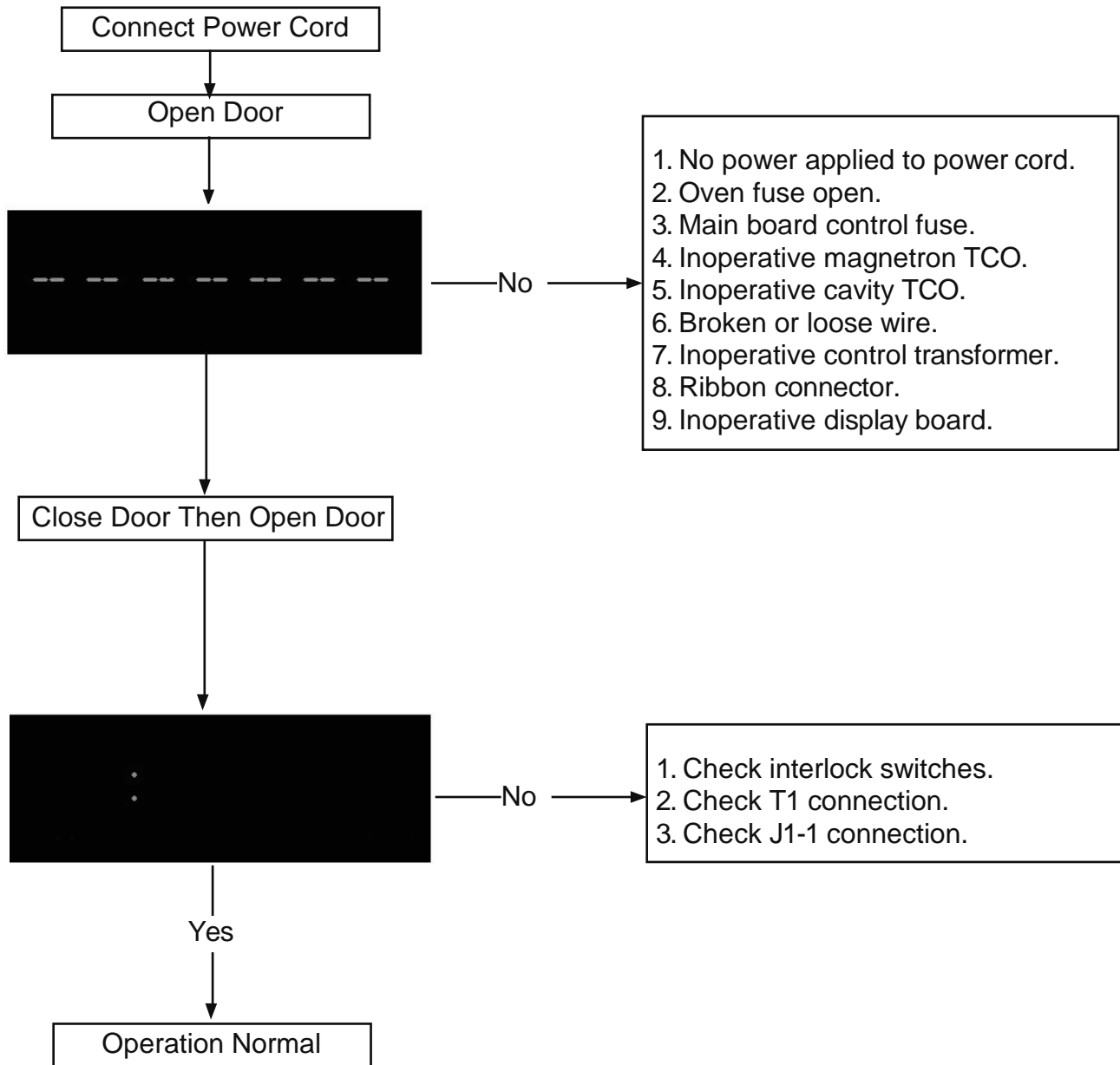

TROUBLESHOOTING CHART

Cook Condition

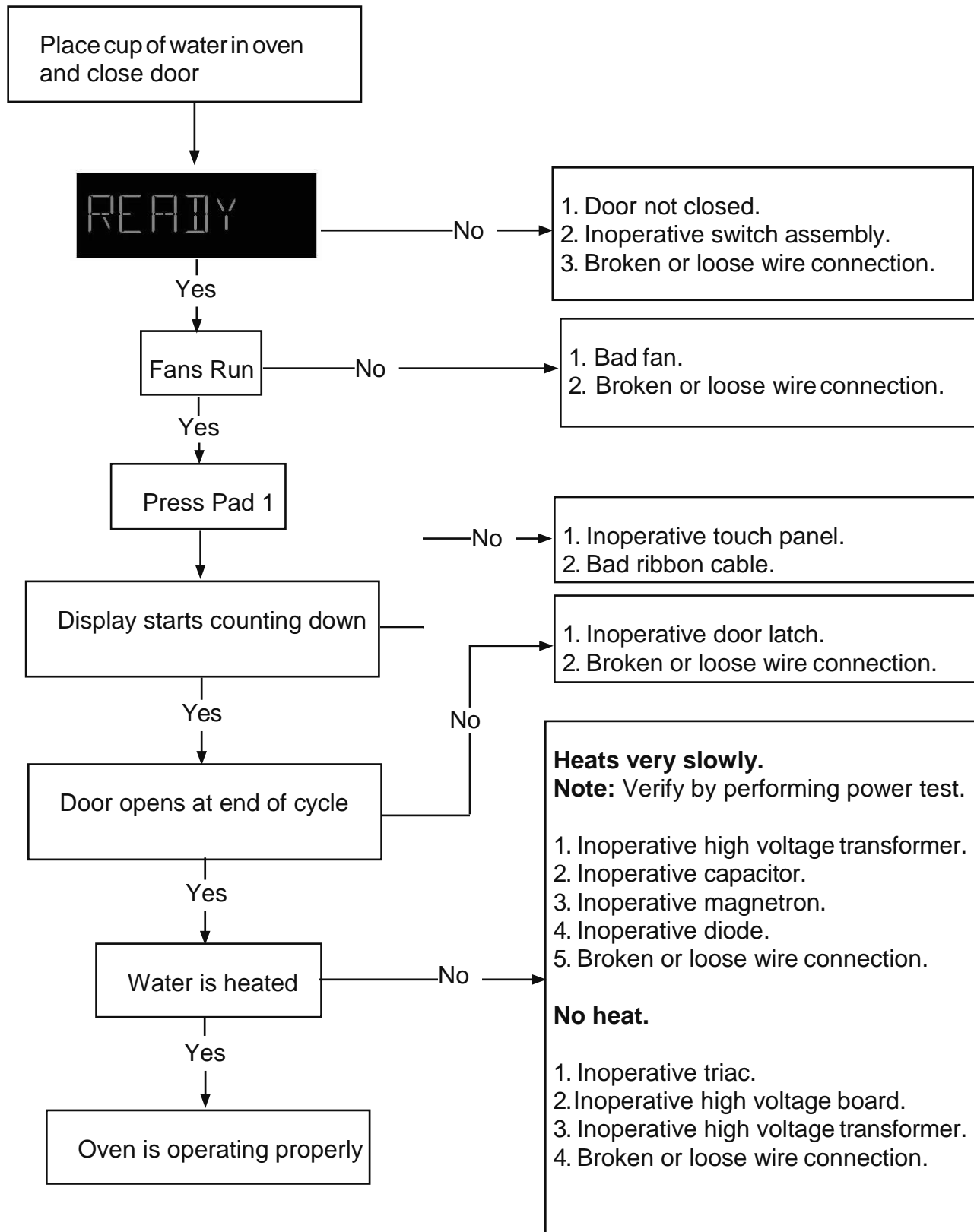

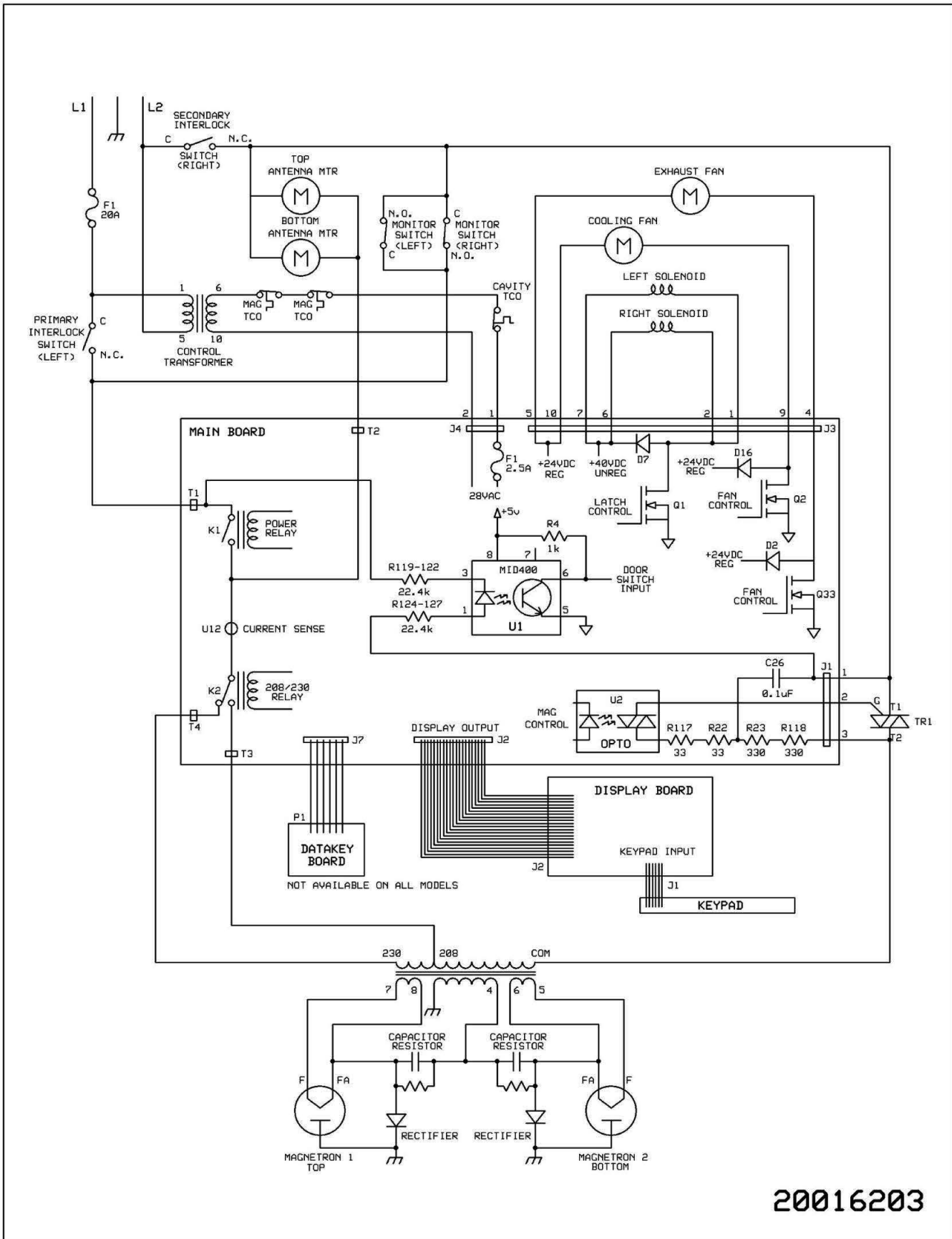

20016203

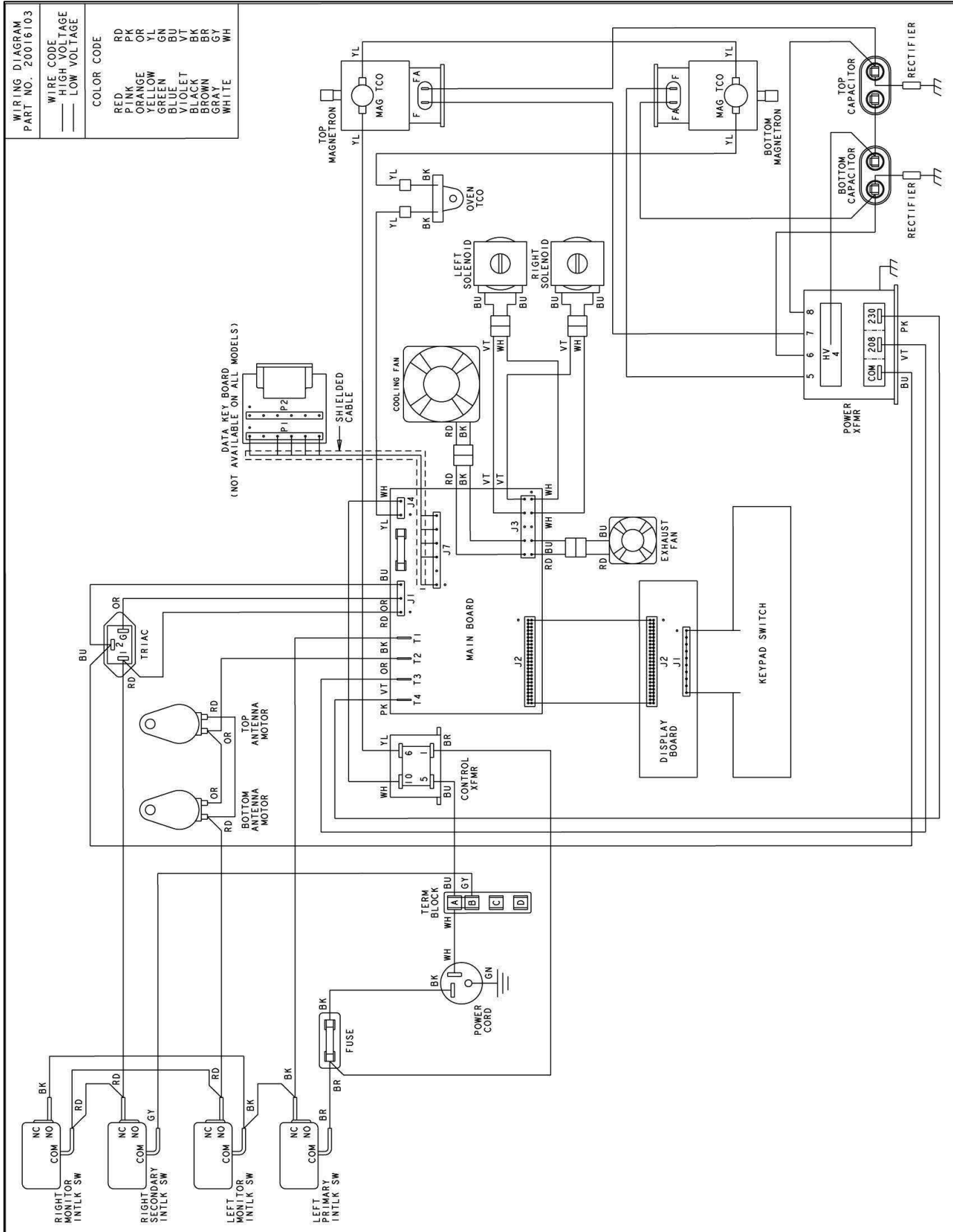

Appendix A

Quick Start Reference

Refer to Product Safety Manual for Safety Statements

So...how do I use it?

Preprogrammed Pads

To cook food using preprogrammed cooking sequences.

1. Place food in oven. Close door.
2. Press desired pad.
3. Oven begins to cook.
4. At end of cooking cycle oven door opens

Manual Operation

To cook food using a specific entered time and power level.

1. Place food in oven. Close door.
2. Press TIME ENTRY pad and enter cooking time.
3. Press POWER LEVEL pad to program microwave power level if less than 100% is desired.
 - For a lower microwave power, press pads 1 (for 10%), through 9 (for 90%), or 0 for no microwave energy.
4. Press START pad.
5. At end of cooking cycle oven door opens.

Programming Items

1. Press and hold pad 1 for approximately 5 seconds with the door open.
2. Press pad to be reprogrammed.
3. Enter cooking time by using the number pads.
4. Press POWER LEVEL pad to program microwave power level if less than 100% is desired.
 - For a lower microwave power, press pads 1 (for 10%), through 9 (for 90%), or 0 for no microwave energy.

NOTE: Press POWER LEVEL pad twice to return to 100% microwave power.

5. Press TIME ENTRY pad to add up to three additional cooking stages.
 - Total cooking time cannot exceed 5 minutes.
 - Enter cook time and power level as in steps 4 and 5.
6. Press START pad to set new programming changes to the pad.

NOTE: To discard changes, press STOP pad or close oven door.

Factory Settings

Pad	Seconds
1	5
2	10
3	15
4	20
5	25
6	30
7	35
8	40
9	45
0	60

Installation

- Do not install oven next to or above source of heat, such as pizza oven or deep fat fryer. This could cause microwave oven to operate improperly and could shorten life of electrical parts.
- Do not block or obstruct oven air inlet above door.
- Install oven on level countertop surface.
- Not recommended for built-in installations.
- Outlet should be located so that plug is accessible when oven is in place.
- A safety strap is attached to the side of the oven. This is to be used to secure two ovens together (back to back) on a shelf.

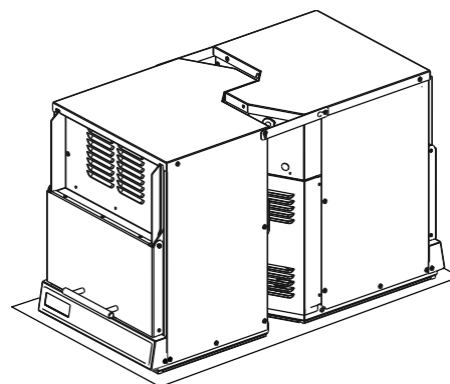

Quick Start Reference

For Enclosed Installation

A—For North America (UL/CSA) models, allow at least 2" (5.1cm) of clearance around top of oven. For International (50Hz) models,

allow at least 7 " (17.78 cm) of clearance around top. Proper air flow around oven cools electrical components. With restricted air flow, oven may not operate properly and life of electrical parts is reduced.

B—Allow at least 1" (2.54 cm) on sides of oven.

C—Allow at least 1 1/4" (3.18 cm) between air discharge on back of oven and back wall. Note: Back to back installation allows correct clearance.

Oven Clearances

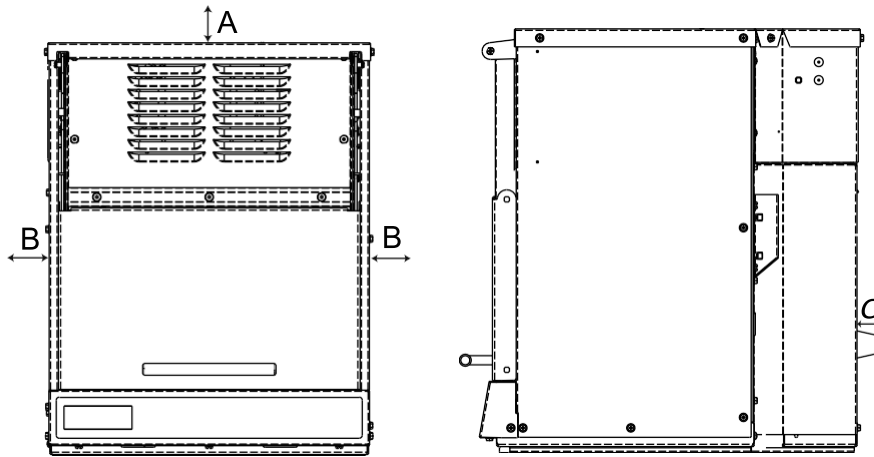

Troubleshooting Tips

If the door does not open after a cooking cycle. Press the stop button. If door still does not open, press stop again. If door still remains closed, gently pull door forward to open manually. If this continues to be an issue, please contact service.

- If door does not latch, call service.
- Should "CALL SERVICE" appear in the display unplug the oven for one minute then plug oven in. If "CALL SERVICE" reappears call for service.
- Door slow to open, clean glide strips.

Quick Start Reference

Care and Cleaning

Clean interior and exterior of microwave oven with mild detergent and damp soft sponge or cloth. Wring cloth or sponge to remove excess water before wiping equipment.

Splatter Shield (Clean Monthly)

1. Unplug the oven.
2. Place fingers behind the shield, pull forward and then down. Do not bend antenna.
3. Clean soil from shield with damp cloth or clean with mild detergent and water.

Note: Do not run oven without splatter shield.

Interior Door (Clean Daily)

1. To clean interior door, gently pull out on door until door opens at a 90-degree angle.



2. Wipe the underside of door and inside door arms with a damp cloth. Wipe dry.



Glide Strips (Clean Monthly)

1. Unplug the oven.
2. Clean in between door arms and side of cavity with a cloth (**Do not** use paper towels) on the end of a non metallic spatula with mild detergent or degreaser, cleaning the glide strips on both sides of the cavity.

3. Place door back in ready position by gently pushing downward.

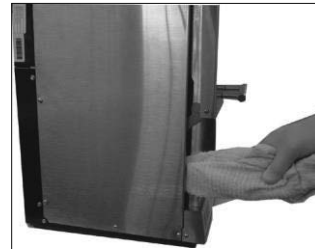

Important:

- Do not use abrasive cleaners or cleaners containing ammonia or citrus.
- Never pour water into microwave oven bottom.
- Do not use water pressure type cleaning systems.

Changing user options

Options such as single or double pad programming and beep volume can be changed to suit individual preferences.



To change options:

1. Press and hold pad 2 for approximately 5 seconds with door open.
2. Option appears in display.
 - Oven is now in options mode.
3. Press number pad that controls option to be changed.
 - See table below for options.
 - Current option will display.
4. Press number pad again to change the option.
 - Each time pad is pressed, option will change.
 - Match code displayed with code for desired option.
 - Changes take affect after START pad is pressed.
 - To change additional options, repeat steps 3 and 4.
5. Press START pad to return to Options. Open and close oven door or press STOP to exit.

Numbered Pads	Display	Options (Factory Settings in Bold)
1 End of Cycle Beep	OP:10 OP:11 OP:12 OP:13 OP:14 OP:15 OP:16	3 second continuous beep. 5 second beeps once. Continuous beep until done disappears. Repeating 5 beeps bursts until door is opened. Continuous beep until stop pad is pressed or door is cycled. Repeating 5 beeps burst until stop pad is pressed or door is cycled. No beep.
2 Speaker Volume	OP:20 OP:21 OP:22 OP:23	Eliminates beep. Sets volume to low. Sets volume to medium. Sets volume to high.
3 Key Beep	OP:30 OP:31	Prevents beep when pad is pressed. Allows beep when pad is pressed.
4 Keyboard Enable Window	OP:40 OP:41 OP:42 OP:43	15 seconds after oven door is closed, keyboard disabled. 30 seconds after oven door is closed, keyboard disabled. 1 minute after oven door is closed, keyboard disabled. 2 minutes after oven door is closed, keyboard disabled.
5 End of Cycle Message Time	OP:50 OP:51 OP:52 OP:53 OP:55 OP:56 OP:57 OP:58 OP:59	10 seconds 20 seconds 30 seconds 40 seconds 60 seconds 1 minute 10 seconds 1 minute 20 seconds 1 minute 30 seconds 1 minute 40 seconds
6 Stop during cooking cycle	OP:60 OP:61 OP:62	Pressing stop clears information, opens door. Pressing stop pauses oven with door closed. Pressing stop pauses oven with door open.
7 Maximum Cook Time Entry	OP:70 OP:71	Allows 5 minutes of heating time. Allows 10 minutes of heating time.
8 Time Entry	OP:80 OP:81	Allows use of preprogrammed pads only. Allows use of manual time entry and preprogrammed pads.
9 Double Digit Operation	OP:90 OP:91	Allows 10 (0-9) preprogrammed pads. Allows 100 (00-99) preprogrammed pads.
0 ON-THE-FLY Cooking	OP:00 OP:01	Disables ON-THE-FLY Cooking. Allows ON-THE-FLY Cooking.