

Service Training Manual

RCS / MCS Models



RCS / MCS - 60 Hz
August 2012
16400020

© / ™ © 2012 Amana. All rights reserved. Brand used under license.

Table of Contents

Important Safety Information.....	3-6
Installation.....	7
Specifications.....	8
Quick Start Reference Guide (Electronic Mechanical Dial).....	9
Quick Start Reference Guide (Electronic Control).....	10-11
Components Location.....	12-16
Performance Testing Procedures.....	17
Component Testing Procedures	18-19
Troubleshooting.....	20-21
Schematic / Wiring Diagrams.....	22

Important Information

Important Notices for Servicers and Consumers

ACP will not be responsible for personal injury or property damage from improper service procedures. Pride and workmanship go into every product to provide our customers with quality products. It is possible, however, that during its lifetime a product may require service. Products should be serviced only by a qualified service technician who is familiar with the safety procedures required in the repair and who is equipped with the proper tools, parts, testing instruments and the appropriate service information. IT IS THE TECHNICIAN'S RESPONSIBILITY TO REVIEW ALL APPROPRIATE SERVICE INFORMATION BEFORE BEGINNING REPAIRS.

 WARNING
To avoid risk of severe personal injury or death, disconnect power before working/servicing on appliance to avoid electrical shock.

To locate an authorized servicer please contact:

ComServ Support Center



Web Site
WWW.ACPSOLUTIONS.COM

Telephone Number
..... 1-866-426-2621 or 319-368-8195

E-Mail: commercialservice@acpsolutions.com

Recognize Safety Symbols, Words, and Labels

 DANGER

DANGER— Immediate hazards which WILL result in severe personal injury or death.

 WARNING
--

WARNING— Hazards or unsafe practices which COULD result in severe personal injury or death.

 CAUTION
--

CAUTION— Hazards or unsafe practices which COULD result in minor personal injury, product or property damage.

Important Safety Information



WARNING

Read the following information to avoid possible exposure to microwave radiation:

The basic design of the Microwave Oven makes it an inherently safe device to both use and service.

However, there are some precautions which should be followed when servicing the microwave to maintain this safety. These are as follows:

1. Always operate the unit from an adequately grounded outlet. Do not operate on a two-wire extension cord.
2. Before servicing the unit (if unit is operable) perform the microwave leakage test.
3. The oven should never be operated if the door does not fit properly against the seal, the hinges or hinge bearings are damaged or broken; the choke is damaged, (pieces missing, etc.); or any other visible damage can be noted. Check the choke area to ensure that this area is clean and free of all foreign matter.
4. If the oven operates with the door open and produces microwave energy, take the following steps:
 - A. Tell the user not to operate the oven.
 - B. Contact ACP ComServ immediately.
5. Always have the oven disconnected when the outer case is removed except when making the "live" tests called for in the Service Manual. Do not reach into the equipment area while the unit is energized. Make all connections for the test and check them for tightness before plugging the cord into the outlet.
6. Always ground the capacitors on the magnetron filter box with an insulated-handle screwdriver before working in the high voltage area of the equipment compartment. Some types of failures will leave a charge in these capacitors and the discharge could cause a reflex action which could make you injure yourself.
7. Always remember that in the area of the transformer there is HIGH VOLTAGE. When the unit is operating keep this area clear and free of anything which could possibly cause an arc or ground, etc.
8. Do not for any reason defeat the interlock switches there is not valid reason for this action at any time; nor will it be condoned by ACP.
9. IMPORTANT: Before returning a unit to a customer, be sure to check for proper switch interlock action.
10. The Microwave Oven should never be operated with any components removed and/or bypassed or when any of the safety interlocks are found to be defective, or when any of the seal surfaces are defective, missing, or damaged.
11. All microwave ovens meet all requirements of the radiation control for Health and Safety Act of 1968. Due to measurement uncertainties, the maximum leakage for the field will be $4\text{mw}/\text{cm}^2$.
12. To ensure that the unit does not emit excessive microwave leakage and to meet the Department of Health and Human Services guidelines, check the oven for microwave leakage using a microwave oven leakage meter that complies with US Government CDRH / FDA / DHHS requirements and or any other local government requirements. The maximum leakage level allowed by ACP is $4\text{mw}/\text{cm}^2$.
13. If servicer encounters an emission reading over $4\text{mw}/\text{cm}^2$, the servicer is to cease repair and contact the ACP ComServ Department immediately for further direction. ACP will contact the proper Government Agency upon verification of the test results.



IMPORTANT SAFETY INSTRUCTIONS

This is the safety alert symbol. It is used to alert you to potential personal injury hazards. Obey all safety messages that follow this symbol to avoid possible injury or death.



WARNING

When using electrical equipment, basic safety precautions should be followed to reduce the risk of burns, electrical shock, fire, or injury to persons including the following.

1. READ all instructions before using equipment.
2. READ AND FOLLOW the specific “PRECAUTIONS TO AVOID POSSIBLE EXPOSURE TO EXCESSIVE MICROWAVE ENERGY” on this page.
3. This equipment **MUST BE GROUNDED**. Connect only to properly GROUNDED outlet. See “GROUNDING / EARTHING INSTRUCTIONS” on page 5.
4. Install or locate this equipment **ONLY** in accordance with the installation instructions in this manual.
5. Some products such as whole eggs and sealed containers—for example, closed glass jars—are able to explode and **SHOULD NOT** be HEATED in this oven.
6. Use this equipment **ONLY** for its intended use as described in this manual. Do not use corrosive chemicals or vapors in this equipment. This type of oven is specifically designed to heat, cook, or dry food. It is not designed for industrial or laboratory use.
7. As with any equipment, **CLOSE SUPERVISION** is necessary when used by **CHILDREN**.
8. See door cleaning instructions on page A-4 of this owners manual.
9. **DO NOT** heat baby bottles in oven.
10. Baby food jars shall be open when heated and contents stirred or shaken before consumption, in order to avoid burns.
11. **DO NOT** operate this equipment if it has a damaged cord or plug, if it is not working properly, or if it has been damaged or dropped.
12. This equipment, including power cord, must be serviced **ONLY** by qualified service personnel. Special tools are required to service equipment. Contact nearest authorized service facility for examination, repair, or adjustment.
13. **DO NOT** cover or block louvers or other openings on equipment.
14. **DO NOT** store this equipment outdoors. **DO NOT** use this product near water – for example, near a kitchen sink, in a wet basement, a swimming pool, or a similar location.
15. **DO NOT** immerse cord or plug in water.
16. Keep cord **AWAY** from **HEATED** surfaces.
17. **DO NOT** let cord hang over edge of table or counter.
18. For commercial use only.

PRECAUTIONS TO AVOID POSSIBLE EXPOSURE TO EXCESSIVE MICROWAVE ENERGY

- A. **DO NOT** attempt to operate this oven with the door open since open door operation can result in harmful exposure to microwave energy. It is important not to defeat or tamper with the safety interlocks.
- B. **DO NOT** place any object between the oven front face and the door to allow soil or cleaner residue to accumulate on sealing surfaces.
- C. **DO NOT** operate the oven if it is damaged. It is particularly important that the oven door close properly and that there is no damage to the:
 1. door (bent)
 2. hinges and latches (broken or loosened)
 3. door seals and sealing surfaces.
- D. The oven should not be adjusted or repaired by anyone except properly qualified service personnel.

SAVE THESE INSTRUCTIONS

IMPORTANT SAFETY INSTRUCTIONS



WARNING

To avoid risk of fire in the oven cavity:

- a. DO NOT overcook food. Carefully attend oven when paper, plastic, or other combustible materials are placed inside the oven to facilitate cooking.
- b. Remove wire twist-ties from paper or plastic bags before placing bag in oven.
- c. If materials inside the oven ignite, keep oven door CLOSED, turn oven off and disconnect the power cord, or shut off power at the fuse or circuit breaker panel.
- d. DO NOT use the cavity for storage. DO NOT leave paper products, cooking utensils, or food in the cavity when not in use.



WARNING

Liquids such as water, coffee, or tea are able to be overheated beyond the boiling point without appearing to be boiling due to surface tension of the liquid. Visible bubbling or boiling when the container is removed from the microwave oven is not always present. THIS COULD RESULT IN VERY HOT LIQUIDS SUDDENLY BOILING OVER WHEN A SPOON OR OTHER UTENSIL IS INSERTED INTO THE LIQUID. To reduce the risk of injury to persons:

- i) Do not overheat the liquid.
- ii) Stir the liquid both before and halfway through heating it.
- iii) Do not use straight-sided containers with narrow necks.
- iv) After heating, allow the container to stand in the microwave oven for a short time before removing the container.
- v) Use extreme care when inserting a spoon or other utensil into the container.



CAUTION

To avoid personal injury or property damage, observe the following:

1. Do not deep fat fry in oven. Fat could overheat and be hazardous to handle.
2. Do not cook or reheat eggs in shell or with an unbroken yolk using microwave energy. Pressure may build up and erupt. Pierce yolk with fork or knife before cooking.
3. Pierce skin of potatoes, tomatoes, and similar foods before cooking with microwave energy. When skin is pierced, steam escapes evenly.
4. Do not operate equipment without load or food in oven cavity.
5. Microwave popcorn should not be popped in oven.
6. Do not use regular cooking thermometers in oven. Most cooking thermometers contain mercury and may cause an electrical arc, malfunction, or damage to oven.
7. Do not use metal utensils in oven.
8. Do not use aluminum foil in oven
9. Never use paper, plastic, or other combustible materials that are not intended for cooking.
10. When cooking with paper, plastic, or other combustible materials, follow manufacturer's recommendations on product use.
11. Do not use paper towels which contain nylon or other synthetic fibers. Heated synthetics could melt and cause paper to ignite.
12. Do not heat sealed containers or plastic bags in oven. Food or liquid could expand quickly and cause container or bag to break. Pierce or open container or bag before heating.
13. To avoid pacemaker malfunction, consult physician or pacemaker manufacturer about effects of microwave energy on pacemaker.
14. An authorized servicer MUST inspect equipment annually. Record all inspections and repairs for future use.

SAVE THESE INSTRUCTIONS

Installation

Unpacking Oven

- Inspect oven for damage such as dents in door or dents inside oven cavity.
- Report any dents or breakage to source of purchase immediately. Do not attempt to use oven if damaged.
- Remove all materials from oven interior.
- If oven has been stored in extremely cold area, wait a few hours before connecting power.

Radio Interference

Microwave operation may cause interference to radio, television, or similar a oven. Reduce or eliminate interference by doing the following:

- Clean door and sealing surfaces of oven according to instructions in “Care and Cleaning” section.
- Place radio, television, etc. as far as possible from oven.
- Use a properly installed antenna on radio, television, etc. to obtain stronger signal reception.

⚠️ WARNING

Excessive Weight Hazard

**Use two or more people to move and install oven.
Failure to do so can result in back or other injury.**

Oven Placement

- Do not install oven next to or above source of heat, such as pizza oven or deep fat fryer. This could cause microwave oven to operate improperly and could shorten life of electrical parts.
- Do not block or obstruct oven filter. Allow access for cleaning.
- Install oven on level countertop surface.

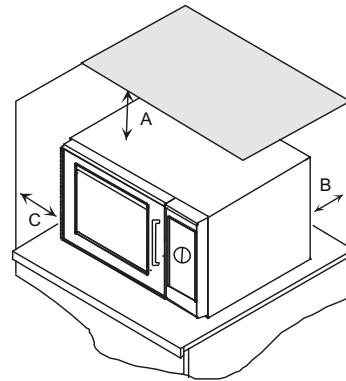

Oven Clearances

- A—For North American (UL/CSA) models, allow at least 2" (5.1 cm) of clearance around top of oven. For International (50 Hz) models, allow at least 12" (30 cm) of clearance around top of oven. Proper air flow around oven cools electrical components. With restricted air flow, oven may not operate properly and life of electrical parts is reduced.
- B—Allow at least 2" (5.1 cm) between air discharge on back of oven and back wall.
- C—Allow at least 2" (5.1 cm) of clearance around sides of oven.

Specifications

Models	RCS10DSE, MCS10DSE, RCS10TS, MCS10TS
Power Source	
Voltage AC	120V
Amperage	15 A
Frequency	60 Hz
Single Phase, 3 wire grounded	X
Plug Configuration / Cord	NEMA 5-20
Power Output	
Nominal microwave energy (IEC705)	1000 W
Minimum temperature rise	10°F / 5°C
Operating Frequency	2450 MHz
Power Consumption	
Cook Condition Microwave	1550 W
Dimensions	
Cabinet	
Width	22" (560)
Height	13 ¾" (349)
Depth	19" (482)
Cavity Dimensions	
Width	14 ½" (368)
Height	8 ½" (216)
Depth	15" (381)
Weight	
Crated	47 lbs. (21.3 kg.)
Uncrated	41 lbs. (18.6 kg.)

Quick Start Reference Guide (Electronic / Mechanical Dial)

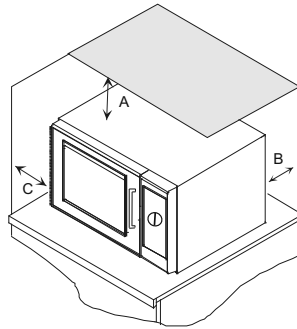
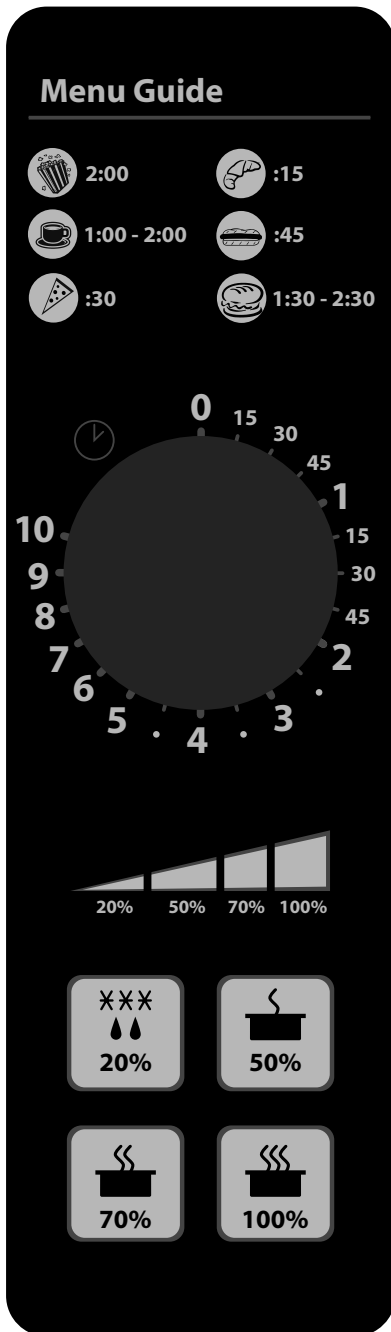

Oven Wall Clearances

A—For North American (UL/CSA) models, allow at least 2" (5.1 cm) of clearance around top of oven. For International (50 Hz) models, allow at least 12" (30 cm) of clearance around top of oven. Proper air flow around oven cools electrical components. With restricted air flow, oven may not operate properly and life of electrical parts is reduced.

B—Allow at least 2" (5.1 cm) between air discharge on back of oven and back wall.

C—Allow at least 2" (5.1 cm) of clearance around sides of oven.

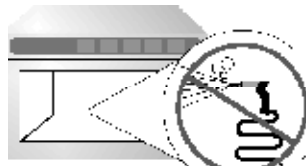

DO NOT power spray

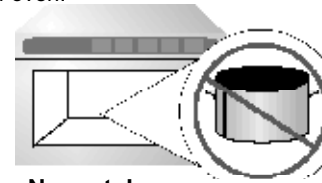

No metal pans

So...how do I use it? (Electronic / Mechanical Dial)

Heating

1. Open oven door, place food in oven, and close oven door.
2. Select desired power level or use default 100%.
 2. Turn time entry knob clockwise to desired time.
 - Cooking time can be set up to 10 minutes.
 - Oven begins operation and time counts down.
3. When cooking time has elapsed, microwave energy stops and oven signal sounds.

Interrupting Operation

Open oven door to interrupt operation or turn time entry knob counterclockwise to "0".

To resume microwave oven operation, close door, select power level pad, and turn knob.

Changing Time and Canceling Mistakes

Heating time and power level can be changed at any time while the oven is operating. Press power level pad or turn knob to desired new setting. To set cooking time to zero, turn knob counterclockwise to "0" or cycle door open and closed.

Changing Timer Option

Timer resetting to zero can be set at any time to pause current cook time and power level when door is opened. To change this option follow the step below.

- With door open press and hold the 100% pad  for 5 seconds until beep is heard. Close the door this changes timer setting to pause current cook time and power level when door is opened.

Timer pausing current cook time and power level can be set at any time to reset to zero and 100% power level when door is opened. To change this option follow the step below.

- With door open press and hold the 20% pad  for 5 seconds until beep is heard. Close the door this changes timer setting to reset timer to zero and power level to 100% when door is opened.

The switching operation of this microwave oven can cause voltage fluctuations on the supply line. The operation of this oven under unfavorable voltage supply conditions can have adverse effects. This device is intended for the connection to a power supply system with a maximum permissible system impedance Z_{max} of **0.2 Ohms** at the interface point of the user's supply. The user has to ensure that this device is connected only to a power supply system which fulfills the requirement above. If necessary, the user can ask the public power supply company for the system impedance at the interface point.

Quick Start Reference Guide (Electronic Control)

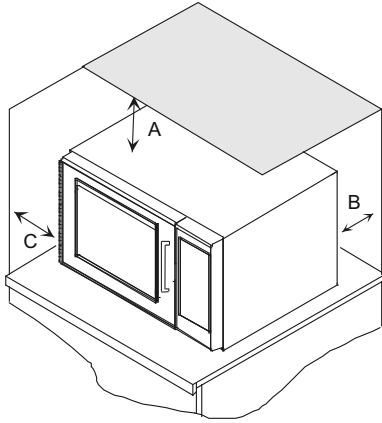

Oven Wall Clearances

A—For North American (UL/CSA) models, allow at least 2" (5.1 cm) of clearance around top of oven. For International (50 Hz) models, allow at least 12" (30 cm) of clearance around top of oven. Proper air flow around oven cools electrical components. With restricted air flow, oven may not operate properly and life of electrical parts is reduced.

B—Allow at least 2" (5.1 cm) between air discharge on back of oven and back wall.

C—Allow at least 2" (5.1 cm) of clearance around sides of oven.

So...how do I use it? (Electronic Control)

Manual Operation

To cook food using a specific entered time and power level:

1. Open oven door and place food in oven. Close door.
2. Press TIME ENTRY pad and enter cooking time.
3. Press a power level pad to change power level if desired (some models).
 - **COOK LEVEL** displays with the power setting.
4. If stage cooking is desired, press TIME ENTRY pad and repeat steps 2 through 4.
5. Press START pad.
6. At end of cooking cycle oven beeps and shuts off.

Programming Items

1. Open oven door.
2. Press and hold pad 1 for approximately 5 seconds.
3. Press pad to be reprogrammed.
4. Enter cooking time by using the number pads.
5. Press a power level pad to change power level if desired.
6. If stage cooking is desired, press TIME ENTRY pad.
 - Display briefly shows the stage number.
 - Display changes to cook time and power level for the next stage.
7. Enter cook time and power level as in steps 4 and 5 (some models).
 - To enter another cooking stage for that pad, press TIME ENTRY pad again.
 - Up to four different stages can be programmed (some models).
8. Press START pad to set new programming changes to the pad.

NOTE: To discard changes, press STOP/RESET pad or close oven door.

X2 Pad

1. Open oven door and place food in oven. Close door.
2. Press X2 pad.
3. Press desired preprogrammed pad or pad sequence.
4. Oven begins cooking. Displayed cooking time is the total of original cooking time and added X2 time.

6

Preprogrammed Pads

To cook food using preprogrammed cooking sequences:

1. Open oven door and place food in oven. Close door.
2. Press desired pad.
3. Oven begins to cook.
4. At end of cooking cycle oven beeps and shuts off.

X2

X2 Programming

To change the cooking factor:

1. Open oven door.
2. Press and hold pad 1 for approximately 5 seconds.
3. Press pad to be reprogrammed.
4. Press the X2 pad.
5. Press a numbered pad to change the cooking factor.
 - Cooking factor can be set from 10% to 100%.
 - Default is 80%.
 - Pad 5 would change the cooking factor to 50%.
6. Press START pad to save changes.

Quick Start Reference Guide (Electronic Control)

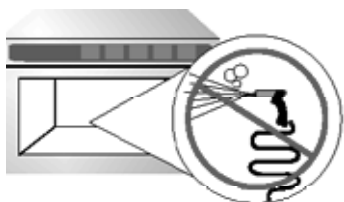

DO NOT power spray

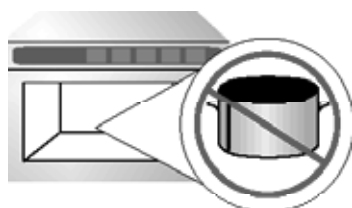



No metal pans



Can I change an option?

Options such as single or double pad programming, beep volume, and maximum cooking time can be changed to suit individual preferences.

To change options:

1. Open oven door.
 - If door is closed or STOP/RESET  pad is pressed before programming is complete, changes are discarded and microwave exits programming mode.
2. Press and hold pad 2 for approximately 5 seconds.
 - This begins options mode.
 - Microwave will beep and OP: displays.
3. Press number pad that controls option to be changed.
 - See table below for options.
 - Current option will display.
4. Press number pad again to change the option.
 - Each time pad is pressed, option will change.
 - Match code displayed with code for desired option.
5. Press START  pad to save changes.
 - To change additional options, repeat steps 3 and 4.
 - Changes appear after door is closed or STOP/RESET  pad is pressed.

Numbered Pads	Display	Options (Factory Settings in Bold)
1 End of Cycle Beep	OP:10 OP:11 OP:12	3 second beep. Continuous beep until door is opened. 5 beep bursts until door is opened.
2 Key Beep Volume	OP:20 OP:21 OP:22 OP:23	Eliminates beep. Sets volume to low. Sets volume to medium. Sets volume to high.
3 Key Beep	OP:30 OP:31	Prevents beep when pad is pressed. Allows beep when pad is pressed.
4 Active Display	OP:40 OP:41 OP:42 OP:43	15 seconds after oven door is opened, keyboard disabled. 30 seconds after oven door is opened, keyboard disabled. 1 minute after oven door is opened, keyboard disabled. 2 minutes after oven door is opened, keyboard disabled.
5 On-the Fly Cooking	OP:50 OP:51	Prevents different pre-programmed pads to be activated during cooking. Allows different pre-programmed pads to be activated during cooking.
6 Reset to Ready Mode	OP:60 OP:61	Opening oven door does not reset oven back to ready mode. Opening oven door resets oven back to ready mode.
7 (some models) Maximum Heating Time	OP:70 OP:71	Allows 60 minutes of heating time (some models). Allows 10 minutes of heating time.
8 Manual Operation	OP:80 OP:81	Allows use of preprogrammed pads only. Allows use of manual time entry and preprogrammed pads.
9 (some models) Double Digit Operation	OP:90 OP:91	Allows 10 (0-9) preprogrammed pads. Allows 100 (00-99) preprogrammed pads.
0 Clean Filter Message	OP:00 OP:01 OP:02 OP:03	Do not display message. Display message for 24 hours every 7 days. Display message for 24 hours every 30 days. Display message for 24 hours every 90 days.

Components Location (Oven Cavity)

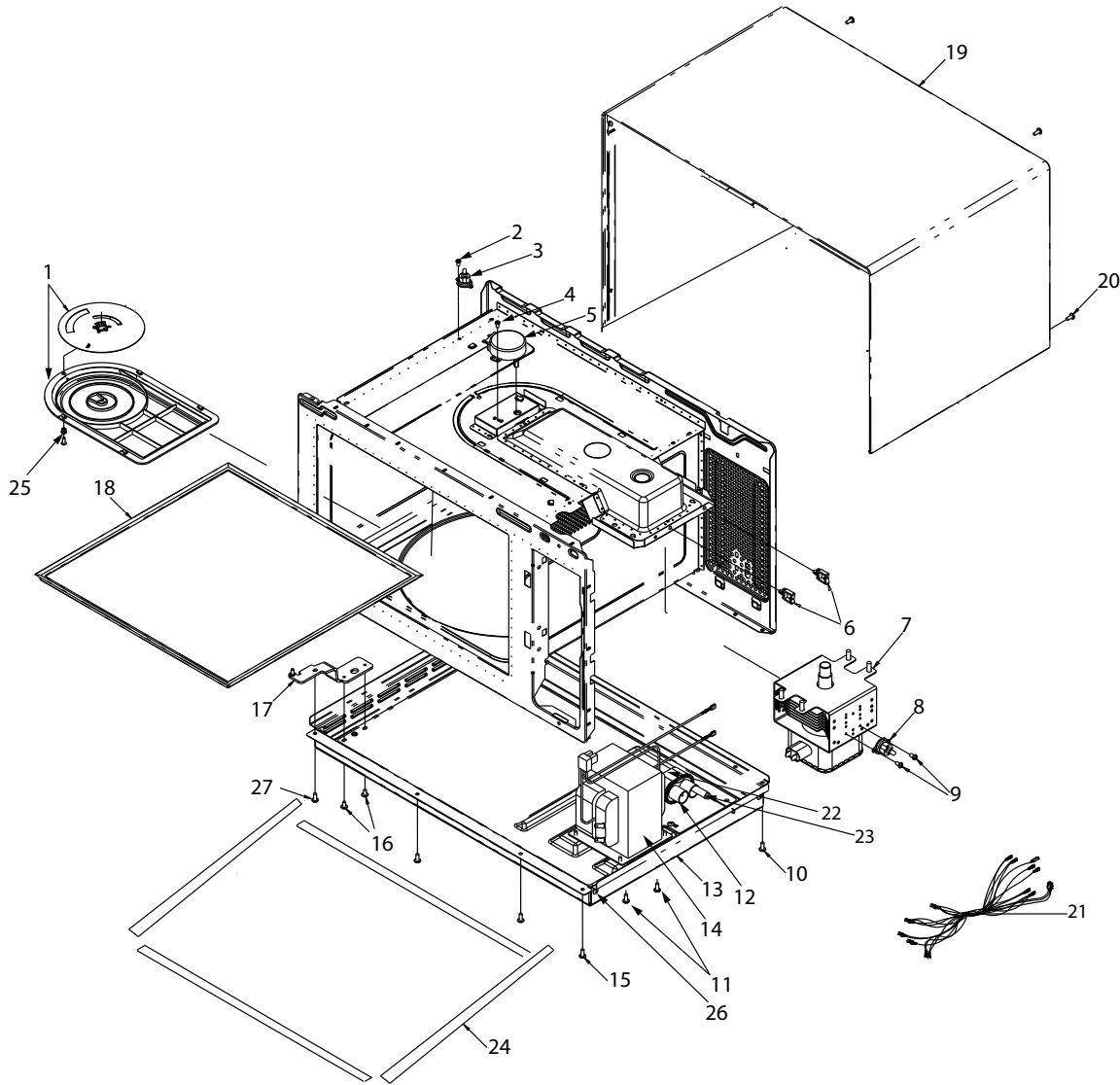

Reference	Part Number	Description	Quantity
1	12002625	KIT, COVER / STIRRER BLADE/ RIVETS	1
2	54127062	SCREW	1
3	54127037	THERMAL CUTOUT, CAVITY	1
4	54127062	SCREW	1
5	56002013	MOTOR, ANTENNA	1
6	B5667304	CLIP -WIRE	2
7	14114048	MAGNETRON	1
8	54127038	THERMAL CUTOUT, MAG	1
9	54116025	SCREW	2
10	54127064	SCREW	1
11	54127061	SCREW	4
12	54127015	CAPACITOR- 1.05	1
13	54127001	BASEPAN ASSY	1
14	54127011	TRANSFORMER HV	1
15	54127064	SCREW	3
16	54127061	SCREW	2
17	54127029	HINGE, LOWER	1
18	54127019	TRAY, CERAMIC	1
19	54127045	WRAPPER	1
20	54127064	SCREW	4
21	54127042	HARNES, MAIN	1
22	53001724	BRACKET, CAPACITOR	1
23	20036801	DIODE	1
24	R0000413	BASEPAN GASKET	1
25	54116064	RIVET ASSY	1
26	54116021	SCREW	4
27	54127066	SCREW	1

Components Location (Blower / Interlock)

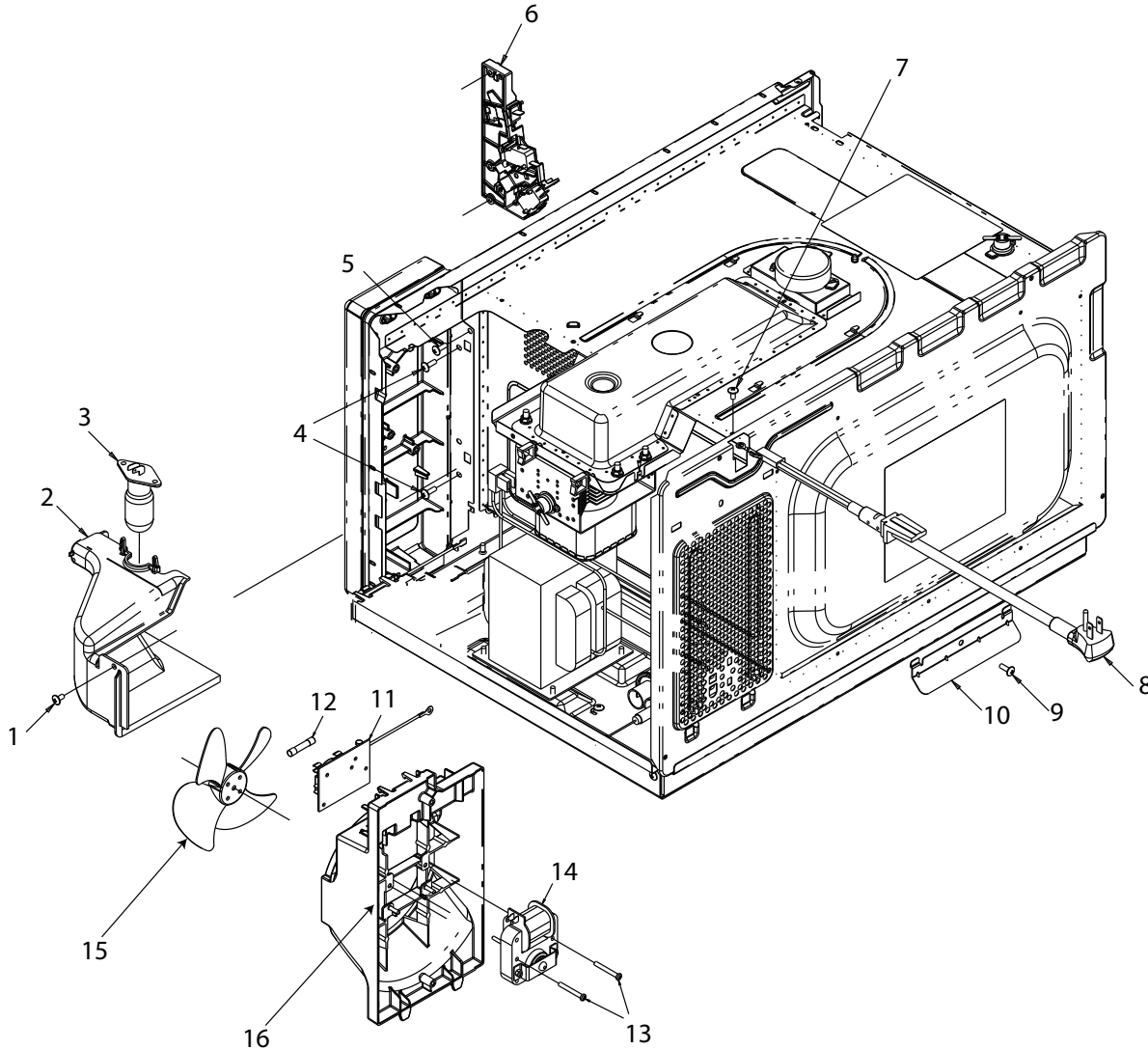

Reference	Part Number	Description	Quantity
1	54116017	SCREW	1
2	54127039	DUCT, MAG	1
3	54127049	LAMP / SOCKET ASSY	1
4	54116017	SCREW	2
5	54116017	SCREW	1
6	54127009	INTERLOCK SWITCH ASSY	1
7	54116017	SCREW	1
8	54127048	POWER CORD	1
9	54116017	SCREW	1
10	54127040	BRKT, INLET AIR	1
11	54127036	FUSE BLOCK / FILTER ASSY	1
12	20034003	FUSE	1
13	54127065	SCREW	2
14	54127056	MOTOR, BLOWER & BLADE	1
15	56112070	BLADE, FAN	1
16	54127059	BRKT, BLOWER	1

Components Location (Dial Control)

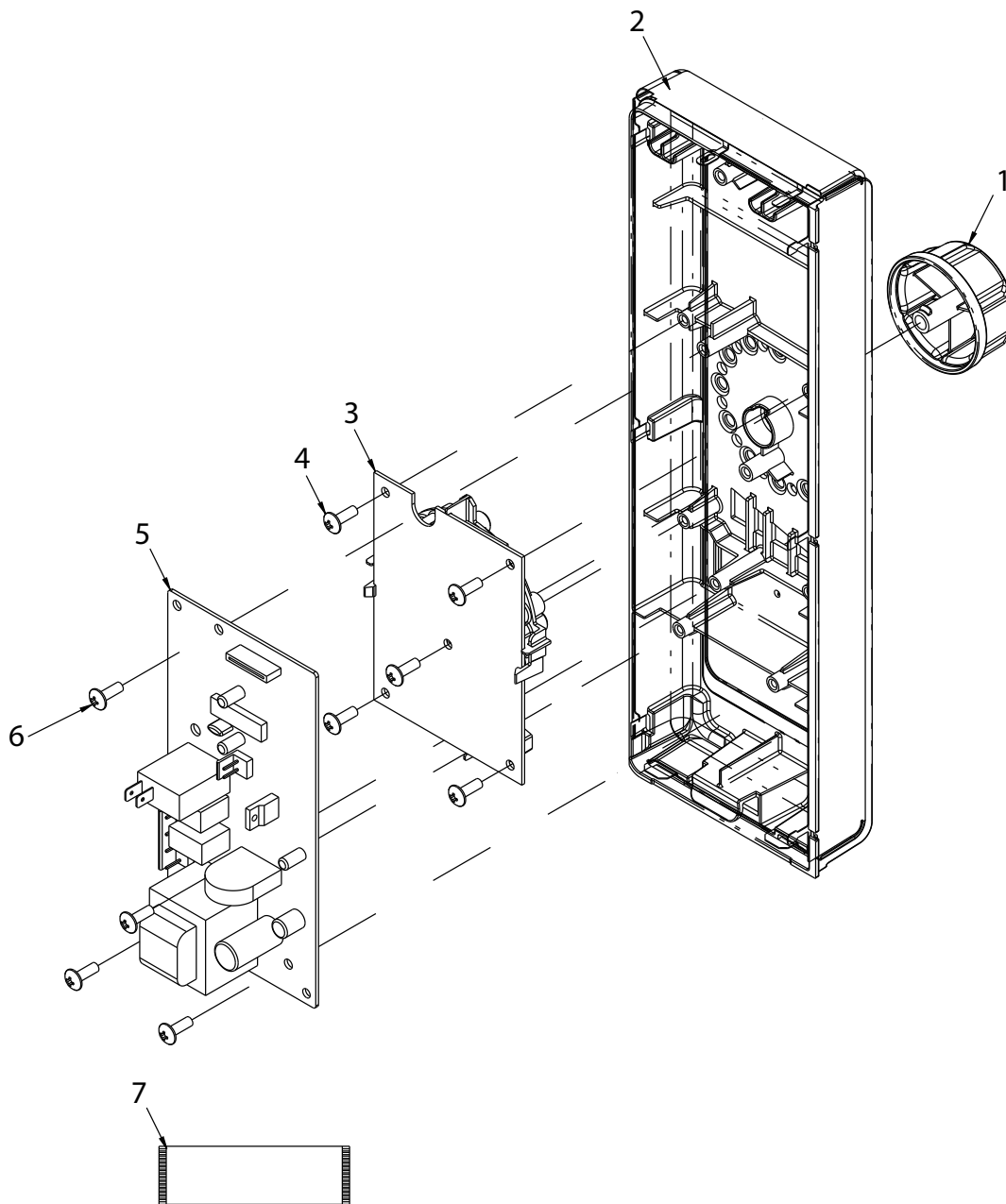

Reference	Part Number	Description	Quantity
1	54127053	KNOB	1
2	54127002	ESC / TOUCH PANEL ASSY (RCS10DSE)	1
2	54127004	ESC / TOUCH PANEL ASSY (MCS10DSE)	1
3	54127031	BOARD, LED (RCS10DSE)	1
3	54127054	BOARD, LED (MCS10DSE)	1
4	54127067	SCREW	5
5	54127030	BOARD, HV / LV	1
6	54127067	SCREW	4
7	54127032	HARNESS, PCB	1

Components Location (Electronic Control)

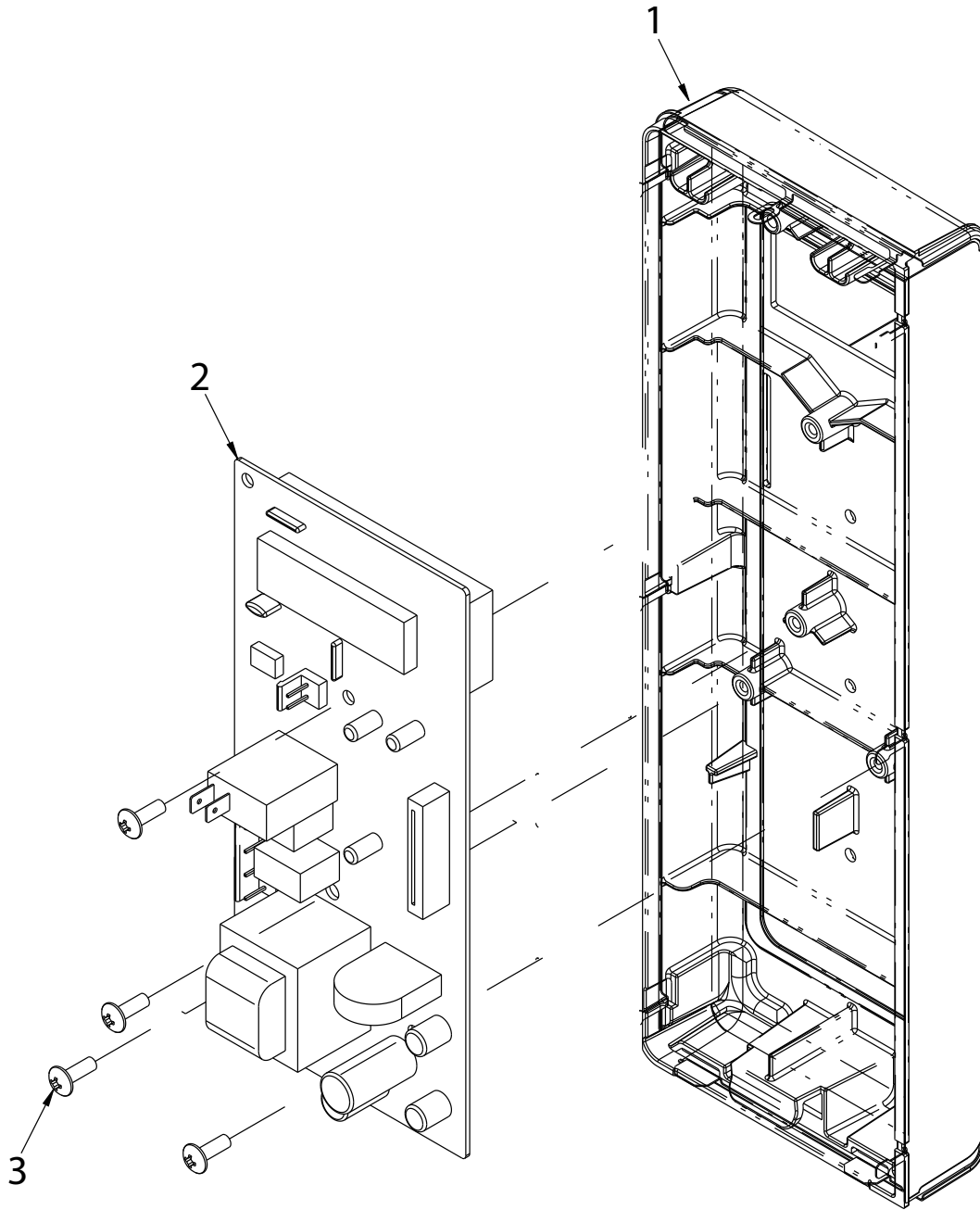

Reference	Part Number	Description	Quantity
1	54127003	ESC / TOUCH PANEL ASSY (RCS10TS)	1
1	54127005	ESC / TOUCH PANEL ASSY (MCS10TS)	1
2	54127033	BOARD, HV / LV	1
3	54127067	SCREW	4

Components Location (Door)

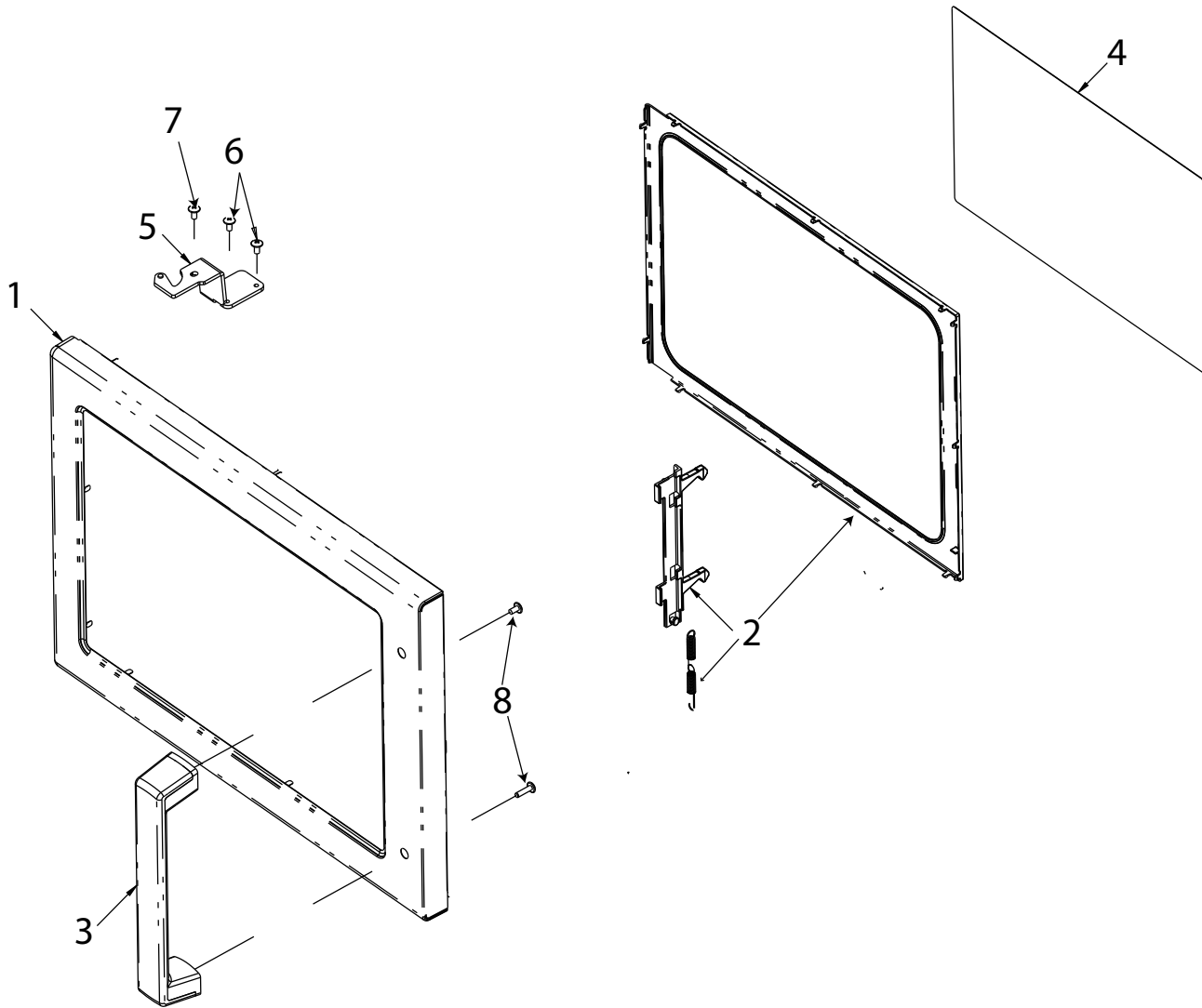

Reference	Part Number	Description	Quantity
1	54127021	DOOR ASSY (RCS10*)	1
1	54127023	DOOR ASSY (MCS10*)	1
2	14124068	KIT, SPRING/LATCH/CHOKE COVER	1
3	14124069	KIT, DOOR HANDLE	1
4	54127027	WINDOW, INNER	1
5	54127028	HINGE, UPPER	1
6	54127061	SCREW	2
7	54127064	SCREW	1
8	54127063	SCREW	2

Performance Testing Procedures



WARNING

To avoid risk of electrical shock, personal injury or death, disconnect power to oven and discharge capacitor before servicing, unless testing requires it.

All Amana and Menumaster microwave oven power outputs are rated using the IEC705 standards. Using the IEC705 test method requires precision measurements and equipment that is not practical to be performed in the field. Using the test shown below will indicate if the oven performance is satisfactory.

Test equipment required:

- 1000 ml test container and thermometer.
- Digital watch / watch with a second hand for use on ovens with electromechanical timers.

Important Notes:

- Low line voltage will cause low temperature rise / power output.
- Ovens must be on a dedicated circuit, properly grounded, and polarized. Other equipment on the same circuit may cause a low temperature rise / power output.
- This test and results are not a true IEC705 test procedures and are only intended to provide servicers with an easy means of determining if the microwave oven cooking output is correct.

Procedure

1. Fill the test container to the 1000 ml line with cool tap water.

NOTE: Water temperature should be approximately 60°F / 16°C

2. Using the thermometer, stir water for five to ten seconds; measure, and record the temperature (T1).
3. Place test container of water in the center of oven cavity and close door.
4. Heat the water for a 33-second full power cycle.

NOTE: Use a digital watch or a watch with a second hand for ovens with electromechanical timers.

5. At end of the cycle, remove test container. Using the thermometer, stir water for five to ten seconds and record temperature (T2).
6. Subtract the starting water temperature (T1), from the ending water temperature (T2) to obtain the temperature rise (ΔT).
7. If the temperature rise (ΔT) meets or exceeds the minimum, the test is complete. If the temperature rise (ΔT) fails to meet the minimum temperature rise, test the line voltage to verify it is correct. Then repeat steps 1 - 6 making sure to change the water. If the temperature rise (ΔT) fails to meet the minimum temperature rise again the oven will require service.

Minimum Temperature Rise at Thirty -Three (33) Seconds Run Time

ΔT (°F)	Cooking Power Output	ΔT (°F)	Cooking Power Output	ΔT (°C)	Cooking Power Output	ΔT (°C)	Cooking Power Output
10	1000	20	2000	5	1000	11	2000
11	1100	21	2100	5.5	1100	11.5	2100
12	1200	22	2200	6.5	1200	12	2200
14	1400	24	2400	7.5	1400	13	2400
17	1700	25	2500	9.5	1700	13.5	2500
18	1800	27	2700	10	1800	15	2700
19	1900	30	3000	10.5	1900	16.5	3000

Component Testing Procedures



WARNING

To avoid risk of electrical shock, personal injury or death; disconnect power to oven and discharge capacitor before servicing, unless testing requires power.

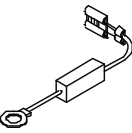
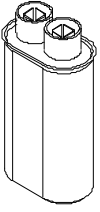
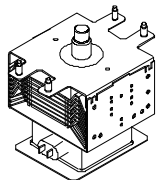
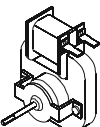
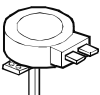
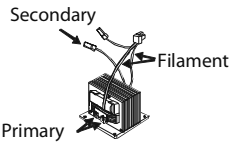
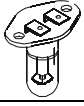
Illustration	Component	Testing	Results
	Thermal cutout	Disconnect all wires from TCO. Measure resistance across terminals. Cavity TCO Magnetron TCO	Opens at 212°F (100°C) Closed at 140°F (60°C) and Opens at 320°F (160°C)
	Diode	Discharge Capacitor Remove diode lead from capacitor and connect ohmmeter. Reverse leads for second test.	Infinite resistance should be measured in one direction and 50K Ω or more in the opposite direction. NOTE: Ohmmeter must contain a battery of 6 volts minimum.
	Capacitor	Discharge Capacitor Remove wires from capacitor terminals and connect ohmmeter, set on highest resistance scale to terminals. Also check between each terminal and capacitor case.	Between Terminals: Meter should momentarily deflect towards zero then return to over 5 M Ω. If no deflection occurs, or if continuous deflection occurs, replace capacitor. Terminal to Case: Infinite resistance
	Magnetron	Discharge Capacitor Remove wires from magnetron and connect ohmmeter to terminals. Also check between each terminal and ground.	Between Terminals: Less than 1 Ω Each terminal to ground measures Infinite resistance. Note: This test is not conclusive. If oven does not heat and all other components test good replace the magnetron and retest.
	Blower motor	Remove all wires from motor. Measure resistance across coil.....	Approximately 44 Ω
	Stirrer motor	Remove all wires from motor. Measure resistance across terminals.....	Approximately 3.8K Ω
	Transformer	Discharge Capacitor Remove all wires from terminals. Measure resistance from: Primary..... Filament..... Secondary to Ground screw on transformer stack.....	Less than <1 Ω Less than <1 Ω Approximately 75 Ω
	Lamp and receptacle	Test continuity of receptacle terminals.	Indicates continuity with bulb installed.
	Wire Harness	Test continuity of wires	Indicates continuity

Component Testing Procedures



WARNING

To avoid risk of electrical shock, personal injury or death; disconnect power to oven and discharge capacitor before servicing, unless testing requires power.

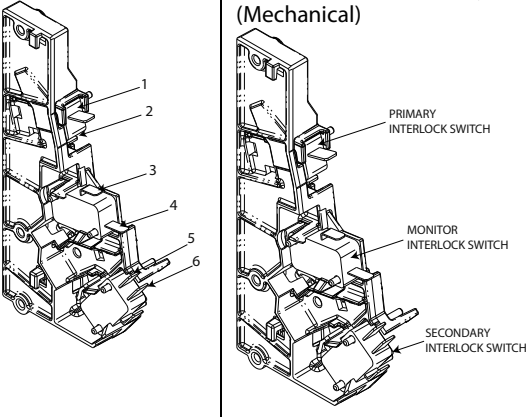
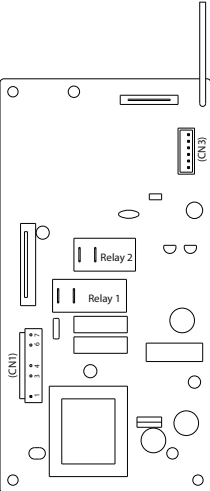
Illustration	Component	Testing	Results
	Fuse block / Filter assembly	Power In terminals..... Power Out terminals	120 VAC 120 VAC If no power in, check power outlet If no power out, check fuses
	Interlock switch assembly (Mechanical)	Disconnect wires to switch. With door open measure resistance from: Monitor – Terminals 3 - 4..... Primary – Terminals 1 - 2..... Secondary – Terminals 5 - 6..... With door closed measure resistance from: Monitor – Terminals 3 - 4..... Primary – Terminals 1 - 2..... Secondary – Terminals 5 - 6..... After verifying or replacing the module, re-connect wires to switch and check operation of monitor circuit before operating the oven.	Indicates continuity Infinite Ω Infinite Ω Infinite Ω Indicates continuity Indicates continuity
	Dial Electronic control	<ol style="list-style-type: none"> (CN1 connector) Measure voltage at BN (1) and BL (3) terminal leads (Relay 1) Measure voltage across BL and WH terminal leads..... (Relay 2) Measure voltage across BL and WH terminal leads..... 	Approximately 120 VAC 120 VAC OFF position (Door Closed) 0 volts Cook mode (Door Closed) 120 VAC OFF position (Fan/Light Off) 0 volts (Fan/Light ON)

Troubleshooting

Service Diagnostics

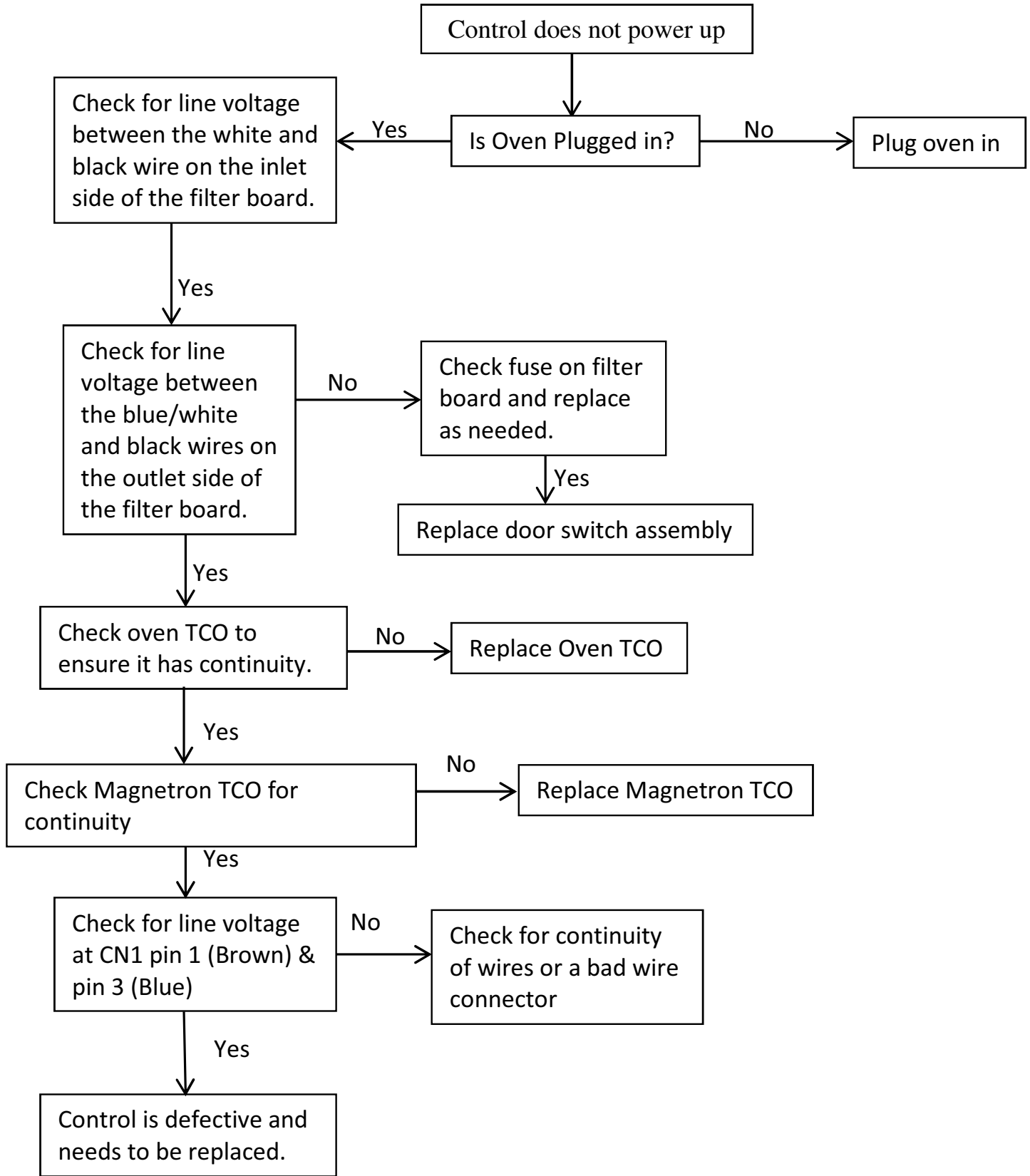

Troubleshooting

Service Diagnostics

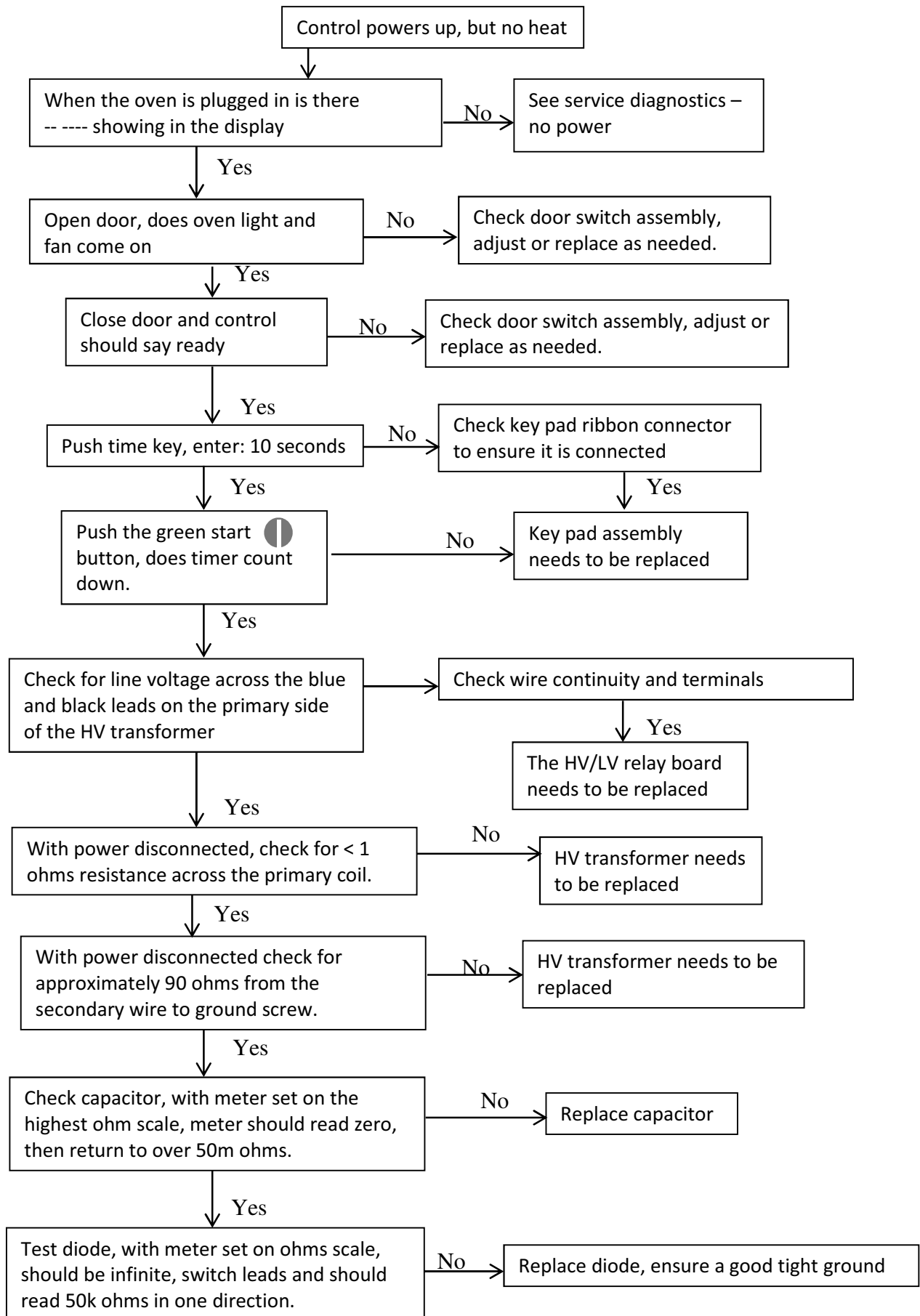

Schematic / Wiring Diagram RCS10* / MCS10*

SCHEMATIC DIAGRAM

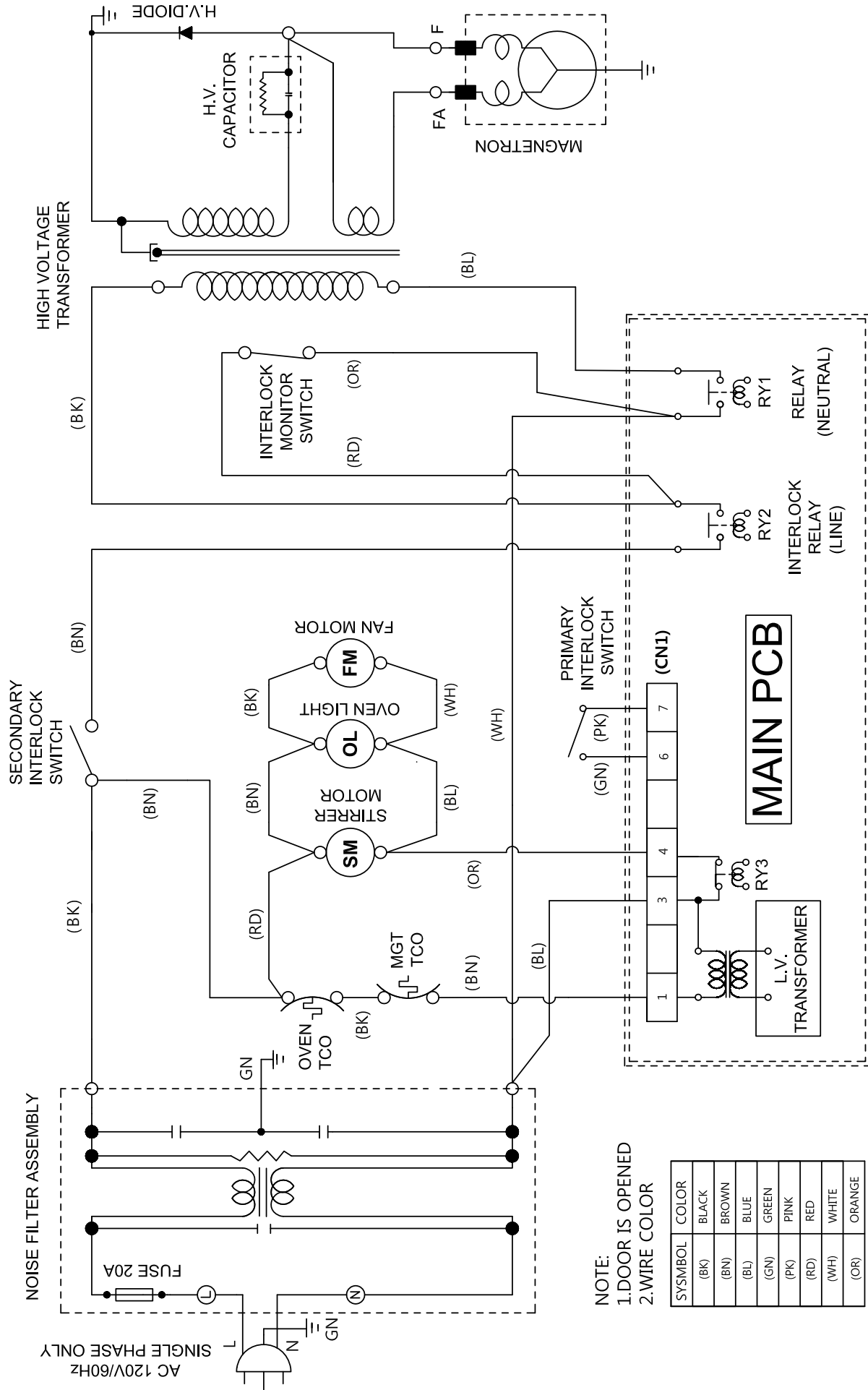

NOTE:
 1. DOOR IS OPENED
 2. WIRE COLOR

SYMBOL	COLOR
(BK)	BLACK
(BN)	BROWN
(BL)	BLUE
(GN)	GREEN
(PK)	PINK
(RD)	RED
(WH)	WHITE
(OR)	ORANGE

BEFORE SERVICING Discharge the high voltage capacitor by shorting the negative high voltage terminal of it to chassis ground

Notes:

