

Repair Parts List

MODEL NUMBER

RFS12SW2A

MANUFACTURING
NUMBER

P1330208M

COMMERCIAL MICROWAVE

When requesting service or ordering parts, always provide the following information:

- Product Type
- Part Number
- Model Number
- Part Description

Amana[®]
HIGH PERFORMANCE HAS A NAME™

PART OF  FOODSERVICE GROUP

December 15 2006

Section: DOOR

Model: RFS12SW2A_P1330208M

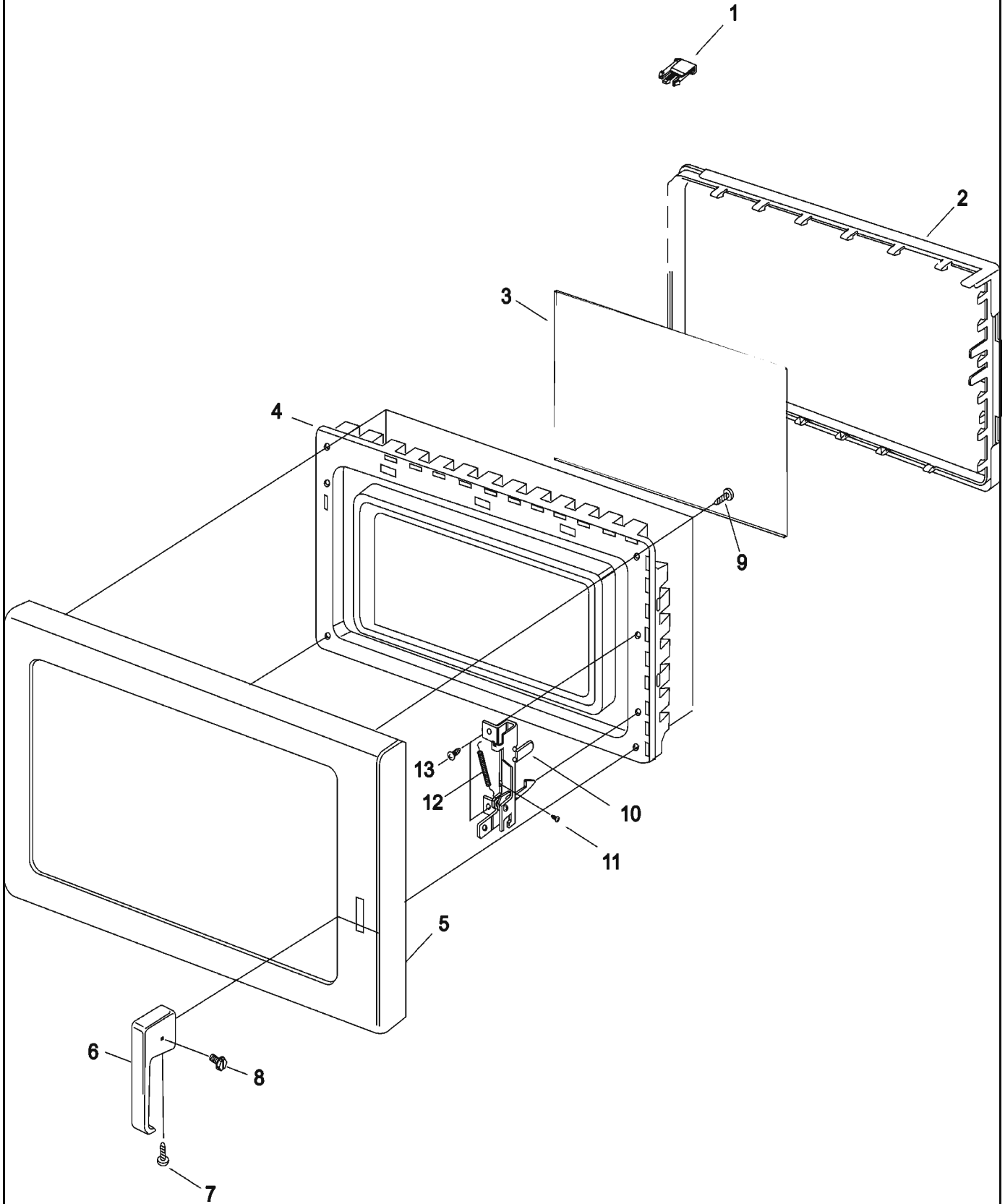

Section: DOOR

No.	Part No.	Description	Series Qty
1	53001543	CAP, TOP HINGE	1
2	53001572	CHOKE COVER	1
3	13066801	WINDOW, INNER DOOR	1
4	53001778	INNER DOOR WELDMENT	1
5	53001573	ASSY, OUTER DOOR (SS)	1
6	12002453	HANDLE KIT- W/SCREWS & LOCTITE	1
7	53001546	SCREW- HANDLE BOTTOM	1
8	53001547	SCREW- HANDLE SIDE	1
9	R0654030	SCREW, PAN HD S/TAP	4
10	53001779	LATCH	1
11	R0654180	SCREW, PAN HD	1
12	53001780	SPRING	1
13	R0131246	SCREW, TAPPING TRUSS HEAD	2

Section: TIMER AND ESCUTCHEON

Model: RFS12SW2A_P1330208M

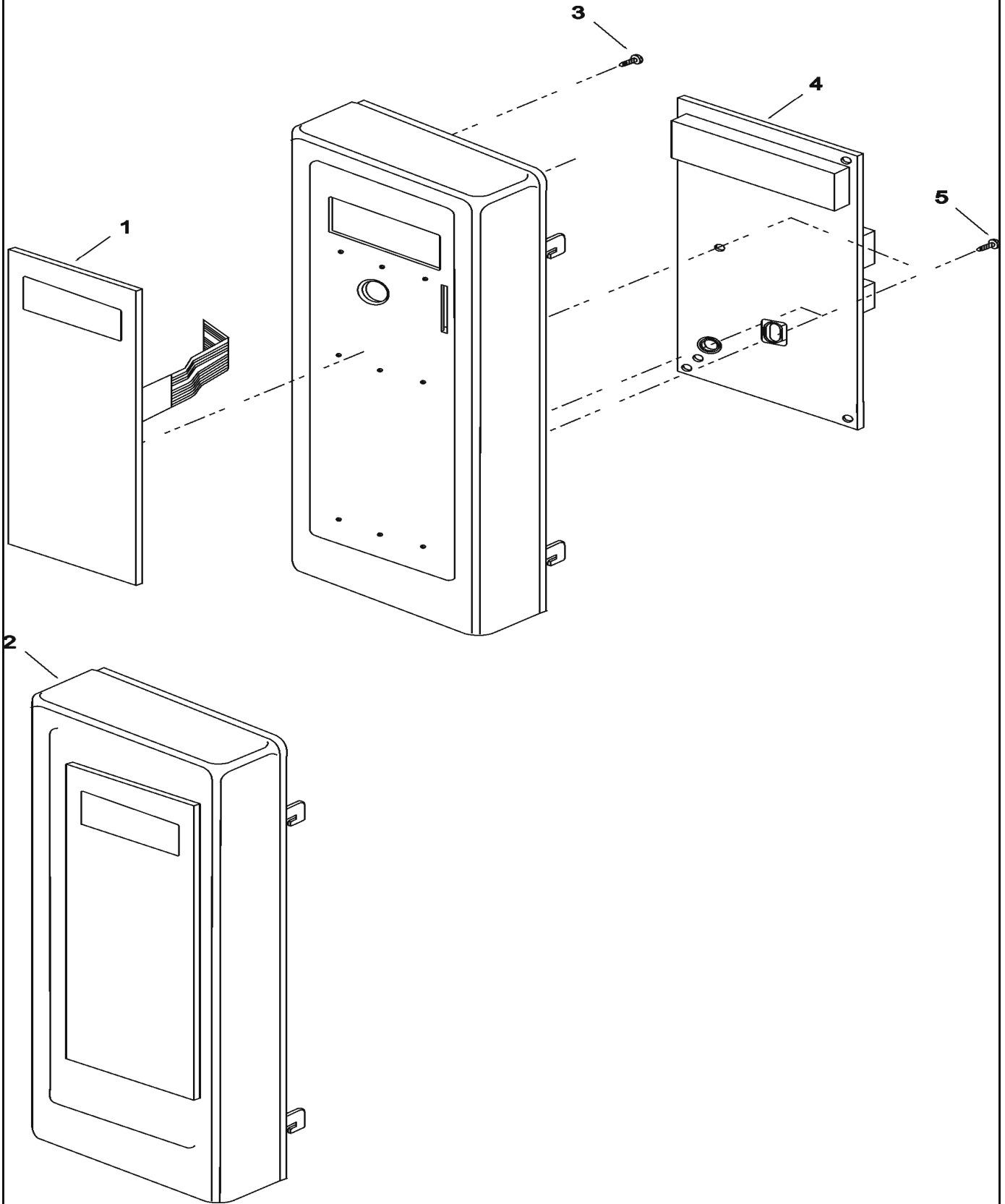

Section: TIMER AND ESCUTCHEON

No.	Part No.	Description	Series Qty
1	53001874	TOUCH PANEL	1
2	53001808	ESCUTCHEON/ TOUCH PANEL ASSY	1
3	R0654178	SCREW, SPECIAL D	1
4	53001806	HV/ LV BOARD	1
5	53001462	SCREW, PAN HEAD	3

Section: ANTENNA, TRAY, OUTER CASE,

Model: RFS12SW2A_P1330208M

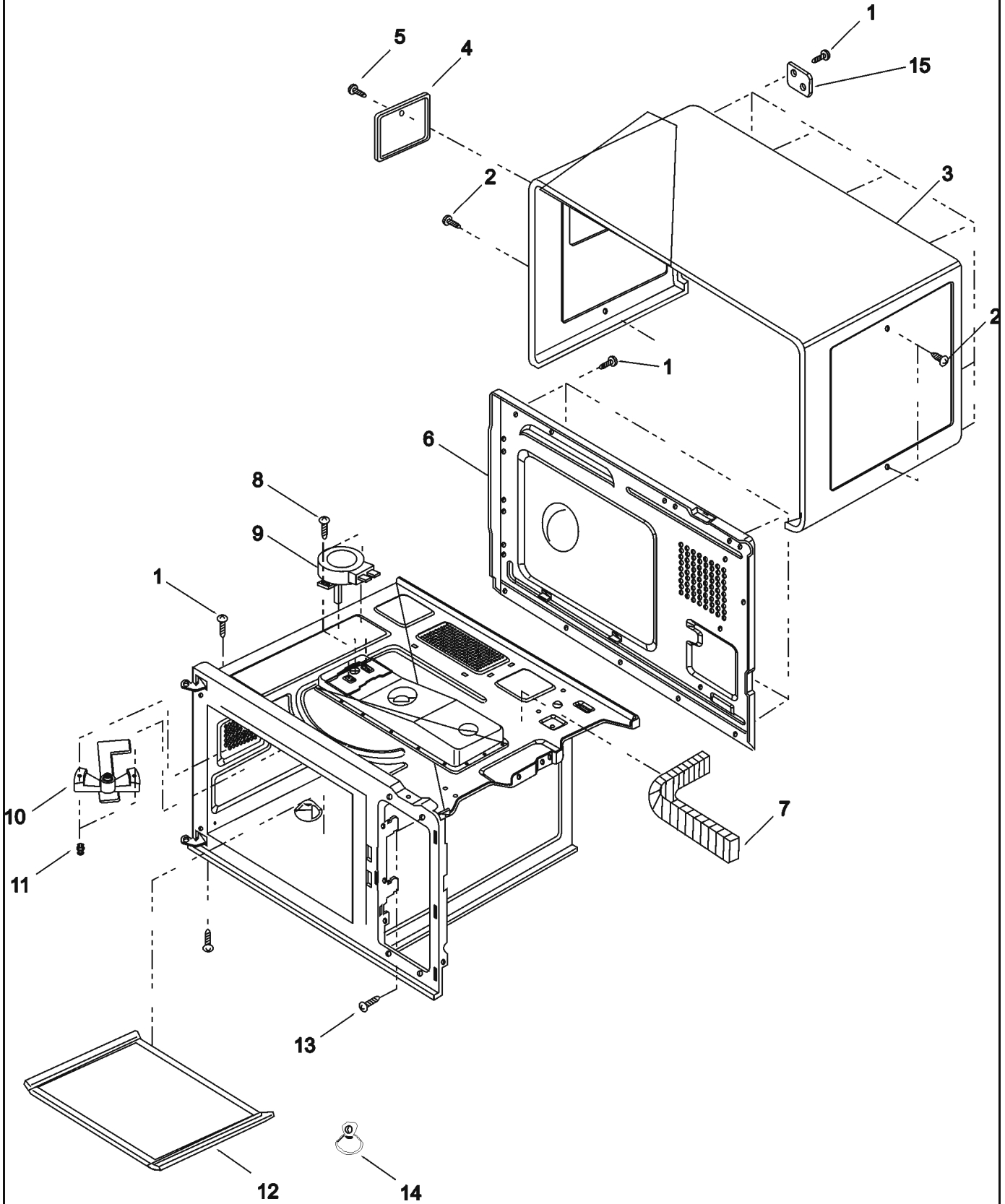

Section: ANTENNA, TRAY, OUTER CASE,

No.	Part No.	Description	Series Qty
1	R0654183	SCREW, TRUSS HD	14
2	R0654036	SCREW, TRUSS HD S/TAP	4
3	53001577	OUTER CASE- STAINLESS	1
4	53001579	COVER, LAMP- STAINLESS	1
5	53001609	SCREW TAPPING, COUNTER SUNK HD	1
6	53001551	BACK PANEL	1
7	53001610	GASKET	1
8	R0654180	SCREW, PAN HD	2
9	59001186	MOTOR, ANTENNA 120V 60HZ	1
10	12002451	ANTENNA KIT- W/RIVETS	1
11	53001554	RIVET ASSEMBLY	1
12	53001555	TRAY, CERAMIC	1
13	R0131246	SCREW, TAPPING TRUSS HEAD	1
14	59001235	SUCTION CUP- FOR TRAY REMOVAL	1
15	53001619	BRACKET, STACKING	1

12/06

*Color Code (-)=Not Shown #=Series, Serial Prefix or Run No., N=Not Available

Section: ELECTRICAL, GREASE SHIELD, DUCTS,

Model: RFS12SW2A_P1330208M

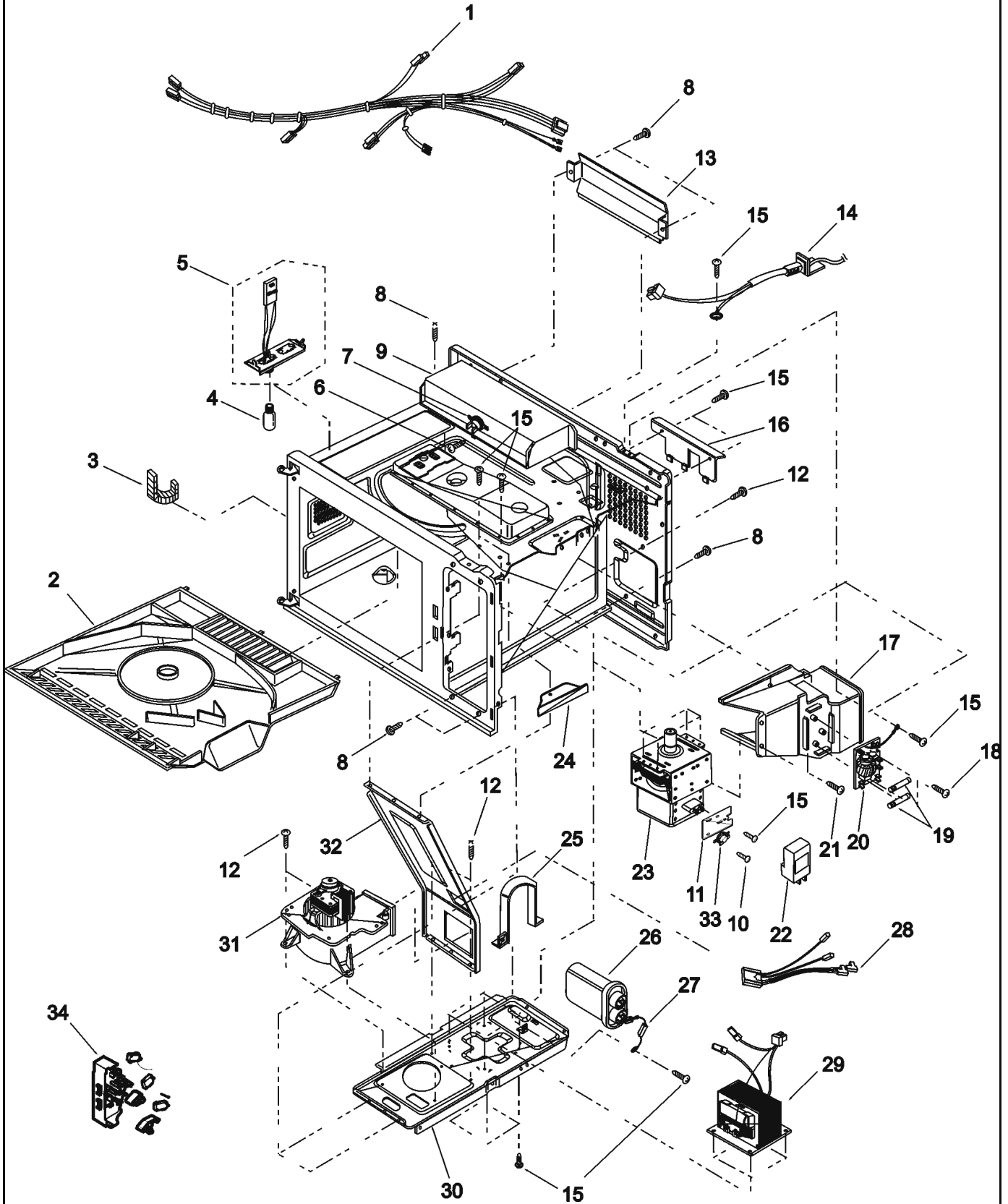

Section: ELECTRICAL, GREASE SHIELD, DUCTS,

No.	Part No.	Description	Series Qty
1	53001646	HARNES, MAIN	1
2	53001556	GREASE SHIELD	1
3	53001610	GASKET	1
4	53001557	LAMP	1
5	53001558	LAMP SOCKET / BRACKET ASSY	1
6	R0654030	SCREW, PAN HD S/TAP	1
7	53001561	THERMAL CUT OUT- CAVITY	1
8	R0131246	SCREW, TAPPING TRUSS HEAD	5
9	53001559	DUCT, OUTLET-TOP	1
10	R0131307	SCREW TAPPING,PAN HEAD	1
11	53001643	BRACKET- THERMOSTAT	1
12	R0654183	SCREW, TRUSS HD	5
13	53001620	AIR DEFLECTOR	1
14	53001580	POWER CORD	1
15	R0654028	SCREW, BINING HD S/TAP	11
16	53001621	COVER, POWER CORD	1
17	53001563	DUCT, MAIN	1
18	53001462	SCREW, PAN HEAD	2
19	M0805106	FUSE, 10 AMP	2
20	53001564	FUSE BLOCK / FILTER ASSY	1
21	R0654180	SCREW, PAN HD	1
22	53001565	FILTER ASSEMBLY	1
23	53001581	MAGNETRON	1
24	53001622	BRACKET	1
25	53001623	BRACKET, CAPACITOR	1
26	53001582	CAPACITOR- 1.05 MF	1
27	53001583	DIODE- RED SLEEVE	1
28	53001624	HARNES- TRANSFORMER PRIMARY	1
29	53001584	TRANSFORMER HV	1
30	53001568	BASE- TRANSFORMER	1
31	53001569	BLOWER MOTOR ASSY	1
32	53001570	GUIDE, AIR	1
33	53001560	THERMAL CUT OUT- MAGNETRON	1
34	53001601	SWITCH ASSY, INTERLOCK	1

Section: BASE AND FILTER

Model: RFS12SW2A_P1330208M

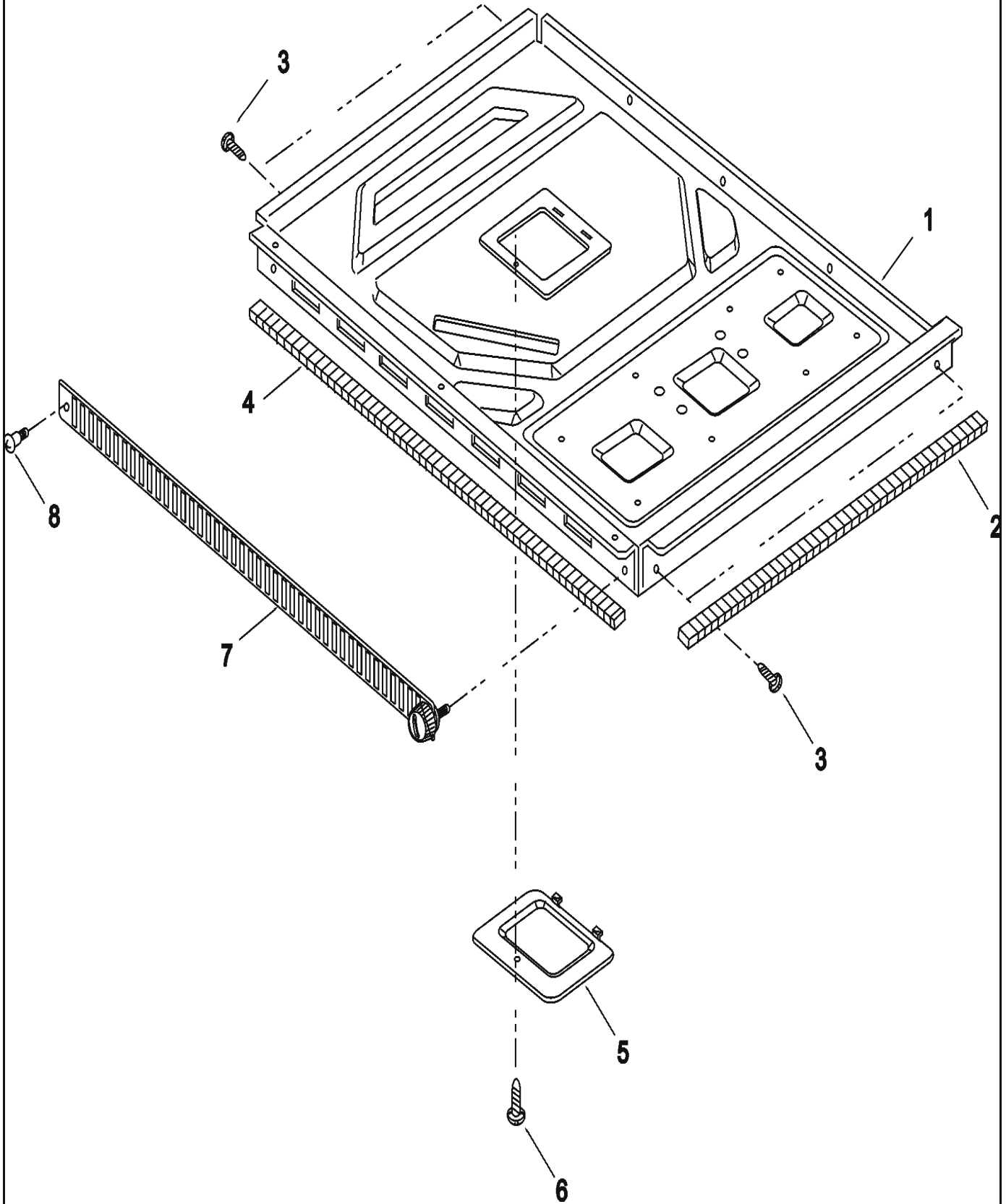

Section: BASE AND FILTER

No.	Part No.	Description	Series Qty
1	53001625	BASE PLATE- W/COVER & GASKETS	1
2	53001626	GASKET, BASE- SIDE	2
3	R0654036	SCREW, TRUSS HD S/TAP	2
4	53001627	GASKET, BASE- FRONT	2
5	53001628	COVER, BASE	1
6	R0131246	SCREW, TAPPING TRUSS HEAD	1
7	53001571	FILTER, AIR- W/THUMB SCREW	1
8	53001629	SCREW, DRAWING	2

Section: SUPPLEMENTAL INFORMATION

No.	Part No.	Description	Series Qty
1	16023293	SRV MAN, 2004 RCS COMM MICROWA	1
2	N 53001634	USE & CARE	1
3	16023295	TECH SHT, 2004 RCS/RFS COMM MW	1

Section: WIRING INFORMATION

Model: RFS12SW2A_P1330208M

NOTE:

1. DOOR IS OPENED.
2. WIRE COLOR.

SYMBOL	COLOR
BN	BROWN
WH	WHITE
BK	BLACK
BL	BLUE
YL	YELLOW
PK	PINK
RD	RED
GN	GREEN

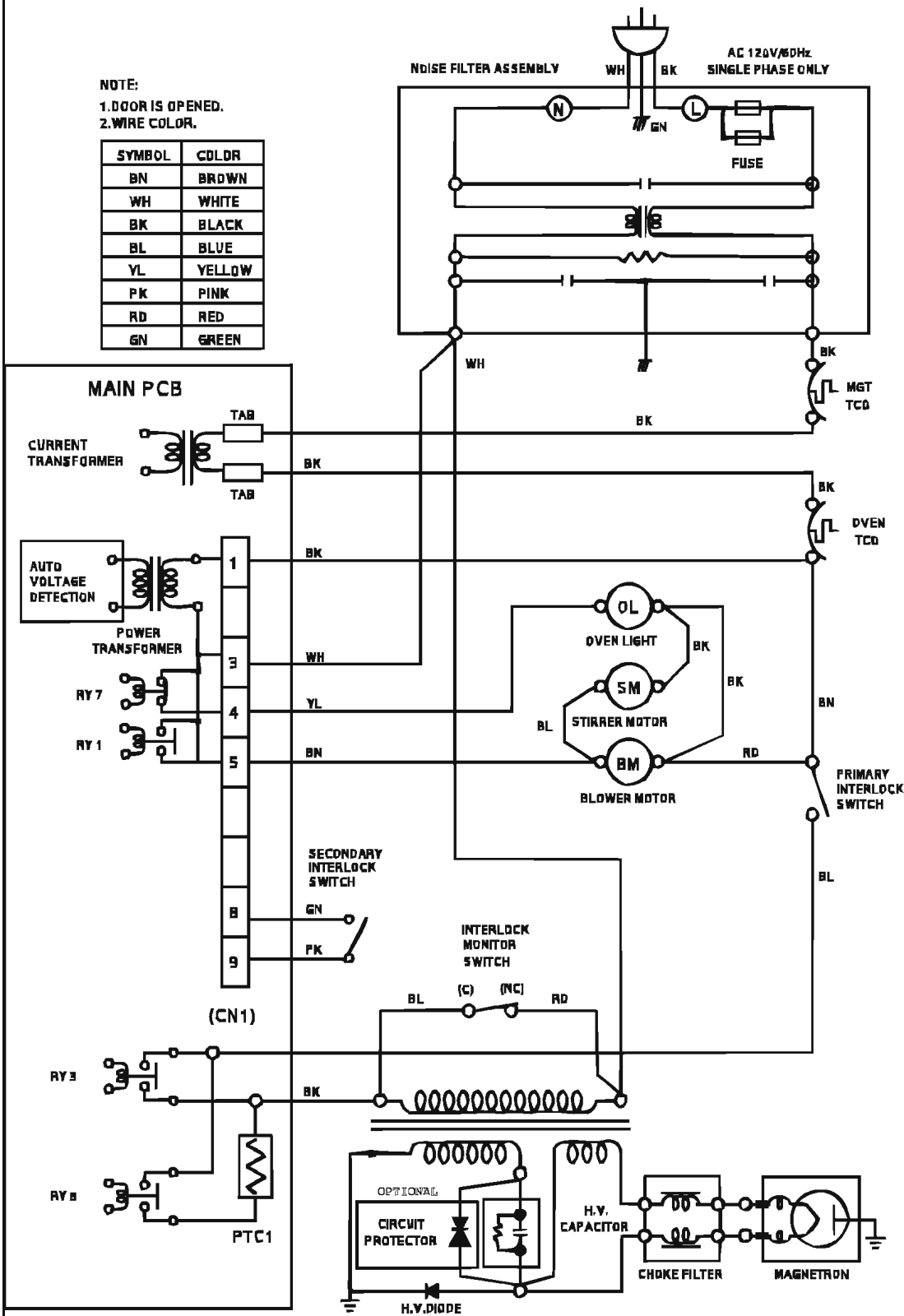

IMPORTANT SAFETY NOTE: THE SHADED AREAS ON THIS SCHEMATIC DIAGRAM INCORPORATE SPECIAL FEATURES IMPORTANT FOR PROTECTION FROM MICROWAVE RADIATION/ELECTRICAL SHOCK, AND HAZARDS. WHEN SERVICING IT IS ESSENTIAL THAT ONLY MANUFACTURER'S SPECIFIED PARTS BE USED FOR THE CRITICAL COMPONENTS IN THE SHADED AREAS OF THE SCHEMATIC DIAGRAM.

NOTICE: SINCE THIS IS BASIC SCHEMATIC DIAGRAM, THE VALUES OF COMPONENTS AND SOME PARTIAL CONNECTIONS ARE SUBJECT TO CHANGE FOR IMPROVEMENT.