

DFW-150/250

Deluxe Food Warmer

owner's manual

Manufacturing Number:

9100162, 9100165 &
9100169

Table of Contents

General	2
Warranty Information.....	2
Service/Technical Assistance.....	2
Important Safety Information.....	3
Warnings	3
Specifications	4
Shipping Weight.....	4
Capacities.....	4
Installation	5
Electrical.....	5
Plumbing	6
Operating Instructions.....	7
Programming	7
Recommended Settings.....	7
Hi-Limit Reset Button	8
Fault Codes	8
Diagnostic LEDs.....	8
Daily Maintenance	8
Monthly Maintenance	9
Troubleshooting.....	11
Replacement Parts.....	13
Wiring Diagram	17
Notes.....	19
Limited Warranty.....	20

⚠ IMPORTANT ⚠

A.J. Antunes & Co. reserves the right to change specifications and product design without notice. Such revisions do not entitle the buyer to corresponding changes, improvements, additions or replacements for previously purchased equipment.

⚠ IMPORTANT ⚠

Keep these instructions for future reference. If the unit changes ownership, be sure this manual accompanies the equipment.

GENERAL

The Deluxe Food Warmer (steamer) produces a steam using plain tap water for quick heating and reconstituting of food items. Simple push-button action delivers a shot of water that is immediately converted into steam. Because the amount of steam is consistent, it removes the guesswork and produces a uniform finish from one operator to the next.

This manual provides the safety, installation, and operating procedures for the Deluxe Food Warmer (steamer). We recommend that all information contained in this manual be read prior to installing and operating the unit.

Your Deluxe Food Warmer (steamer) is manufactured from the finest materials available and is assembled to Roundup's strict quality standards. This unit has been tested at the factory to ensure dependable trouble-free operation.

WARRANTY INFORMATION

Please read the full text of the Limited Warranty in this manual.

If the unit arrives damaged, contact the carrier immediately and file a damage claim with them. Save all packing materials when filing a claim. Freight damage claims are the responsibility of the purchaser and are not covered under warranty.

The warranty does not extend to:

- Damages caused in shipment or damage as result of improper use.
- Installation of electrical service.
- Normal maintenance as outlined in this manual.
- Malfunction resulting from improper maintenance.
- Damage caused by abuse or careless handling.
- Damage from moisture into electrical components.
- Damage from tampering with, removal of, or changing any preset control or safety device.

SERVICE/TECHNICAL ASSISTANCE

If you experience any problems with the installation or operation of your unit, contact your local Roundup Authorized Service Agency.

Fill in the information below and have it handy when calling your Authorized Service Agency for assistance. The serial number is on the specification plate located on the rear of the unit.

Purchased From

Date of Purchase

Model Number

Serial Number

Manufacturing Number

Use only genuine Roundup replacement parts in this unit. Use of replacement parts other than those supplied by the manufacturer will void the warranty. Your Authorized Service Agency has been factory trained and has a complete supply of parts for this unit.

Visit www.ajantunes.com or contact the factory at 1-630-784-1000 to locate your nearest Authorized Service Agency.

Refer to the service agency directory packaged with your manual and fill in the information below.

Authorized Service Agency

Name

Phone Number

Address

IMPORTANT SAFETY INFORMATION

Use the following guidelines for safe operation of the unit.

- Read all instructions before using equipment.
- For your safety, the equipment is furnished with a properly grounded cord connector. Do not attempt to defeat the grounded connector.
- Install or locate the equipment only for its intended use as described in this manual. Do not use corrosive chemicals in this equipment.
- Do not operate this equipment if it has a damaged cord or plug, if it is not working properly, or if it has been damaged or dropped.
- This equipment should be serviced by qualified personnel only. Contact your nearest Authorized Service Agency for adjustment or repair.
- Do not block or cover any openings on the unit.
- Do not immerse cord or plug in water.
- Keep cord away from heated surfaces.
- Do not allow cord to hang over edge of table or counter.
- Turn the power off, unplug the power cord, and allow unit to cool down before performing any service or maintenance on the unit.
- The procedures in this manual may include the use of chemical products. These chemical products will be highlighted with bold face letters followed by the abbreviated HCS (Hazard Communication Standard). See Hazard Communication Standard manual for the appropriated Material Safety Data Sheets (MSDS).
- The equipment should be grounded according to local electrical codes to prevent the possibility of electrical shock. It requires a grounded receptacle with separate electrical lines, protected by fuses or circuit breaker of the proper rating.
- All electrical connections must be in accordance with local electrical codes and any other applicable codes.
- Do not clean this appliance with a water jet.

WARNINGS

Be advised of the following warnings when operating and performing maintenance on this unit.

- If the supply cord is damaged, it must be replaced by the manufacturer or its service agent or a similarly qualified person in order to avoid a hazard.
- Do not modify the power supply cord plug. If it does not fit the outlet, have a proper outlet installed by a qualified electrician.
- Do not use an extension cord with this appliance.
- Electrical ground is required on this appliance.
- Check with a qualified electrician if you are unsure if the appliance is properly grounded.
- If a chemical cleaner is used, be sure it is safe to use on cast aluminum. Observe all precautions and warnings on product label.
- Inspection, testing, and repair of electrical equipment should only be performed by qualified service personnel.
- This equipment is to be installed to comply with the basic plumbing code of the Building Officials and Code Administrators, Inc. (BOCA) and the Food Service Sanitation Manual of the Food and Drug Administration (FDA).
- To ensure proper steaming characteristics, some calcium/mineral deposits must be present on the generator surface. If, during cleaning, the surface does become free of calcium/mineral deposits, add plain tap water to the surface and allow it to boil off. This may have to be repeated several times to ensure proper steaming characteristics by creating a thin layer of deposits on the surface.
- Do not use a sanitizing solution or abrasive materials. The use of these may cause damage to the stainless steel finish.
- Chlorides or phosphates in cleaning agents (e.g. bleach, sanitizers, degreasers or detergents) could cause permanent damage to stainless steel equipment. The damage is usually in the form of discoloration, dulling of metal surface finish, pits, voids, holes, or cracks. This damage is permanent and not covered by warranty.

- The following tips are recommended for maintenance of your stainless steel equipment:
 - Always use soft, damp cloth for cleaning, rinse with clear water and wipe dry. When required, always rub in direction of metal polish lines.
 - Routine cleaning should be done daily with soap, ammonia detergent, and water.
 - Stains and spots should be sponged using a vinegar solution.
 - Finger marks and smears should be rubbed off using soap and water.
 - Hard water spots should be removed using a vinegar solution.

SPECIFICATIONS

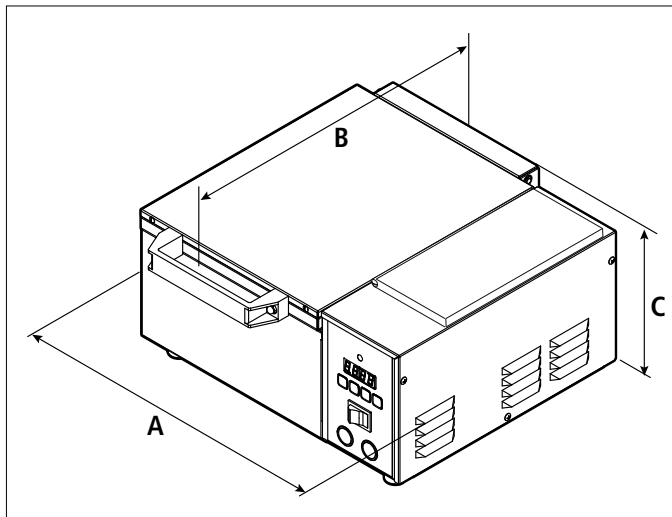

SHIPPING WEIGHT

DFW-150 Models 40 lbs (18.2 kg)

DFW-250 Models 40 lbs (18.2 kg)

CAPACITIES

DFW Series 2-7/8" (73 mm) deep half-size steam table pan

Model & Mfg. No.	Width (A)	Depth (B)	Height (C)
DFW-250 9100162	16 1/2" (419 mm)	17 1/8" (435 mm)	9" (229 mm)
DFW-150 9100165 9100169	16 1/2" (419 mm)	17 1/8" (435 mm)	9" (229 mm)

Model & Mfg. No.	Volts	Watts	Amps	Hertz	Plug Description
DFW-250 9100162	120~	1800	15	50/60	NEMA 5-15P 15 Amp., 120 Volt
DFW-150 9100165 9100169	120~	1800	15	50/60	NEMA 5-15P 15 Amp., 120 Volt

Model & Mfg. No.	Agency Approvals
DFW-250 9100162 DFW-150 9100165 9100169	

INSTALLATION

NOTE: When placing the unit, make sure to provide at least 3 inches of space on all sides of the unit.

1. Remove unit and all packing materials from shipping carton.
2. The unit should come with the items listed below:
 - Owner's Manual
 - Authorized Service Agency Directory

NOTE: If any parts are missing or damaged, contact Antunes Technical Service IMMEDIATELY at 1-877-392-7854 or 1-630-784-1000.

3. Remove all packing materials and protective coverings from the unit.
4. Remove and wash the Pan, False Bottom, and Pan Diffuser in soap and water. Rinse with clean water and allow to air dry.

NOTE: The steam generator surface will have a white coating of artificial lime deposits. This coating is necessary for steaming characteristics.

5. Wipe all surfaces of the unit with a hot damp cloth.

NOTE: Do NOT use a dripping wet cloth. Wring out before use.

6. Re-install Pan, False Bottom, and Pan Diffuser.

When placing the unit into service, pay attention to the following guidelines.

- Make sure to provide at least 3 inches of space on all sides of the unit.
- Make sure the power switch is off and the unit is at room temperature before plugging in the power cord.
- Do not block or cover any openings on the unit.
- Do not immerse the power cord or plug in water.
- Keep the power cord away from heated surfaces.
- Do not allow the power cord to hang over edge of table or counter.

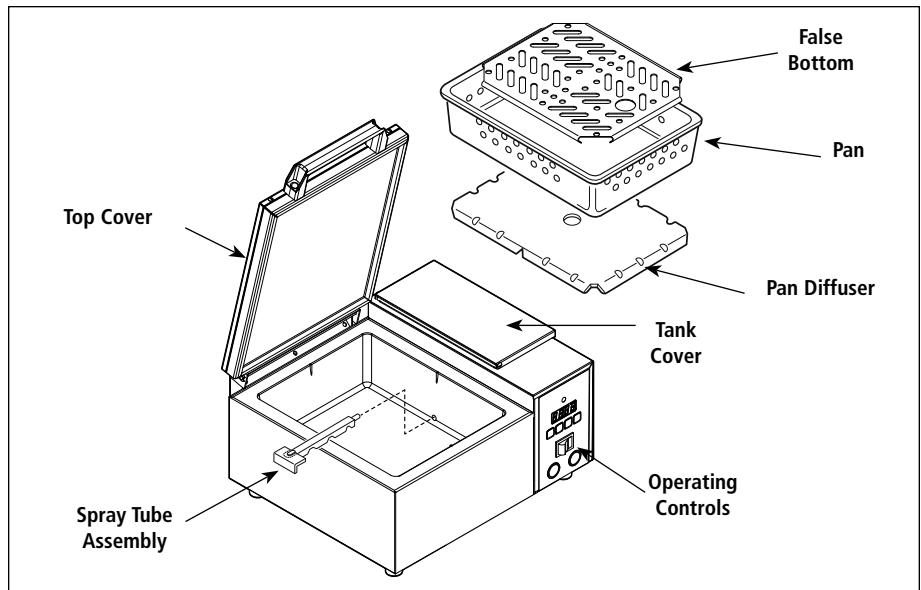

Figure 1. Components

ELECTRICAL

Plug the power cord into the appropriate power outlet. Refer to the specification plate for the proper voltage.

1. Place the unit on a sturdy, level table or other work surface.
2. Turn off the power.
3. Ensure that the line voltage corresponds to the stated voltage on the units specification label and power cord warning tag. If you are unsure of your Line Voltage, contact an electrician.
4. Connect the unit to the power supply.

⚠ WARNING ⚠

Be sure to follow all the precautions, procedures, and safety steps listed in the Important Safety Information section of this manual.

⚠ WARNING ⚠

All electrical connections must be in accordance with local electrical codes and any other applicable codes.

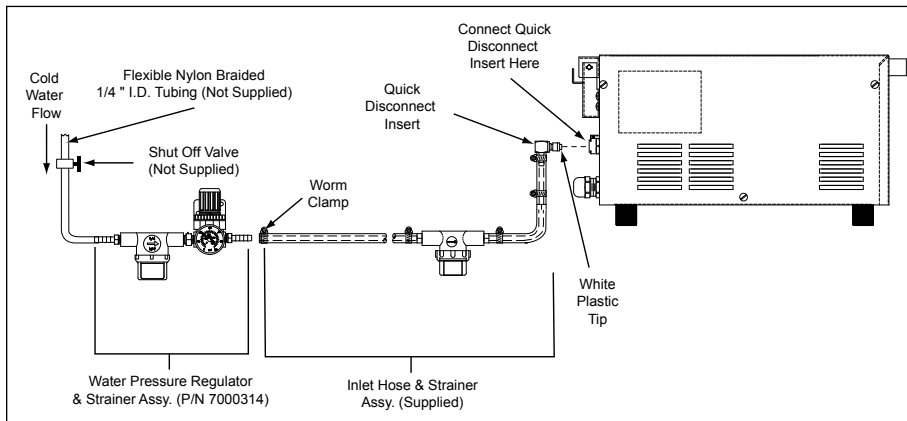

Figure 2. Connecting Water Supply to DFW-250

PLUMBING

DFW models are designed to use cold tap water. Distilled water may be used to reduce calcium/mineral deposit buildup and reduce maintenance costs.

DFW-150 MODELS

The DFW-150 models have a self-contained water tank. To fill the tank:

1. Open the tank cover (Figure 1) on the top of the unit.

NOTE: Make sure the filter inside the tank is installed properly.

2. Pour in cold tap water. The tank will hold approximately 3 quarts (2.81 liters). Do not overfill the tank.
3. Close the tank cover.

NOTE: Allow top cover to remain open overnight. We recommend emptying the unit of water overnight. Do not leave unit filled with water overnight.

DFW-250 MODELS

The DFW-250 models require a direct cold water hookup. A water inlet hose and strainer assembly (Figure 2) is supplied.

Incoming water is controlled by a normally closed solenoid valve located inside the steamer's electrical housing.

1. Turn off the water valve (not supplied) that provides water to the unit.
2. Connect the 1/4" (6.5 mm) ID flexible tubing to the outlet side of the water pressure regulator and secure using the worm clamp.

NOTE: A Water Pressure Regulator must be installed. Failure to do so will result in poor steaming and possible flooding. For a single steamer, use Water Pressure Regulator P/N 7000314. For two adjacent steamers, use Water Pressure Regulator P/N 7000235.

3. Turn the water valve on.
4. Over a bucket, press and hold the white plastic tip on the Quick Disconnect Insert (Figure 2) until a good, steady water flow is noted (this will purge all air out of the line).
5. Release the plastic tip and check the pressure on the Water Pressure Regulator. It should read 20 psi.
 - a.) If it reads less, increase the water pressure by pulling the black knob up and turning it clockwise.
 - b.) If it reads more, decrease the water pressure by pulling the black knob up and turning it counter clockwise.

NOTE: When adjusting the knob, you must relieve the existing pressure by pressing the plastic tip on the Quick Disconnect Insert for 3 seconds. This allows the newly set pressure to register on the gauge. Repeat this until the gauge reads 20–25 psi.

6. Once the regulator reads 20 psi, push the black knob down to lock it in place.
7. Push the Quick Disconnect Insert into the fitting at the rear of the unit until it clicks (Figure 2).

CAUTION

Water pressure must not exceed 30 psi (2.1 kg/cm² or 207 kPa). Higher water pressures may cause poor performance or flooding. To reduce water pressure, install a water pressure regulator, and set water pressure to 20–25 psi (1.4–1.7 kg/cm² or 138–172 kPa).

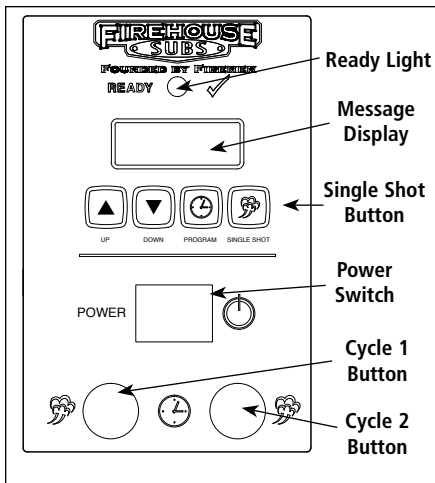

Figure 3. Operating Controls

OPERATING INSTRUCTIONS

1. Turn the power on.
2. Allow the unit to preheat for approximately 30 minutes.

NOTE: The flashing green Ready Light will become steady when the unit is warmed up and ready to use.

NOTE: Do NOT push the CYCLE buttons during warm-up.

3. Open the top cover and place the product to be steamed onto the False Bottom, then close the cover.
4. **Timed Cycle:** Press the **CYCLE 1** or **CYCLE 2** button to begin the steaming cycle. Display will count down to zero.
5. **OPTIONAL: Single Shot:** Press the **SINGLE SHOT** button and wait for the steam to penetrate the product.

NOTE: This unit is designed to use the **CYCLE 1** or **CYCLE 2** button for steaming. The **SINGLE SHOT** button should be used only in special circumstances.

6. Remove steamed product.

⚠ WARNING ⚠

To avoid injury, be careful when opening top cover. Be sure to allow steam to escape before putting hands or face over the steamer.

PROGRAMMING

CYC (Total Cycle Time) refers to the total programmed steam time set for the product.

SHO (Shot Interval Time) refers to the time set between shots of steam during a complete cycle.

H2O setting (Steam Shot Time) refers to the water volume consumed during each water pump activation.

The amount of steam produced by your Deluxe Food Warmer depends on the amount of water sprayed onto the steam generator.

Flooding of the generator may occur if the H2O setting is too high. To prevent flooding, the Shot Interval Time (SHO) can be increased to allow more time for generator heat recovery. Adjustments should be made to both values to determine the best settings for your cooking needs.

1. Turn the unit on. The unit displays "IDLE".
2. Press and release the Program button to change the control from OPERATION to PROGRAM mode.
3. The display shows "1 or 2". Press the desired cycle button to select the channel to be programmed.
4. To change the Total Cycle Time (CYC) in minutes, press ▲ or ▼ to change the time.
5. Press and release the Program button again, and press ▲ or ▼ to change the Total Cycle Time in seconds.
6. To change the SHO factory settings, make sure the control is in PROGRAM mode, then press and hold both ▲ and ▼ simultaneously for 1-2 seconds and release. "SHO" will be displayed.
7. Press and release the Program button and then press ▲ or ▼ to change the SHO in seconds.

NOTE: Refer to Table 1 for the recommended settings for your unit.

8. Press and release the Program button again and press ▲ or ▼ to change the SHO in minutes.

NOTE: Refer to Table 1 for the recommended settings for your unit.

9. Press and release the Program button again and "H2O" will be displayed.
10. To change the H2O (Steam Shot time), press and release the Program button again to display the setting. Use ▲ or ▼ to increase or decrease the time.

NOTE: Refer to Table 1 for the recommended settings for your unit.

11. Press the Start/Stop or Cycle buttons to store the changes, exit the PROGRAM Mode, and initiate the cooking cycle.

NOTE: The Start/Stop or Operate buttons may be pressed at any time during programming to store the changes and exit the PROGRAM Mode.

NOTE: If a change is not made within 5 seconds at any time during the programming process, all changes made up to that point are stored in memory and the control reverts to the OPERATION Mode.

RECOMMENDED SETTINGS

Mfg. No.	CYC	SHO	H2O
9100162	2 min., 45 sec.	15 sec., 0 min.	0_50
9100165	2 min., 45 sec.	15 sec., 0 min.	0_80
9100169 (Cycle 1)	2 min., 45 sec.	15 sec., 0 min.	0_80
9100169 (Cycle 2)	1 min., 45 sec.	15 sec., 0 min.	0_80

Table 1. Recommended Settings

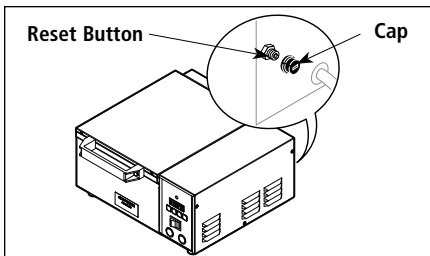

Figure 4. Hi-Limit Reset Button

HI-LIMIT RESET BUTTON

A hi-limit thermostat will turn off electrical power to the heater and control circuits if the unit overheats. To reset the thermostat, allow sufficient time (about 45 minutes) for the unit to cool down, remove the cap and press the red reset button located on the rear of the unit (Figure 4).

If the unit requires continuous resetting, contact your Authorized Service Agency.

FAULT CODES

When the programming parameters for Minutes, Seconds, SHO, or H2O have been inadvertently changed to a setting above or below their limits, the unit displays the "ERR" fault code. If this fault code appears, you must clear these settings using the following procedure.

For units with Mfg. No. 9100165 or 9100169:

1. Turn the power off.
2. Press and hold the **SINGLE SHOT** and **PROGRAM** buttons simultaneously.
3. Turn the unit on while holding the buttons. Release the buttons when the unit stops beeping.

NOTE: Repeat steps 1 through 3 if the unit still displays the "ERR" fault code.

4. The display will now register 2:45.

For units with Mfg. No. 9100162:

1. Turn the power off.
2. Press and hold the **UP Arrow** and **DOWN Arrow** buttons simultaneously.
3. Turn the unit on while holding the buttons. Release the buttons when the unit stops beeping.

NOTE: Repeat steps 1 through 3 if the unit still displays the "ERR" fault code.

4. The display will now register 2:45.

NOTE: The SHO and H2O settings should be adjusted to the recommended settings shown in the Programming section of this manual.

DIAGNOSTIC LEDS

This control board has 4 diagnostic LEDs described below.

Green (Program): When lit, indicates the unit is in PROGRAM mode.

Yellow (Audio): When lit, indicates 10-15 VDC is being supplied to the audio signal. The audio signal will sound and the LED will be lit for approximately 3 seconds.

Red (Heat): When lit, indicates the unit is calling for heat by supplying 10-15 VDC to the solid state relay. When off, indicates the generator surface is up to temperature.

Green (H2O): When lit, indicates that 24 VAC is being supplied to operate the solenoid valve used in DFW-250 units or to the water pump used in the DFW-150 units.

NOTE: This LED is only lit for approximately 1 second.

DAILY MAINTENANCE

NOTE: Frequency of cleaning is determined by water conditions, usage and water filter systems.

1. Turn the power off, unplug the power cord, and allow the unit to cool down before proceeding.
2. Check the water pressure regulator gauge (DFW-250 only) and verify that it reads 20–25 psi (1.4–1.7 kg/cm² or 138–172 kPa). If not, adjust the water pressure as described in the Installation section of this manual. Check the rear water Quick Disconnect Fitting and Hose Clamp for leakage. Tighten clamps or replace parts if needed.
3. Remove the False Bottom, Pan, and Pan Diffuser (Figure 5).
4. Wash these items in hot, soapy water and then rinse and wipe dry.
5. Wipe down the Top Cover and the entire exterior of the unit (Figure 5) with a clean, hot, damp cloth (not dripping wet) and wipe dry.
6. Re-install Pan Diffuser, Pan, and False Bottom.
7. Remove water from the water tank using a cup.

NOTE: Allow top cover to remain open overnight. We recommend emptying the unit of water overnight. Do not leave unit filled with water overnight.

NOTE: Failure to properly clean and dry the above mentioned items may result in the accumulation of water/moisture overnight. This may lead to permanent damage to the equipment's finish and its accessories. This damage is not covered by warranty.

⚠ CAUTION ⚠

Do not use a sanitizing solution or abrasive materials. The use of these may cause damage to the stainless steel finish.

⚠ CAUTION ⚠

If a chemical cleaner is used, be sure it is safe to use on cast aluminum. Observe all precautions and warnings on product label.

⚠ WARNING ⚠

Turn the power off, unplug the power cord, and allow the unit to cool down before performing any service or maintenance.

⚠ WARNING ⚠

Be sure to follow all the precautions, procedures, and safety steps listed in the Important Safety Information section of this manual.

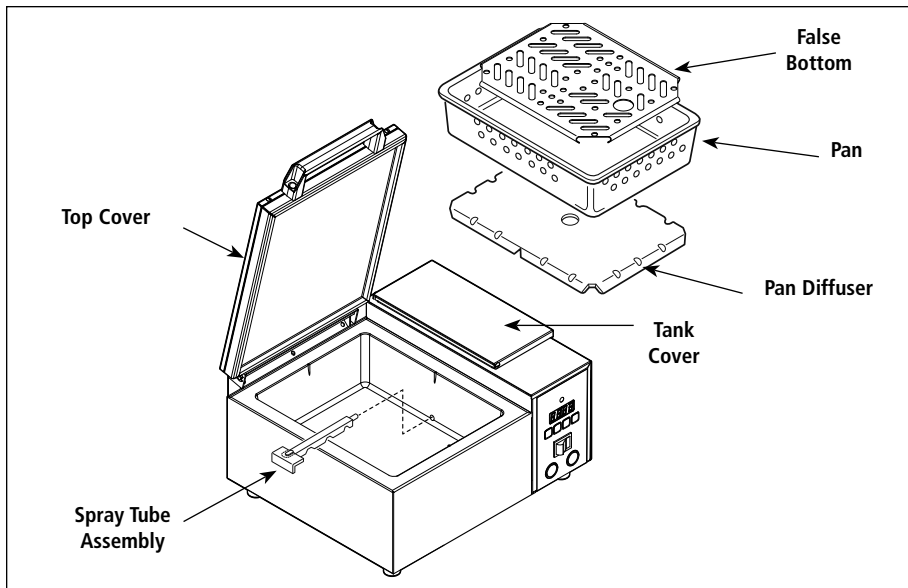

Figure 5. Components (DFW-150 Shown)

MONTHLY MAINTENANCE

CLEAN SPRAY TUBE AND STEAM GENERATOR

The Deluxe Food Warmer utilizes an open Steam Generator. Water sprayed onto the generator surface flashes into steam immediately, but the minerals in the water do not steam. They stay on the generator surface. A small amount of calcium/mineral deposits are needed for proper operation, but a buildup of excessive calcium/mineral deposits causes poor steaming efficiency and excessive moisture (wet steam), which will eventually severely retard the steaming action.

1. Turn the power off, unplug the power cord, and allow the unit to cool down before proceeding.
2. Perform the Daily Cleaning, but do not reassemble the unit.
3. Remove the Spray Tube (Figure 5) by lifting the loose end and pulling it out of the generator hole.
4. Slide the metal cover off of the spray tube, take a paper clip and clear out all of the tube's holes.
5. Gently wash the tube under running water to clear the deposits out of the loose end. Reattach the cover onto the tube.

NOTE: Do not bend the spray tube. Any bends in the tube will result in permanent damage.

6. Use a scraper or spatula to remove the excessive calcium/mineral buildup from the generator surface (Figure 6).
7. Thoroughly wipe the generator with a damp cloth to remove any loose buildup and reassemble the unit.

NOTE: If deposits are still excessive and/or difficult to remove, refer to Steps 1 through 6 below.

1. Pour delimer solution (not supplied) onto the generator surface. Follow the delimer manufacturer's instructions for proper mixture and use.
2. Using a sponge or a dry towel, remove the delimer solution from the generator surface and then rinse the surface with clean water.

To ensure proper steaming characteristics, some calcium/mineral deposits must be present on the generator surface. If, during cleaning, the surface does become free of calcium/mineral deposits, add plain tap water to the surface and allow it to boil off. If necessary, repeat this process to formulate a thin coating of calcium/mineral deposits.

In soft water areas, it may be necessary to add a small amount of lime to the generator surface to season it. This will ensure proper steaming characteristics by producing a thin coating of calcium/mineral deposits on the Generator surface.

Seasoning mixture consists of 3/4 ounces (25 ml/25 cc) baking soda, 3/4 ounces (25 ml/25 cc) lime mixed with 1 quart (950 ml/950 cc) of water. Stir mixture and pour 1/4" deep onto the hot Generator surface. After mixture is converted to steam, the remaining loose powder can be removed.

3. Plug the power cord into the appropriate outlet.
4. Turn the power on and allow the unit to warm up for approximately 30 minutes.
5. Push and release the **CYCLE** button several times to purge any remaining delimer residue from the generator surface.
6. Turn the power off, reinstall all parts and accessories, and return the unit to service.

MONTHLY MAINTENANCE

WATER TANK FILTER (DFW-150 ONLY)

The water tank filter is used to prevent particles or food products from entering and damaging the water pump. Inspect and clean this filter monthly or more regularly using the following procedure.

1. Turn the power off, unplug the power cord, and allow the unit to cool down before proceeding.
2. Open the tank cover (Figure 6).
3. Remove the water tank filter, located inside the tank, by pulling it upwards and out of the bottom hole.
4. Clean the filter by running it under tap water. Replace the water tank filter if the screen is torn or damaged.
5. Reinstall the filter stem into the bottom hole of the tank (Figure 6).
6. Fill the water tank and test the unit.

WATER STRAINER (DFW-250 ONLY)

The water strainer protects your equipment from any foreign debris in the water line that could damage the unit's solenoid (causing the unit to leak/flood). To ensure proper and consistent steaming results, check the water pressure regulator and strainer cup regularly. If the pressure on the gauge has dropped, check the strainer cup and clean out the accumulated debris as follows:

1. Shut off the water supply valve to the unit, unscrew the strainer cup, and carefully remove the mesh strainer screen.
2. At the sink, gently flush all of the accumulated debris from the strainer cup and mesh strainer screen. Be especially careful not to damage the mesh strainer screen.
3. Carefully place the mesh strainer screen into its seat at the bottom of the strainer cup and confirm that the orange O-ring is properly seated in its place before screwing the strainer cup and top back together.
4. Purge the air out of the strainer and tubing by disconnecting the male quick disconnect insert from the equipment and, over a bucket, push the white plastic tip in until there is good water flow.
5. Replace damaged or worn parts.
6. Verify that the water pressure regulator is set to 20–25 psi (1.4–1.7 kg/cm² or 138–172 kPa).

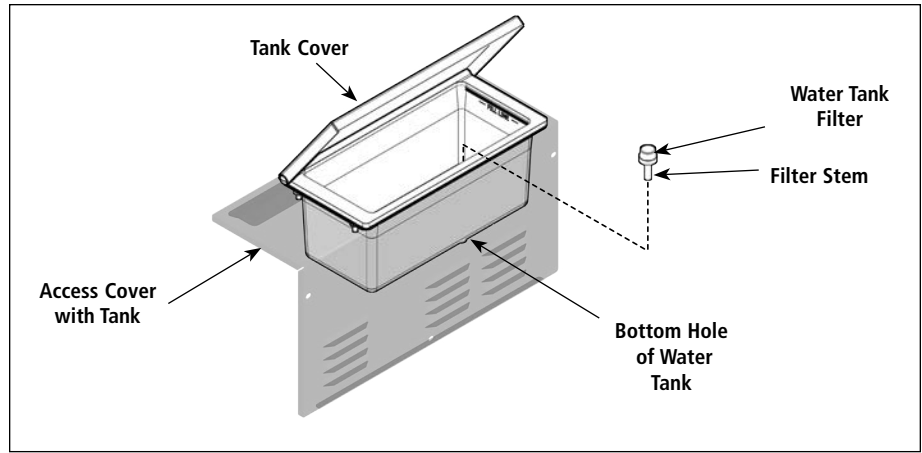

Figure 6. Water Tank Filter

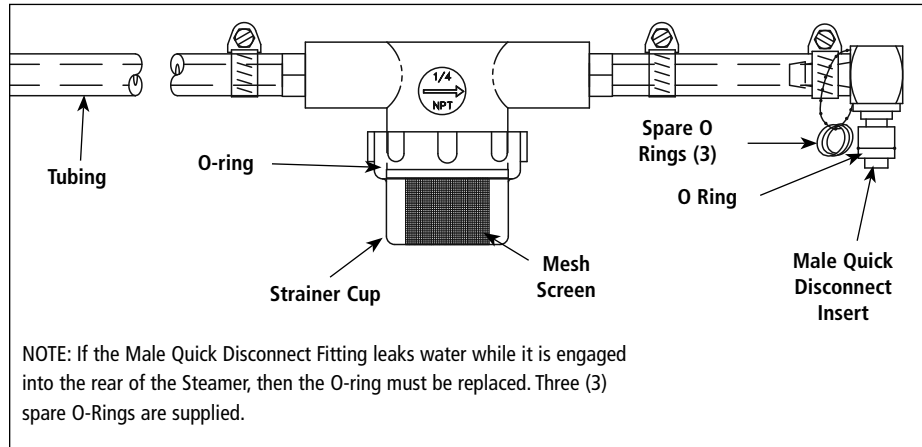

Figure 7. Inlet Hose Assembly

TROUBLESHOOTING

⚠ WARNING ⚠

To avoid possible personal injury and/or damage to the unit, inspection, test, and repair of electrical equipment should be performed by qualified service personnel. The unit should be unplugged when servicing, except when electrical tests are required. Use extreme care during electrical circuit tests. Live circuits will be exposed. If the troubleshooting steps listed below do not solve your machine's problem, contact an Authorized Service Agency for further assistance.

Problem	Possible Cause	Corrective Action
Control Display is blank (Power is on but indicator light is off).	The power cord is not correctly plugged in.	Plug the power cord into the appropriate outlet.
	The power cord and/or electrical plug is damaged.	Inspect electrical wire, plug, and receptacle.
	The main electrical panel circuit breaker is off or has tripped.	Reset circuit breaker. Contact your maintenance person or Authorized Service Agency if it trips again.
	Power Switch is inoperable.	Contact your maintenance person or Authorized Service Agency for service.
Control Display is blank (Power is on and indicator light is on).	Control Board is inoperable.	Contact your maintenance person or Authorized Service Agency for service.
	Transformer is inoperable.	
	Loose, burnt, or broken wires in circuit.	
Unit does not heat up (Power is on and indicator light is on).	Hi-Limit Thermostat is tripped or inoperable.	Reset the Hi-Limit Thermostat according to the Operation section of this manual. If the Hi-Limit Thermostat requires continuous resetting, contact your Authorized Service Agency for service.
	Transformer is inoperable.	
	Solid State Relay is inoperable.	
	Thermocouple is inoperable.	
	Control Board is inoperable.	
	Steam Generator is inoperable.	
	Loose, burnt, or broken wires in circuit.	
The unit's main electrical panel circuit breaker trips.	Damaged receptacle, plug, or cord; a loose connection; or an internal component failure.	Turn the unit off, allow it to cool to room temperature, and then restart the unit. Contact your maintenance person or Authorized Service Agency if the condition repeats.
	Circuit breaker is overloaded.	
Water leaking inside electrical housing.	Pinhole leak in robber hoses.	Replace hoses.
	Loose or damaged water line tubes and/or fittings inside electrical housing.	Tighten or replace tubes and/or fittings.
"ERR" appears on the Control Display.	Programming and/or SHO and H2O values were adjusted/changed improperly.	Reset the Control Board as described in the Programming section of this manual. See Fault Codes.

TROUBLESHOOTING (continued)

Problem	Possible Cause	Corrective Action
Unit heats but there is little or no steam produced and/or the product requires more steaming than usual.	Filter Strainer and/or Spray Tube is restricted.	Check and clean the Filter Strainer and Spray Tube as described in the Maintenance section of this manual.
	Unit is not being cleaned properly (daily/monthly).	Clean the unit daily and monthly as described in the Maintenance section of this manual.
	Programming and/or SHO , H2O values were adjusted/changed improperly.	Reprogram the SHO and H2O values as described in the Programming section of this manual.
	Insufficient or excessive calcium/mineral deposits on the Generator Surface.	Verify that a thin layer of calcium/mineral deposits is present on the Generator Surface. Refer to the Maintenance section of this manual.
	Generator Surface is bare.	The Generator Surface must have a thin coating of calcium/mineral deposits for proper steaming. Refer to the Maintenance section of this manual.
	The Water Pump's rubber hoses are pinched or kinked.	Straighten and reposition the rubber hoses.
	Top Cover Gasket is worn and/or cover is out of adjustment.	If noticeable steam escapes around the Top Cover, replace the gasket and/or adjust the Top Cover according to the Maintenance section of this manual.
	Generator Diffuser is missing.	Install Generator Diffuser or replace if missing.
	Generator Surface temperature is too low.	Verify that the Generator Surface temperature is 405°F - 445°F (207°C - 229°C).
Excessive condensation in food compartment.	Programming and or SHO and H2O values were adjusted improperly.	Reprogram the SHO and H2O values as described in the Programming section of this manual.
Steam Generator's surface becomes flooded (fills with excess water).	Insufficient preheat time.	Remove excess water from the Generator Surface and allow the unit to preheat for 30 minutes.
	Programming and/or SHO and H2O values were adjusted or changed improperly.	Reprogram the Control Board to the recommended settings. Refer to the Programming section of this manual.
	The Water Pump and/or its Check Valves are clogged or damaged.	Verify that the Filter is present in the Water Tank. Disassemble and clean the pump. Replace Check Valves if damaged.
	Improper Daily/Monthly cleaning.	Follow the Daily/Monthly cleaning procedures carefully.
	The Generator Surface temperature is too low.	Verify that the Generator Surface temperature is 405°F - 445°F (207°C - 229°C).
	Insufficient or excessive calcium/mineral deposits on the Generator Surface.	Verify that a thin layer of calcium/mineral deposits is present on the Generator Surface. Refer to the Maintenance section of this manual.

REPLACEMENT PARTS

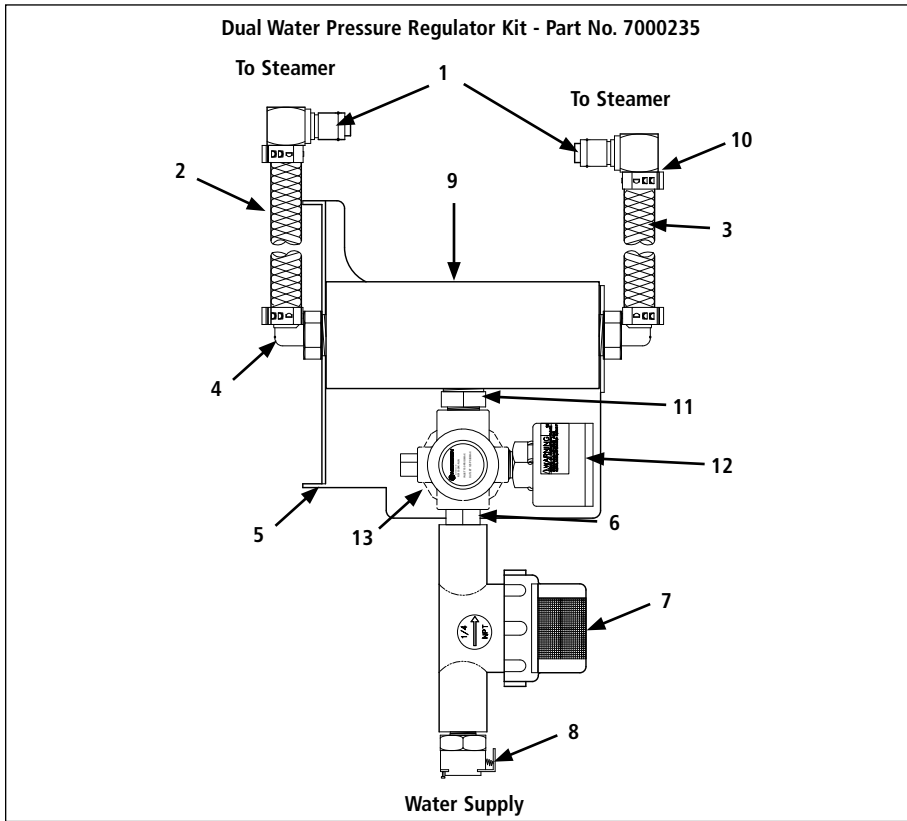

Item	Part No.	Description	Qty.
1	7000139	Elbow, Quick Disconnect - 1/4"	2
2	2030126	Tubing 1/4" I.D. PVC BRD. 24" Long	1
3	2030125	Tubing 1/4" I.D. PVC BRD. 12" Long	1
4	2040150	Elbow, Male - Nylon 1/4" Barb x 3/8" NPT	2
5	0503615	Bracket, Manifold Mtg.	1
6	2190129	Nipple 1/4" NPT x 1/4" NPT	1
7	7000333	Strainer - 1/4" FPT	1
8	2080118	Quick Disconnect - 1/8" NPT	1
9	2190113	Manifold	1
10	211P104	Clamp, Ear Med.	4
11	2040151	Nipple, Hex - 3/8" x 1/4" NPT Nylon	1
12	7000306	Gauge, Water Pressure	1
13	2170113	Regulator, Pressure	1

IMPORTANT: Two adjacent steamers can be fed with a Dual Water Pressure Regulator.

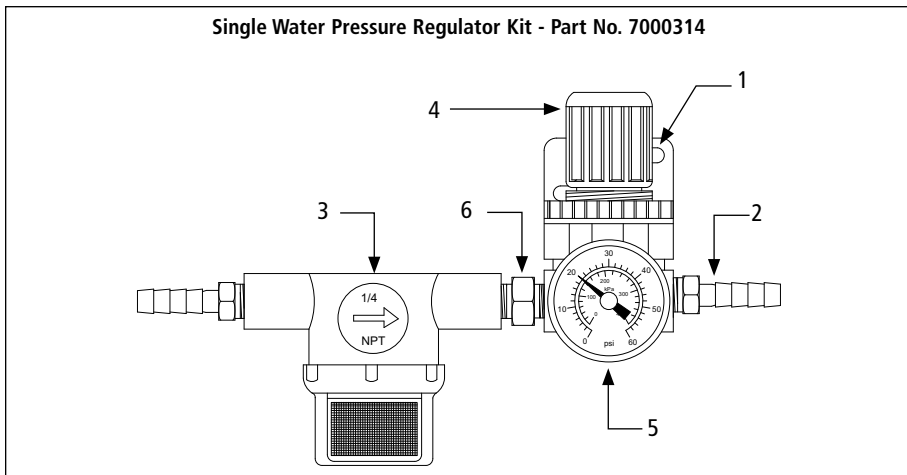

Item	Part No.	Description	Qty.
1	0503849	Bracket	1
2	2040130	Male Adapter, Barbed 1/4"	2
3	See Below for Strainer Parts Identification		
4	2170113	Regulator, Pressure	1
5	7000306	Gauge, Water Pressure	1
6	2190129	Nipple 1/4" NPT x 1/4" NPT	1
7	211P104	Clamp, Worm (not shown)	2

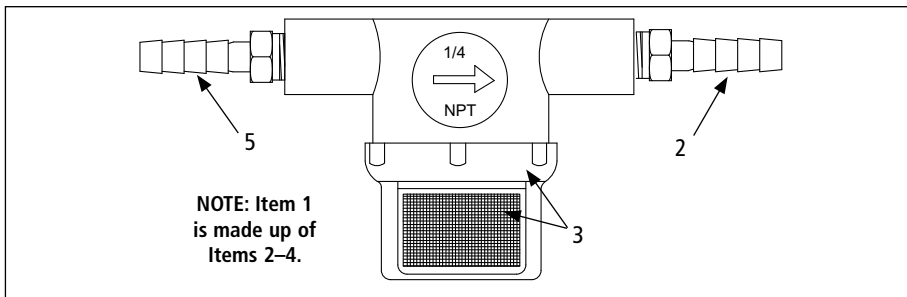

Item	Part No.	Description	Qty.
1	7000333	Water Line Strainer Kit	1
2	2040130	Male Adapter, Barbed 1/4"	2
3	7000334	Replacement Screen and O-ring Kit	1
4	211P104	Clamp, Worm (not shown)	2

REPLACEMENT PARTS (continued)

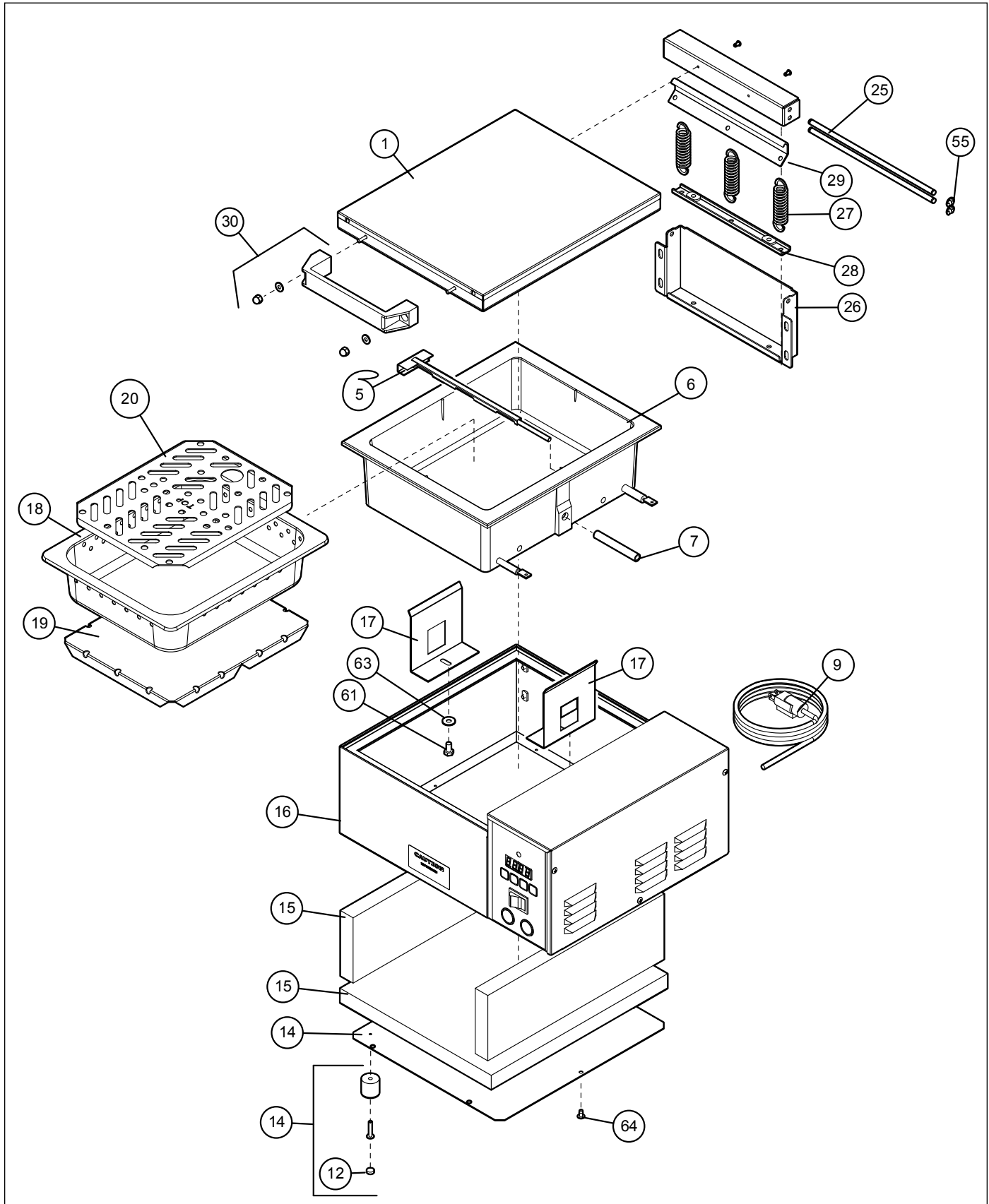

REPLACEMENT PARTS (continued)

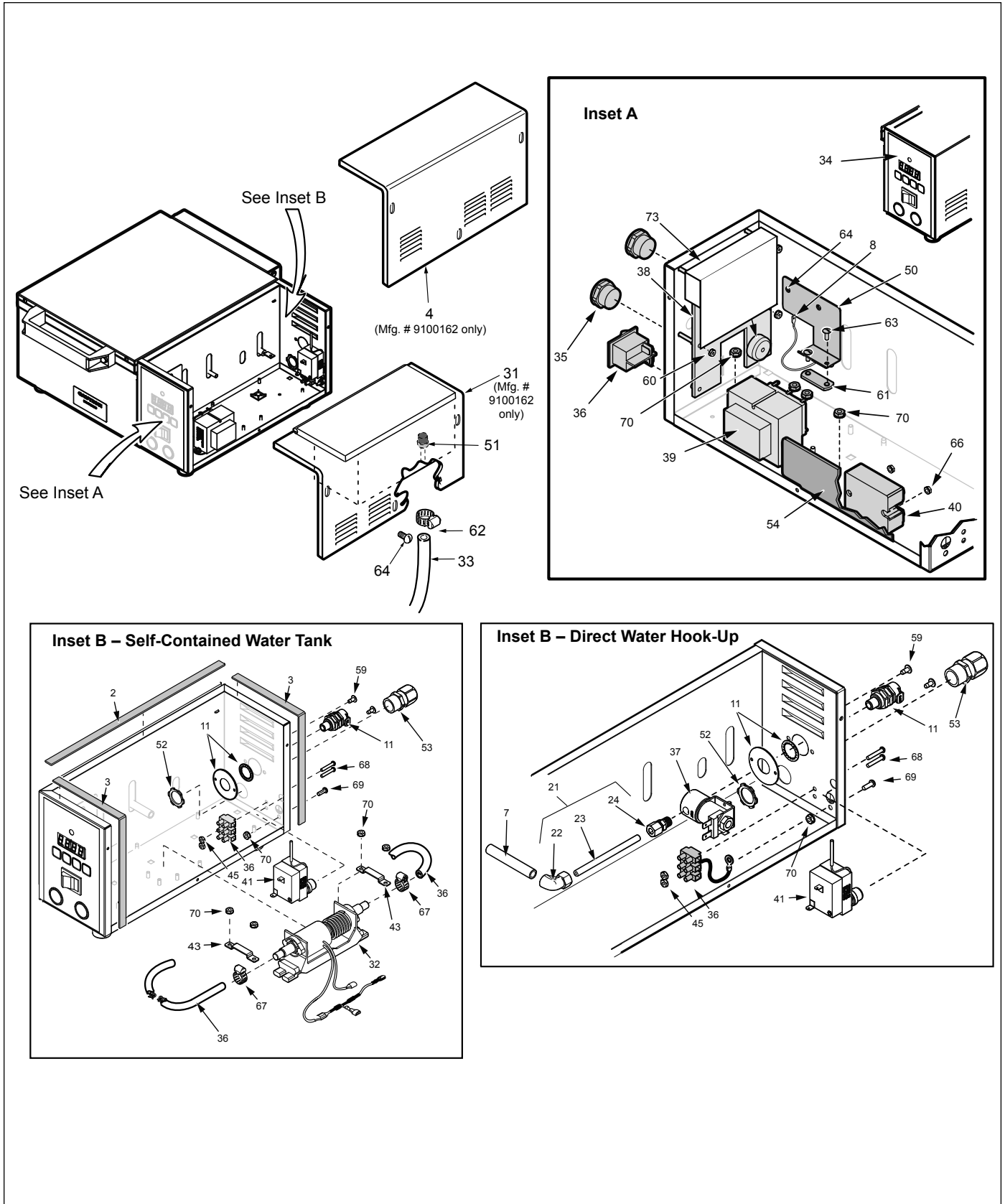

REPLACEMENT PARTS (continued)

Item	Part No.	Description	Qty.
1	0012856	Top Cover Assy.	1
2	0200315	Gasket, Cross Over Access Cover	1
3	0200316	Gasket, Side, Access cover	2
4	0506433	Access Cover Assy. (DFW-250 only)	1
5	0010145	Spray Tube Assembly	1
6	7000124	Steam Generator, 120 VAC 1800 W	1
7	7000448	Tube Replacement Kit	1
8	4050209	Thermocouple	1
9	0700463	Power Cord, 120 VAC, 14/3 5-15P	1
10	7000139	Quick Disconnect, Male	1
11	7000138	Quick Disconnect Body & Plate Kit	1
12	218P145	Cover, Leg	1
13	210K230	Leg, 1" (Pack of 4)	1
14	0506433	Base Plate	1
15	7000131	Insulation Kit	1
16	0012862	Main Housing	1
	0013718	Main Housing (Mfg. No. 9100169)	1
17	0503174	Retainer, Generator	2
18	2130102	Perforated Pan	1
19	0503177	Diffuser Pan	1
20	0504652	False Bottom	1
21	7000142	Outlet Tube Kit (Incl. Nos. 22, 23 & 24)	1
22	204P114*	Elbow, Female, 1/4" Tube	1
23	2000188	Outlet Tube	1
24	2040103	Connector, Male, 1/4" Tube	1
25	0800280	Hinge Pin	1

Item	Part No.	Description	Qty.
26	0502719	Hinge Base	1
27	0600125	Spring	3
28	0020952	Hinge Beam	1
29	0502722	Pivot Bracket	1
30	7000718	Handle Kit	1
31	0012858	Access Cover Assy.	1
32	404K107	Pump Diode Assy.	1
33	7000849	Silicone Tube Kit (Incl. 2 tubes)	1
34	1001462	Label, Front Panel	1
	1001584	Label, Front Panel (Mfg. No. 9100169)	1
35	4010243	Cycle Switch	1
36	7000882	Rocker Switch (power) Sealed	1
37	4040145	Solenoid, 24 VAC	1
38	7001284	Control Board Kit	1
39	7000319	Transformer	1
40	4050231	Relay, Solid State	1
41	7000135	Hi-Limit Thermostat	1
42	7000136	Terminal Block Kit	1
43	0506441	Bracket, Pump Mounting	2
44	7000850	Water Pump Kit, 24 VAC 1 (Incl. No. 32 & 33)	1
45	7000142	Outlet Tube Kit (Incl. Nos. 46 & 47)	1
46	204P114*	Elbow, Female, 1/4" Tube	1
47	2000188	Outlet Tube	1
48	306P101*	Nut, Hex #06-32 SS	1

Item	Part No.	Description	Qty.
49	7000156	Audio Alarm Kit	1
50	0503333	Bracket, Temperature Sensor	1
51	0010159	Filter Assy., Water Tank	1
52	040P138*	Locknut, Conduit, 1/2"	1
53	040K251	Strain Relief	1
54	0505699	Relay Heat Sink	1
55	211P127*	Retaining Ring	1
56	325P109*	Screw, Hex	1
57	325P154*	Lockwasher	1
58	325P104*	Washer, Flat	1
59	308P157*	Scr, Tap #08-32 X 3/8 PHTRSHD;"F"; 410 S/S	1
60	304P105*	Nut, Hex, #4-40 KEPS	1
61	301P106*	Nut, Spotweld, #6-32	1
62	211P101*	Hose Clamp, 3/8" Dia.	1
63	306P103*	Screw, #6-32 x 3/8", SS	1
64	308P103*	Screw, #8-32 x 1/4", SS	1
65	308P164*	Screw, #8-32 x 1", SS	1
66	306P130*	Nut, Hex, #6-32 KEPS	1
67	211P195*	Hose Clamp, 1/2" Dia.	1
68	306P123*	Screw, #6-32 x 7/8", SS	1
69	308P124*	Screw, #8-32 x 1/2", 1-Way, SS	1
70	308P143*	Nut, Hex, #8-32 KEPS	1
72	406P107*	Cable Tie	1
73	0400472	Moisture Cover, DFW	1

* Only available in packages of 10.

WIRING DIAGRAM

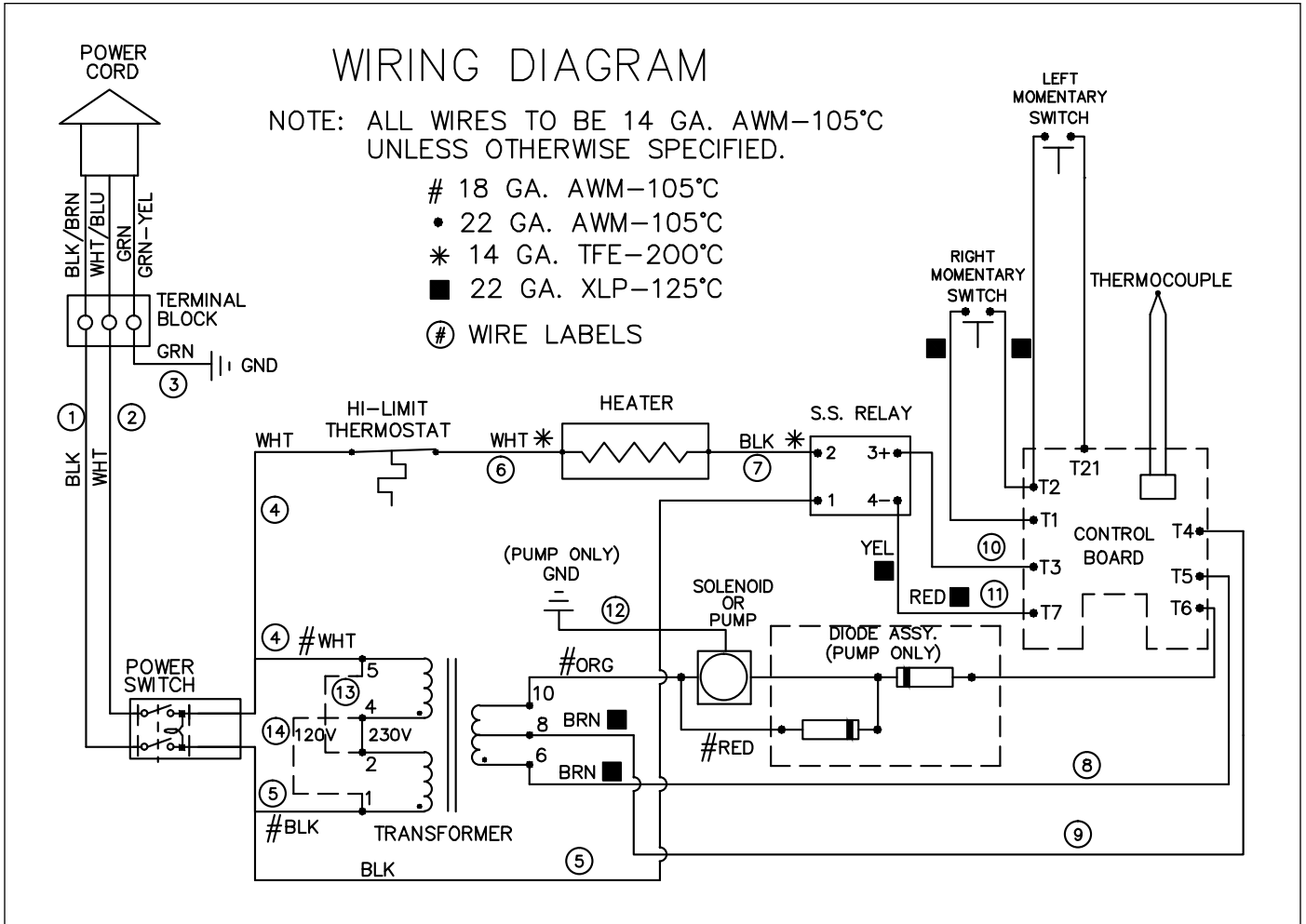

For DFW-150 Mfg. No. 9100169

WIRING DIAGRAM (continued)

WIRING DIAGRAM

NOTE: ALL WIRES TO BE 14 GA. AWM-105°C UNLESS OTHERWISE SPECIFIED.

18 GA. AWM-105°C

• 22 GA. AWM-105°C

⊙ WIRE LABELS

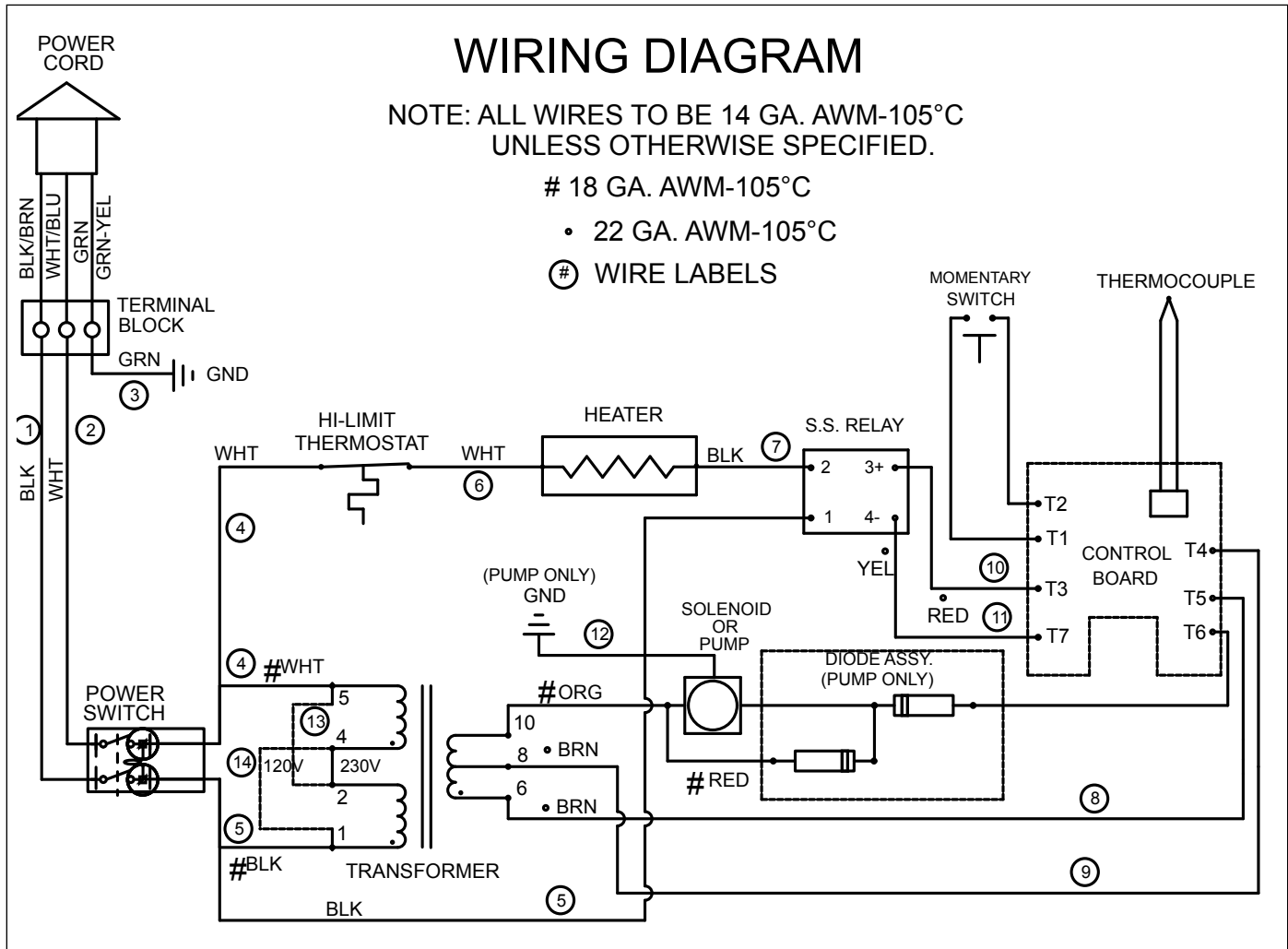

For DFW-150 Mfg. No. 9100165 and DFW-250 Mfg. No. 9100162

LIMITED WARRANTY

Equipment manufactured A.J. Antunes & Co. has been constructed of the finest materials available and manufactured to high quality standards. These units are warranted to be free from electrical and mechanical defects for a period of one (1) year from date of purchase under normal use and service, and when installed in accordance with manufacturer's recommendations. To insure continued operation of the units, follow the maintenance procedures outlined in the Owner's Manual. During the first 12 months, electro-mechanical parts, non-overtime labor, and travel expenses up to 2 hours (100 miles/160 km), round trip from the nearest Authorized Service Center are covered.

1. This warranty does not cover cost of installation, defects caused by improper storage or handling prior to placing of the Equipment. This warranty does not cover overtime charges or work done by unauthorized service agencies or personnel. This warranty does not cover normal maintenance, calibration, or regular adjustments as specified in operating and maintenance instructions of this manual, and/or labor involved in moving adjacent objects to gain access to the equipment. This warranty does not cover consumable/wear items. This warranty does not cover damage to the Load Cell or Load Cell Assembly due to abuse, misuse, dropping of unit/shock loads or exceeding maximum weight capacity (4 lbs). This warranty does not cover water contamination problems such as foreign material in water lines or inside solenoid valves. It does not cover water pressure problems or failures resulting from improper/incorrect voltage supply. This warranty does not cover Travel Time & Mileage in excess of 2 hours (100 miles/160 km) round trip from the nearest authorized service agency.
2. Antunes reserves the right to make changes in design or add any improvements on any product. The right is always reserved to modify equipment because of factors beyond our control and government regulations. Changes to update equipment do not constitute a warranty charge.
3. If shipment is damaged in transit, the purchaser should make a claim directly upon the carrier. Careful inspection should be made of the shipment as soon as it arrives and visible damage should be noted upon the carrier's receipt. Damage should be reported to the carrier. This damage is not covered under this warranty.
4. Warranty charges do not include freight or foreign, excise, municipal or other sales or use taxes. All such freight and taxes are the responsibility of the purchaser.
5. THIS WARRANTY IS EXCLUSIVE AND IS IN LIEU OF ALL OTHER WARRANTIES, EXPRESSED OR IMPLIED, INCLUDING ANY IMPLIED WARRANTY OR MERCHANTABILITY OR FITNESS FOR A PARTICULAR PURPOSE, EACH OF WHICH IS HEREBY EXPRESSLY DISCLAIMED. THE REMEDIES DESCRIBED ABOVE ARE EXCLUSIVE AND IN NO EVENT SHALL ROUNDUP BE LIABLE FOR SPECIAL CONSEQUENTIAL OR INCIDENTAL DAMAGES FOR THE BREACH OR DELAY IN PERFORMANCE OF THIS WARRANTY.



Corporate Headquarters	China Facility
Carol Stream, Illinois	Suzhou, China
Phone: +1 (630) 784-1000	Phone: +86-512-6841-3637
Toll Free: +1 (800) 253-2991	Fax: +86-512-6841-3907
Fax: +1 (630) 784-1650	