

Horizontal Contact Toaster

Model HCT-2000 owner's manual

Manufacturing Numbers:

9210322



Table of Contents

General	2
Warranty Information.....	2
Service/Technical Assistance.....	2
Important Safety Information.....	3
Warnings	3
Specifications	4
Installation	5
Operating Instructions.....	5
Light/Dark Adjustments.....	6
User Mode.....	6
Manager Mode	6
Safety Features.....	7
Fault Messages.....	7
Error Codes	7
Recommended Settings.....	8
Daily Maintenance	9
Replacing the Release Sheet (Every 3-5 Weeks)	10
Replacing the Silicone Belt (Every 2-4 Months).....	10
Checking the Conveyor Belt Chain (Every 3-6 Months).....	11
Troubleshooting.....	12
Replacement Parts.....	15
Wiring Diagram	18
Notes.....	19
Limited Warranty	20

IMPORTANT

Antunes reserves the right to change specifications and product design without notice. Such revisions do not entitle the buyer to corresponding changes, improvements, additions or replacements for previously purchased equipment.

IMPORTANT

Keep these instructions for future reference. If the unit changes ownership, be sure this manual accompanies the equipment.

GENERAL

This manual provides the safety, installation, and operating procedures for the Horizontal Contact Toaster. We recommend that all information contained in this manual be read prior to installing and operating the unit.

This product is manufactured from the finest materials available and assembled to our strict quality standards. This unit has been tested at the factory to ensure dependable trouble-free operation.

WARRANTY INFORMATION

Please read the full text of the Limited Warranty in this manual.

If the unit arrives damaged, contact the carrier immediately and file a damage claim with them. Save all packing materials when filing a claim. Freight damage claims are the responsibility of the purchaser and are not covered under warranty.

The warranty does not extend to:

- Damages caused in shipment or damage as result of improper use.
- Installation of electrical service.
- Normal maintenance as outlined in this manual.
- Malfunction resulting from improper maintenance.
- Damage caused by abuse or careless handling.
- Damage from moisture into electrical components.
- Damage from tampering with, removal of, or changing any preset control or safety device.

SERVICE/TECHNICAL ASSISTANCE

If you experience any problems with the installation or operation of your unit, contact Antunes Technical Service at +1-877-392-7854 (toll free).

Fill in the information below and have it handy when calling Antunes Technical Service for assistance. The serial number is on the specification plate located on the rear of the unit.

Purchased From

Date of Purchase

Model Number

Serial Number

Manufacturing Number

Use only genuine Antunes replacement parts in this unit. Use of replacement parts other than those supplied by the manufacturer will void the warranty.

IMPORTANT SAFETY INFORMATION

Use the following guidelines for safe operation of the unit.

- Read all instructions before using equipment.
- For your safety, the equipment is furnished with a properly grounded cord connector. Do not attempt to defeat the grounded connector.
- Install or locate the equipment only for its intended use as described in this manual. Do not use corrosive chemicals in this equipment.
- Do not operate this equipment if it has a damaged cord or plug, if it is not working properly, or if it has been damaged or dropped.
- This equipment should be serviced by qualified personnel only. Contact Antunes Technical Service for adjustment or repair.
- Do not block or cover any openings on the unit.
- Do not immerse cord or plug in water.
- Keep cord away from heated surfaces.
- Do not allow cord to hang over edge of table or counter.
- Turn the power off, unplug the power cord, and allow unit to cool down before performing any service or maintenance on the unit.
- The toaster should be grounded according to local electrical codes to prevent the possibility of electrical shock. It requires a grounded receptacle with separate electrical lines, protected by fuses or circuit breaker of the proper rating.
- All electrical connections must be in accordance with local electrical codes and any other applicable codes.
- Do not clean this appliance with a water jet.
- Bread may burn. Therefore toasters must not be used near or below curtains or other combustible walls and materials. Failure to maintain safe operating distances may cause discoloration or combustion.
- Make sure both ends of the Silicone Belt are aligned evenly before installing the Silicone Belt Pin.
- Failure to use the Release Sheet may result in damage to the equipment and loss of warranty coverage.

WARNINGS

Be advised of the following warnings when operating and performing maintenance on this unit.

- If the supply cord is damaged, it must be replaced by the manufacturer or its service agent or a similarly qualified person in order to avoid a hazard.
- Do not modify the power supply cord plug. If it does not fit the outlet, have a proper outlet installed by a qualified electrician.
- Do not use an extension cord with this appliance.
- Electrical ground is required on this appliance.
- Check with a qualified electrician if you are unsure if the unit is properly grounded.
- If a chemical cleaner is used, be sure it is safe to use on cast aluminum. Observe all precautions and warnings on product label.
- Inspection, testing, and repair of electrical equipment should only be performed by qualified service personnel.
- Do not use a sanitizing solution or abrasive materials. The use of these may cause damage to the stainless steel finish.
- Chlorides or phosphates in cleaning agents (e.g. bleach, sanitizers, degreasers or detergents) could cause permanent damage to stainless steel equipment. The damage is usually in the form of discoloration, dulling of metal surface finish, pits, voids, holes, or cracks. This damage is permanent and not covered by warranty.

The following tips are recommended for maintenance of your stainless steel equipment:

- Always use soft, damp cloth for cleaning, rinse with clear water and wipe dry. When required, always rub in direction of metal polish lines.
- Routine cleaning should be done daily with soap, ammonia detergent, and water.
- Stains and spots should be removed with a vinegar solution.
- Finger marks and smears should be removed with soap and water.
- Hard water spots should be removed with a vinegar solution.

SPECIFICATIONS

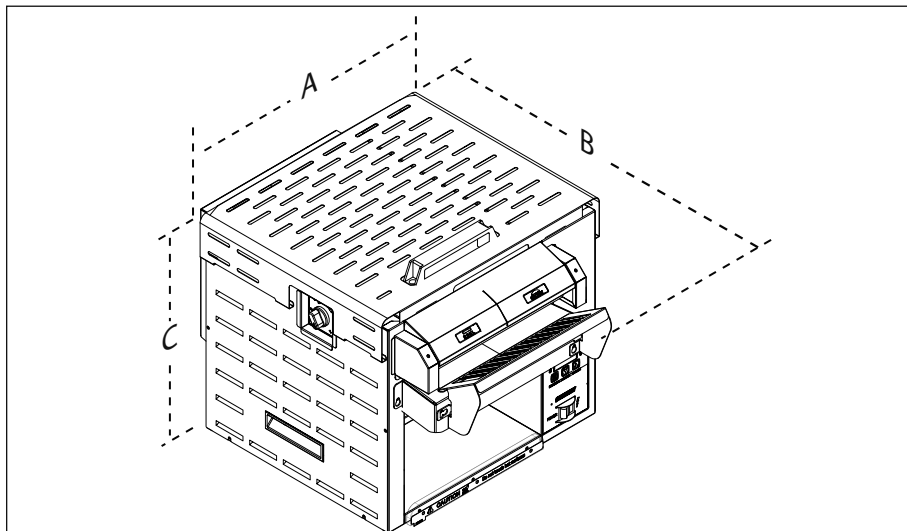

Model & Mfg. No.	Width (A)	Depth (B)	Height (C)
HCT-2000 9210322	20 25/32" (523 mm)	26 30/32" (684 mm)	18 13/32" (467 mm)

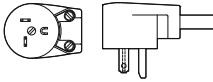
Model	Volts	Watts	Amps	Hertz	Plug Description	Configuration
HCT-2000 9210322	208	2400	12	50/60	6-20P 20 Amp., 250 Volt Right Angle	

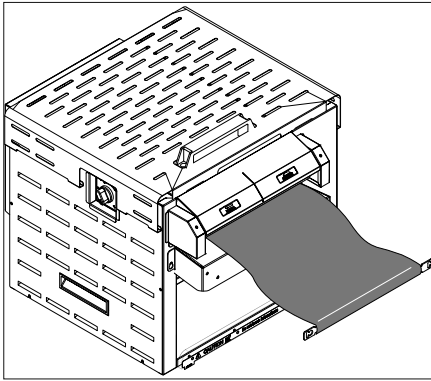

Figure 1. Installing Release Sheet

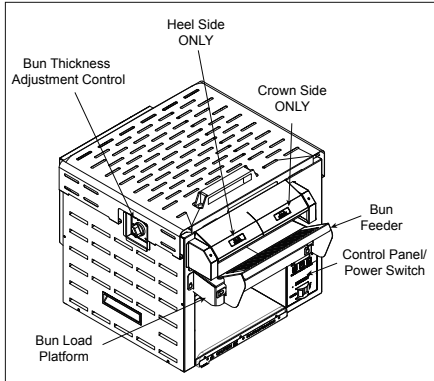

Figure 2. HCT-2000 Toaster

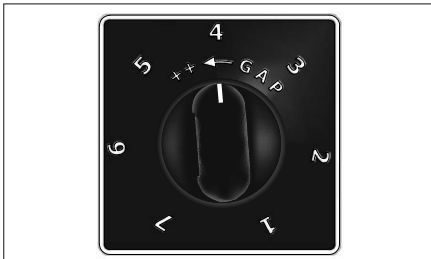

Figure 3. Bun Compression Setting

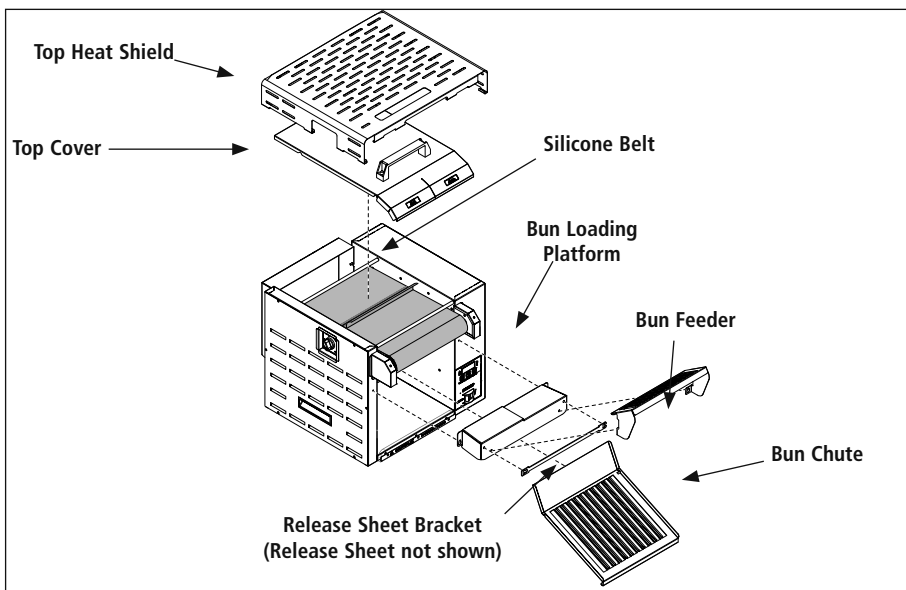

Figure 4. Components

INSTALLATION

1. Remove unit and all packing materials from shipping carton.
2. The unit should come with the items listed below:
 - Bun Chute and Bun Feeder
 - Bun Load Platform and Release Sheet Retainer
 - Three Release Sheets

NOTE: If any parts are missing or damaged, contact Antunes Customer Service IMMEDIATELY at +1-877-392-7856 (toll free).

3. Remove all packing materials and protective coverings from the unit.
4. Wipe all surfaces of the unit with a hot damp cloth.

NOTE: Do NOT use a dripping wet cloth. Wring out before use.

When placing the toaster into service, pay attention to the following guidelines.

- Make sure the power switch is off and the unit is at room temperature before plugging in the power cord.
- Do not block or cover any openings on the unit.
- Do not immerse the power cord or plug in water.
- Keep the power cord away from heated surfaces.
- Do not allow the power cord to hang over edge of table or counter.
- Provide 1" clearance on the sides and rear of the unit to prevent any damage to nearby walls and materials.

1. Place the unit on a flat, sturdy location.
2. Install the Bun Chute.
3. Install the Release Sheet onto the Release Sheet Bracket and hang the Release Sheet Bracket onto the Bun Load Platform. Turn the unit on and allow the Conveyor Belt to draw the sheet into the unit. Turn the unit off.
4. Attach the Bun Load Platform to the front of the unit.
5. Attach the Bun Feeder.

IMPORTANT: Do not plug any other power cords into the receptacles on the toaster.

6. Install the Top Cover and Heat Shield.
7. Plug in the power cord.



Bread may burn. Therefore toasters must not be used near or below curtains or other combustible walls and materials. Failure to maintain safe operating distances may cause discoloration or combustion.

OPERATING INSTRUCTIONS

NOTE: The unit includes a Bun Compression Setting that is factory set. The recommended Bun Thickness setting is #4 (Figure 3).

1. Turn on the power and allow the unit to warm up for 30 minutes.

The temperature display flashes "LO" until the toaster reaches its preset operating temperature. When the toaster approaches the preset temperature of 570°F (293°C), "USE" appears in the temperature display and the unit is ready to toast buns. If "USE" does not appear in the window after approximately 30 minutes, contact your Authorized Service Agency.

2. Insert Crowns and Heels cut side DOWN across the Bun Load Platform and into the toaster (Figure 2).

NOTE: Observe the CROWN and HEEL labels on the front of the unit for proper toasting. Insert buns cut side DOWN.

3. Toasted buns will drop out of the unit and down the Bun Chute after approximately 14 seconds.
4. Test at least four buns before putting the toaster into service.
5. Turn the unit off when finished toasting for the day and proceed with the Daily Cleaning as outlined in the Maintenance section of this manual.

LIGHT/DARK ADJUSTMENTS

The light/dark value can be adjusted when the unit is displaying "LO" or "USE". To adjust the light/dark value, press the **LIGHTER** or **DARKER** button. The display will change to show the current light/dark value.

NOTE: The default light/dark value is d0.

Press the **LIGHTER** or **DARKER** button to change the light/dark value. The adjustment range is L1-L9 and d0-d9. L9 is the lightest, d0 is the middle, and d9 is the darkest setting.

To save the light/dark value, press the **PROGRAM** button or wait 5 seconds until the screen displays "LO" or "USE".

NOTE: Adjusting the light/dark value does NOT change the temperature. It changes the speed of the conveyors. The light/dark value will reset to the d0 value when the unit is turned off.

USER MODE

User Mode allows an operator to view the toaster settings but does not permit any adjustments.

1. Press and hold the **PROGRAM** button for 5 seconds. After 5 seconds, the display will show the actual temperature of the Platen Heater.
2. Press the **LIGHTER** button to view the setpoint of the Platen Heater.
3. Press the **PROGRAM** button to proceed to the Auxiliary Heater menu. The display will show the actual temperature of the Auxiliary Heater.
4. Press the **LIGHTER** button to view the setpoint of the Auxiliary Heater.
5. Press the **PROGRAM** button to proceed to the Motor Menu. The display will show the actual speed of the motor.
6. Press the **LIGHTER** button to view the setpoint of the motor.

NOTE: The unit will exit User Mode after 5 seconds of keypad inactivity.

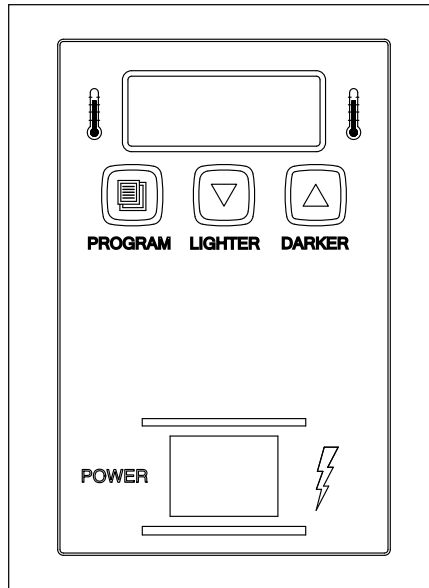

Figure 5. Toaster Control Panel

MANAGER MODE

Manager Mode allows an operator to view and adjust the following settings:

- Platen Heater Temperature
- Auxiliary Heater Temperature
- Motor Speed
- Temperature Units

Manager Mode also allows an operator to view (but not adjust) the Ambient Temperature of the Control Compartment..

1. Turn the unit off.
2. Turn the power on while holding the **PROGRAM** button. Continue to hold the button until "ENA" appears on the display (after approximately 10 seconds).
3. Release the **PROGRAM** button. The display now shows the Platen Setpoint Temperature.
4. To adjust the Platen Setpoint, press the **LIGHTER** or **DARKER** buttons to reach the desired temperature.

NOTE: The recommended temperature setting for the Platen Heater is 570°F (299°C).

5. Press the **PROGRAM** button to proceed to the Auxiliary Heater Setpoint Temperature.
6. To adjust the Auxiliary Heater Setpoint, press the **LIGHTER** or **DARKER** buttons to reach the desired temperature.

NOTE: The recommended temperature setting for the Auxiliary Heaters is 400°F (204 °C).

7. Press the **PROGRAM** button to proceed to the Motor Speed Setpoint.
8. Adjust the Motor Speed Setpoint by pressing the **LIGHTER** or **DARKER** buttons to reach the desired speed. the recommended setting is d0.

NOTE: The Motor Speed is adjustable from 1-100. The recommended setting is 67.

9. Press the **PROGRAM** button to proceed to Temperature Units.
10. To change the Temperature Units from Fahrenheit or Celsius, press the **LIGHTER** or **DARKER** button.
11. Press the **PROGRAM** button to proceed to the Ambient Temperature of the Control Compartment.

NOTE: No changes can be made to the Ambient Temperature of the Control Compartment. Temperatures under 150°F (66°C) are acceptable.

12. Press and hold the **PROGRAM** button to save any changes.

NOTE: The unit will exit Manager Mode after 30 seconds of keypad inactivity.

SAFETY FEATURES

A Hi-Limit Control turns off electric power to the heaters and control circuits if the unit overheats. To reset the control, allow 10-15 minutes for the unit to cool, then locate the Hi-Limit Control on the rear of the unit. Remove the black protective cap, press the button, and reinstall the protective cap.

NOTE: If the Hi-Limit Control requires continuous resetting, contact your Authorized Service Agency.

FAULT MESSAGES

The Control Display will flash fault messages when there is a problem with the unit.

"HI" will flash if the Platen Heater temperature is 30°F more than the setpoint or if the Platen Thermocouple is disconnected or open.

"HI" and **"USE"** will flash if the Auxiliary Heater temperature is 50°F more than the setpoint or if the Auxiliary Thermocouple is disconnected or open.

"CHEC" will flash when the control compartment ambient temperature is more than 150°C (66°C). All heaters will shut off. The unit will not restart until the control compartment ambient temperature falls below 140°F (60°C).

"PO" will flash if the incoming power drops below 190 volts. The toaster will shut down.

"StoP" will flash when the motor has stopped for seven continuous seconds.

"SpEd" will flash when the motor speed has dropped 25% below the setpoint for 30 continuous seconds.

ERROR CODES

If any of the following Error Codes appear, turn the power off, allow the unit to cool, and turn the power back on. If the error repeats, contact your Authorized Service Agency for assistance.

ERR 1: Internal error. Cycle the Power Switch. If error persists, replace the board.

ERR 2: Internal error. Cycle the Power Switch. If error persists, replace the board.

ERR 3: Internal error. Cycle the Power Switch. If error persists, replace the board.

ERR 4: Invalid DIP Switch setting. The only approved setting is (left to right) up-up-up-down (1 on; 2, 3, 4 off).

ERR 5: Internal error. Cycle the Power Switch. If error persists, replace the board.

ERR 6: Internal error. Cycle the Power Switch. If error persists, replace the board.

ERR 7: Not used.

ERR 8: Shorted Platen Thermocouple.

ERR 9: Open Platen Thermocouple.



Horizontal Contact Toaster | HCT-2000



HCT-2000

The Horizontal Contact Toaster is the most recent development from Antunes, the recognized leader in bun toasting within the foodservice industry. This new toaster, designed specifically for Arby's restaurants, features a space-saving horizontal design with two lanes for toasting heels and crowns.

With a front load and front return, the Horizontal Contact Toaster can be easily integrated into any prep line. The included bun chute delivers toasted product to a heated base, which keeps product hot and fresh until needed for sandwich assembly.

The Horizontal Contact Toaster also allows operators to make quick adjustments to toast quality with just the press of a button, making it easy to toast a variety of different bread products.

To ensure your toaster operates properly in your restaurant, please use the settings listed below.

DEFAULT SETTINGS

Compression - #4

Speed Setting - d0 (14 seconds)

Platen Heater - 570°F (299°C)

Auxiliary Heater - 400°F (204°C)

Motor Speed - 67

⚠ WARNING ⚠

Turn the power off, unplug the power cord, and all the unit to cool down for 30 minutes before performing any service or maintenance.

⚠ WARNING ⚠

To prevent damage to the unit, do not use abrasive cleaners on the Release Sheet or Silicone Belts.

⚠ WARNING ⚠

Failure to use Release Sheets may result in damage to the unit and loss of warranty coverage.

DAILY MAINTENANCE

AT CLOSE

- Turn the unit OFF and unplug at the outlet. Allow unit to cool.
- Remove the Release Sheet Retainer and Release Sheet. Fill a full-sized pan with hot Detergent Solution and place Release Sheet into pan to soak.
- Take The Release Sheet Retainer and Bun Load Platform to the dishwashing sink. Hand wash, rinse; then sanitize for a minimum of 60 seconds. Allow to air dry. Return to service line; set aside for reassembly at open.

AT OPEN

- Make sure unit is off and unplugged at the outlet.
- Remove the Release Sheets.
- Fill a full-size pan with hot Detergent Solution and place Release Sheet into pan to soak.
- Remove the Heat Shield and Top Cover and on-line clean the Silicone Belts. Do NOT submerge.
- Remove the Bun Chute and take to dishwashing sink.

NOTE: Do NOT place parts into the powerwash sink.

- Pre-rinse, hand wash, rinse and sanitize parts. Return parts to service line.

- Fill a clean 1/6-size, 6-inch deep s/s pan with hot Detergent Solution; a second pan with clean rinse water; and a third pan with Sanitizer Solution. Place a clean, white towel in each pan and place near toaster.
- Wipe the Bun Load Platform.
- Wipe both sides of the Silicone Belts (side facing out first) with a clean, white towel and hot Detergent Solution. Rinse with a clean, white towel and clean rinse water. Sanitize using a clean, white towel and Sanitizer Solution.
- Rotate Belt around so the side facing inward is facing out, exposing the soiled areas of the Silicone Belt. Wash, rinse, and sanitize following the above step.
- Remove Release Sheet that has been soaking and take to dishwashing sink. Hand wash, rinse, and sanitize both sides. Return to service line.
- Wipe outside of toaster with a clean, white towel and **hot** Detergent Solution.
- Reinstall the Bun Chute, Top Cover, Heat Shield, and Bun Load Platform. Install the Release Sheet.

NOTE: Rotate sheet daily from brown to gold side.

- Install the Heat Shield. Plug unit in.
- Turn toaster ON 30 minutes prior to opening.

NOTE: Check the Release Sheet to make sure it is not caught in the Conveyor. Additional Release Sheets can be purchased under P/N 7001256 (3-Pack).

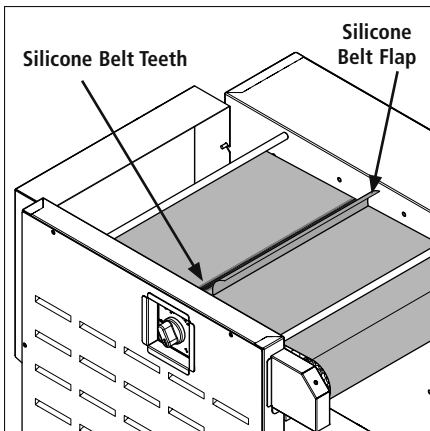

Figure 6. Removing Silicone Belt

REPLACING THE RELEASE SHEET (EVERY 3-5 WEEKS)

NOTE: Depending on toaster usage and on how well it is cleaned daily, the Release Sheet should last between 21–35 days.

1. Turn the power off, unplug the power cord, and allow the unit to cool.
2. Remove the Release Sheet Bracket. Discard the old Release Sheet. Keep the Bracket.
3. Slide the Release Sheet Bracket through the end of the new Release Sheet (Figure 1).
4. Hang the Release Sheet Bracket onto the Bun Load Platform. Insert the loose end of the Release Sheet into the toaster (Figure 1). Turn the unit on and allow the Conveyor Belt to draw the Release Sheet into the unit. Turn the unit off.

REPLACING THE SILICONE BELT (EVERY 2–4 MONTHS)

NOTE: The Silicone Belt should last 2–4 months. Additional Silicone Belts may be purchased from your Authorized Service Agency.

1. Turn the unit off, unplug the power cord, and allow the unit to cool. Set the Bun Thickness Adjustment Control to 7.
2. Put on Heat Resistant gloves and remove the Top Cover and Heat Shield.
3. Face the front of the toaster. Push the front of the conveyor IN and DOWN so it locks into place. This releases the belt tension and allow it to be free.

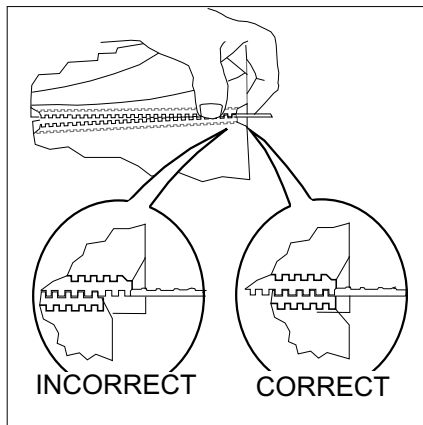

Figure 7. Aligning Belt Teeth

4. Make sure flap of the Silicone Belt is accessible on the top side. Pull the Silicone Belt Pin out of the zipper on the Silicone Belt (Figure 6).
5. Disconnect the two clips on the inside of the Belt Wrap from the conveyor Belt Chain.
6. Remove and discard the old Silicone Belt. The Silicone Belt connects to the Conveyor Belt Chain using clips attached to the belt. Disconnect these clips when removing the Silicone Belt.
7. Wipe the Conveyor Belt Chain with a clean towel dampened sanitizer and allow to air dry.
8. Install the new Silicone Belt in the front of the toaster above the Platen. Wrap the Silicone Belt around the Conveyor Belt Chain with the zipper flap exposed to the REAR of the unit (Figures 6 and 7).
9. Be sure to connect the clips on the Silicone Belt to the Conveyor Belt Chain before proceeding.

NOTE: Align the edges of the Silicone Belt properly (Figure 7) or the Silicone Belt may be damaged.

10. Connect the Silicone Belt with the Belt Pins.
11. Set the Bun Thickness Adjustment Control to the correct operating setting.
12. Reassemble the unit and test before returning to service.

⚠ WARNING ⚠

Align the ends of the Silicone Belt properly (Figure 7) or the belt may be damaged.

⚠ WARNING ⚠

The unit can retain heat. Be sure to wear Heat-Resistant Gloves to avoid personal injury.

CHECKING THE CONVEYOR BELT CHAIN (EVERY 3–6 MONTHS)

MEASURING CONVEYOR BELT CHAIN

1. Turn the unit off, unplug the power cord, and allow the unit to cool. Set the Bun Thickness Adjustment Control to 7.
2. Put on Heat Resistant gloves and remove the Top Cover and Heat Shield.
3. Make sure flap of the Silicone Belt is accessible on the top side. Pull the Silicone Belt Pins out of the zipper on the Silicone Belts (Figure 6).
4. Remove the Bun Load Platform (Figure 2).
5. Face the front of the toaster. Push the front of the conveyor IN and DOWN so it locks into place. This releases the belt tension and allow it to be free.
6. Remove the Silicone Belt.
7. Locate the center of the Conveyor Belt Chain. Pull up on the chain to test the slack.
8. If the chain can be pulled more than 1.5" (3.8 cm) above the top of the Center Support Cover (Figure 8), remove links as described in the section titled Adjusting Conveyor Belt Chain.
9. If the chain is okay, reassemble the unit and set the Bun Thickness Adjustment Control to the normal operating setting.

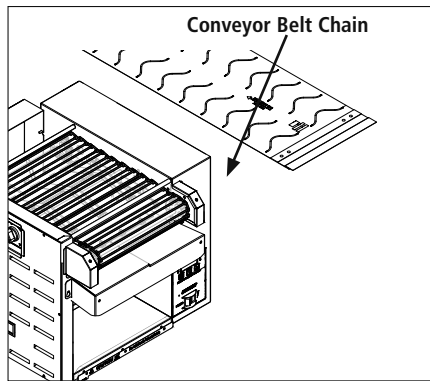

Figure 8. Conveyor Chain

ADJUSTING CONVEYOR BELT CHAIN

1. Turn the unit off, unplug the power cord, and allow the unit to cool. Set the Bun Thickness Adjustment Control to 7.
2. Put on Heat Resistant gloves and remove the Top Cover and Heat Shield.
3. Make sure flap of the Silicone Belt is accessible on the top side. Pull the Silicone Belt Pin out of the zipper on the Silicone Belt (Figure 6).
4. Remove the Bun Load Platform (Figure 2).
5. Face the front of the toaster. Push the front of the conveyor IN and DOWN so it locks into place. This releases the belt tension and allow it to be free.
6. Remove the Silicone Belt.
7. Remove one complete link from Conveyor Belt Chain by squeezing two links together to disconnect the chain on both sides. Remove one link and then reconnect the Conveyor Belt Chain.
8. Reinstall the Silicone Belt. Secure with the Belt Pin.
9. Reassemble the unit and set the Bun Thickness Adjustment Control to the normal operating setting.

REPLACING CONVEYOR BELT CHAIN

1. Turn the unit off, unplug the power cord, and allow the unit to cool. Set the Bun Thickness Adjustment Control to 7.
2. Put on Heat Resistant gloves and remove the Top Cover and Heat Shield.
3. Make sure flap of the Silicone Belt is accessible on the top side. Pull the Silicone Belt Pin out of the zipper on the Silicone Belt (Figure 6).
4. Remove the Bun Load Platform (Figure 2).
5. Face the front of the toaster. Push the front of the conveyor IN and DOWN so it locks into place. This releases the belt tension and allow it to be free.
6. Remove the Silicone Belt.
7. Squeeze two links together to disconnect the Conveyor Belt Chain on both sides.
8. Remove the Conveyor Belt Chain from the unit.
9. Install and connect the new Conveyor Belt Chain.
10. Reinstall the Silicone Belt. Secure with the Belt Pin.
11. Reassemble the unit and set the Bun Thickness Adjustment Control to the normal operating settings.

TROUBLESHOOTING

Problem	Possible Cause	Corrective Action
Control Display flashes "LO" continuously. Buns not toasting properly.	Platen temperature is below 440°F (226°C).	Allow the unit to warm up for 30 minutes and then recheck. If the Control Display still reads "LO", contact your maintenance person or Authorized Service Agency for service.
Control Display flashes "LO" continuously. Buns burn.	Failed Platen Thermocouple.	Contact your maintenance person or Authorized Service Agency for service.
	Failed Control Board.	
Control Display flashes "PO" continuously.	The power to the unit is below 190 volts.	Turn the power off and then on. If the display still shows "PO", check the power cord, plug, and outlet for damage. Reset the Circuit Breakers. Contact your maintenance person, Authorized Service Agency, or electrician for service.
	Failed Control Board.	
	Failed Transformer.	
Control Display flashes "CHEC" continuously.	Control Compartment ambient temperature is above 140°F (60°C).	Verify side vents on toaster are unblocked and not near other heating appliances. If problem still persists, contact your maintenance person or Authorized Service Agency for service.
	Failed Cooling Fan.	
	Failed Control Board.	
Control Display flashes "HI" continuously. Buns burn.	Failed Platen Solid State Relay.	Contact your maintenance person or Authorized Service Agency for service.
	Failed Control Board.	
	Failed Platen Thermocouple.	
Control Display flashes "ERR 9" continuously. Buns not toasting properly.	Loose Platen Thermocouple connection on Control Board or the Platen Thermocouple is open.	Re-secure the Platen Thermocouple connection to the Control Board. If the Control Display still reads "ERR 9", check the Thermocouple for continuity. Contact your maintenance person or Authorized Service Agency for service.
	Failed Control Board.	
Control Display flashes "HI" and "USE" after 20–30 minutes.	Loose Auxiliary Thermocouple connection on Control Board or Auxiliary Thermocouple is open.	Re-secure the Auxiliary Thermocouple connection to the Control Board. If the Control Display still reads "HI" and "USE", check Thermocouple for continuity. Contact your maintenance person or Authorized Service Agency for service.
	Faulty Auxiliary Solid State Relay.	
Control Display flashes "StoP".	Mechanical bind in one or both conveyors.	Enter User Mode to check the motor speed. Check both conveyors for mechanical binds. Test the motor. Replace necessary parts. Contact your maintenance person or Authorized Service Agency for service.
	Damaged ball bearings.	
	Conveyor Belt Chain loose or damaged.	
	Drive chain or sprockets damaged.	
	Motor has shortened tachometer.	
	Motor is not receiving voltage.	
Control Display flashes "SpEd".	Mechanical bind in one or both conveyors.	Enter User Mode to check motor speed. Check both conveyors for mechanical binds. Replace necessary parts. Contact your maintenance person or Authorized Service Agency for service.
	Damaged ball bearings.	
	Conveyor Belt Chain loose or damaged.	
	Drive chain or sprockets damaged.	

TROUBLESHOOTING (continued)

Problem	Possible Cause	Corrective Action
No Control Display.	Power cord not plugged in.	Plug power cord into the proper electrical outlet.
	Hi-Limit Control has tripped.	Allow unit to cool and reset the Hi-Limit Control. If it trips again, contact your maintenance person or Authorized Service Agency.
	Circuit Breakers turned off or tripped. Damaged electrical outlet, plug, or cord. Power Switch damaged.	Reset Circuit Breakers. If they trip again, check the power cord, plug, and outlet for damage. Contact your maintenance person, Authorized Service Agency, or electrician for service.
	Faulty Transformer.	Replace Transformer.
Conveyor does not turn.	Damaged or Missing Roller Tensioner.	Adjust or replace Roller Tensioner.
	Conveyor Belt/Chain has stretched. Chain skipping on sprockets.	Measure and adjust the Conveyor Belt Chain as described in the Maintenance section of this manual.
	Motor Drive Chain came off Sprocket(s).	Reinstall Drive Chain.
	Drive Chain needs lubrication.	Lubricate chain with Lubit-8 (P/N 2190152).
	Drive Motor has failed.	Contact your maintenance person or Authorized Service Agency for service.
Buns not toasting adequately.	Compression Settings are incorrect.	Use the recommended settings.
	Temperature Setting is incorrect.	Verify that the Platen (SP-P) is set to 570°F (297°C) and the Auxiliary (SP-A) is set to 400°F (204°C). For making changes to the setpoint temperature, see the Installation section of this manual.
	Release Sheet is worn or needs cleaning (replace every 3–5 weeks).	Inspect Release Sheet for cleanliness, worn spots, tears, or wrinkles. Clean or replace Release Sheet as described in the Maintenance section of this manual.
	Silicone Belt is worn or need cleaning (replace every 2–4 months).	Replace or clean Silicone Belt as described in the Maintenance section of this manual.
	Silicone Belt are not tacky/sticky.	Replace or clean Silicone Belt as described in the Maintenance section of this manual.
	Buns do not meet specifications.	Contact your bun supplier.

TROUBLESHOOTING (continued)

Problem	Possible Cause	Corrective Action
Crowns and/or Heels must be forced into the toaster. Buns sticking and burning.	Silicone Belt not being cleaned properly.	Clean Silicone Belts as described in the Maintenance section of this manual.
	Silicone Belt are not tacky/sticky (replace every 2–4 months).	Clean Silicone Belts. If the Silicone Belts are too worn, replace them as described in the Maintenance section of this manual.
	Silicone Belt are dirty, worn, or damaged (replace every 2–4 months).	Clean or replace Silicone Belts as described in the Maintenance section of this manual.
	Release Sheet is not being cleaned properly.	Clean both sides of the black and silver Release Sheet as described in the Maintenance section of this manual.
	Release Sheet is not being reversed as required.	Reverse the Release Sheet or replace Release Sheet as described in the Maintenance section of this manual.
	Release Sheet is dirty, worn, or damaged (replace every 3–5 weeks).	Clean or replace the Release Sheet as described in the Maintenance section of this manual.
	Conveyor Belt Chain is skipping on Sprockets.	Measure and adjust the Conveyor Belt Chain as described in the Maintenance section of this manual.
	Silicone Belts slipping over Conveyor Belt Chain.	Remove Silicone Belts and clean the Conveyor Belt Chain links and Silicone Belts as described in the Maintenance section of this manual.
	Drive Motor stalls intermittently.	Contact your maintenance person or an Authorized Service Agency for service.
	Compression Settings are incorrect.	Use the recommended settings.
Buns are not inserted into the toaster properly.	Buns must be inserted with the cut sides facing down on the correct Heel or Crown side.	
New Silicone Belts do not fit.	Compression Settings are incorrect.	Set Bun Thickness Compression Knobs to 1 when replacing Silicone Belts or when adjusting the Conveyor Belt Chain.
	Silicone Belts not installed correctly.	Install Silicone Belts between the Support Rods with the zipper flap exposed and facing up.
	Silicone Belts are damaged or are the wrong type for your unit.	Replace with 7001256.
Toaster makes unusual sounds.	Compression Settings are too tight.	Set Bun Thickness Compression Knobs to the correct (or larger) setting.
	Silicone Belts are installed incorrectly.	Silicone Belts must be installed as described in the Maintenance section of this manual.
	Silicone Belt Pin rubbing on housing.	Center the Pin in the Silicone Belt zipper.
	Conveyor Belt Chain has stretched.	Measure and adjust the Conveyor Belt Chain as described in the Maintenance section of this manual.
	Conveyor Belt Chain adjusted incorrectly.	
	Sugar and/or carbon has accumulated inside the Silicone Belt and between the Conveyor Belt Chain and Tensioner Slide Rails.	Remove Silicone Belts, clean Conveyor Belt Chain links just as you clean the Silicone Belts daily, and then clean the Slide Rails on the Tensioners. Next, clean the Silicone Belt on both sides before reinstalling it.
	Motor Drive Chain needs lubrication.	Lubricate the Drive Chain carefully with Lubit-8 (P/N 2140152) at least once a year.
A Conveyor Shaft bearing is binding.	Contact your maintenance person or Authorized Service Agency for service.	

REPLACEMENT PARTS

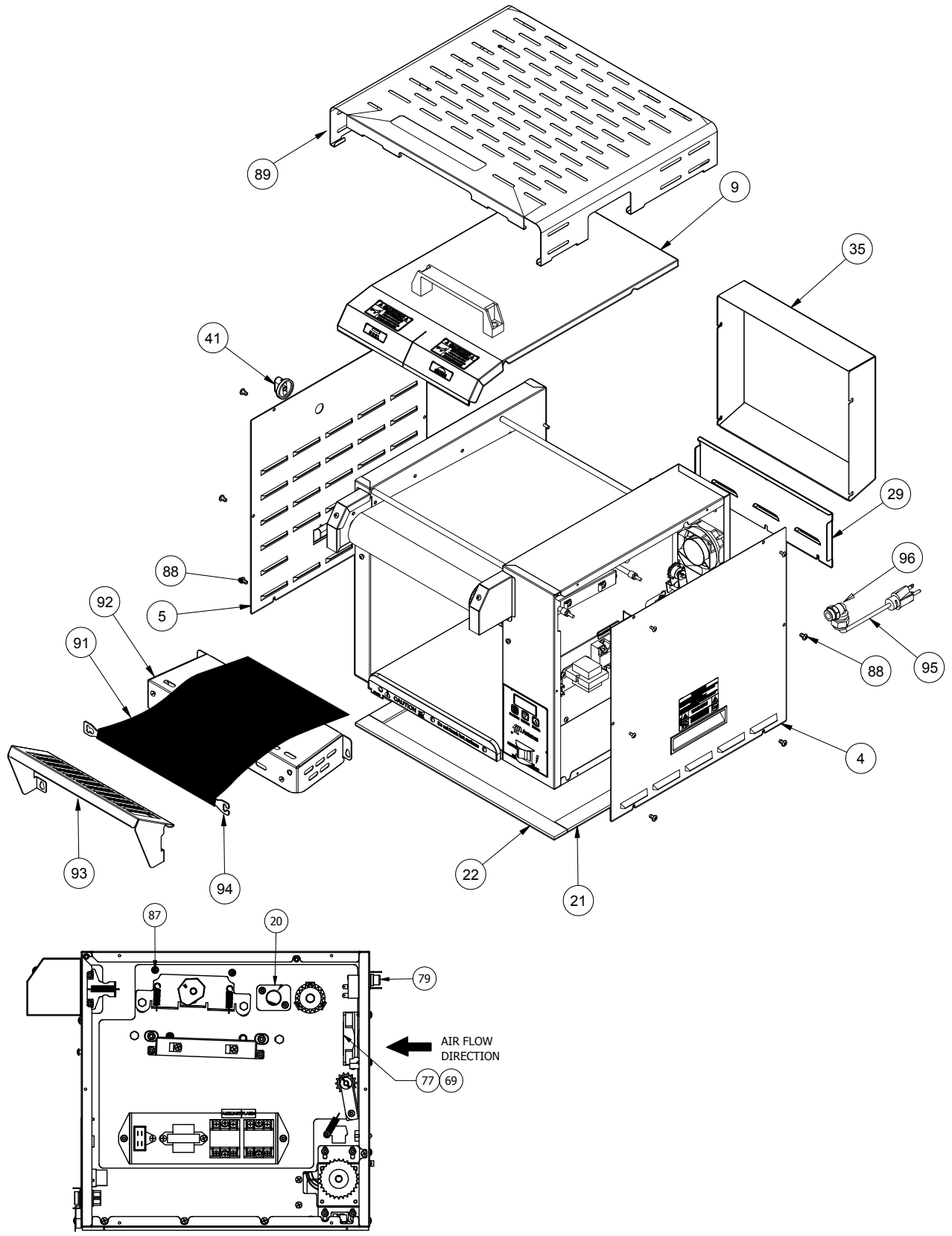

REPLACEMENT PARTS (continued)

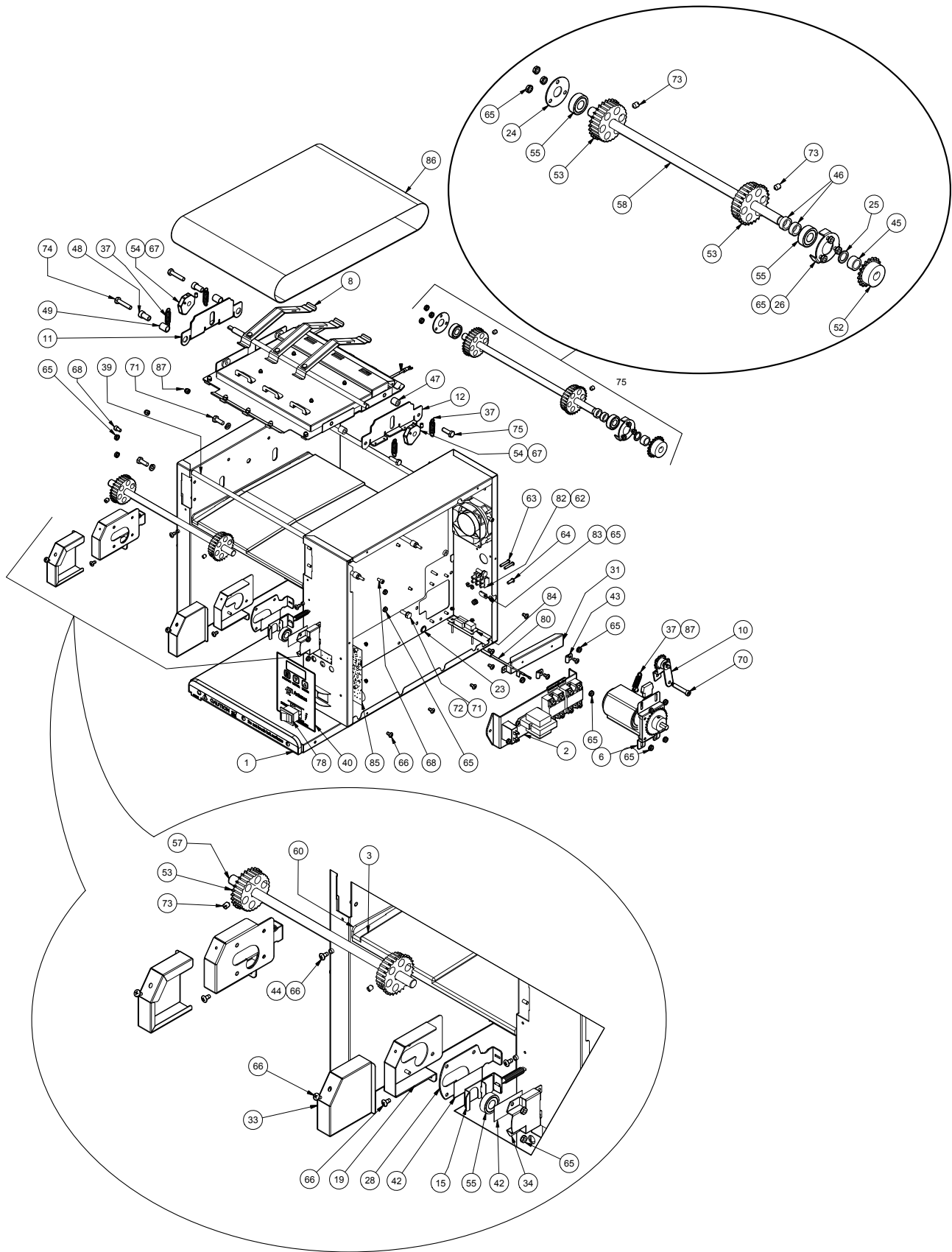

REPLACEMENT PARTS (continued)

Item	Part No.	Description	Qty.	Item	Part No.	Description	Qty.
1	0012619	Base Assembly	1	53	2150190	Sprocket, 25B28 1/2Bore Stepped Tooth	4
2	0012629	Elec. Panel Assembly	1	54	2150317	Cam	2
3	0013460	Platen Assembly	1	55	2150384	Bearing Assy, High Temp 1 1/8" Od X 1/2" Id	4
4	0013461	Ctrl Housing Cover, Assy	1	56	2150421	Cam Shaft	1
5	0013462	End Housing Cover Assy	1	57	2150430	Shaft, Idler	1
6	0013463	Drive Motor Assembly	1	58	2150431	Shaft, Drive	1
7	0013464	Bun Compression Plate Assy	1	59	2150432	Chain, Drive	1
8	0013465	Tensioner Assembly, Wire Belt	3	60	2180303	Spacer, Teflon	2
9	0013466	Top Cover Assy	1	61*	3040105	Nut, Hex 'Keps' # 4-40	1
10	0013467	Assy, Drive Chain Tensioner	1	62*	3060101	Nut, Hex #06-32 St.stl	1
11	0013485	Cam Brkt & Thrust Strip Assy, Lh	1	63*	3060123	Screw, Mach #6-32 X 7/8" Slrndhd	1
12	0013486	Cam Brkt & Thrust Strip Assy, Rh	1	64*	3080124	Screw, Mach. One Way #8-32	1
13	0013492	Conveyor Belt Assy 47/2	1	65*	3080143	Nut, Hex 'Keps' #8-32	1
14	0021724	Weldment, Bearing Brkt & Spring Guide - Rh	1	66*	3080203	Screw, 8-32 X 3/8" W/Int. Tooth Washer	1
15	0021725	Weldment, Bearing Brkt & Spring Guide - Lh	1	67*	3100187	Screw Set, #10-32 X 3/8 Hex Socket-Cone Point	1
16	0022237	Weldment, Control Housing	1	68*	3100199	Scr, #10-32 X 3/8 Lg Socket Hd Cap	1
17	0022238	Weldment, End Housing	1	69*	3100213	Scr, Phphanhd #10-16 X 3/4" Thrd Form	1
18	0022239	Weldment, Idler Support Bracket, Lh	1	70*	3100234	Hex Socket Shoulder Screw, #10-32 X 1 1/2"	1
19	0022240	Weldment, Idler Support Bracket, Rh	1	71*	3250103	Screw, Hexcap 1/4 X 3/4"	1
20	0022763	Weldment, Aux. Heater Wire Bracket	1	72*	3250154	1/4 Lock Washer	1
21	0200301	Gasket, Base 14.26" Lg	2	73*	3250163	Set Screw, 1/4-28 X 5/16"	1
22	0200302	Gasket, Base 19.13" Lg	2	74*	3250193	Screw, Hex Head, 1/4-20 X 1.375" Screw	1
23	0400280	Bushing, Snap	1	75*	3250195	Screw, Hex Cap 1/4-20 X 7/8"	1
24	0500464	Bearing Retainer	1	76*	3250212	Set Screw, Knurl Grip Cup Point, 1/4-28 Unf-2A 3/8"	1
25	0504321	Spacer 0.503 X 0.69 X 0.06"	1	77	4000202	Fan, Axial - 230V, Metal Housing & Imp	1
26	0506067	Retainer, Bearing	1	78	4010245	Rocker Switch, Sealed Dpst	1
27	0506241	Plate, Tensioner Lh	1	79	4030332	Thermostat, Hi-Limit	1
28	0506242	Plate, Tensioner Rh	1	80	4050214	Thermocouple, Type K (Open End)	1
29	0506254	Back Door	1	81	4060107	Cable Tie, 1/8"W X 5"	20
30	0506255	Cover, Motor	1	82	4060355	Terminal Block 3 Pole	1
31	0506284	Thermocouple Bracket	1	83	4060374	Grounding Lug	1
32	0507369	Cover, Idler Support Bracket, Lh	1	84	4070154	Varistor Board	1
33	0507370	Cover, Idler Support Bracket, Rh	1	85	4070247	Assy-Pcb, Ctrl W/Motor (Arby's)	1
34	0507371	Bracket, Tensioner	2	86	7001095	Black Wavy Silicone Belt	1
35	0507379	Cover, Rear	1	87*	308P340	8-32 Acorn Nut S.s.	1
36	0600141	Spring, Compression	2	88*	308P157	Screw, Tap 8-32 X 3/8" Lg	1
37	0600156	Spring, Cam Adjustment	5	89	0506248	Heat Shield	1
38	0700979	Wire Set Arbys	1	90	0800485	Wire Bun Chute (not shown)	1
39	0800426	Support Rod	2	91	7001256	Release Sheet (pk of 3)	1
40	1002669	Label, Control	1	92	0022243	Bun Landing Platform	1
41	2100253	Knob, 1/4" Shaft, Push-On	1	93	0507417	Bun Feeder	1
42	2100334	Thrust Strip, Teflon	4	94	0506221	Release Sheet Bracket	1
43	2110197	Clip, Steel Cable	2	95	0700737	Power Cord 20A, 250V, Rt Angle	1
44	2120148	Spacer, Brass	2	96	0400354	90 Degree Strain Relief	1
45	2120164	Spacer 0.503 X 0.69 X 0.359	1	97	0400379	Locknut (power cord) Not Shown	1
46	2120165	Spacer 0.503 X .69 X 0.250	2	98	0508142	Anti-Rotation Plate (not shown)	1
47	2120220	Spacer, .50 Od X .26 Id X .50 Lg	2				
48	2120233	Spacer, .252 Id X .5 Od X .925 Lg	2				
49	2120262	Sleeve Bearing, .50" Od X .640" Lg	2				
50	2140101	Adhesive / Sealant - Rtv	A/R				
51	2140125	Lubricant, White, Ptfе	A/R				
52	2150181	Sprocket, 25B20 1/2" Bore	1				

* Available In Packages Of 10 (Ten)

WIRING DIAGRAM

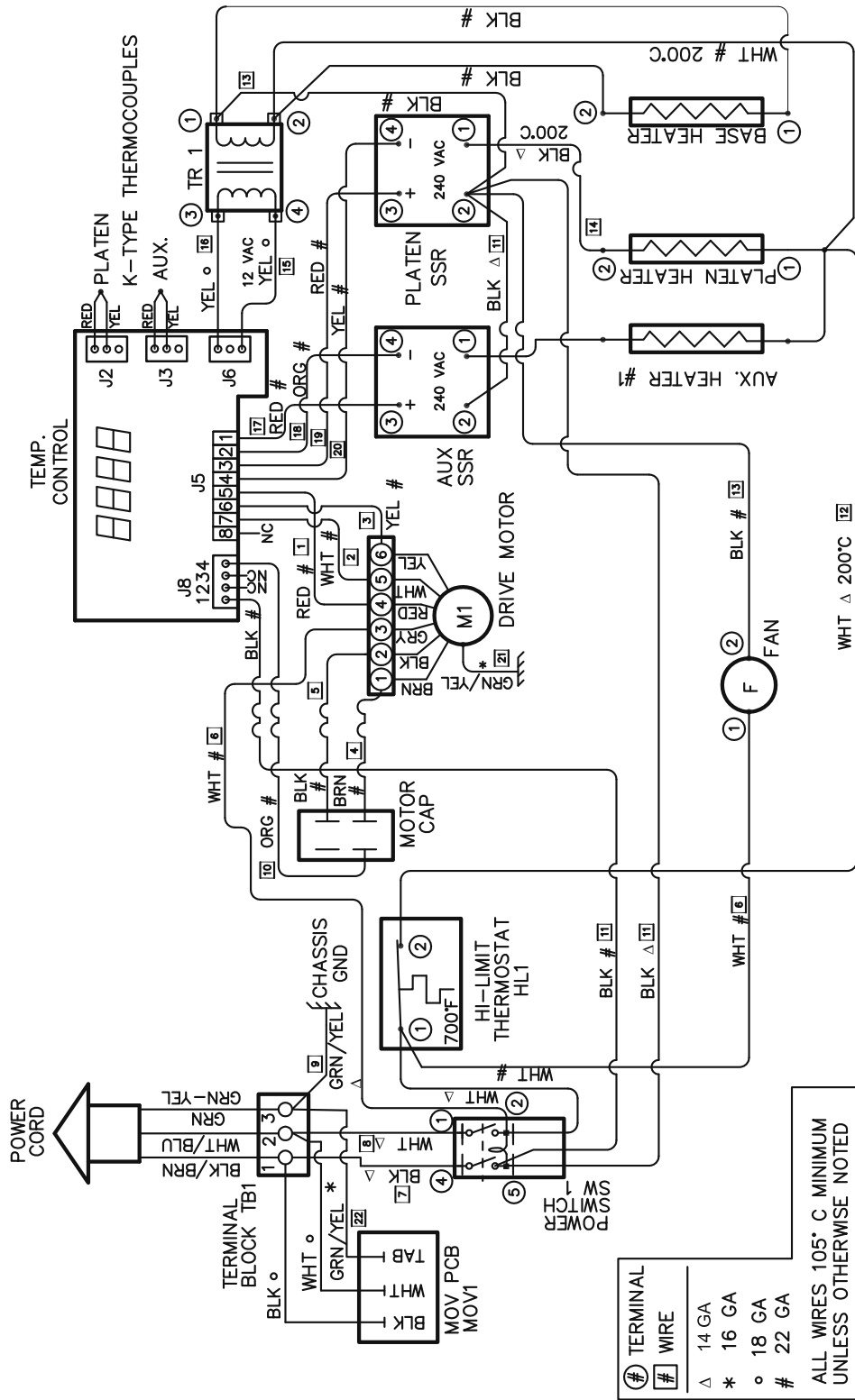

LIMITED WARRANTY

Equipment manufactured by A.J. Antunes & Co. (Antunes) has been constructed of the finest materials available and manufactured to high quality standards. These units are warranted to be free from electrical and mechanical defects for a period of one (1) year from date of purchase under normal use and service, and when installed in accordance with manufacturer's recommendations. To insure continued operation of the units, follow the maintenance procedures outlined in the Owner's Manual. During the first 12 months, electro-mechanical parts, non-overtime labor, and travel expenses up to 2 hours (100 miles/160 km), round trip from the nearest Authorized Service Center are covered. During the first 24 months, coverage for parts only to include the following components: Generator Casting, Solid State Control, and Motor.

1. This warranty does not cover cost of installation, defects caused by improper storage or handling prior to placing of the Equipment. This warranty does not cover overtime charges or work done by unauthorized service agencies or personnel. This warranty does not cover normal maintenance, calibration, or regular adjustments as specified in operating and maintenance instructions of this manual, and/or labor involved in moving adjacent objects to gain access to the equipment. This warranty does not cover consumable/wear items. This warranty does not cover damage to the Load Cell or Load Cell Assembly due to abuse, misuse, dropping of unit/shock loads or exceeding maximum weight capacity (4 lbs). This warranty does not cover water contamination problems such as foreign material in water lines or inside solenoid valves. It does not cover water pressure problems or failures resulting from improper/incorrect voltage supply. This warranty does not cover Travel Time & Mileage in excess of 2 hours (100 miles/160 km) round trip from the nearest authorized service agency.
2. Antunes reserves the right to make changes in design or add any improvements on any product. The right is always reserved to modify equipment because of factors beyond our control and government regulations. Changes to update equipment do not constitute a warranty charge.
3. If shipment is damaged in transit, the purchaser should make a claim directly upon the carrier. Careful inspection should be made of the shipment as soon as it arrives and visible damage should be noted upon the carrier's receipt. Damage should be reported to the carrier. This damage is not covered under this warranty.
4. Warranty charges do not include freight or foreign, excise, municipal or other sales or use taxes. All such freight and taxes are the responsibility of the purchaser.
5. THIS WARRANTY IS EXCLUSIVE AND IS IN LIEU OF ALL OTHER WARRANTIES, EXPRESSED OR IMPLIED, INCLUDING ANY IMPLIED WARRANTY OR MERCHANTABILITY OR FITNESS FOR A PARTICULAR PURPOSE, EACH OF WHICH IS HEREBY EXPRESSLY DISCLAIMED. THE REMEDIES DESCRIBED ABOVE ARE EXCLUSIVE AND IN NO EVENT SHALL ANTUNES BE LIABLE FOR SPECIAL CONSEQUENTIAL OR INCIDENTAL DAMAGES FOR THE BREACH OR DELAY IN PERFORMANCE OF THIS WARRANTY.



U.S. Headquarters

Carol Stream, Illinois
Phone: (630) 784-1000
Toll Free: (800) 253-2991
Fax: (630) 784-1650

China Facility

Suzhou, China
Phone: 86-512-6841-3637
Toll Free: 86-512-6841-3907
Fax: 400-0-7878-22