

MANUFACTURING

NUMBERS:

9600200
9600202
9600210
9600212
9600214
9600215
9600217
9600218



Antunes Foodservice Equipment

A BRAND OF A.J. ANTUNES & CO.

roundup
ANTUNES FOODSERVICE EQUIPMENT

CORN COOKER

Models CCC-20

Series 9600200



P/N 1010634 Rev. I 03/06



Owner's Manual

TABLE OF CONTENTS

Owner Information	2	Equipment Setup	6
General	2	Operating Instructions	7
Warranty Information	2	Unsold Corn.....	7
Important Safety Information	3	Operation	7
Service/Technical Assistance	3	Technical Theory of Operation	8
Dimensions	5	Cleaning Daily	8
Electrical Ratings.....	5	Maintenance	8
Specifications	5	Troubleshooting	9
Capacity.....	5	Replacement Parts	10
Shipping Weight	5	Wiring Diagram	13
Electrical Cord & Plug Configurations	5	LIMITED WARRANTY	Back Cover
Installation	6		
Unpacking.....	6		

OWNER INFORMATION

General

The Roundup Corn Cooker is designed for cooking corn on the cob using controlled low cooking temperature. This controlled low temperature cooking is important in maintaining the taste, appearance and aroma of fresh cooked corn-on-the-cob.

The cooking temperature is approximately 155° - 165°F (68° - 74°C). When cooked in this temperature range, corn can typically be held up to six hours and still retain the natural corn-on-the-cob flavor, appearance and firmness of the kernels.

This manual provides the safety, installation and operating procedures for the Corn Cooker. We recommend that all information contained in this manual be read prior to installing and operating the unit.

Your Corn Cooker is manufactured from the finest materials available and is assembled to Roundup's strict quality standards. This unit has been tested at the factory to ensure dependable trouble-free operation.

Warranty Information

Please read the full text of the Limited Warranty in this manual.

If the unit arrives damaged, contact the carrier immediately and file a damage claim with them. Save all packing materials when filing a claim. Freight damage claims are the responsibility of the purchaser and are not covered under warranty.

The warranty does not extend to:

- Damages caused in shipment or damage as result of improper use.
- Installation of electrical service.
- Normal maintenance as outlined in this manual.
- Malfunction resulting from improper maintenance.
- Damage caused by abuse or careless handling.
- Damage from moisture into electrical components
- Damage from tampering with, removal of, or changing any preset control or safety device.

**IMPORTANT! Keep these instructions for future reference.
If the unit changes ownership, be sure this manual accompanies the equipment.**

OWNER INFORMATION (continued)

Service/Technical Assistance

If you experience any problems with the installation or operation of your unit, contact your local Roundup Authorized Service Agency.

Fill in the information below and have it handy when calling your authorized service agency for assistance. The serial number is on the specification plate located on the unit.

Purchased From: _____

Date of Purchase: _____

Model No.: _____

Serial No.: _____

Mfg. No.: _____

Refer to the service agency directory included with your unit.

Authorized Service Agency

Name: _____

Phone No.: _____

Address: _____

Use only genuine Roundup replacement parts in this unit. Use of replacement parts other than those supplied by the manufacturer will void the warranty. Your Authorized Service Agency has been factory trained and has a complete supply of parts for this unit.

You may also contact the factory at 1-800-253-2991 if you have trouble locating your local authorized service agency.

IMPORTANT SAFETY INFORMATION

Throughout this manual, you will find the following safety words and symbols that signify important safety issues with regards to operating or maintaining the equipment.

WARNING

GENERAL WARNING. Indicates information important to the proper operation of the equipment. Failure to observe may result in damage to the equipment and/or severe bodily injury or death.

CAUTION

GENERAL CAUTION. Indicates information important to the proper operation of the equipment. Failure to observe may result in damage to the equipment.

WARNING

ELECTRICAL WARNING. Indicates information relating to possible shock hazard. Failure to observe may result in damage to the equipment and/or severe bodily injury or death.

WARNING

HOT SURFACE WARNING. Indicates information important to the handling of equipment and parts. Failure to observe caution could result in personal injury.

IMPORTANT SAFETY INFORMATION (continued)

In addition to the warnings and cautions in this manual, use the following guidelines for safe operation of the unit.

- Read all instructions before using equipment.
- For your safety, the equipment is furnished with a properly grounded cord connector. Do not attempt to defeat the grounded connector.
- Install or locate the equipment only for its intended use as described in this manual. Do not use corrosive chemicals in this equipment.
- Do not operate this equipment if it has a damaged cord or plug, if it is not working properly, or if it has been damaged or dropped.
- This equipment should be serviced by qualified personnel only. Contact the nearest Roundup authorized service facility for adjustment or repair.
- Do not block or cover any openings on the unit.
- Do not immerse cord or plug in water.
- Keep cord away from heated surfaces.
- Do not allow cord to hang over edge of table or counter.

The following warnings and cautions appear throughout this manual and should be carefully observed.

- Turn the unit off, disconnect the power source and allow unit to cool down before performing any service or maintenance on the unit.

- The procedures in this chapter may include the use of chemical products. These chemical products will be highlighted with bold face letters followed by the abbreviated HCS (Hazard Communication Standard). See Hazard Communication Standard manual for the appropriate Material Safety Data Sheets (MSDS).
- The unit should be grounded according to local electrical codes to prevent the possibility of electrical shock. It requires a grounded receptacle with separate electrical lines, protected by fuses or circuit breaker of the proper rating.
- All electrical connections must be in accordance with local electrical codes and any other applicable codes.
- **WARNING ELECTRICAL SHOCK HAZARD. FAILURE TO FOLLOW THESE INSTRUCTIONS COULD RESULT IN SERIOUS INJURY OR DEATH.**
 - Electrical ground is required on this appliance.
 - Do not modify the power supply cord plug. If it does not fit the outlet, have a proper outlet installed by a qualified electrician.
 - Do not use an extension cord with this appliance.
 - Check with a qualified electrician if you are in doubt as to whether the appliance is properly grounded.

SPECIFICATIONS

Electrical Ratings

Model & Mfg. No.	Voltage	Watts	Amps	Hertz
CCC-20CF 9600200	120	1750	15.0	50/60
CCC-20HC 9600202	208, 220-240	2090	10.0, 9.5 - 9.0	50/60
CCC-20CF 9600210	120	1750	15.0	50/60
CCC-20HC 9600212	208, 202-240	2090	10.0, 9.5 - 9.0	50/60
CCC-20HC 9600214	208, 220-240	2090	10.0, 9.5 - 9.0	50/60
CCC-20HC 9600215 (Mfg. China)	208, 220-240	2090	10.0, 9.5 - 9.0	50/60
CCC-20CF 9600217 (Mfg. China)	120	1750	15.0	50/60
CCC-20 9600218 (China Only)	208, 220-240	2090	10.0, 9.5 - 9.0	50/60

Electrical Cord & Plug Configurations

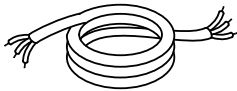
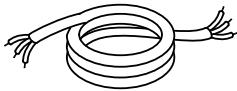
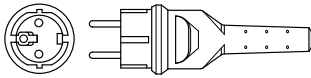
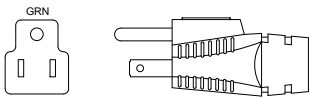
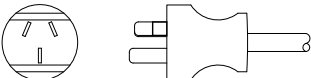
Letter Code*	Description	Configuration
C	Commercial Cord	
H	Harmonized Cord	
(H)C**	CEE 7/7, 16 Amp., 250 VAC (Assembly Only).	
(C)F***	5-15P, 15 Amp., 120 VAC., Non - Locking (Assembly Only).	
	AS3112 15 Amp., Australia (Harmonized Cord)	

** Indicates that the plug comes with a Harmonized Cord
 *** Indicates that the plug comes with a Commercial Cord

Capacity

Quantity-eighty 3" ears of corn

Shipping Weight

30 lbs. (13.6 kilos)

Dimensions

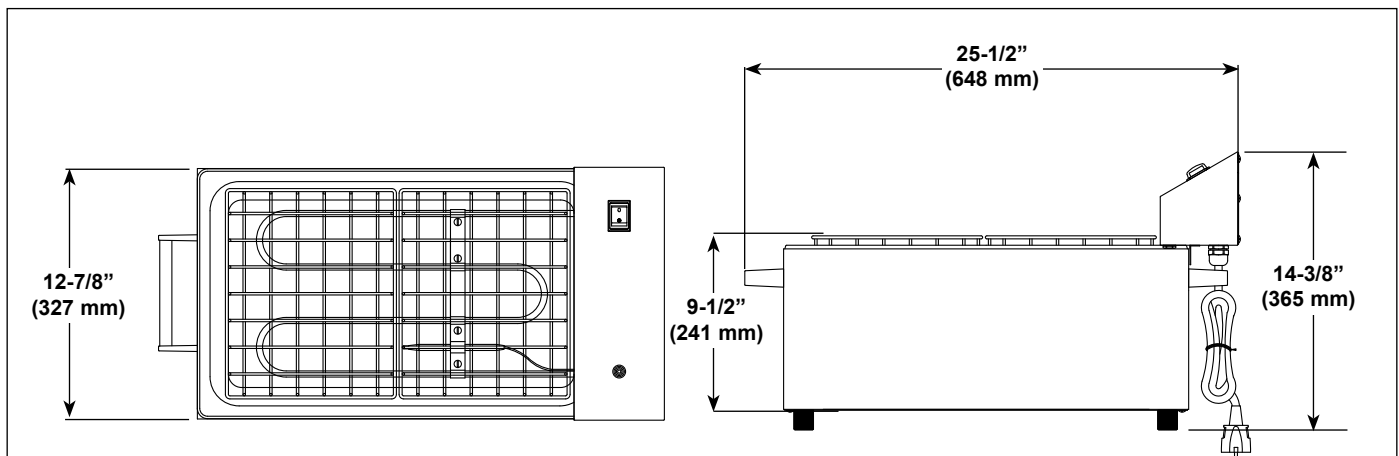

INSTALLATION

Unpacking

1. Remove unit and all packing materials from shipping carton.
2. Open the large box. Remove all packing materials and protective coverings from the unit and parts.
3. Wash baskets in soap and water. Wipe all surfaces of the unit with a hot damp cloth.

NOTE: Do not use a dripping wet cloth. Wring out before use.

4. Install baskets into unit.

NOTE: If any parts are missing or damaged, contact Antunes Technical Service IMMEDIATELY at 1-877-392-7854.

Equipment Setup

When placing the unit into service, pay attention to the following guidelines.

- Make sure the controls are positioned at the rear to ensure adequate room for loading and unloading baskets.
- Make sure power to the unit is off and the unit is at room temperature.
- Do not block or cover any openings on the unit.
- Do not immerse cord or plug in water.
- Keep cord away from heated surfaces.
- Do not allow cord to hang over edge of table or counter.
- Connect the unit to the power supply. Refer to the specification plate for the proper voltage.

⚠ CAUTION ⚠

All electrical connections must be in accordance with local electrical codes and any other applicable codes.

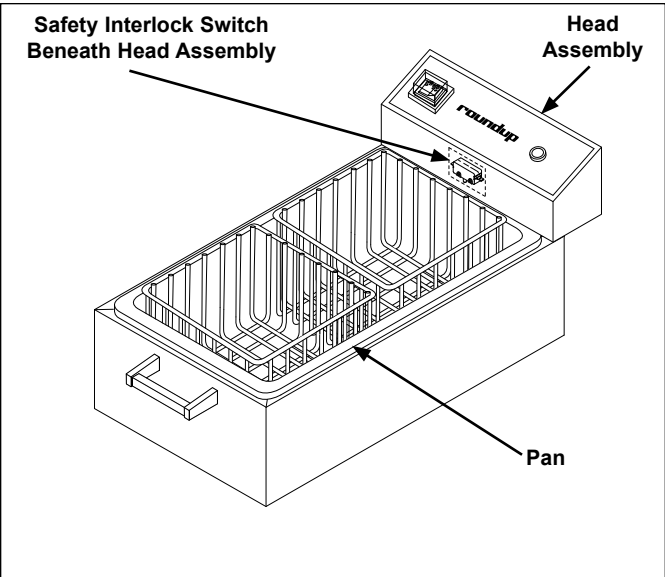

Figure 1. Corn Cooker

⚠ WARNING ⚠

ELECTRICAL SHOCK HAZARD. FAILURE TO FOLLOW THE INSTRUCTIONS IN THIS MANUAL COULD RESULT IN SERIOUS INJURY OR DEATH.

- Electrical ground is required on this appliance.
- Do not modify the power supply cord plug. If it does not fit the outlet, have a proper outlet installed by a qualified electrician.
- Do not use an extension cord with this appliance.
- The unit should be grounded according to local electrical codes to prevent the possibility of electrical shock. It requires a grounded receptacle with separate electrical lines, protected by fuses or circuit breaker of the proper rating.
- Check with a qualified electrician if you are in doubt as to whether the appliance is properly grounded.

OPERATION

Operating Instructions

1. Fill the Pan about half full of hot tap water.
2. Turn the Rocker Switch (power On/Off) ON.

NOTE: If the light on the Rocker Switch does not light up, you must remove and reinstall the Head Assembly onto the pan (Figure 1) to ensure that the Safety Interlock Switch is properly engaged. If the Safety Interlock Switch is not engaged, the Rocker Switch light will not turn on, therefore, the unit will not heat.

3. Load each basket with a full or partial load of corn and immerse the baskets in the pan. Water should completely cover corn. Add more hot water if required.
4. Allow corn to cook approximately 35-45 minutes. The corn is ready to serve when the cob core temperature reaches 150°F (68°C).

NOTE: All models are equipped with a green READY indicator (Figure 2) that lights when water operating temperature is reached.

5. Use the front basket as the serving basket, and the rear basket as the holding basket. Serve corn from the front basket until it is empty, then rotate the corn from the rear to the front basket. This method helps to keep track of which corn has been cooking the longest.

Unsold Corn

Carefully plan and schedule the loading of corn so that only a small amount is left at the end of the day. Any leftover corn can be prepared for use the next day by performing the following steps:

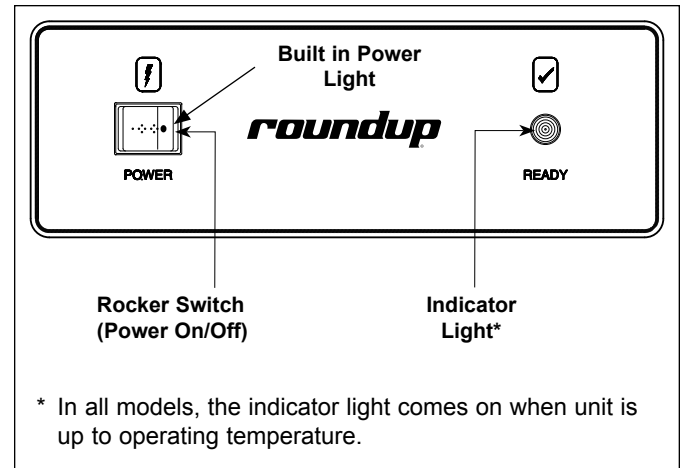

Figure 2. Controls

1. Remove corn from the cooker and place in a container. Handle the corn carefully to prevent damage to the kernels.
2. Cover corn with shaved ice or ice cubes and place in freezer.
3. Reheat the corn the same way as heating uncooked corn.

MAINTENANCE

⚠ WARNING ⚠
Turn the unit off, disconnect the power source and allow the unit to cool down before performing any service or maintenance on the unit.

⚠ CAUTION ⚠
To prevent damage to the unit, do not use abrasive cleaners on the unit.

Cleaning Daily

1. Remove Baskets and the Head Assembly.

2. Empty the Pan of used water. Wash the Baskets and Pan in hot detergent water. Rinse in clear water and dry.
3. Wipe the Head Assembly with a damp cloth, then dry with a clean, dry cloth.
4. Install the Head Assembly onto the pan. **Make sure the Safety Interlock Switch is engaged.**
5. Install the Baskets.

Technical Theory of Operation

When the unit is plugged into the outlet, line voltage flows to the normally open (N.O.) Safety Interlock Switch¹.

Once the Safety Interlock Switch contacts close, line voltage then flows to the input side of the Rocker Switch (Power On/Off). When the Rocker Switch is turned on, line voltage then flows to a normally closed (N.C) capillary bulb style thermostat².

Providing the water temperature within the pan is below 162° F (72° C), the Thermostat calls for heat by supplying line voltage to the Heating Element³.

As the water begins to heat up, the Thermostat's bulb monitors the water temperature. When the water temperature approaches approximately 162° F (72° C), the Thermostat's contacts open and turn off the Heating Element.

Simultaneously, the "Green" indicator light lights up to indicate that the water is up to temperature. The heat-

ing circuit then cycles on and off as needed, even at idle. If the heating circuit continues to call for heat, the water will begin to boil & overcook the corn.

NOTE: If the water boils and begins to overcook the corn, the root cause must be determined & corrected. Refer to the Troubleshooting section of this manual.

1 Safety Interlock Switch: The Safety Interlock Switch is used to prevent operation of the Heating Element in the event the Head Assembly is not properly seated onto the pan, or if the unit is operating without the pan. The switch has an actuating plunger which protrudes from beneath the Head Assembly. Provided the Head Assembly is properly seated onto the pan, the weight of the Head Assembly applies pressure to the actuating plunger, thereby closing its contacts.

2 Thermostat: The Thermostat is fixed to maintain approximately 162 F (72 C) water temperature.

3 Heating Element: The Heating Element must only be operated while submersed in water.

TROUBLESHOOTING

⚠ WARNING ⚠

To avoid possible personal injury and/or damage to the unit, inspection, test and repair of electrical equipment should be performed by qualified service personnel. The unit should be unplugged when servicing, except when electrical tests are required. Use extreme care during electrical circuit tests. Live circuits will be exposed.

Problem	Possible Cause	Corrective Action
Rocker Switch (power On/Off) is ON, but the unit does not heat and the light on the Rocker Switch is OFF.	The power cord is not correctly plugged in.	Plug power Cord into appropriate outlet.
	Circuit Breaker tripped.	Reset the Circuit Breaker.
	Damaged Power Cord.	Replace Power Cord.
	Loose, burnt, or broken wires in circuit.	Tighten wires and replace if burned or charred.
	Inoperable Rocker Switch.	Replace Rocker Switch.
	Safety Interlock Switch not engaged.	Reposition the Head Assembly to engage the Safety Interlock Switch according to the operating instructions in this manual..
Unit overheats or overcooks (water boils).	Inoperable Thermostat.	Replace the Thermostat
	Water level is too low.	Add water so that the corn is completely covered.
Unit under cooks the corn.	Inoperable Thermostat.	Replace the Thermostat.
Rocker Switch (power On/Off) is ON, the unit does not heat, but the light on the Rocker Switch is ON.	Inoperable Heating Element	Replace the Heating Element.
	Inoperable Thermostat.	Replace the Thermostat.
	Loose, burnt, or broken wires in circuit.	Replace wires.

REPLACEMENT PARTS

Item	Part No.	Description	Quantity	
			Mfg. # 9600200, 202, 210, 212, & 214	Mfg. # 9600215, 9600217, & 9600218
1	0800103	Basket, Corn	2	-
	0800380	Basket, Corn	-	2
2	0500233	Clamp, Heater	1	-
	0504108	Clamp, Heater	-	1
3	403K121	Thermostat Kit (Incl. #20)	1	1
4	0500230	Clamp	1	-
	0504106	Clamp	-	1
5	0021027	Base Plate Weldment	1	-
	0021471	Base Plate Weldment	-	1
6	210K230	Bumper Leg Kit (Incl. Qty. 4 Legs)	1	1
7	2100106	Handle, Grip	1	1
8	0502994	Housing, Base	1	1
	0504112	Housing, Base	-	1
9	0021025	Pan Weldment	1	-
	0021470	Pan Weldment	-	1
10	401K106	Rocker Switch, Power On/Off, 230V (Incl. #12)	1	1
	401K107	Rocker Switch, Power On/Off, 120V (Incl. #12)	1	1
11	4030298	Element, Heating, 1920W, 230V	1	-
	4030369	Element, Heating 1920W, 230V	1	-
	4030297	Element, Heating, 1750W, 120V	-	1
	4030368	Element, Heating, 1750W, 120V	-	1
12	0400291	Splashguard	1	1
13	4060315	Indicator Light, Green, 230V (Mfg. Nos. 9600202)	1	1
	4060331	Indicator Light, Green, 120V (Mfg. Nos. 9600200)	1	1
14	1000943	Label, Head Housing	1	1
15	0021024	Head Housing Weldment	1	-
	0021469	Head Housing Weldment	-	1
16	0700453	Power Cord, CEE 7/7	1	1
	0700463	Power Cord, NEMA 5-15P	1	1
	0700694	Power Cord, Harmonized w/ Australian Plug 15 Amp.	-	1
17	040K251	Strain Relief Kit	1	1
18	0502940	Panel, Access	1	-
	0504109	Panel, Access	-	1
19	7000136	Terminal Block	1	1
20	020K195	Gasket Seal Kit (Incl. plate cover inner, plate cover outer, gasket seat and Qty. 2 screws)	1	2
21	0400290	Insulator, Electrical	2	2
22	401K101	Interlock Switch Kit (Incl. #24)	1	1
23	1000942	Label, Wiring Diagram	1	1
24	020P115	O-Ring	1	1
25	306P102*	Washer, Internal Tooth, #6	1	1
26	306P104*	Screw, #6-32 x 1/4"	1	1
27	306P105*	Screw, #6-32 x 1/2"	1	1
28	306P107*	Nut, Hex, Acorn, #6-32	1	1
29	306P108*	Screw, #6-32 x 1"	1	1
30	306P123*	Screw, #6-32 x 7/8"	1	1
31	306P130*	Nut, Hex, KEPS, #6-32	1	1
32	308P103*	Screw, #8-32 x 1/4"	1	1
33	308P115*	Screw, #8-32 x 3/8"	1	1
34	308P124*	Screw, One-way, #8-32 x 1/2"	1	1
35	308P143*	Nut, Hex, KEPS, #8-32	1	1

REPLACEMENT PARTS (continued)

Item	Part No.	Description	Quantity	
			Mfg. # 9600200, 202, 210, 212, & 214	Mfg. # 9600215, 9600217, & 9600218
36	310P102*	Lockwasher, #10	1	1
37	310P123*	Screw, #10-24 x 1/2"	1	1
39	310P146*	Nut, Hex, KEPS, #10-32	1	1
NS	0011046	Base Housing Assy.	1	1
	0011769	Base Housing Assy.		1
NS	7000162	Head Assy. Kit, 120V	1	1
	7000163	Head Assy. Kit, 230V	1	1
	7000164	Head Assy. Kit, 230V (China)	1	1
NS	406P107*	Cable Ties	1	1

** Only available in packages of 10.*

REPLACEMENT PARTS (continued)

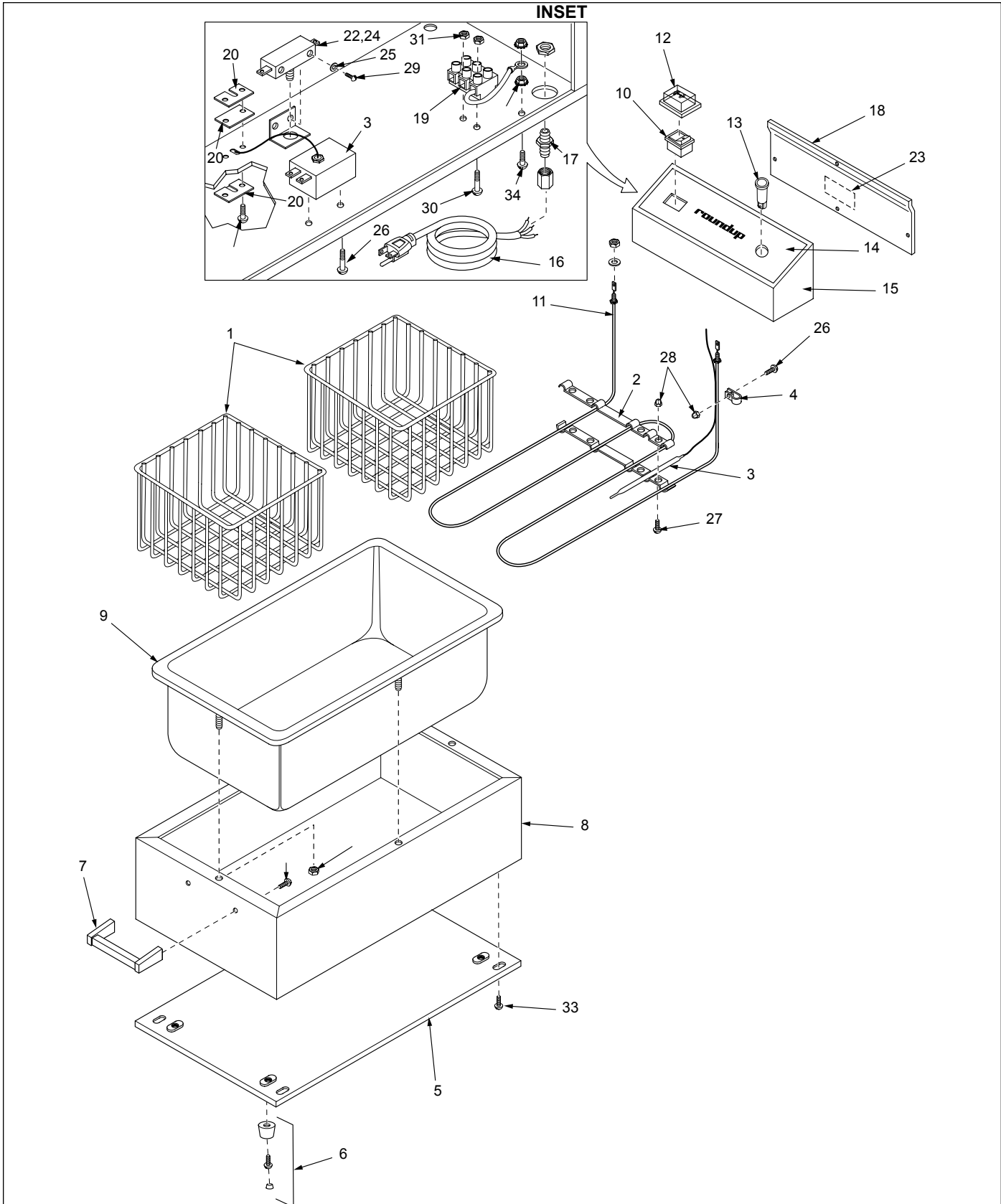

WIRING DIAGRAM

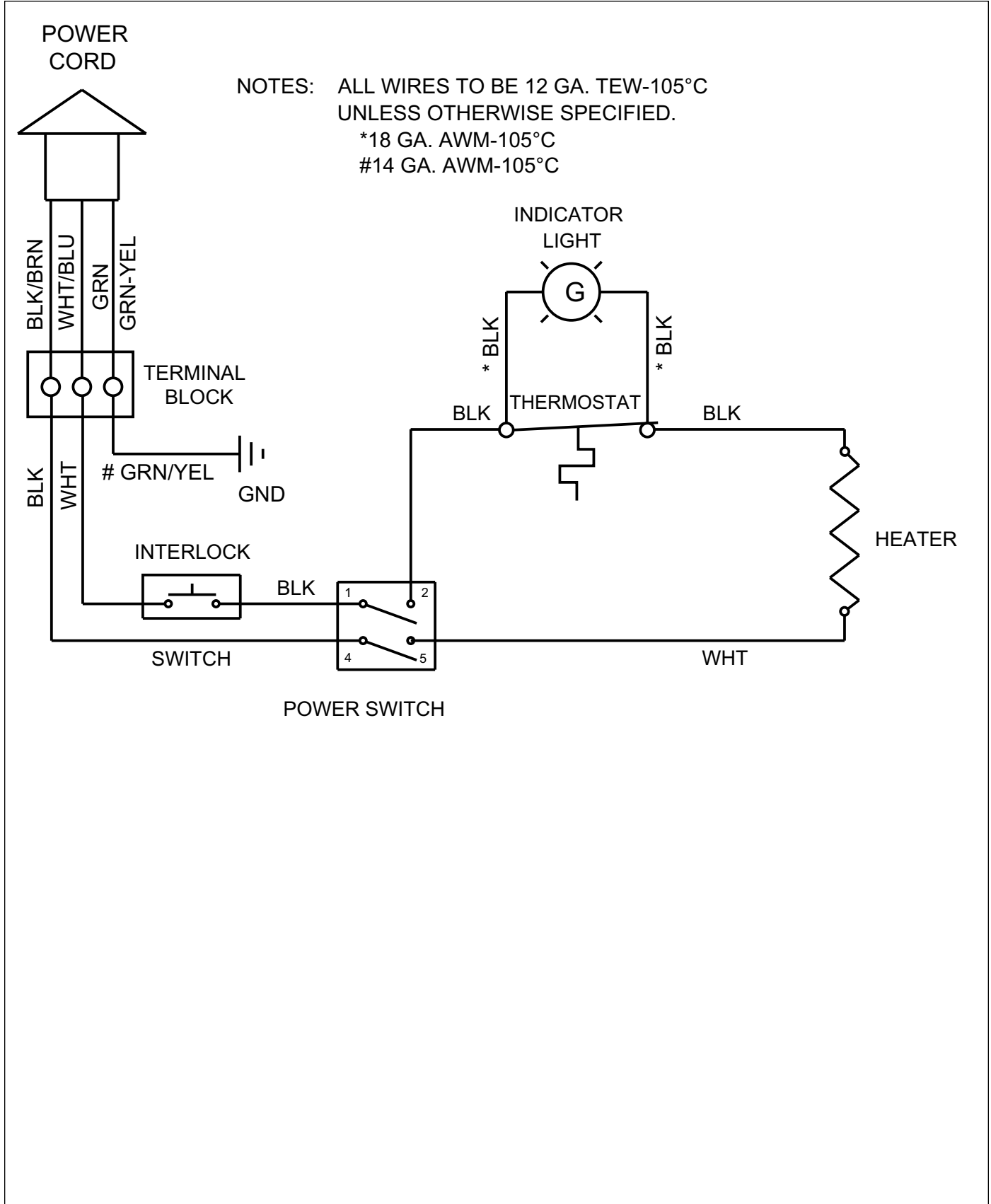

NOTES: ALL WIRES TO BE 12 GA. TEW-105°C
UNLESS OTHERWISE SPECIFIED.
*18 GA. AWM-105°C
#14 GA. AWM-105°C

LIMITED WARRANTY

Equipment manufactured by Roundup Food Equipment Division of A.J. Antunes & Co. has been constructed of the finest materials available and manufactured to high quality standards. These units are warranted to be free from mechanical and electrical defects for a period of one year from date of purchase or 18 months from shipment from factory, whichever occurs first, under normal use and service, and when installed in accordance with manufacturer's recommendations.

To insure continued proper operation of the units, follow the maintenance procedure outlined in the Owner's Manual.

1. This warranty does not cover cost of installation, defects caused by improper storage or handling prior to placing of the Equipment. This warranty does not include overtime charges or work done by unauthorized service agencies or personnel. This warranty does not cover normal maintenance, calibration, or regular adjustments as specified in operating and maintenance instructions of this manual, and/or labor involved in moving adjacent objects to gain access to the Equipment. This warranty does not cover consumable items such as the Platen, Release Sheets, Conveyor Belt Wraps, gaskets, O-rings, light bulbs, nor does it cover water contaminant problems such as foreign material in water lines or inside solenoid valves. It does not cover water pressure problems. **This warranty does not pay travel, mileage, or any other charges for an Authorized Service Agency to reach the equipment location.**
2. Roundup reserves the right to make changes in design or add any improvements on any product. The right is always reserved to modify equipment because of factors beyond our control and government regulations. Changes to update equipment do not constitute a warranty charge.
3. If shipment is damaged in transit, the purchaser should make a claim directly upon the carrier. Careful inspection should be made of the shipment as soon as it arrives and visible damage should be noted upon the carrier's receipt. Damage should be reported to the carrier. This damage is not covered under this warranty.
4. Warranty charges do not include freight or foreign, excise, municipal or other sales or use taxes. All such freight and taxes are the responsibility of the purchaser.
5. THIS WARRANTY IS EXCLUSIVE AND IS IN LIEU OF ALL OTHER WARRANTIES, EXPRESSED OR IMPLIED, INCLUDING ANY IMPLIED WARRANTY OR MERCHANTABILITY OR FITNESS FOR A PARTICULAR PURPOSE, EACH OF WHICH IS HEREBY EXPRESSLY DISCLAIMED. THE REMEDIES DESCRIBED ABOVE ARE EXCLUSIVE AND IN NO EVENT SHALL ROUNDUP BE LIABLE FOR SPECIAL CONSEQUENTIAL OR INCIDENTAL DAMAGES FOR THE BREACH OR DELAY IN PERFORMANCE OF THIS WARRANTY.



A.J. Antunes & Co.
Headquarters/Manufacturing
180 Kehoe Boulevard
Carol Stream, Illinois 60188 USA
Phone (630) 784-1000
Toll Free (800) 253-2991
Fax: (630) 784-1650

Antunes Equipment
Manufacturing (Suzhou) Ltd.,
9 Hou Ju Road, Building #24,
S&T Park, SND
Suzhou, Jiangsu, China 215011
Phone: 86-512-6841-3637
Fax: 86-512-6841-3907