

# Egg Station

Model ES-600, ES-602,  
ES-604, & ES-1200  
owner's manual

**Manufacturing Numbers:**

9300530, 9300531, 9300532, 9300534, 9300571,  
9300574, 9300575, 9300577, 9300593, 9300598,  
9300621, 9300622, 9300623



## CONTENTS

<b>General</b>	<b>2</b>
<b>Warranty Information</b>	<b>2</b>
<b>Service/Technical Assistance</b>	<b>2</b>
<b>Important Safety Information</b>	<b>3</b>
<b>Warnings</b>	<b>3</b>
<b>Specifications</b>	<b>4</b>
<b>Installation</b>	<b>5</b>
Unpacking	5
Equipment Setup	5
<b>Operating Instructions</b>	<b>6</b>
Preparing Unit	6
Egg Cooking Procedure	6
Bacon Timer*	6
(All units EXCEPT Mfg. No. 9300534)	7
<b>Maintenance</b>	<b>8</b>
Daily Cleaning	8
Checking Cycle Times (Monthly)	8
(All units EXCEPT Mfg. No. 9300534)	8
Checking Cycle Times (Monthly)	8
(Mfg. No. 9300534 ONLY)	8
Checking Grill Platen Temperature	9
<b>Troubleshooting</b>	<b>10</b>
Control Board LEDs	11
Green LED Blink Codes	11
<b>Wiring Diagram</b>	<b>12</b>
<b>Replacement Parts</b>	<b>13</b>

## GENERAL

This product cooks/steams eggs (refrigerated) in approximately 150 seconds and reheats sliced meat for sandwiches. Eggs within the Egg Rings are cooked with a combination of heat and steam. With the cover closed, water is poured into a trough on the cover and drips onto a hot Platen, producing steam and cooking the eggs. The unit is equipped with audio/visual signals for operation.

This manual provides the safety, installation, and operating procedures for the Egg Station. We recommend that all information contained in this manual be read prior to installing and operating the unit.

Your Egg Station is manufactured from the finest materials available, assembled to our strict quality standards, and tested at the factory to ensure dependable trouble-free operation.

## WARRANTY INFORMATION

Please read the full text of the Limited Warranty printed on the back cover of this manual.

If the unit arrives damaged, contact the carrier immediately and file a damage claim with them. Save all packing materials when filing a claim. Freight damage claims are the responsibility of the purchaser and not covered under warranty.

The warranty does not extend to:

- Damages caused in shipment or damage as result of improper use.
- Installation of electrical service.
- Installation, calibration, or adjustment.
- Normal maintenance outlined in this manual.
- Consumable parts such as Egg Rings, gaskets, rubber feet, labels, O-rings, light bulbs, etc.
- Malfunction resulting from improper service or maintenance.
- Damage caused by improper installation, abuse, or careless handling.
- Damage from moisture getting into electrical components.
- Damage from tampering with, removal of, or changing any preset control or safety device.
- Damage caused by parts or components not provided by A.J. Antunes & Co.

## SERVICE/TECHNICAL ASSISTANCE

If you experience any problems with the installation or operation of your system, contact Antunes & Co. at 1-630-784-1000, or toll free in the United States at 1-800-253-2991.

Fill in the information in the next column and have it handy when calling for assistance. The serial number is on the specification plate located on the system.

---

Purchased From

---

Date of Purchase

---

Model Number

---

Serial Number

---

Mfg. Number

Use only genuine Antunes replacement parts in this unit. Use of replacement parts other than those supplied by the manufacturer will void the warranty.

### IMPORTANT

**A.J. Antunes & Co. reserves the right to change specifications and product design without notice. Such revisions do not entitle the buyer to corresponding changes, improvements, additions or replacements for previously purchased equipment.**

### IMPORTANT

**Keep these instructions for future reference. If the unit changes ownership, be sure this manual accompanies the equipment.**

## IMPORTANT SAFETY INFORMATION

Use the following guidelines for safe operation of the unit.

- Read all instructions before using equipment.
- For your safety, the equipment is furnished with a properly grounded cord connector. Do not attempt to defeat the grounded connector.
- Install or locate the equipment only for its intended use as described in this manual. Do not use corrosive chemicals in this equipment.
- Do not operate this equipment if it has a damaged cord or plug, if it is not working properly, or if it has been damaged or dropped.
- This equipment should be serviced by qualified personnel only. Contact your nearest Authorized Service Agency for adjustment or repair.
- Do not block or cover any openings on the unit.
- Do not immerse cord or plug in water.
- Keep cord away from heated surfaces.
- Do not allow cord to hang over edge of table or counter.

The following warnings and cautions appear throughout this manual and should be carefully observed.

- Turn the power off, unplug the power cord, and allow unit to cool down before performing any service or maintenance on the unit.
- The equipment should be grounded according to local electrical codes to prevent the possibility of electrical shock. It requires a grounded receptacle with separate electrical lines, protected by fuses or circuit breaker of the proper rating.
- All electrical connections must be in accordance with local electrical codes and any other applicable codes.
- Do not clean this appliance with a water jet.

## WARNINGS

Be advised of the following warnings when operating and performing maintenance on this unit.

- If the supply cord is damaged, it must be replaced by the manufacturer or its service agent or a similarly qualified person in order to avoid a hazard.
- Do not modify the power supply cord plug. If it does not fit the outlet, have a proper outlet installed by a qualified electrician.
- Do not use an extension cord with this appliance.
- Electrical ground is required on this appliance.
- Check with a qualified electrician if you are unsure if the appliance is properly grounded.
- If a chemical cleaner is used, be sure it is safe to use on cast aluminum. Observe all precautions and warnings on product label.
- Inspection, testing, and repair of electrical equipment should only be performed by qualified service personnel.
- This equipment is to be installed to comply with the basic plumbing code of the Building Officials and Code Administrators, Inc. (BOCA) and the Food Service Sanitation Manual of the Food and Drug Administration (FDA).
- Do not use abrasive materials. The use of these may cause damage to the stainless steel finish.
- Chlorides or phosphates in cleaning agents (e.g. bleach, sanitizers, degreasers or detergents) could cause permanent damage to stainless steel equipment. The damage is usually in the form of discoloration, dulling of metal surface finish, pits, voids, holes, or cracks. This damage is permanent and not covered by warranty.

The following tips are recommended for maintenance of your stainless steel equipment:

- Always use soft, damp cloth for cleaning, rinse with clear water and wipe dry. When required, always rub in direction of metal polish lines.
- Routine cleaning should be done daily with soap, ammonia detergent, and water.
- Stains and spots should be sponged using a vinegar solution.
- Finger marks and smears should be rubbed off using soap and water.
- Hard water spots should be removed using a vinegar solution.

# SPECIFICATIONS

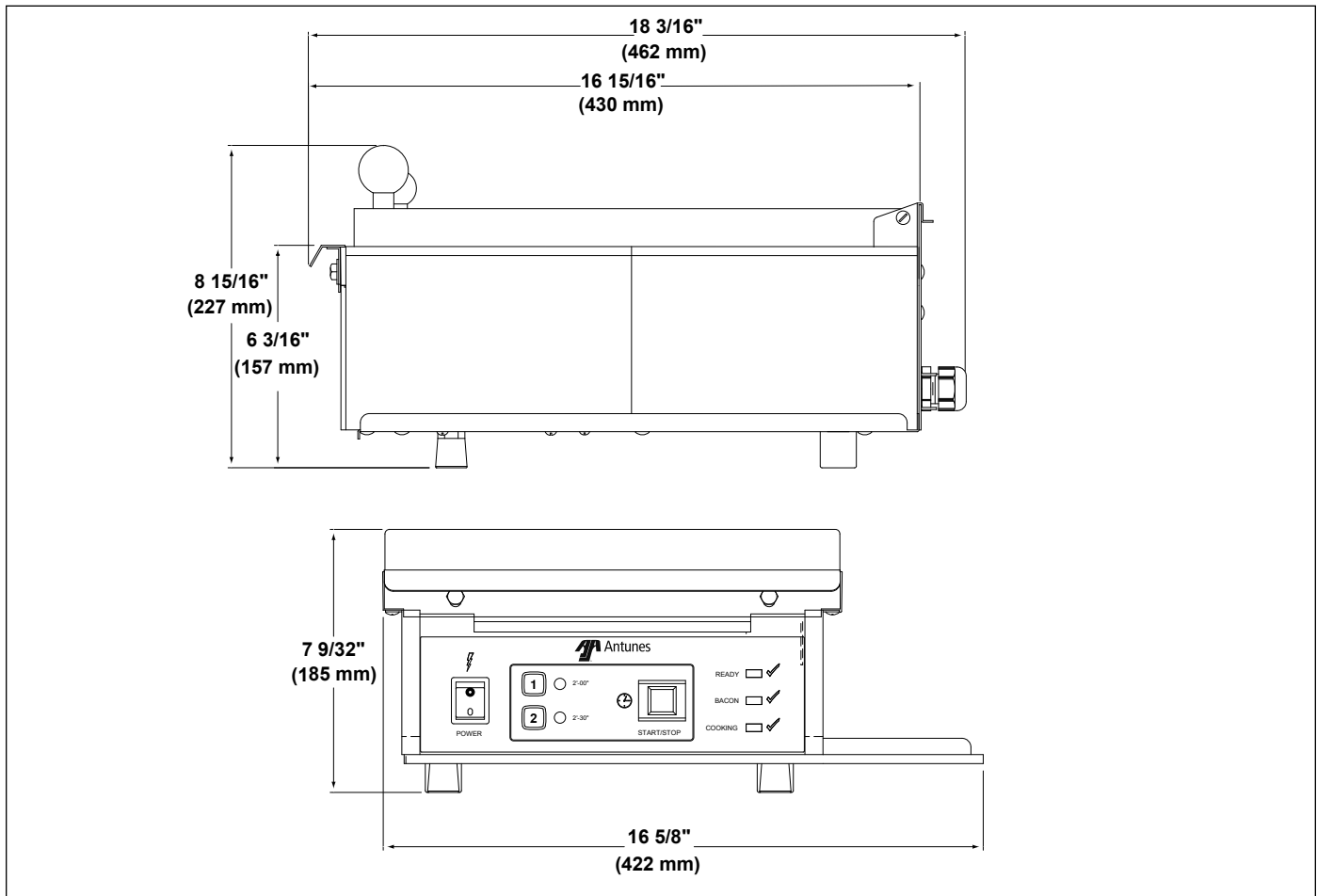

Model & Mfg. No.	Volts	Watts	Amp	Hertz
ES-600 9300530	208	2400	11.5	50/60
ES-600 9300531	208/220 - 240~	2400 / 3150	11.5 / 10.9 - 13.1	50/60
ES-602 9300571 9300577	208	2400	11.5	50/60
ES-604 9300574 9300575	208	2400	11.5	50/60
ES-1200 9300532 9300534	208	2400	11.5	50/60
ES-604 9300598 9300622 9300623 9300593 9300621	208/220 - 240~	2400 / 3150	11.5 / 10.9 - 13.1	50/60

Model & Mfg. No.	Description	Configuration
ES-600 9300530 9300531	6-20P, 20 Amp., 250 VAC., Non-Locking (Assembly Only)	
ES-602 9300571 9300577		
ES-604 9300574 9300575 9300593 9300621		
ES-1200 9300532 9300534 9300598 9300622		
ES-1200 9300623		

### Shipping Weight

- ES-600: 48 lbs. (21.7 kg)
- ES-602, ES-604, & ES-1200: 50 lbs. (22.6 kg)

### Net Weight

- ES-600: 41 lbs. (18.6 kg)
- ES-602, ES-604, & ES-1200: 43 lbs. (19.5 kg)

# INSTALLATION

## Unpacking

1. Remove unit and all packing materials from shipping carton.

**NOTE:** If any parts are missing or damaged, contact A.J. Antunes & Co. Technical Service IMMEDIATELY at 1-877-392-7854 (Toll free in the U.S. and Canada) or 630-784-1000.)

2. Remove information packet.
3. Remove all packing materials and protective coverings from the unit.
4. Wipe all surfaces of the unit with a hot damp cloth.

**NOTE:** Do NOT use a dripping wet cloth. Wring it out before use.

5. Clean the Egg Rings, Egg Rack, Top Cover, and Service Pans in hot, soapy water. Rinse in clear water and allow to air dry.
6. Reassemble all parts to unit.

## Equipment Setup

When placing the unit into service, pay attention to the following guidelines:

- Make sure power is off and the unit is at room temperature.
- Do NOT block or cover any openings on the unit.
- Do NOT immerse cord or plug in water.
- Keep cord away from heated surfaces.
- Do NOT allow cord to hang over edge of table or counter.
- Place the unit on a sturdy, level table or other work surface.
- Ensure that the line voltage corresponds to the stated voltage on the unit's specification label. If unsure, have an electrician confirm correct line voltage before connecting unit.
- Place the unit on a sturdy, level surface.
- Make sure the unit is also level so that water does not run from one side to the other. Adjust the legs as needed to level the unit.

### CAUTION

All electrical connections must be in accordance with local electrical codes and any other applicable codes.

### WARNING

- **ELECTRICAL SHOCK HAZARD.** Failure to follow the instructions in this manual could result in serious injury or death.
- Electrical ground is required on this appliance.
- Do NOT modify the power supply cord plug. If it does not fit the outlet, have a proper outlet installed by a qualified electrician.
- Do NOT use an extension cord with this unit.
- The unit should be grounded according to local electrical codes to prevent the possibility of electrical shock. It requires a grounded receptacle with separate electrical lines, protected by fuses or circuit breaker of the proper rating.
- Check with a qualified electrician if you are unsure if the appliance is properly grounded.

### IMPORTANT

When installing the unit, use a leveler to ensure that the table/cart is level and that the unit is level when placed. If necessary, adjust the two front bottom legs of the unit to level it. Failure to level the table and/or unit may result in unevenly cooked product.

# OPERATING INSTRUCTIONS

## Preparing Unit

1. Turn the unit on and allow it to warm up for approximately 20–30 minutes.

**NOTE:** During warm up, the Ready Indicator Light flashes. The Ready Indicator Light stays on once the unit reaches operating temperature.

2. If necessary, install the Top Cover according to Figure 1.
3. Install the Egg Rack by holding it vertically and sliding the pins of the Egg Rack into the slots on the back of the Top Cover.
4. Install the Egg Rings into the Egg Rack (Figure 3). Make sure the Egg Rings are seated flat on the Platen surface.
5. Ensure that the Egg Rack and Top Cover are in the down position while the cooker warms up.
6. Add melted butter (or equivalent) to one Service Pan (if desired) and slide the Service Pan into the tray on right side of unit.
7. Slide the second Service Pan into the tray for use for collecting scraps and unused product (if desired).

## Egg Cooking Procedure

Read these instructions prior to cooking eggs.

1. Make sure the grill is clean and free of all extra butter, oils, or egg product.
2. Raise the Top Cover and brush the Egg Rings and Grill surface with melted butter or equivalent.
3. Crack the eggs into the Egg Rings from right to left as shown in Figure 2, starting at the row closest to the front of the unit.
4. Break the egg yolks if desired and close the Top Cover.
5. Fill the troughs on the Top Cover with warm water until they are completely full. This is very important to get a completely cooked egg with a jelled yolk. Using less water results in under-cooked eggs.
6. Select the desired cooking cycle (Figure 3).

**All units EXCEPT Mfg. No. 9300534:** Use a two-minute cycle for room temperature eggs or the two-and-a-half-minute cycle for refrigerated eggs (Figure 3 top).

**No. 9300534 Only:** Select 6 for six eggs or 12 for twelve eggs (Figure 3 bottom)

7. **All units EXCEPT Mfg. No. 9300534:** If desired, place sliced meat (Canadian bacon, ham, etc.) on the front part of the Platen when Bacon Indicator Light begins to flash and the audio signal sounds (see Bacon Timer in the Operation section of this manual).

8. Press the Start/STOP button to begin the cooking cycle.

**NOTE:** The Cooking Indicator Light will light when the Start/Stop button is pressed and released.

9. At the end of the cycle, when the Cooking Indicator Light turns off, press the Start/Stop button to turn off the audio signal.

10. **All units EXCEPT Mfg. No. 9300534:** Remove the meat from the Platen surface (see the Bacon Timer section of this manual).

11. Open the cover and raise the Egg Rack about 1 inch (26 mm), then drop the rack to loosen the eggs.

12. Raise the Egg Rack completely off the eggs and use a spatula to remove the eggs.

**NOTE:** Refer to Figure 2. Remove eggs starting with the first egg added and finish with the last egg added. This ensures even cooking for all eggs.

13. Scrape and waste from Platen grill surface into the Service Pan.

14. Lower the Egg Rack and Cover. The unit is ready for further cooking.

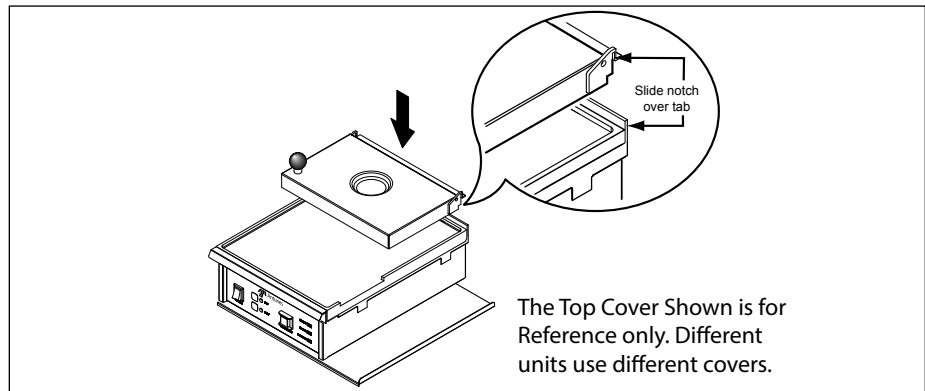

Figure 1. Installing Top Cover

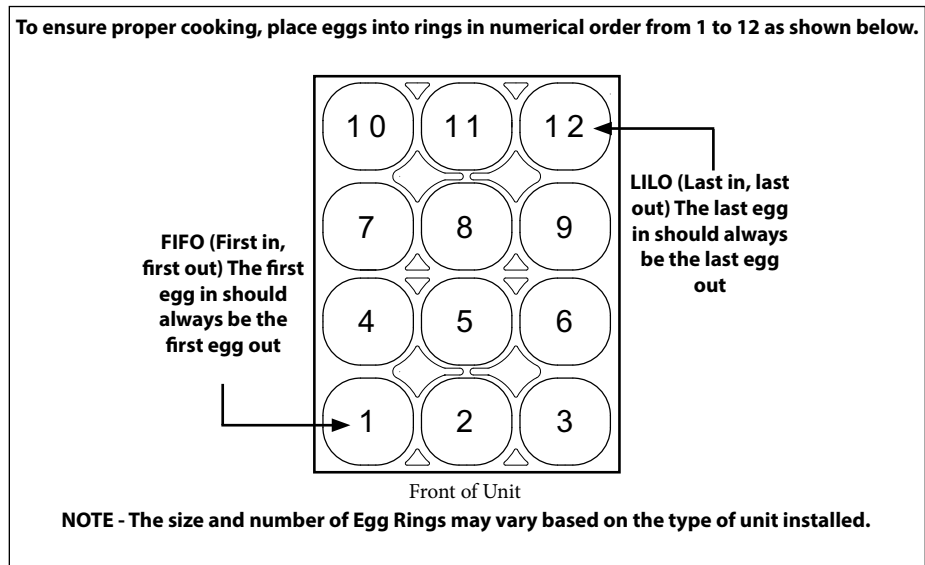
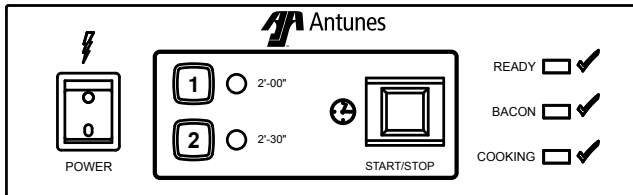
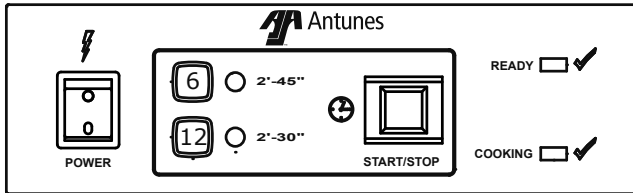

Figure 2. Sample Egg Cooking Procedure



**FOR MFG. NO. 9300530, 532, 571, 574, 575, & 593:**  
 NOTE - THE FOLLOWING ARE FACTORY PRE-SET COOKING TIMES.  
 TIME 1 BUTTON: 2 MINUTE COOKING TIME.  
 TIME 2 BUTTON: 2 MINUTES AND 30 SECONDS COOKING TIME.



**FOR MFG. NO. 9300534 ONLY:**  
 NOTE - THE FOLLOWING ARE FACTORY PRE-SET COOKING TIMES.  
 TIME 6 BUTTON (6 EGGS): 2 MINUTES 45 SECONDS COOKING TIME.  
 TIME 12 BUTTON (12 EGGS): 2 MINUTES 30 SECONDS COOKING TIME.

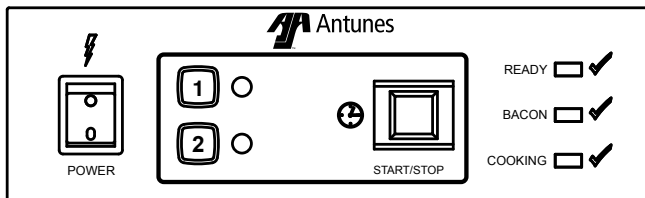

**FOR MFG. NO. 9300621 ONLY:**  
 NOTE - THE FOLLOWING ARE FACTORY PRE-SET COOKING TIMES.  
 TIME 1 BUTTON: 2 MINUTE COOKING TIME.  
 TIME 2 BUTTON: 3 MINUTE TIME.

**Figure 3. Time Selector Switch**

**Bacon Timer\***  
**(All units EXCEPT Mfg. No. 9300534)**

If, during the standby mode, the Bacon Indicator Light is not lit, it means that the Bacon Timer is disabled. To enable the Bacon Timer, with the unit turned on, press the TIME 1 and TIME 2 buttons simultaneously for 3 or more seconds. The Bacon Indicator Light will turn on. The Bacon Timer is now enabled.

To disable the Bacon Timer, press the TIME 1 and TIME 2 buttons simultaneously for 3 or more seconds. The Bacon Indicator Light will turn off. The Bacon Timer is now disabled.

**Using the Bacon Timer**

If the Bacon Timer is enabled, an audio signal will sound for a few seconds and the Bacon Indicator Light will begin to flash 30 seconds before the end of the cooking cycle.

During this time, the product should be placed on the front part of the grill so that it will heat for 30 seconds. The Bacon Indicator Light will continue to flash until the end of the cooking cycle.

\* ES-600 units are designed to operate with the Bacon Timer enabled. ES-602, ES-604 and ES-1200 units are designed to operate with the Bacon Timer disabled.

## MAINTENANCE

### WARNING

Turn the power off, unplug the power cord, and allow the unit to cool down before performing any service or maintenance.

### CAUTION

Chlorides or phosphates in cleaning agents (e.g. bleach, sanitizers, degreasers, or detergents) could cause permanent damage to stainless steel equipment. The damage is usually in the form of discoloration, dulling of metal surface finish, pits, voids, holes, or cracks. This damage is permanent and NOT covered by warranty. The following tips are recommended for maintenance of your stainless steel equipment

- Always use soft, damp cloth for cleaning, rinse with clear water and wipe dry. When required, always rub in direction of metal polish lines.
- Stains and spots should be removed using a vinegar solution.
- Finger marks and smears should be removed using soap and water.
- Hard water spots should be removed using a vinegar solution.

### CAUTION

If a chemical cleaner is used, be sure it is safe to use on cast aluminum. Observe all precautions and warnings on product label.

### Daily Cleaning

1. Turn the unit off, unplug the power cord, and allow the unit to cool down before proceeding.
2. Scrape the Platen surface clean of any residue.
3. Wipe the entire Platen surface clean with damp grill cloth.
4. Wipe the entire cooker cabinet clean with clean, damp cloth.

**NOTE:** Do NOT use a dripping wet cloth. Wring the cloth out before use.

### CAUTION

Grill surfaces will be hot. Care should be taken when operating this piece of equipment.

5. Clean the Egg Rings, Egg Rack, Cover, and Service Pans in hot, soapy water. Rinse these items in clear water and allow to air dry.
6. Reassemble the unit.

### Checking Cycle Times (Monthly) (All units EXCEPT Mfg. No. 9300534)

**NOTE:** A stopwatch is required for this procedure.

1. Turn the unit on and allow it to warm up for 30 minutes.
2. Ensure that the TIME 1 button is lit. If not, press and release the TIME 1 button. This button should now be lit.
3. With the stopwatch in hand, press and release the Start/Stop button and start the stopwatch.
4. Record the time when the Bacon Indicator Light begins to flash (if the Bacon Timer is enabled). Then, record the time when the Cooking Indicator Light turns off.
5. Repeat this test with the TIME 2 button selected.

When set at 2'-00", the Bacon Indicator Light should flash at 1 minute and 30 seconds (90 seconds), and the Cooking Indicator Light should turn off at 2 minutes (120 seconds).

When set at 2'-30", the Bacon Indicator Light should flash at 2 minutes (120 seconds), and the Cooking Indicator Light should turn off at 2 minutes and 30 seconds (150 seconds).

All times are to be within +/- five (5) seconds.

6. Turn the power off.

### Checking Cycle Times (Monthly) (Mfg. No. 9300534 ONLY)

CAUTION: Grill surfaces will be hot. Care should be taken when operating this piece of equipment.

**NOTE:** A stopwatch is required for this procedure.

1. Turn the unit on and allow it to warm up for 30 minutes.
2. Ensure that the TIME 6 button is lit. If not, press and release the TIME 6 button. This button should now be lit.
3. With the stopwatch in hand, press and release the Start/Stop button and start the stopwatch.
4. Record the time when the Cooking Indicator Light turns off.
5. Repeat this test with the TIME 12 button selected.

When set at 2'-45", the Cooking Indicator Light should turn off at 2 minutes and 45 seconds (165 seconds).

When set at 2'-30", the Cooking Indicator Light should turn off at 2 minutes and 30 seconds (150 seconds).

All times are to be within +/- five (5) seconds.

6. Turn the power off.



## Checking Grill Platen Temperature

### WARNING

This procedure exposes you to hot surfaces. Use extreme care when performing procedure to avoid personal injury.

**NOTE:** A pyrometer is required for this procedure.

1. Remove the cover and the Egg Rack by lifting the whole assembly until clear of the base.
2. Turn the power on and allow 30 minutes for the unit to warm up.
3. Using a pyrometer, measure the temperature at the middle of the Platen surface (Figure 4). The temperature should be 250°F–300°F (121°C–149°C).

If temperature is within range, proceed to Step 4.

If temperature is above or below the proper calibrated range, call your Authorized Service Agency.

4. Turn the power off.
5. Reinstall cover and Egg Rack and Top Cover.



Figure 4. Grill Platen (ES-600 Shown)

# TROUBLESHOOTING

## WARNING

To avoid possible personal injury and/or damage to the unit, inspection, test and repair of electrical equipment should be performed by qualified service personnel. The unit should be unplugged when servicing.

Problem	Possible Cause	Corrective Action
Unit fails to operate and control panel lights fail to signal on.	No power/low power.	Make sure the power is on and the power cord is locked into place. Check the main circuit breakers.
	Inoperable electrical outlet.	Plug the power cord into a different outlet of same amperage rating.
	Inoperable power switch.	Contact your maintenance person or an Authorized Service Agency.
	Inoperable power cord.	
	Loose connections.	
Unit fails to heat.	Loose connections.	Contact your maintenance person or an Authorized Service Agency.
	Inoperable Platen.	
	Low voltage.	
	Inoperable Hi-Limit Thermostat.	
	Inoperable Thermocouple.	
	Inoperable Solid State Relay.	
Eggs do NOT cook properly.	Using refrigerated eggs and TIME 1 button selected.	Use TIME 2 button when using refrigerated eggs.
	Using room temperature eggs and TIME 2 button selected.	Use TIME 1 button when using room temperature eggs.
	Incorrect amount of water added to trough in cover.	Fill trough in cover with water before starting time cycle.
	Platen temperature too low or too high.	Check the Platen temperature according to the Maintenance section of this manual.
	Loose connections.	Contact your Authorized Service Agency.
	Unit/table is not level	Level the table and unit as necessary.
Eggs sticking to Platen.	Dirty Platen.	Clean Platen.
	Insufficient butter being used.	Refer to the Operating section of this manual.
Eggs sticking to Egg Rings.	Insufficient butter being used.	Refer to the Operating section of this manual.
	Dirty Egg Rings.	Clean the Egg Rings but do NOT use an abrasive scrubbing pad.
	Inoperable Egg Ring.	Replace Egg Ring.
Not signaling on "Bacon" or "Ready".	Inoperable indicator light or audio signal.	Contact your maintenance person or an Authorized Service Agency.
	Inoperable control board.	
	Loose connection.	
	Bacon Timer is disabled.	Enable Bacon Timer according to the Operation section of this manual.

## Control Board LEDs

The control Board has three on board LEDs (Figure 5) to determine the status of the unit and to assist in troubleshooting.

**Green (Diagnostic):** This LED should be off in normal operation. If any of the 5 potential faults are detected by the Control Board, this LED will repeatedly blink either 1 through 5 times with a 2-second pause in between (see the Green LED Blink Codes section below).

**Yellow (Audio):** When lit, this LED indicates that the Control Board is supplying approximately 10-15 VDC to the audio signal. The audio signal should sound with this LED is lit.

**Red (Heat):** When lit, this LED indicates that the Control Board is calling for heat by supplying VDC to terminals 3(+)4(-) of the Solid State Relay. When off, this LED indicates that the grill Platen is up to operating temperature and satisfied.

**NOTE:** During heat mode, this Red LED is very dim, so it may be difficult to verify if the Control Board is or is not calling for heat. It is recommended that you observe the small round green LED on the Solid State Relay (Figure 6) for mode and diagnostic purposes. When the green LED on the Solid State Relay is on, it means that the Control Board is calling for heat. When off, it means that the Control Board is NOT calling for heat. Typically, the VDC at the Solid State Relay will be less than 1.0 VDC when measured, but may vary because of different quality VOMs. Therefore, it is recommended that you do NOT attempt to measure the VDC at the Solid State Relay for diagnostic purposes.

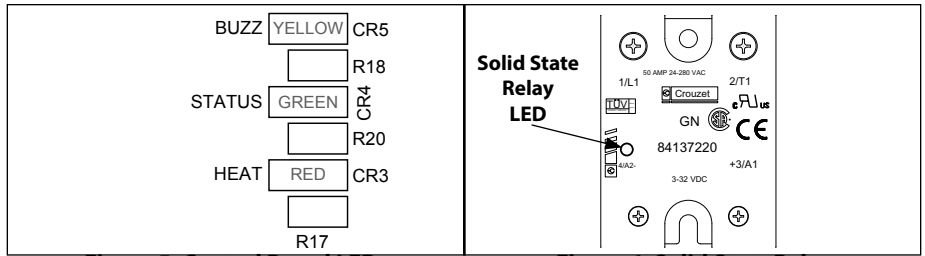

Figure 5. Control Board LEDs

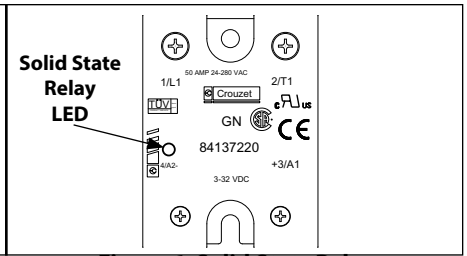

Figure 6. Solid State Relay

## Green LED Blink Codes

Number of Blinks	Cause(s)	Unit's State and Resolution
The Green LED blinks on and off 1 time, pauses for 2 seconds, and repeats.	The EEPROM memory on the Control Board is corrupted.	In this state, the unit turns off the control signal to the Solid State Relay and disables all front buttons and lights. The unit will not heat up. This continues until the defaults are reloaded into memory. To reload defaults, turn the unit off, press and hold the <b>TIME 2</b> button, turn the unit on, and release the button.
The Green LED blinks on and off 2 times, pauses for 2 seconds, and repeats.	The ambient temperature within the control compartment has exceeded 155 °F (68 °C). Verify that there is proper air ventilation all around the unit and that it is not near a significant heat source.	In this state, the unit turns off the control signal to the Solid State Relay and disables all front buttons and lights. The unit will not heat up. This continues until the ambient temperature within the electrical compartment drops below 140°F (60°C) and the unit is turned off and back on.
The Green LED blinks on and off 3 times, pauses for 2 seconds, and repeats.	Open or disconnected Thermocouple.	In this state, the unit turns off the control signal to the Solid State Relay and disables all front buttons and lights. The unit will not heat up. This continues until the Thermocouple is reconnected or replaced, and the unit is turned off and back on.
The Green LED blinks on and off 4 times, pauses for 2 seconds, and repeats.	The supply voltage to the unit is below 160 VAC or above 265 VAC.	In this state, the unit turns off the control signal to the Solid State Relay and disables all front buttons and lights. The unit will not heat up. This continues until the supply voltage is within the proper limits and the unit has been turned off and back on.
The Green LED blinks on and off 5 times, pauses for 2 seconds, and repeats.	The 50/60 Hz signal has been lost due to a disconnected or an open wire harness/wiring on the AC Isolator Board, or from the AC Isolator Board to the Control Board.	In this state, the unit turns off the control signal to the Solid State Relay and disables all front buttons and lights. The unit will not heat up. This continues until the 50/60 Hz signal is reapplied and the unit is turned off and back on.

# WIRING DIAGRAM

**NOTE:** ALL WIRES TO BE 14 GA. TFE-200°C  
 UNLESS OTHERWISE SPECIFIED.  
 # 18 GA. TFE-200°C  
 • 22 GA. TFE-200°C

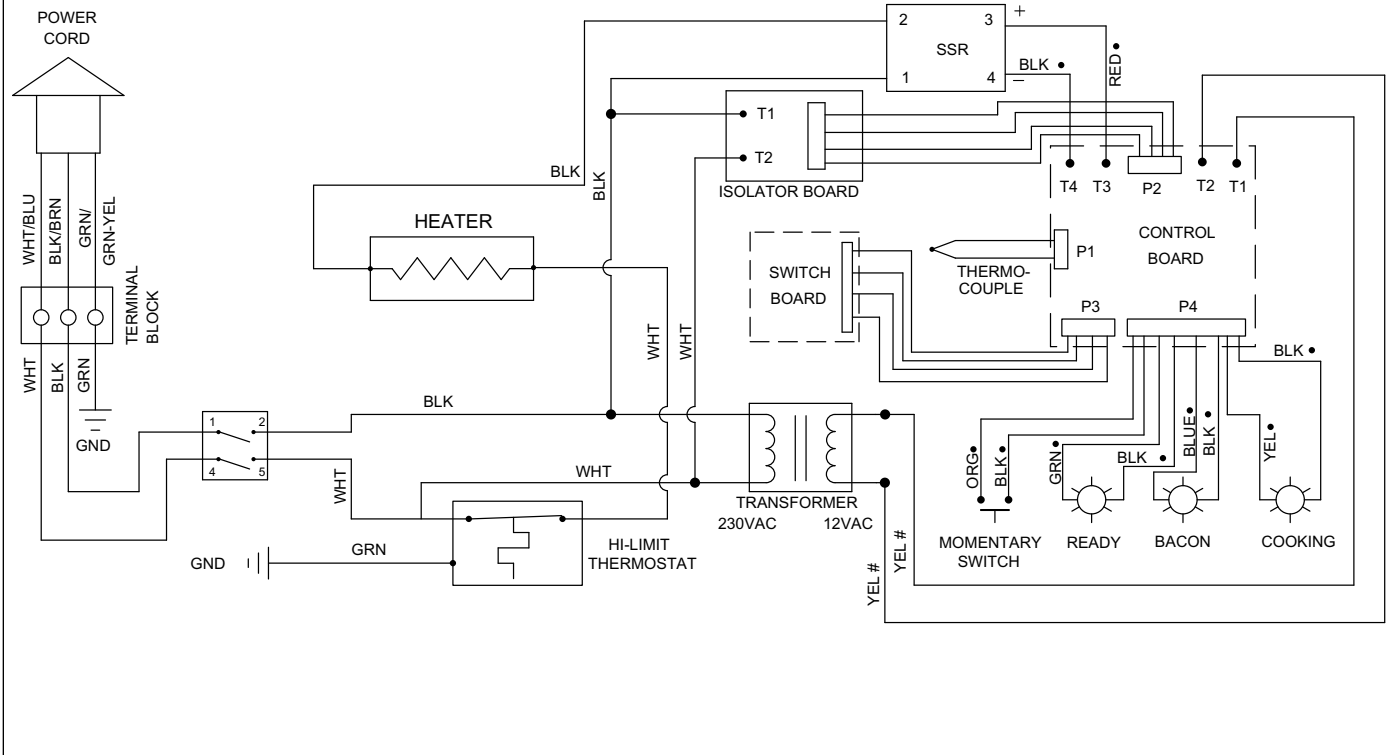

# REPLACEMENT PARTS

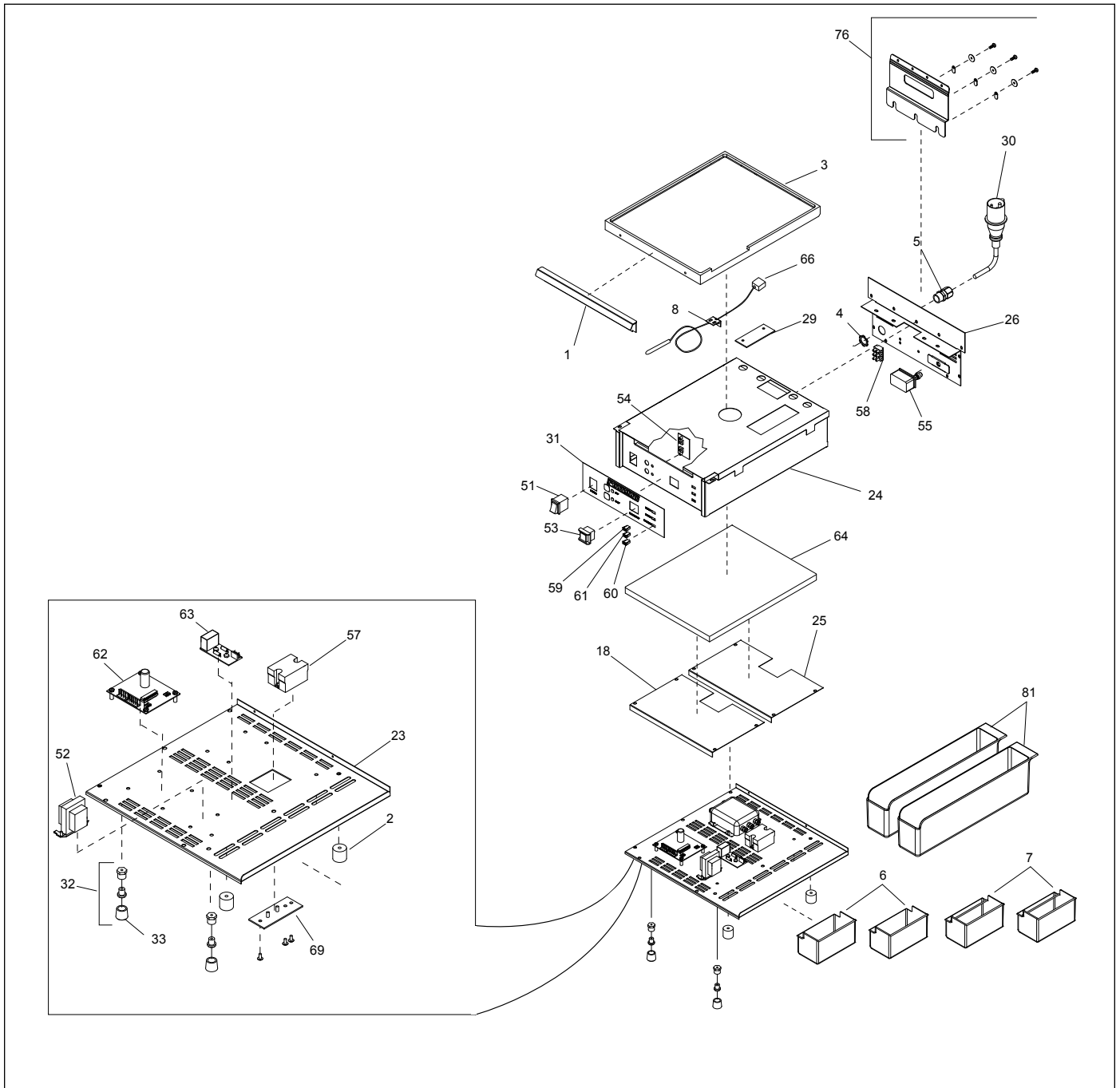

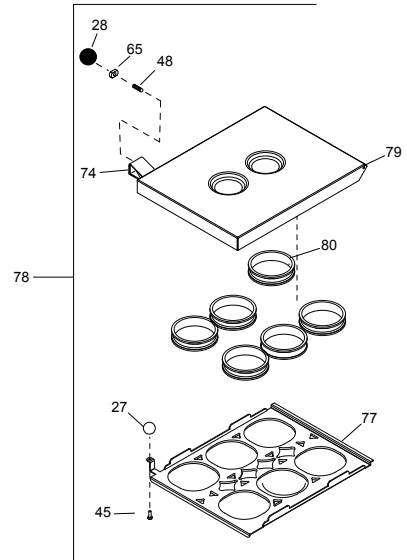
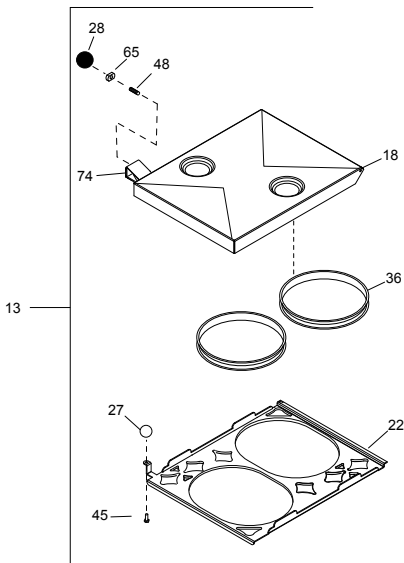
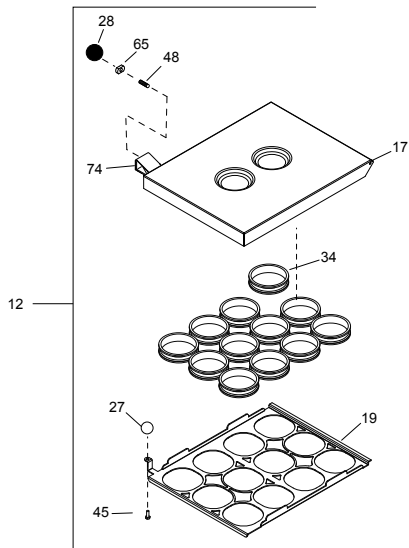
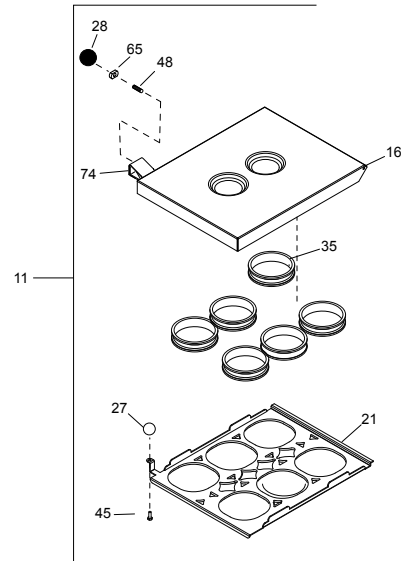
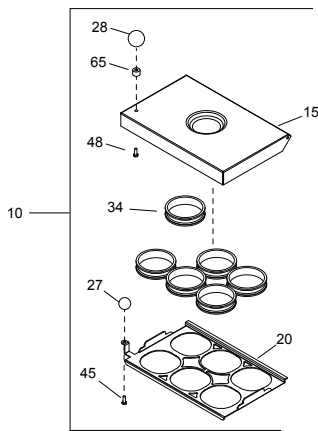
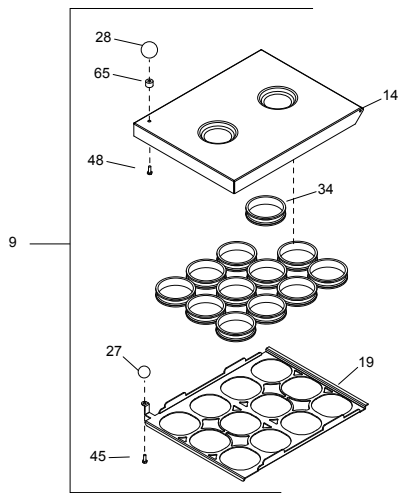

**NOTE:** Item 1 for Mfg. No. 9300132 uses a different Left Side Panel than other units contained in this manual. This allows the power cord for 9300132 to be located on the Left side of the unit rather than on the front of the unit. The new Left Side Panel part numbers is 0506673.

**Replacement Parts can be purchased from an authorized dealer. Contact  
A.J. Antunes & Co. at 1-630-754-1000 or toll free in the United States at 1-800-253-2991.**

Item	Part #	Description	Qty.
1	0021327	Nose Piece Weldment	1
2	210K230	Bumper, Recess Leg 1" (Set of 4 including 4 screws)	1
3	7000379	Grill Platen	1
	7000674	Grill Platen (Mfg. No. 9300593 Only)	1
4	040P138*	Lock-nut, Conduit - 1/2" NPT	1
5	040K251	Strain Relief Kit	1
6	2180270	Service Pan (For Mfg. No. 9300530 & 532)	2
7	2180277	Service Pan (For. Mfg. No. 9300534, 574, & 575)	2
8	0502900	Bracket, Sensor	1
9	7000363	Cover, Rack & Ring Assembly (Incl. All Shown) ES-1200	1
10	7000261	Cover, Rack & Ring Assembly (Incl. All Shown) ES-600	1
11	7000835	Cover, Rack & Ring Assembly (Incl. All Shown (ES-604) (except Mfg. No. 9300593)	1
12	7000690	Cover, Rack & Ring Assembly (Incl. All Shown) (For Mfg. No. 9300534 only)	1
13	7000635	Cover, Rack & Ring Assembly (Incl. All Shown) ES-602	1
14	7000541	Cover, 12 Egg (Incl. #28, 48, & 65) ES-1200	1
15	7000453	Cover, 6 Egg (Incl. #28, 48, & 65) ES-600	1
16	7000836	Cover, 4" Egg Rings (Incl. #28, 48, & 65) ES-604 (except Mfg. No. 9300593)	1
17	0012204	Cover, 12 Egg (Incl. #28, 48, 65, & 74)	1
18	7000639	Cover, 8" Oval Ring ES-602 (Incl. #28, 48, 65, & 74)	1
19	7000452	Rack, 12 Egg Ring (Incl. #27 & 45) ES-1200	1
20	7000454	Rack, 6 Egg Ring (Incl. #27 & 45) ES-600	1
21	7000837	Rack, 4" Egg Rings (Incl. #27 & 45) ES-604 (except Mfg. No. 9300593)	1
22	7000640	Rack, 8" Egg Rings (Incl #27 & 45) ES-602	1
23	0021324	Panel, Base	1
24	0021325	Housing, Main	1
25	0504075	Cover, Insulation	2
26	0021326	Rear Panel Weldment	1

Item	Part #	Description	Qty.
27	2100137	Knob Ball	1
28	2100138	Knob Ball	1
29	0504078	Bracket, Hi-Limit	1
30	0700323	Power Cord Assembly 6-20P	1
	0700453	Power Cord CEE 7/7 Mfg. No. 9300623 Only	1
31	1001100	Label, Control	1
31a	1001248	Label, Control (not shown) (For Mfg. No. 9300534 Only)	1
31b	1001425	Label, Control (not shown) (Mfg. No. 9300593 only)	1
31c	1002664	Label, Control (not shown) (Mg. No. 9300621 only)	1
32	210K122	Adj. Leg Kit (Pack of 4)	1
33	210K108	Rubber Tip Kit (Pack of 4)	1
34	2130111	Egg Ring (Single) ES-600/1200	6/12
	213K101	Egg Ring (Pack of 6) ES-600/1200	1/2
35	2130176	4" Egg Ring (single) ES-604 (except Mfg. No. 9300593)	6
	213P179	4" Egg Ring (Pack of 6) ES-604 (except Mfg. No. 9300593)	1
36	2130183	8" Round Egg Ring (Single) ES-602	1
	213P183	8" Round Egg Ring (Pack of 2) ES-602	1
37	306P113*	Screw, Mach. #6-32 x 7/8" Sltrshd	1
38	306P123*	Screw, Mach. #6-32 x 5/8" Sltrshd	1
39	306P130*	Nut, Hex KEPS #6-32	1
40	308P102	Washer, Int. Tooth #8	1
41	308P104*	Scr, Mach. #8-32 x 3/8" Sltrshd	1
42	308P143*	Nut, Hex KEPS #8-32	1
43	308P157*	Screw, Tap #8-32 x 3/8"	1
44	310P102*	Washer, Int Tooth Lock #10	1
45	310P09*	Scr, Mach #10-32 x 3/8" Sltrshd	1
46	310P136*	Scr, Mach. #10-32 x 1 1/4" Slpanhd	1
47	310P149*	Scr, Mach #10-32 x 7/8" Slpanhd	1
48	325P101*	Stud, 1/4-20 x 1-1/2"	1
49	325P104*	Washer, Flat 1/4" S/S	1
50	325P109*	Scr, HXCAP 1/4-20 x 3/4"	1
51	4010137	Switch, Rocker (25A-250V)	1
52	4010187	Transformer, Stepdown (240V/12)	1

Item	Part #	Description	Qty.
53	4010190	Switch, Momentary	1
54	4010193	PC-Board, Switch-Two Button	1
55	7000272	Thermostat, Hi-Limit	1
57	7000370	Solid State Relay	1
58	7000137	Terminal Block, 3-pole	1
59	4060362	LED, Snap-in (Green - Ready)	1
60	4060363	LED, Snap-in (Yellow - Cooking)	1
61	4060385	LED, Snap-in (Blue - Bacon)	1
62	7000520	Control Board	1
62a	7000691	Control Board Kit (For Mfg. No. 9300534 only)	1
62b	7001129	Control Board Kit (For Mfg. No. 9300621 only)	1
63	7000391	A/C Line Isolator Board	1
64	0400337	Insulation	1
65	2120111	Spacer	1
66	4050214	Thermocouple	1
67	2180111	Plastic Dispensing Bottle (Not shown)	1
68	213K115	Spatula, Scraper, and Brush Kit (Not Shown)	1
69	0011251	Heat Sink Assembly	1
70	0700648	Wire Set, Main (Not Shown)	1
71	0700655	Wire Harness/PCB-LEDs (Not Shown)	1
72	0700656	Wire Harness/PCB-Isolator BD (Not Shown)	1
73	0700657	Wire Harness/PCB-2 Button BD (Not Shown)	1
74	0021401	Handle Weldment	1
75	300P102*	Nut, Speed #8-32 "U"	1
76	7000838	Back Bracket Assembly Kit (All ES-604 units except Mfg. No. 9300593).	1
77	7001020	Egg Rack Assembly Kit 3.75" Rings (Mfg. No. 9300593 Only)	1
78	7001021	Egg Rack & Cover Kit - 3.75" Rings (Mfg. No. 9300593 Only)	1
79	7000836	Cover & Hinge Kit (Mfg. No. 9300593 Only)	1
80	213P188*	Egg Ring 3.75" Pkg of Six (Mfg. No. 9300593 Only)	1
81	2180259	Scrap Tray (For Mfg. No. 9300593 Only)	2

\*Available in packages of 10 (ten)

## LIMITED WARRANTY

Equipment manufactured by Roundup Food Equipment Division of A.J. Antunes & Co. has been constructed of the finest materials available and manufactured to high quality standards. These units are warranted to be free from electrical and mechanical defects for a period of one (1) year from date of purchase under normal use and service, and when installed in accordance with manufacturer's recommendations. To insure continued operation of the units, follow the maintenance procedures outlined in the Owner's Manual. During the first 12 months, electro-mechanical parts, non-overtime labor, and travel expenses up to 2 hours (100 miles/160 km), round trip from the nearest Authorized Service Center are covered.

1. This warranty does not cover cost of installation, defects caused by improper storage or handling prior to placing of the Equipment. This warranty does not cover overtime charges or work done by unauthorized service agencies or personnel. This warranty does not cover normal maintenance, calibration, or regular adjustments as specified in operating and maintenance instructions of this manual, and/or labor involved in moving adjacent objects to gain access to the equipment. This warranty does not cover consumable/wear items. This warranty does not cover damage to the Load Cell or Load Cell Assembly due to abuse, misuse, dropping of unit/shock loads or exceeding maximum weight capacity (4 lbs). This warranty does not cover water contamination problems such as foreign material in water lines or inside solenoid valves. It does not cover water pressure problems or failures resulting from improper/incorrect voltage supply. This warranty does not cover Travel Time & Mileage in excess of 2 hours (100 miles/160 km) round trip from the nearest authorized service agency.
2. Roundup reserves the right to make changes in design or add any improvements on any product. The right is always reserved to modify equipment because of factors beyond our control and government regulations. Changes to update equipment do not constitute a warranty charge.
3. If shipment is damaged in transit, the purchaser should make a claim directly upon the carrier. Careful inspection should be made of the shipment as soon as it arrives and visible damage should be noted upon the carrier's receipt. Damage should be reported to the carrier. This damage is not covered under this warranty.
4. Warranty charges do not include freight or foreign, excise, municipal or other sales or use taxes. All such freight and taxes are the responsibility of the purchaser.
5. This warranty is exclusive and is in lieu of all other warranties, expressed or implied, including any implied warranty or merchantability or fitness for a particular purpose, each of which is hereby expressly disclaimed. The remedies described above are exclusive and in no event shall Roundup be liable for special consequential or incidental damages for the breach or delay in performance of this warranty.



### U.S. Headquarters

Carol Stream, Illinois  
Phone: (630) 784-1000  
Toll Free: (800) 253-2991  
Fax: (630) 784-1650

### China Facility

Suzhou, China  
Phone: 86-512-6841-3637  
Toll Free: 86-512-6841-3907  
Fax: 400-0-7878-22