

# **GST-3V**

## **Gold Standard Toaster owner's manual**

**Manufacturing Numbers:**

9210875

## TABLE OF CONTENTS

<b>Table of Contents</b>	<b>2</b>
<b>Warranty</b>	<b>2</b>
<b>Information</b>	<b>2</b>
<b>Service/Technical Assistance</b>	<b>2</b>
<b>Important Safety Information</b>	<b>3</b>
<b>Warnings</b>	<b>3</b>
<b>Specifications</b>	<b>4</b>
<b>Shipping Weight</b>	<b>4</b>
<b>Installation</b>	<b>5</b>
<b>Operation</b>	<b>5</b>
Light/Dark Adjustments	5
<b>User Mode</b>	<b>6</b>
<b>Manager Mode</b>	<b>6</b>
<b>Safety Features</b>	<b>6</b>
Hi-Limit Control	6
Purging buns from Toaster	6
Fault Messages	6
Error Codes	6
<b>Daily Cleaning</b>	<b>7</b>
<b>Replacing Belts (Quarterly)</b>	<b>7</b>
Removing Belts	7
Installing Belts	7
Cleaning the Top Cooling Fan and Electrical Housing (Annually)	8
<b>Troubleshooting</b>	<b>9</b>
<b>Replacement Parts</b>	<b>11</b>
<b>Replacement Part Kits</b>	<b>15</b>
<b>Wiring Diagram</b>	<b>16</b>
<b>Notes</b>	<b>17</b>
<b>Limited Warranty</b>	<b>20</b>

## WARRANTY INFORMATION

Please read the full text of the Limited Warranty in this manual.

If the unit arrives damaged, contact the carrier immediately and file a damage claim with them. Save all packing materials when filing a claim. Freight damage claims are the responsibility of the purchaser and are not covered under warranty.

The warranty does not extend to:

- Damages caused in shipment or damage as result of improper use.
- Installation of electrical service.
- Normal maintenance as outlined in this manual.
- Malfunction resulting from improper maintenance.
- Damage caused by abuse or careless handling.
- Damage from moisture into electrical components.
- Damage from tampering with, removal of, or changing any preset control or safety device.

## SERVICE/TECHNICAL ASSISTANCE

If you experience any problems with the installation or operation of your unit, contact Antunes Technical Service.

Fill in the information below and have it handy when calling for assistance. The serial number is on the specification plate located on the rear of the unit.

Use only genuine Antunes replacement

\_\_\_\_\_  
Purchased From

\_\_\_\_\_  
Date of Purchase

\_\_\_\_\_  
Model Number

\_\_\_\_\_  
Serial Number

\_\_\_\_\_  
Manufacturing Number

parts in this unit. Use of replacement parts other than those supplied by the manufacturer will void the warranty.

### IMPORTANT

A.J. Antunes & Co. reserves the right to change specifications and product design without notice. Such revisions do not entitle the buyer to corresponding changes, improvements, additions or replacements for previously purchased equipment.

### IMPORTANT

Keep these instructions for future reference. If the unit changes ownership, be sure this manual accompanies the equipment.

## IMPORTANT SAFETY INFORMATION

Use the following guidelines for safe operation of the unit.

- Read all instructions before using equipment.
- For your safety, the equipment is furnished with a properly grounded cord connector. Do not attempt to defeat the grounded connector.
- Install or locate the equipment only for its intended use as described in this manual. Do not use corrosive chemicals in this equipment.
- Do not operate this equipment if it has a damaged cord or plug, if it is not working properly, or if it has been damaged or dropped.
- This equipment should be serviced by qualified personnel only. Contact your nearest Authorized Service Agency for adjustment or repair.
- Do not block or cover any openings on the unit.
- Do not immerse cord or plug in water.
- Keep cord away from heated surfaces.
- Do not allow cord to hang over edge of table or counter.
- Turn the power off, unplug the power cord, and allow unit to cool down before performing any service or maintenance on the unit.

**NOTE:** **Turning off the power switch does NOT turn off all power to the unit.**

- The procedures in this manual may include the use of chemical products. These chemical products will be highlighted with bold face letters followed by the abbreviated HCS (Hazard Communication Standard). See Hazard Communication Standard manual for the appropriated Material Safety Data Sheets (MSDS).
- The equipment should be grounded according to local electrical codes to prevent the possibility of electrical shock. It requires a grounded receptacle with separate electrical lines, protected by fuses or circuit breaker of the proper rating.
- All electrical connections must be in accordance with local electrical codes and any other applicable codes.
- Do not clean this appliance with a water jet.

## WARNINGS

Be advised of the following warnings when operating and performing maintenance on this unit.

- If the supply cord is damaged, it must be replaced by the manufacturer or its service agent or a similarly qualified person in order to avoid a hazard.
- Do not modify the power supply cord plug. If it does not fit the outlet, have a proper outlet installed by a qualified electrician.
- Do not use an extension cord with this appliance.
- Electrical ground is required on this appliance.
- Check with a qualified electrician if you are in doubt as to whether the appliance is properly grounded.
- When using a chemical cleaner, be sure it is safe to use on cast aluminum. Observe all precautions and warnings on product label.
- Inspection, testing, and repair of electrical equipment should only be performed by qualified service personnel.
- Do not use a sanitizing solution or abrasive materials. These may cause damage to the stainless steel finish.
- Chlorides or phosphates in cleaning agents (e.g. bleach, sanitizers, degreasers or detergents) could cause permanent damage to stainless steel equipment. The damage is usually in the form of discoloration, dulling of metal surface finish, pits, voids, holes, or cracks. This damage is permanent and not covered by warranty.
- The following tips will help in the maintenance of stainless steel equipment:
  - Always use soft, damp cloth for cleaning, rinse with clear water and wipe dry. When required, always rub in direction of metal polish lines.
  - Routine cleaning should be done daily with soap, ammonia detergent, and water.
  - Stains and spots should be sponged using a vinegar solution.
  - Finger marks and smears should be rubbed off using soap and water.
  - Hard water spots should be removed using a vinegar solution.

# SPECIFICATIONS

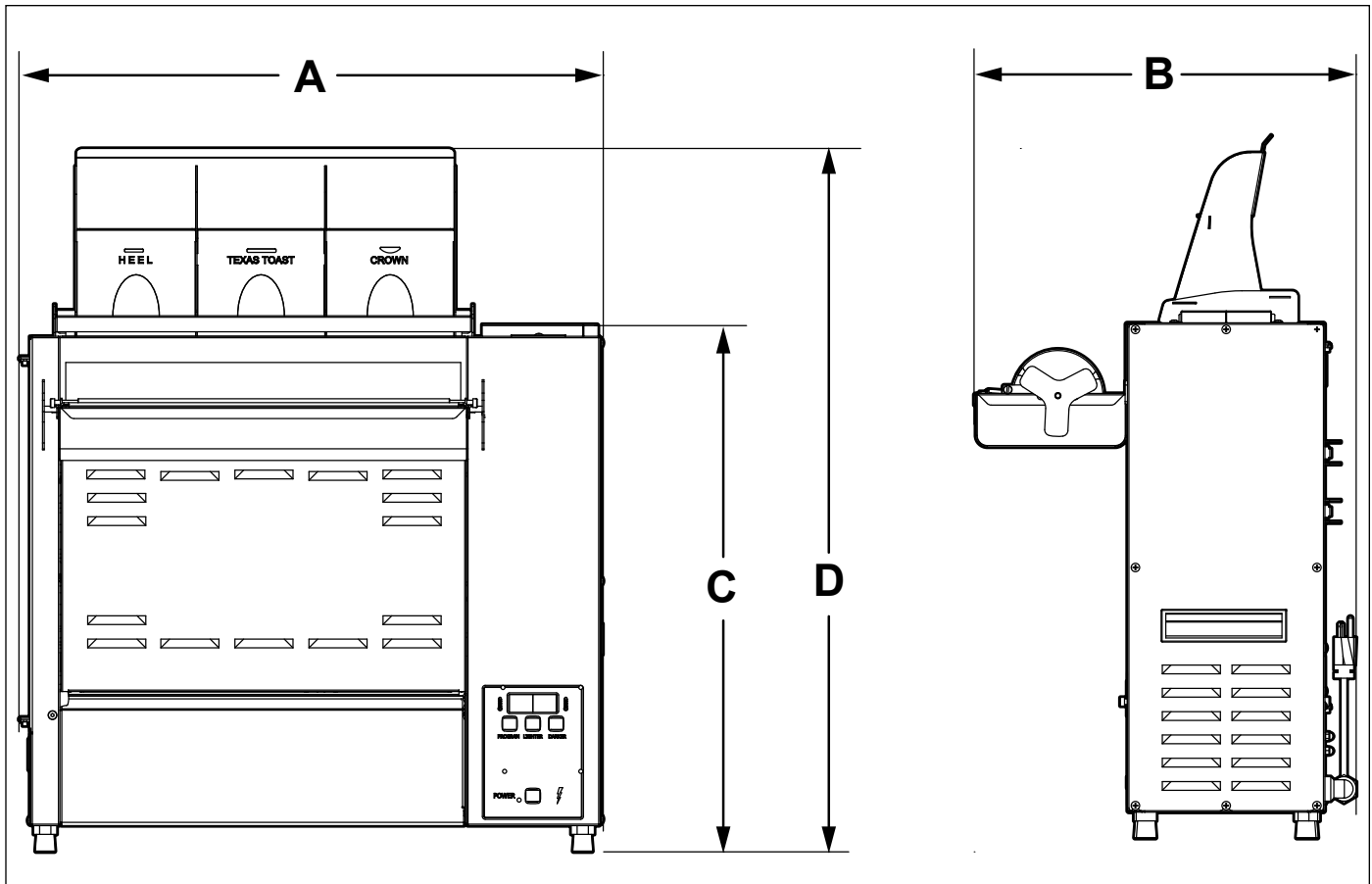

Model & Mfg. No.	Width (A)	Depth (B)	Height (C)	Height (D)
GST-3V 9210875	25" (635 mm)	16 1/2" (419 mm)	22 1/2" (572 mm) (without Bun Feeder)	30" (762 mm) (with Bun Feeder)

Model & Mfg. No.	Volts	Watts	Hertz	Plug Description
GST-3V 9210875	208/240	3300- 3840	50/60	NEMA 6-20P 20 Amp, 250 Volt Non-Locking

## SHIPPING WEIGHT

GST-3V Series 127 lbs (58 kg)

## INSTALLATION

1. Remove unit and all packing materials from shipping carton.
2. The unit is shipped with the following items:
  - Butter Wheel Assy. (including Butter Wheel and Butter Pan)
  - Bun Feeder
  - Owner's Manual

**NOTE:** If any parts are missing or damaged, contact Antunes Technical Service IMMEDIATELY at 1-877-392-7854 or 1-630-784-1000.

3. Remove all packing materials and protective coverings from the unit.
4. Wipe the entire exterior of the toaster and the accessories mentioned above with a hot damp cloth. Allow to air dry

**NOTE:** Do NOT use a dripping wet cloth. Wring out before use.

5. Attach the Bun Chute, Bun Feeder, and Butter Wheel assembly.

When placing the toaster into service, pay attention to the following guidelines.

- Make sure the power switch is off and the unit is at room temperature before plugging in the power cord.
  - Do not block or cover any openings on the unit.
  - Do not immerse the power cord or plug in water.
  - Keep the power cord away from heated surfaces.
  - Do not allow the power cord to hang over edge of table or counter.
  - Place the unit on a sturdy, level table or other work surface.
  - Turn the power switch to off (if it is set to on).
  - Ensure the line voltage corresponds to the stated voltage on the specification label and power cord warning tag.
6. Plug the power cord into the appropriate power outlet. Refer to the specification plate for the proper voltage.

## OPERATION

1. Turn the unit on and allow it to warm up until USE appears in the display
2. Drop product into the appropriate lane on the Bun Feeder according to Bun Feeder labels. Insert buns with the cut side facing away from the front of the toaster
3. Finished product drops into the bun landing zone.

### Light/Dark Adjustments

The light/dark value can be adjusted when the unit is displaying "USE". To adjust the light/dark value, press the **LIGHTER** or **DARKER** button. The display will change to show the current light/dark value.

**NOTE:** The default light/dark value is d0.

Press the **LIGHTER** or **DARKER** buttons to change the light/dark value. The adjustment range is L1-L9 and d0-d9. L9 is the lightest, d0 is the middle, and d9 is the darkest setting.

To save the light/dark value, press the **PROGRAM** button or wait 5 seconds until the screen displays "USE".

**NOTE:** Adjusting the light/dark value does NOT change the temperature. It changes the speed of the conveyors. The light/dark value will reset to the default value of d0 when the unit is turned off.

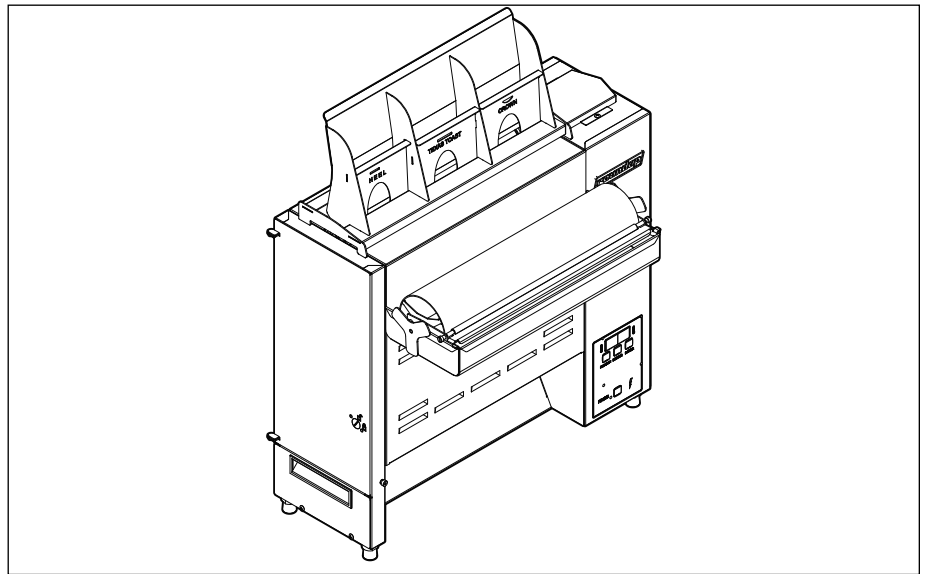

Figure 1.

## USER MODE

User Mode allows an operator to view the toaster settings but does not permit any adjustments.

1. Press and hold the **PROGRAM** button for 5 seconds. After 5 seconds, the display will show the actual temperature of the Rear Platen.
2. Press the **LIGHTER** button to toggle between the setpoint and actual temperature of the Rear Platen Heater.
3. Press the **PROGRAM** button to proceed to the Front Platen Heater menu. The display shows the actual temperature of the Front Platen.
4. Press the **LIGHTER** button to toggle between the setpoint and actual temperature of the Front Platen.
5. Press the **PROGRAM** button to proceed to the Motor Menu. The display shows the actual speed of the motor.
6. Press the **LIGHTER** button to toggle between the setpoint and actual speed of the Motor.

**NOTE:** The unit exits User Mode after 5 seconds of keypad inactivity.

## MANAGER MODE

Manager Mode allows an operator to view and adjust the following settings:

- Rear Platen Temperature
- Front Platen Temperature
- Motor Speed
- Temperature Units (°C or °F)
- Current Selection: 208 or 240 volts

Manager Mode also allows an operator to view (but not adjust) the Ambient Temperature of the Control Compartment as well as the number of days of operation.

1. Turn the unit off.
2. Turn the power on while holding the **PROGRAM** button.
3. Release the **PROGRAM** button when the unit displays "CODE."
4. Enter the appropriate code and press the **PROGRAM** button.
5. To adjust the Platen Setpoint Temperature, press the **LIGHTER** or **DARKER** buttons to reach the desired temperature.

**NOTE:** The recommended temperature setting for the Rear Platen is 535° F (279° C).

6. Press **PROGRAM** to proceed to the Front Heater Setpoint Temperature.

7. To adjust the Front Heater Setpoint Temperature, press the **LIGHTER** or **DARKER** buttons to reach the desired temperature.

**NOTE:** The recommended temperature setting for the front Platen is 515° F (268° C).

8. Press the **PROGRAM** button to proceed to the Motor Speed Setpoint.
9. Adjust the Motor Speed Setpoint by pressing the **LIGHTER** or **DARKER** buttons to reach the desired speed.

**NOTE:** The Motor Speed is adjustable from 1-100. The recommended setting is 50.

10. Press the **PROGRAM** button to proceed to the Temperature Units.
11. To change the Temperatures units from Fahrenheit or Celsius, press the **LIGHTER** or **DARKER** buttons.
12. Press the **PROGRAM** button to proceed to the Ambient Temperature of the Control Compartment.

**NOTE:** No changes can be made to the Ambient Temperature of the Control Compartment. Temperatures under 150° F (66° C) are acceptable.

13. Press and hold the **PROGRAM** button to save any changes.

**NOTE:** The unit exits Manager Mode after 30 seconds of keypad inactivity.

## SAFETY FEATURES

### Hi-Limit Control

A Hi-Limit Control turns off electrical power to the heaters and control circuits if the unit overheats. To reset the control:

1. Allow 10 - 15 minutes for the unit to cool.
2. Locate the two Hi-Limit Controls on the rear of the unit. Remove the two black protective caps.
3. Press and release both buttons. Reinstall the protective caps.

**NOTE:** If the Hi-Limit Controls require continuous resetting, contact your Authorized Service Agency.

### Purging buns from Toaster

If buns get stuck in the toaster, press and hold both the **UP** and **DOWN** arrow buttons to increase the belt speed until the buns are purged from the toaster.

## Fault Messages

The unit displays fault messages when there is a problem with the unit.

- "Hi" flashes if the Rear Platen Heater temperature is 30° F more than the setpoint or if the Rear Platen Thermocouple is disconnected or open.
- "CHEC" flashes when the control compartment ambient temperature is more than 150° F (66° C). All heaters shut off. The unit will not restart until the control compartment ambient temperature falls below 140° F (60° C).
- "PO" flashes if the incoming power drops below 190 volts. The toaster shuts down.
- "StoP" flashes when the motor has stopped for seven continuous seconds.
- "SpEd" flashes when the motor speed drops 25% below the Setpoint for 30 continuous seconds.

## Error Codes

If any of the following Error Codes appear, turn the power off, allow the unit to cool, and turn the power back on. Call your Authorized Service Agency if errors repeat.

**NOTE:** ERR #1, 2, 3, 5, 6, 7, and 30 to 51: Internal Error. Cycle the power. If error persists, replace the board.

Error	Description
ERR 4	Invalid DIP Switch setting. The only approved setting is (left to right) up-down-up-up.
ERR 8	Motor running when it should be off.
ERR 9	High Internal Temperature.
ERR 10	Shorted Rear Thermocouple.
ERR 11	Open Rear Thermocouple.
ERR 12	Shorted Front Thermocouple.
ERR 13	Open Front Thermocouple.
rPLt ERR 14	Slow warm-up, rear Platen.
FPLt ERR 15	Slow warm-up, front Platen.
F-HL ERR 16	Front Hi-limit Thermostat.
r-HL ERR 17	Rear Hi-Limit Thermostat.
rSSr ERR 18	Rear Solid State Relay.
FSSr ERR 19	Front Solid State Relay.
StoP ERR 20	The Motor is stopped.

## DAILY CLEANING

1. Turn the toaster's power switch to the off position. The toaster enters a 45 minute cool-down mode and automatically shuts down when complete.

**NOTE:** Be sure to perform cleaning steps during cool-down mode.

2. Put on neoprene gloves and remove the Bun Feeder and the Butter Wheel.
3. Clean the outside surfaces of the toaster with a paper towel sprayed with an approved multi-surface cleaner. Allow to air dry.
4. Wipe the Bun Feeder Assembly with a paper towel sprayed with an approved multi-surface cleaner. Allow to air dry.
5. Wash, rinse, and sanitize the Bun Wheel assembly at the sink and allow to air dry.
6. Remove the Front and Rear Conveyor Covers by lifting up and away from the unit.

**NOTE:** Replace all Belts if any of the Belts are discolored, torn, or if any of the Belt Snaps are damaged.

**NOTE:** Only clean the rear Belt when it is in front of the Backing Plate. This avoids causing damage to the Belt. The conveyors continue to turn during the cool-down period.

7. Inspect the front and rear Belts. Replace all of the belts if any of them are torn, folded, discolored, missing snaps, or damaged in any way.
8. If the Belts are all in good condition, spray a clean, sanitized towel with an approved sanitizer. Press and hold both arrow buttons for 5 seconds. PUR appears on the display with a blinking cursor. This locks the belt speed in Purge mode for 5 minutes to assist in cleaning. Wipe the front and rear Belts clean. Allow to air dry.
9. Press any button to exit Purge mode.

**NOTE:** Only clean the Belt where it is in front of the Backing Plate. This avoids causing damage to the Belt.

10. Clean the Front and Rear Conveyor Covers with a paper towel sprayed with an approved multi surface Cleaner. Allow to air dry.

11. Reinstall the Front and Rear Conveyor Covers and then re-install the Bun Feeder and Butter Wheel assemblies.
12. Re-fill the Butter Wheel pan.
13. Turn the toaster on and test the unit before returning it to operation.

**NOTE:** These cleaning steps may need to be repeated to remove heavy carbon buildup.

**NOTE:** Be sure to clean and sanitize the Belts completely. Failure to properly clean the Belts will shorten the life of the Belts and result in poor toaster performance.

**NOTE:** Replace all Belts if any of the Belts are discolored, torn, or if any of the Belt Snaps are damaged. To obtain new Belts, contact the factory at 1-877-392-7854 (North America only) or 630-784-1000.

**NOTE:** Belts should be removed ONLY during Belt replacement or when required in a service situation.

## REPLACING BELTS (QUARTERLY)

Over time, the Belts begin to show signs of wear. This wear appears in the form of tears or discoloration of the belt, at which point all belts should be replaced.

**NOTE:** Belts should be removed ONLY during Belt Replacement or when required in a service situation. For proper operation, re-place all belts at the same time.

### Removing Belts

1. Turn the toaster off's power switch to the off position. The toaster enters a cool-down mode and will automatically shut down when complete.
2. Unplug the power cord once the cool-down period is complete.
3. Put on neoprene gloves. Remove the Bun Feeder.
4. Remove the Front and Rear Conveyor Covers by lifting up and away from the toaster.
5. Set the Compression Knob from 4 to 7.
6. Unlock the latch and open the left side panel.

7. To lock out the front Conveyor Roller, face the front of the toaster. Use both hands and push down on the Front Conveyor Roller and pull towards you. This removes tension and locks the roller in place.
8. To lock out the Rear Roller, face the rear of the toaster. Use both hands and push down on the Rear Conveyor Roller and push away from you. This removes tension and locks the roller in place.
9. Lift the upper Belt Frame Lock. Then rotate down so it rests on the cam shaft of the rear conveyor roller.
10. Pull down the lower Belt Frame Lock.
11. Using a utility knife, cut the existing Front Belts and remove from the toaster. Discard the old Belts.
12. Using a utility knife, cut the Rear Belt and remove from the toaster. Discard the old Belt.

### Installing Belts

**NOTE:** To obtain new Belts, contact the factory at 1-877-392-7854 (North America only) or 630-784-1000.

1. Follow the steps for Removing Belts.
2. Wipe both sides of the new Belts with a clean, sanitized towel sprayed with an approved sanitizer and allow to air dry.
3. Slide the new rear belt gently over the rear top roller and rear bottom roller.

**NOTE:** Make sure the belt lines up properly on the rollers. The snaps on the belts should face the inside of the top front roller.

4. Slide the Heel/Texas Toaster belt over the front bottom roller. Repeat this step for the crown belt.

**NOTE:** Make sure the belt lines up properly on the rollers. The snaps on the belts should face the inside of the top rear roller. Belts must be installed so the exposed diagonal seam of the belt is away from the direction of belt travel.

5. Return the Front and Rear Belt Rollers to full tension by sliding them toward each other so each roller locks into place.
6. Slowly lift up the Lower Belt Frame Lock so the Front and Rear Belt Rollers lock into place.

7. Re-engage the Upper Belt Frame Lock by lifting up and then locking it in place on the Front Conveyor Assembly.
8. Close and latch the Side Panel.

**NOTE:** Inform the Store Manager after any Belt Replacement so new Belts can be ordered. To obtain new Belts, contact the factory at 1-877-392-7854 (North America only) or 630-784-1000.

9. Set the Compression Knob from 7 to 4.
10. Re-install the Front and Rear Conveyor Covers and then the Bun Feeder Assembly.
11. Plug in the toaster and test the unit before returning to service.

### **Cleaning the Top Cooling Fan and Electrical Housing (Annually)**

Follow these steps to clean the top fan.

12. Turn the power switch to the OFF position. The toaster enters a cool-down mode and will automatically shut down when complete.
13. Unplug the power cord.
14. Facing the front of the toaster, move to the right Side Panel. Remove the right Side Panel and set aside. Do not lose the screws.
15. Remove the Fan Duct cover from the top of the unit and set aside. Do not lose the screws.
16. Use a plastic brush or similar tool to brush all 5 fan blades from above and below. Be sure to remove all debris.
17. Carefully clean any debris from the inside floor of the control compartment and from all electrical connections. Be sure to remove any grease, lint, or debris from these areas.
18. Reattach the right Side Panel and Fan Duct cover securely with screws.



# TROUBLESHOOTING

Problem	Possible Cause	Corrective Action
Control Display flashes <b>FPLt</b> continuously. Buns not toasting properly.	Front Platen temperature is below 515° F (268° C).	Allow the unit to warm up for 30 minutes and then recheck. If the Control Display still flashes <b>FPLt</b> , contact your maintenance person or Authorized Service Agency for service.
	Failed front Platen Thermocouple.	Contact your maintenance person or Authorized Service Agency for service.
	Failed Control Board	
Control Display flashes <b>rPLt</b> continuously. Buns not toasting properly.	Rear Platen temperature is below 535° F (279° C).	Allow the unit to warm up for 30 minutes and then recheck. If the Control Display still reads <b>rPLt</b> , contact your maintenance person or Authorized Service Agency for service.
	Failed Rear Platen Thermocouple.	Contact your maintenance person or Authorized Service Agency for service.
	Failed Control Board.	
Control Display flashes <b>Er 9</b> continuously.	Control Compartment ambient temperature is above 150° F (66° C)	Verify side vents on toaster are unblocked and not near other heating appliances. If problem persists, contact your maintenance person or Authorized Service Agency for service.
	Failed Cooling Fan.	
	Failed Control Board	
Control Display Flashes <b>FSSr</b> continuously. Buns Burn.	Failed Front Platen Solid State Relay.	Contact your maintenance person or Authorized Service Agency for service.
	Failed Control Board.	
	Failed Front Platen Thermocouple.	
Control Display flashes <b>rSSr</b> continuously. Buns Burn.	Failed Rear Platen Solid State Relay.	Contact your maintenance person or Authorized Service Agency for service.
	Failed Control Board.	
	Failed Rear Platen Thermocouple.	
Control Display flashes <b>Er 13</b> continuously. Buns not toasting properly.	Loose Front Platen Thermocouple connection on Control Board or the Front Platen Thermocouple is open.	Re-secure the Front Platen Thermocouple to the Control Board. If the Control Display still reads <b>Er 13</b> , check the front Thermocouple for continuity. Contact your maintenance person or Authorized Service Agency for service.
	Failed Control Board.	
Control Display flashes <b>Er 11</b> continuously. Buns not toasting properly.	Loose Rear Platen Thermocouple connection on Control Board or the Rear Platen thermocouple is open.	Re-secure the Rear Platen Thermocouple connection to the Control Board. If the Control Display still reads <b>Er 11</b> , check the Rear Thermocouple for continuity. Contact your maintenance person or Authorized Service Agency for service.
	Failed Control Board.	
Control Display flashes <b>Er 12</b> continuously. Buns not toasting properly.	Shorted Front Platen Thermocouple to ground.	Disconnect and re-secure the Rear Platen Thermocouple connection to the Control Board. If the Control Display still reads <b>Er 12</b> , check the Rear Thermocouple for continuity. Contact your maintenance person or Authorized Service Agency for service.
	Failed Control Board	
Control Display Flashes <b>Er 10</b> continuously. Buns not toasting.	Shorted Rear Platen Thermocouple to ground.	Re-secure the Rear Platen Thermocouple connection to the Control Board. If the Control Display still reads <b>Er 10</b> , check the Rear Thermocouple for continuity. Contact your maintenance person or Authorized Service Agency for service.
	Failed Control Board.	
Control Display flashes <b>StoP</b> .	Mechanical bind in one or both conveyors.	Enter "user mode" to check the motor speed. Check both conveyors for mechanical binds. Test the motor. Replace necessary parts. Contact your maintenance person or Authorized Service Agency for service.
	Worn or damaged Ball Bearings.	
	Drive chain or sprockets damaged.	
	Failed Motor.	
	Failed Control Board.	
Control Display flashes <b>SpEd</b> .	Mechanical bind in one or both conveyors.	Enter "user mode" to check motor speed. Check both conveyors for mechanical binds. Replace necessary parts. Contact your maintenance person or Authorized Service Agency for service.
	Worn or damaged Ball Bearings.	
	Conveyor chains loose or damaged.	
	Drive chain or sprockets damaged.	
Crowns and/or Heels must be forced into the toaster. Buns sticking and burning.	Silicone Belts not cleaned properly.	Clean Silicone Belts as described in the Maintenance section of this manual.
	Silicone Belts are not tack/sticky to the touch (replace every 2-4 months).	Clean Silicone belts. If the Silicone Belts are too worn, replace them as described in the Maintenance section of this manual.
	Silicone Belts are dirty, worn, or damaged (replace every 2-4 months).	Clean or replace Silicone Belts as described in the Maintenance section of this manual.
	Buns do not meet specifications.	Contact your bun supplier.

## TROUBLESHOOTING (continued)

Problem	Possible Cause	Corrective Action
Buns not toasting adequately.	Compression Setting is incorrect.	Use the recommended setting of 4.
	One of the Conveyor top shafts is stuck in the lower lock position.	Inspect positions of the shafts as described in the Maintenance section of this manual.
	Either both Upper/Lower Conveyor locks are not properly locked in place.	Inspect the proper position of the locks as described in the Maintenance section of this manual.
	Buns do not meet specifications.	Contact your bun supplier.
	Motor settings are incorrect.	Verify that the motor setting is set to 4000 as described in the Programming section of this Manual.
Compression side door will not close.	Either both Upper/Lower Conveyor Locks are not properly locked in place.	Inspect the proper position of the locks as described in the Maintenance section of this manual.
	The lock on the Compression Side Door is in the locked position when trying to close the door.	Turn the lock to the unlocked position before closing the door.
Fan is making an unusual sound.	Failed Cooling Fan.	Verify vents on toaster are unblocked and not near other heating appliances. Clean fans as described in the Maintenance section of this manual. If problem persists, contact your maintenance person or Authorized Service Agency for service.
	Cooling Fan is dirty and needs to be cleaned.	
Control Display flashes <b>F-HL</b> continuously. Buns are not toasting properly.	Front Hi-Limit Control is tripped.	Allow the unit to cool and reset the Front Hi-Limit Control. If it trips again, contact your maintenance person or Authorized Service Agency for service.
Control Display flashes <b>r-HL</b> continuously. Buns are not toasting properly.	Rear Hi-Limit Control is tripped.	Allow the unit to cool and reset the Rear Hi-Limit Control. If it trips again, contact your maintenance person or Authorized Service Agency for service.
Control Display is blank.	Power Cord is not plugged in.	Plug the Power Cord into the appropriate outlet. Turn the toaster on. If the Control Display is still blank, contact your maintenance person or Authorized Service Agency for service.
	Circuit Breakers turned off or tripped. Damaged electrical outlet, plug, or Power Cord. Power Switch damaged.	Reset Circuit Breakers. If they trip again, check the Power Cord, Plug, and outlet for damage. Contact your maintenance person, Authorized Service Agency, and Electrician for service.
	Faulty Transformer.	Replace Transformer.
Conveyors not turning.	Damaged or missing Roller Tensioner(s)	Adjust or replace the Roller Tensioner(s).
	Conveyor Belt is stretched. Chain is skipping on shaft.	Measure and adjust the Conveyor Belt Chain as described in the Maintenance section of this manual.
	Motor Drive Chain is detached from sprockets.	Reinstall the Drive Chain.
	Drive Chain needs lubrication.	Lubricate Drive Chain with Lubit-8 (P/N 2140152).
	Failed Drive Motor.	Contact your maintenance person or Authorized Service Agency for service.

## REPLACEMENT PARTS (continued)

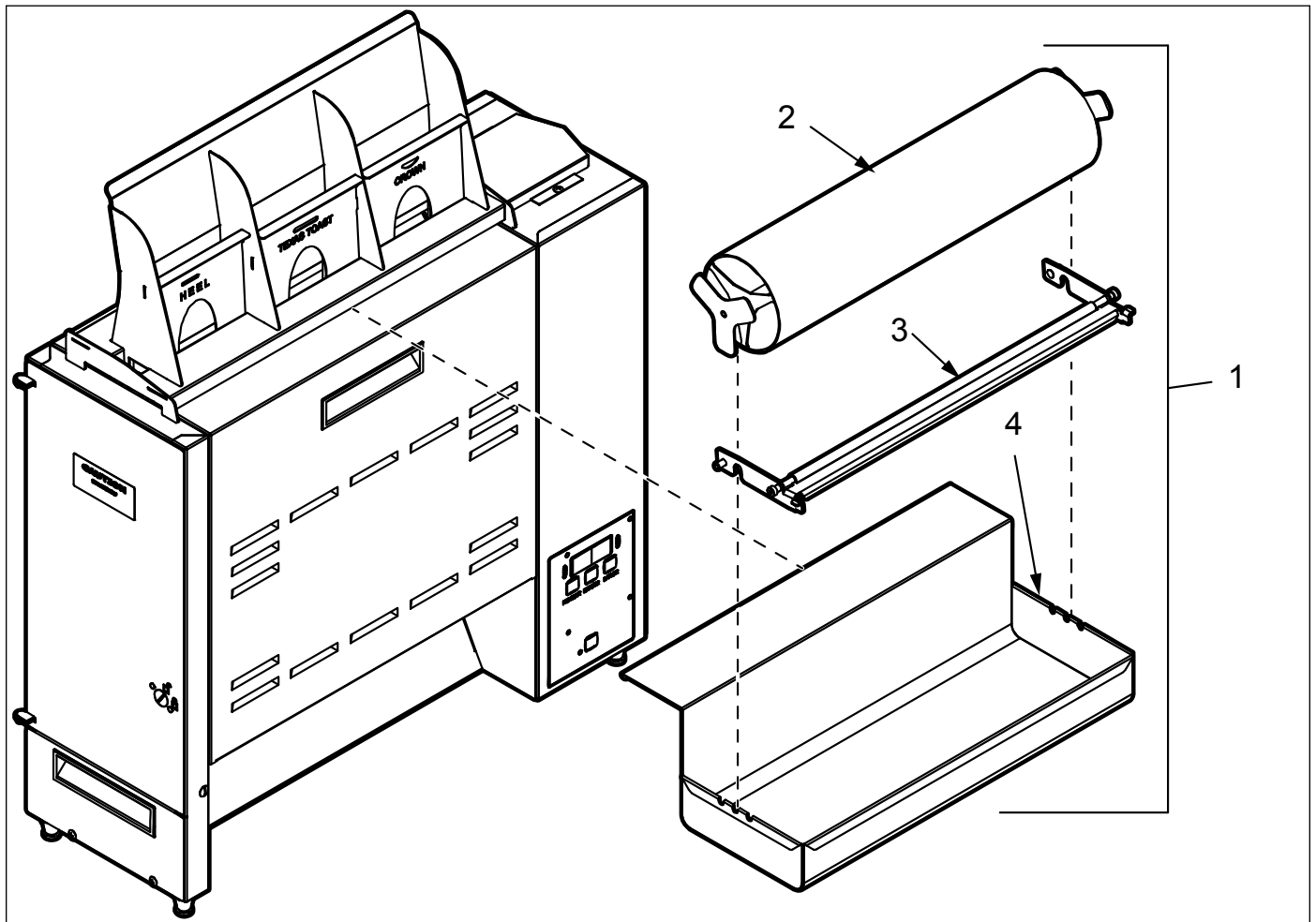

Item	Part #	Description	QTY.
1	0012891	Butter Wheel Assembly (Incl Items 2, 3, and 4)	1
2	0021850	Butter Wheel Weldment	1
3	0012890	Scraper Assembly	1
4	0506496	Butter Tray	1

## REPLACEMENT PARTS (continued)

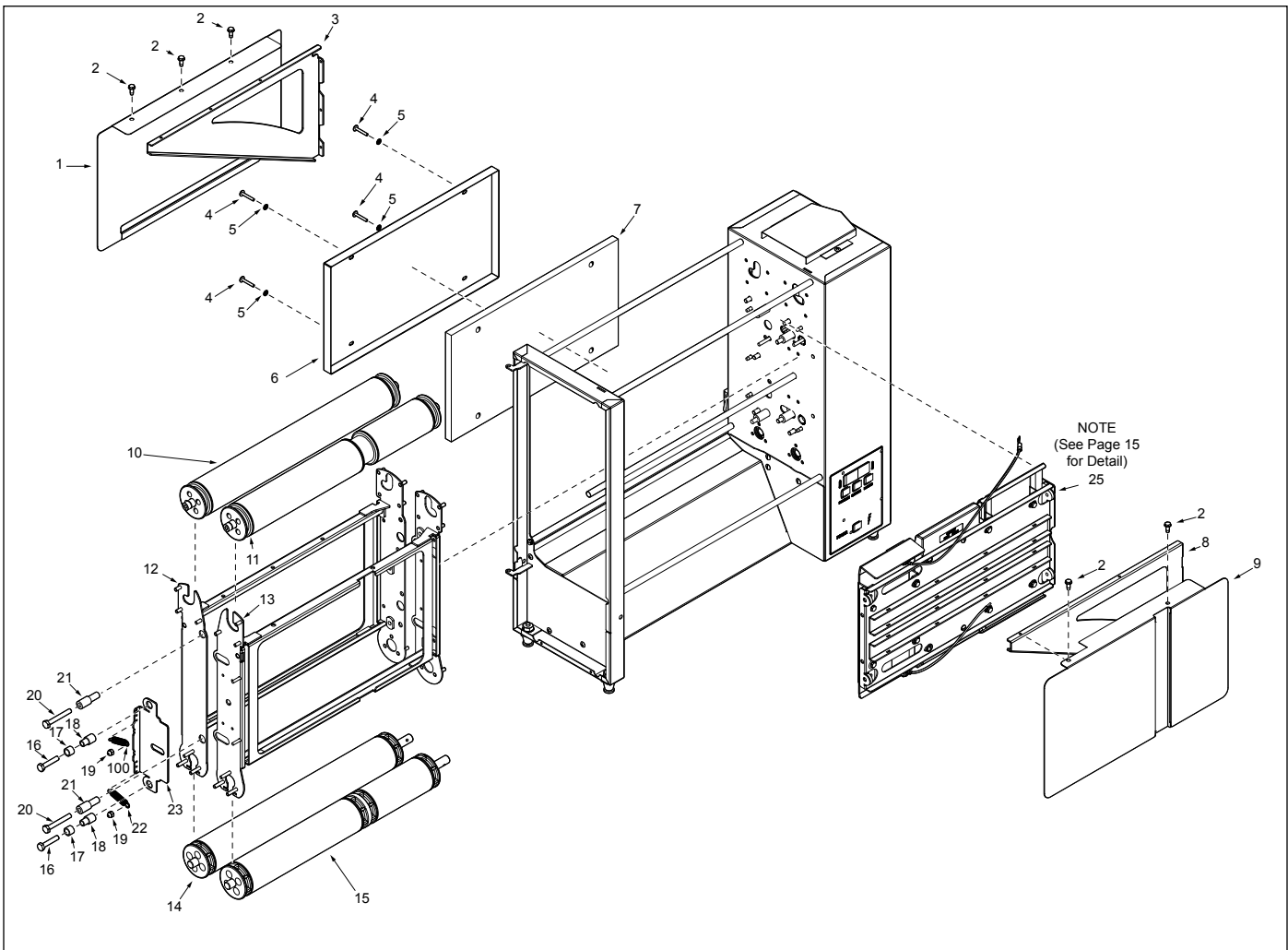

Item	Part #	Description	QTY.
1	0506514	Cover, Fixed Platen	1
2	310P214	Screw, Hex #10-32 X 1/2"	1
3	0506525	Support Bracket, RH	1
4	308P164	Scr, Mach #8-32 X 1" Lg Sltrshd S/S	1
5	308P102	Washer, Int. Tooth #8	1
6	0506524	Insulation Plate	1
7	0400427	Insulation, Main Platen	1
8	0600156	Spring, Cam Adjustment	2
9	0500650	Cover, Adj. Platen	1
10	0021839	Weldment, Idler Main Platen	1
11	0021840	Weldment, Idler Adjust Platen	1
12	0021853	Weldment, Fixed Platen Frame	1
13	0021855	Weldment, Adj. Platen Frame	1
14	0021838	Weldment, Drive Roller Main Platen	1

Item	Part #	Description	QTY.
15	0021837	Weldment, Drive Roller Adjust Platen	1
16	325P193	Screw, Hex Head, #1/4-20 X 1.375", S.S.	1
17	2120224	Sleeve Bearing, .50" Od X .375" LG	2
18	2120214	Spacer, Adjustable Frame RH	2
19	308P145	Nut, Hex Acorn #08-32 S/S T304	1
20	325P194	Screw, Hex Head, #1/4-20 X 2.00", S.S.	1
21	2120313	Spacer, Frame & Platen LH	2
22	0600143	Spring, Compression Setting	1
23	0506511	Cam Bracket, LH	1
24	310P187	Screw Set, #10-32 X 3/8 Hex Socket-Cone Point	1
25	0012888	Club Platen Sub Assembly	1
		See Page 15	

# REPLACEMENT PARTS (continued)

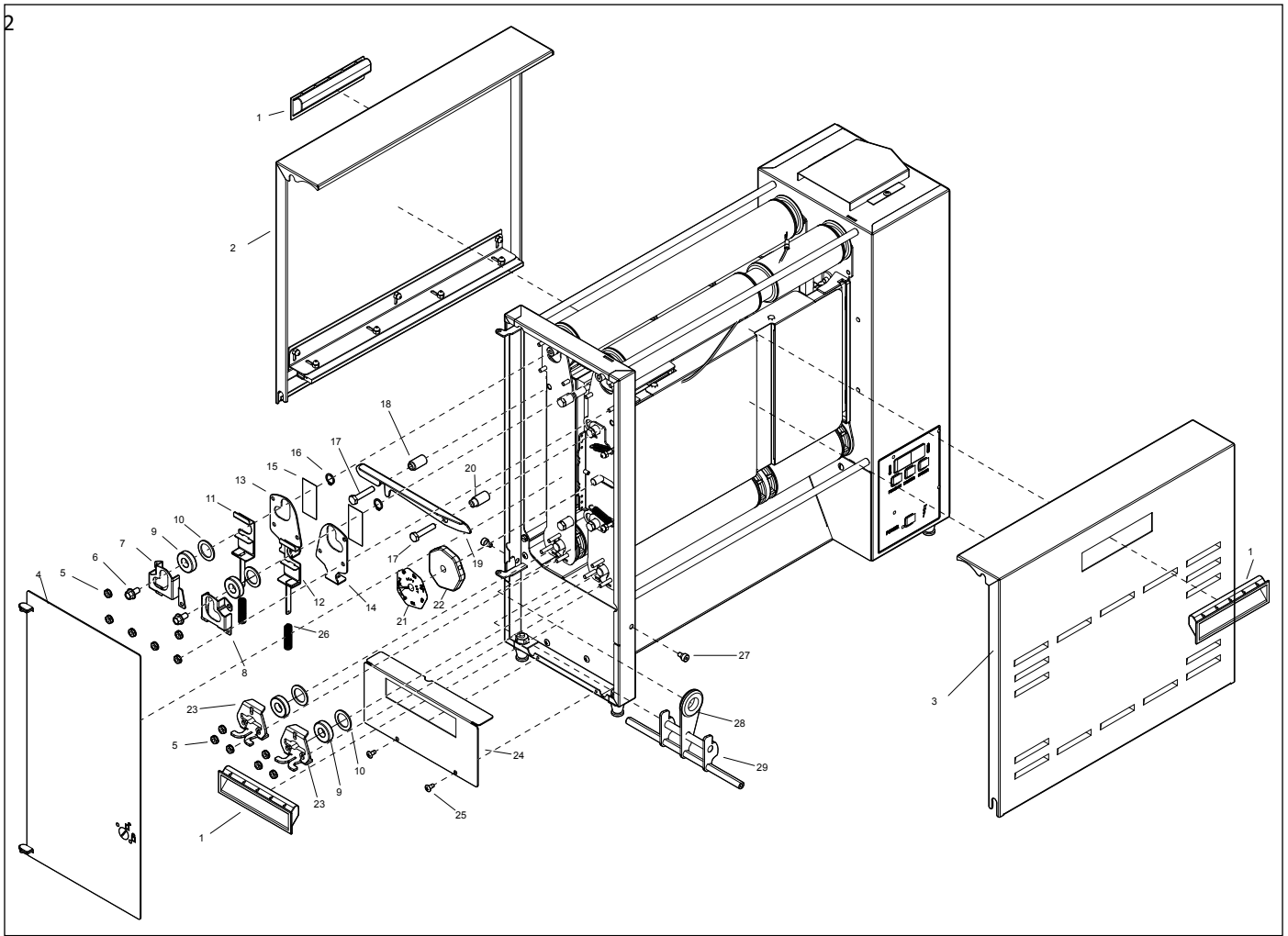

Item	Part #	Description	QTY.
1	2100212	Handle, Pocket Pull, Snap-In	4
2	0506492	Back Conveyor Cover	1
3	0506518	Front Conveyor Cover	1
4	0506519	End Housing Door	1
5	310P146	Nut, Hex 'Keps' #10-32	1
6	325P176	Screw, Flange Hex Head Cap	1
7	0506291	Bracket, Tensioner-End Housing, Rear	1
9	2150285	Bearing, Single Groove S/S	8
10	0504320	Spacer 0.781 X 1.125 X 0.06"	8
11	0506161	Bracket, Bearing LH	2
12	0506165	Clip, Bearing	4
13	0506531	Plate, Tensioner RH	1
14	0506530	Plate, Tensioner LH	1

Item	Part #	Description	QTY.
15	2100334	Thrust Strip	4
16	3000123	Ring, Retaining, External	4
17	325P193	Screw, Hex Head, #1/4-20 X 1.375", S.S.	1
18	2120217	Spacer, Upper Locking Plate RH	1
19	0506527	Bracket, Housing Locking	1
20	2120216	Spacer, Upper Locking Plate, Front	1
21	1001502	Label, Cam LH	1
22	2150347	Cam	1
23	0506167	Bracket, Bearing	2
24	0506174	End Cvr Bottom	1
25	308P157	Screw, Tap 8-32 X 3/8" LG	1
26	0600141	Spring, Compression	4
27	3100196	Screw, Shoulder 10-32 SS	2
28	0400418	Push In Grommet For 1-1/8" Dia. Hole	1
29	0021884	Screw, Mach. #6-32 X 1/4"	1

# REPLACEMENT PARTS (continued)

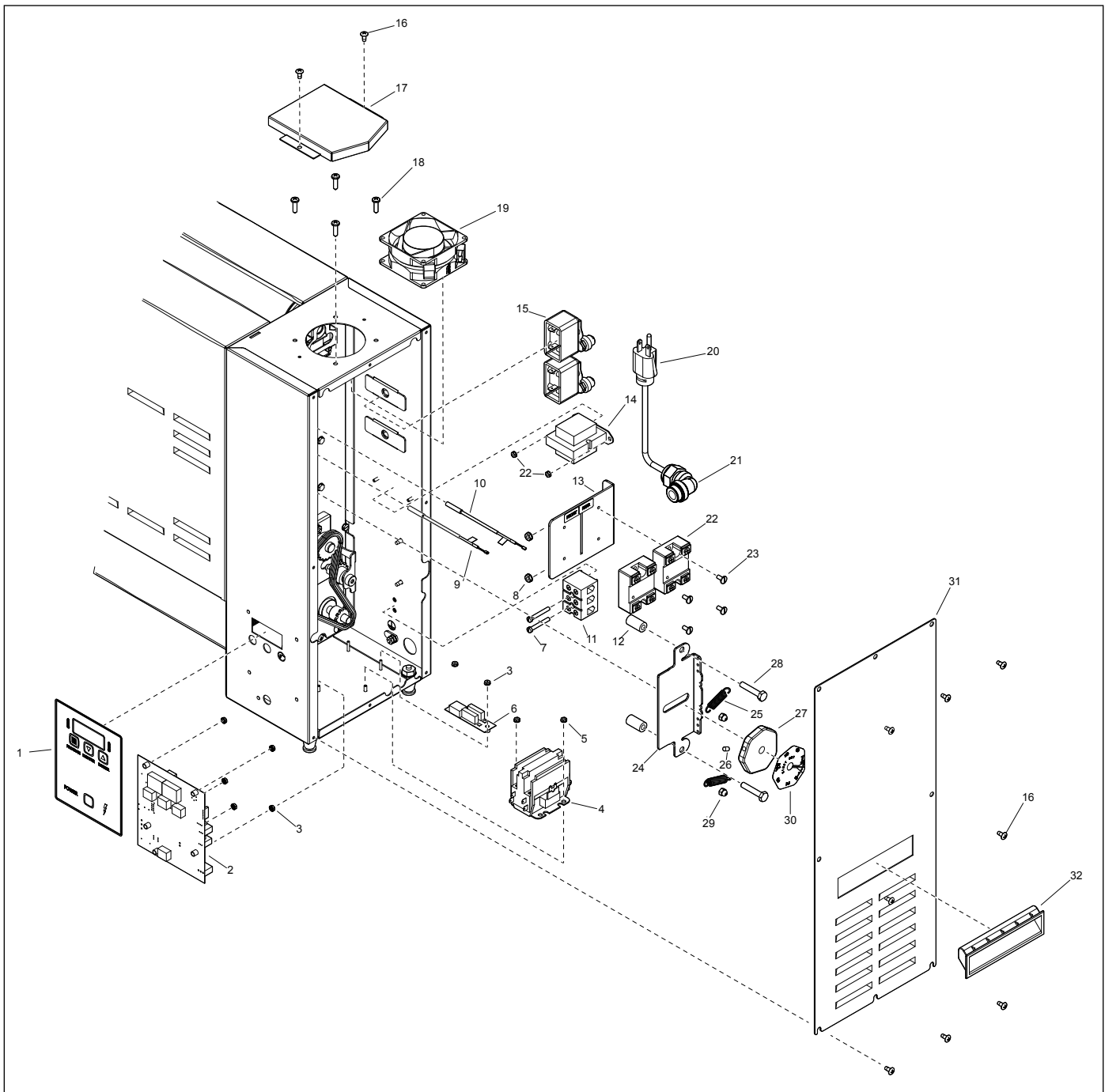

Item	Part #	Description	Qty.
1	1001505	Label, Control	1
2	7000965	Control Board Kit	1
3	304P105	Nut, Hex 'Keps' #4-40 (Pkg. Of 10)	1
4	4050236	Contactor, 2 Pole No	1
5	306P130	Nut, Hex Keps #6-32 (Small Pattern) (Pkg. Of 10)	1
6	4070154	Varistor Board	1
7	308P193	Scr, Mach #8-32 X 1 1/4" Sltfthd (Pkg. Of 10)	1
8	308P143	Nut, Hex 'Keps' #8-32 (Pkg. Of 10)	1
9	4051018	Thermocouple Type "K" (Open End), 80" Lg	1
10	4050214	Thermocouple Type "K" (Open End), 80" Lg	1

Item	Part #	Description	Qty.
11	4060398	Terminal Block, S-Series	1
12	2120233	Spacer .252 Id X .5 Od X .925" Lg	4
13	0503359	Bracket, Relay	1
14	4010187	Transformer, 240 Vac/12Vac	1
15	4030352	Thermostat, Hi-Limit 700°F	1
16	308P157	Screw, Tap 8-32 X 3/8" Lg (Pkg. Of 10)	1
17	0506477	Fan Bracket	1
18	310P213	Screw, Phpnhd #10-16 X 3/4" Thrd Form (Pkg. Of 10)	1
19	4000202	Fan, Axial - 230V, Metal Housing & Imp	1
20	0700737	Power Cord 20A, 250V Right Angle	1
21	0400354	90° Strain Relief Elbow	1
22	4051010	Relay, Random Phase, Solid State-50A	2
23	308P115	Screw, Mach. #8-32 X 3/8" (Pkg. Of 10)	1

Item	Part #	Description	Qty.
24	2100345	Thrust Strip Rh Cam	1
25	0600156	Spring, Cam Adjustment	2
26	310P187	Screw Set, #10-32 X 3/8 Hex Socket-Cone Point (Pkg. Of 10)	1
27	2150347	Cam	2
28	3250193	Screw, Hex Head, #1/4-20 X 1.375", S.S. (Pkg. Of 10)	1
29	308P145	Nut, Hex Acorn #08-32 (Pkg. Of 10)	1
30	1001504	Label, Cam Rh	1
31	0506526	Housing Door	1
32	2100212	Handle, Pocket Pull, Snap-In	4

# REPLACEMENT PARTS (continued)

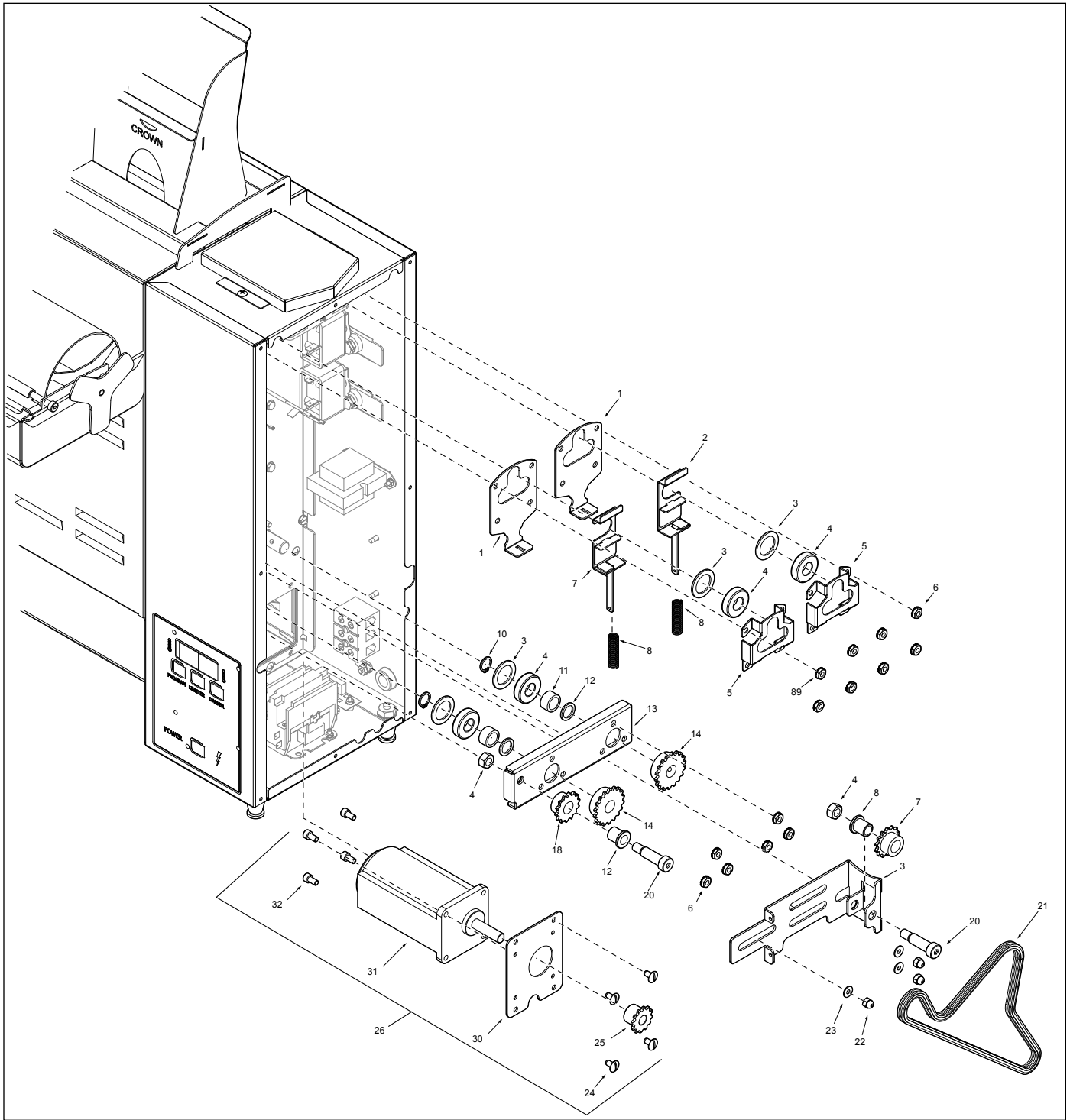

Item	Part #	Description	Qty.
1	0506144	Plate, Tensioner Rh	2
2	0506162	Bracket, Bearing Rh	2
3	0504320	Spacer 0.781 X 1.125 X 0.06"	8
4	2150285	Bearing, Single Groove S/S	8
5	0506163	Bracket, Tensioner	2
6	310P146	Nut, Hex 'Keps' #10-32	1
7	0506161	Bracket, Bearing LH	2
8	0600141	Spring, Compression	4

Item	Part #	Description	Qty.
10	3000123	Ring, Retaining, External	4
11	2120221	Spacer, 0.69 X 0.503 X 0.359	2
12	0504321	Spacer 0.503 X 0.69 X 0.06"	2
13	0506475	Retainer Idler	1
14	2150185	Sprocket, 25B18, 1/2" Bore	2
15	3310101	Nut, Hex 5/16 - 18	2
16	331P106	Lock Washer (Idler Ret)	1
17	2150313	Flanged Bearing	2

Item	Part #	Description	Qty.
18	2150312	Sprocket, 25B14, .498" Bore	2
19	0506185	Bracket, Chain Tensioner	1
20	3310103	Shoulder Bolt 3/8" X 1"	2
21	2150294	Chain Drive	1
22	308P145	Nut, Hex Acorn #08-32	1
23	304P105	Nut, Hex 'Keps' #4-40	1
24	310P104	Screw, Mach. #10-32 X 1/4"	1
25	2150316	Sprocket, 25B12 3/8" Bore	1

## REPLACEMENT PARTS (continued)

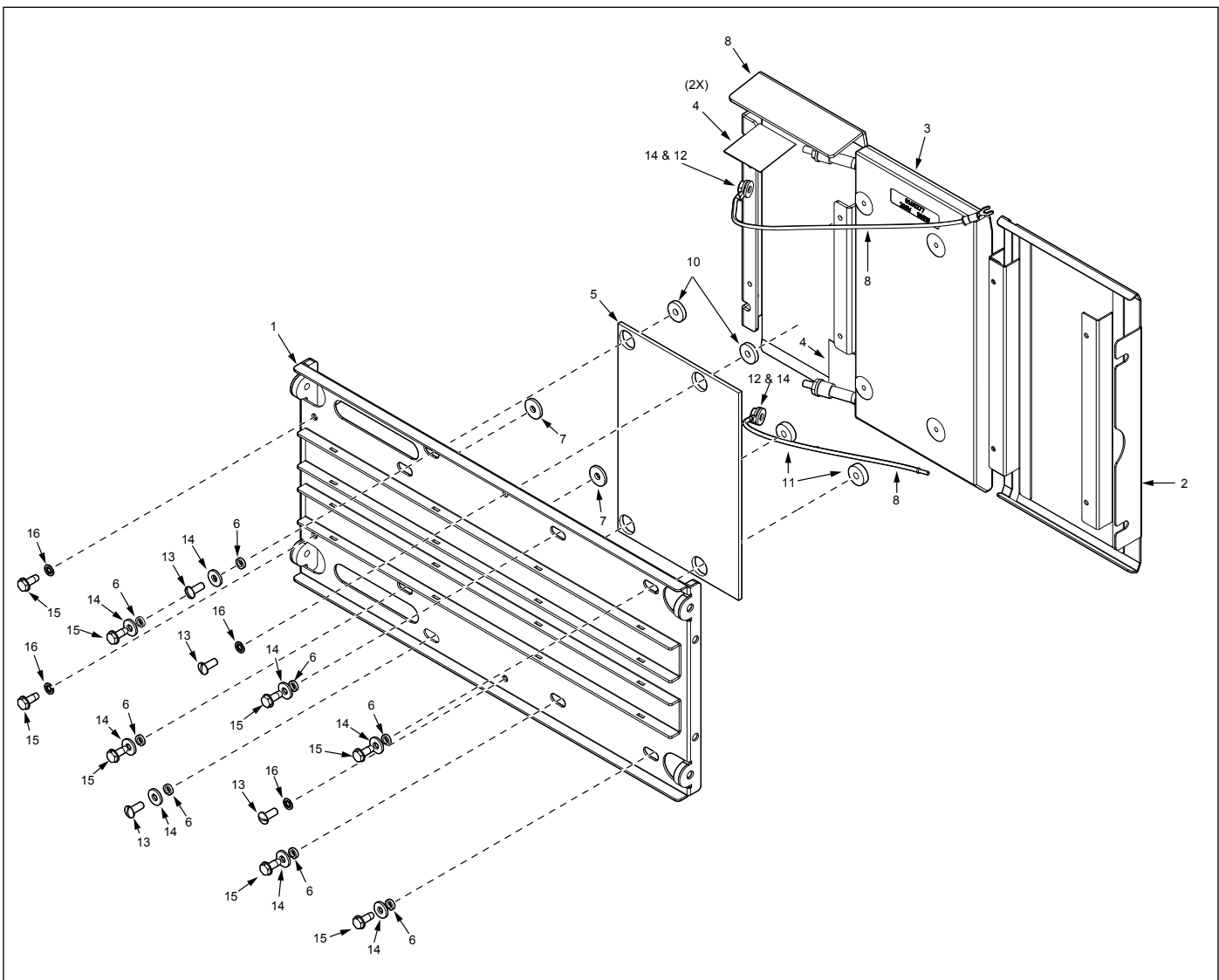

Item	Part #	Description	QTY.
1	0021815	Weldment, Back Plate Adj. Platen	1
2	0021852	Weldment, Crown Plate	1
3	0100277	Platen, Club 208V, 90W	1
4	0400290	Insulator, Electrical	2
5	310P146	Insulation, Fiber Glass, Club Platen	1

Item	Part #	Description	QTY.
6	0506083	Spacer .075 THK .203 ID x .312 OD	8
7	0506198	Spacer, .625" OD x .218" ID x .075" Thick	2
9	0506498	Plate, Heel Platen	1
10	2120236	Spacer .118 THK .204 IT X .625 OD	2
11	2120237	Spacer .185 THK .204 ID X .625 OD	2

Item	Part #	Description	QTY.
12	3100101	Hex, Nut #10-32	2
13	3100125	Screw, Mach. #10-24 x 1/2"	4
14	3100140	Washer, Flat #10	12
15	3100214	Screw, Hex #10-24 x 1/2"	8
16	3100102	Washer, Int, Tooth-lock, #10	4

## REPLACEMENT PART KITS

The following Replacement Part Kits are available for your toaster. This list may change periodically as we work towards continuous improvement.

Kit Number	Description
7000928	1/3 Belt, Crown
7000929	Full Belt, Main Belt
7000930	2/3 Belt, Heel/Club
7000954	Motor Kit
7000955	Drive Side Front Bearing and Tensioner Kit
7000956	Drive Side Rear Bearing and Tensioner Kit
7000957	Idle Side Front Bearing and Tensioner Kit
7000958	Idle Side Rear Bearing and Tensioner Kit

Kit Number	Description
7000959	Conveyor Cam Tensioner Assy (Control Side)
7000960	Conveyor Cam Tensioner Assembly Compression Side
7000961	Upper Conveyor Lock Kit
7000962	Lower Conveyor Lock Kit
7000965	Control Board Kit
7000970	Whataburger GST-3V Maintenance Kit
7000971	Squeegee Replacement Kit



# WIRING DIAGRAM

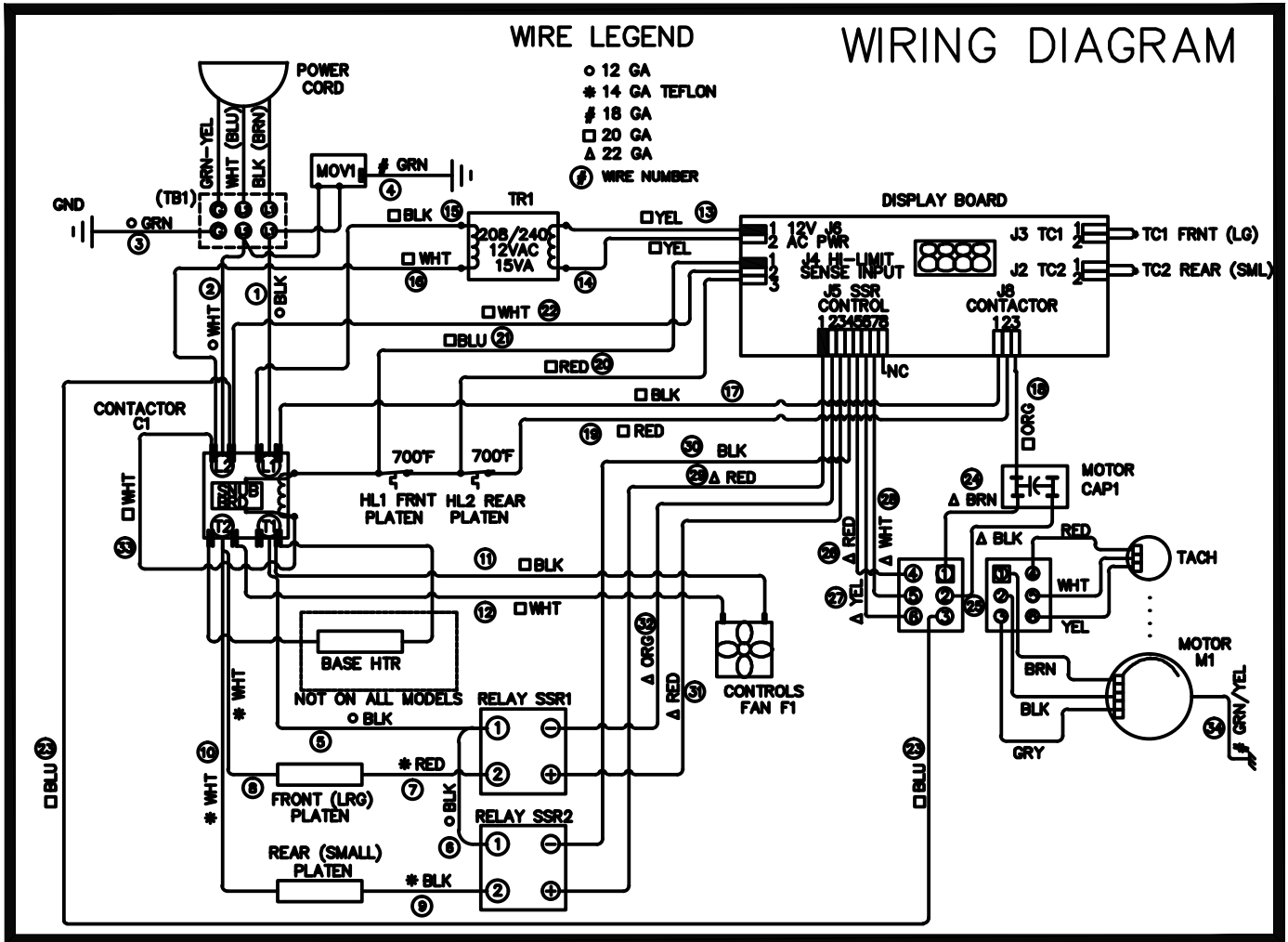





## LIMITED WARRANTY

Equipment manufactured by A.J. Antunes & Co. has been constructed of the finest materials available and manufactured to high quality standards. These units are warranted to be free from electrical and mechanical defects for a period of one (1) year from date of purchase under normal use and service, and when installed in accordance with manufacturer's recommendations. To insure continued operation of the units, follow the maintenance procedures outlined in the Owner's Manual. During the first 12 months, electromechanical parts, non-overtime labor, and travel expenses up to 2 hours (100 miles/160 km), round trip from the nearest Authorized Service Center are covered.

1. This warranty does not cover cost of installation, defects caused by improper storage or handling prior to placing of the Equipment. This warranty does not cover overtime charges or work done by unauthorized service agencies or personnel. This warranty does not cover normal maintenance, calibration, or regular adjustments as specified in operating and maintenance instructions of this manual, and/or labor involved in moving adjacent objects to gain access to the equipment. This warranty does not cover consumable/wear items. This warranty does not cover damage to the Load Cell or Load Cell Assembly due to abuse, misuse, dropping of unit/shock loads or exceeding maximum weight capacity (4 lbs). This warranty does not cover water contamination problems such as foreign material in water lines or inside solenoid valves. It does not cover water pressure problems or failures resulting from improper/incorrect voltage supply. This warranty does not cover Travel Time & Mileage in excess of 2 hours (100 miles/160 km) round trip from the nearest authorized service agency.
2. A.J. Antunes & Co. reserves the right to make changes in design or add any improvements on any product. The right is always reserved to modify equipment because of factors beyond our control and government regulations. Changes to update equipment do not constitute a warranty charge.
3. If shipment is damaged in transit, the purchaser should make a claim directly upon the carrier. Careful inspection should be made of the shipment as soon as it arrives and visible damage should be noted upon the carrier's receipt. Damage should be reported to the carrier. This damage is not covered under this warranty.
4. Warranty charges do not include freight or foreign, excise, municipal or other sales or use taxes. All such freight and taxes are the responsibility of the purchaser.
5. THIS WARRANTY IS EXCLUSIVE AND IS IN LIEU OF ALL OTHER WARRANTIES, EXPRESSED OR IMPLIED, INCLUDING ANY IMPLIED WARRANTY OR MERCHANTABILITY OR FITNESS FOR A PARTICULAR PURPOSE, EACH OF WHICH IS HEREBY EXPRESSLY DISCLAIMED. THE REMEDIES DESCRIBED ABOVE ARE EXCLUSIVE AND IN NO EVENT SHALL A.J. ANTUNES & CO. BE LIABLE FOR SPECIAL CONSEQUENTIAL OR INCIDENTAL DAMAGES FOR THE BREACH OR DELAY IN PERFORMANCE OF THIS WARRANTY.



#### Corporate Headquarters

Carol Stream, Illinois  
Phone: +1 (630) 784-1000  
Toll Free: +1 (800) 253-2991  
Fax: +1 (630) 784-1650

#### China Facility

Suzhou, China  
Phone: +86-512-6841-3637  
Toll Free: +400-0-7878-22  
Fax: +86-512-6841-3907