

# Mini Radiant Toaster

Model RT-2

**Mfg. Number**

9210906



Radiant Toaster  
EQUIPMENT

## CONTENTS

General .....	2
Warranty Information .....	2
Service/Technical Assistance.....	2
Important Safety Information .....	3
Warnings .....	3
Specifications.....	4
Installation .....	5
Operating Instructions .....	6
Toasting Product .....	6
Adjusting Toast Quality .....	7
Purging product .....	7
Factory Reset .....	7
Toaster Settings .....	8
Shutting down the Toaster .....	8
Hi Limit Reset Button .....	8
Maintenance .....	8
Daily Maintenance .....	8
Quarterly Maintenance .....	9
Error Messages.....	9
Cleaning the Fans.....	10
Adding/Removing Conveyor Belt Chain Links .....	11
Replacing the Conveyor Belt Chain.....	11
Troubleshooting .....	12
Replacement Parts.....	13
Wiring Diagram.....	18
Limited Warranty .....	20

### IMPORTANT

A.J. Antunes & Co. reserves the right to change specifications and product design without notice. Such revisions do not entitle the buyer to corresponding changes, improvements, additions or replacements for previously purchased equipment.

### IMPORTANT

Keep these instructions for future reference. If the unit changes ownership, be sure this manual accompanies the equipment.

## GENERAL

This manual provides the safety, installation, and operating procedures for your toaster. Please read all of the information contained in this manual prior to installing and operating the toaster.

Your toaster is manufactured from the finest materials available and is assembled to our strict quality standards. This toaster was tested at the factory to ensure dependable trouble-free operation.

## WARRANTY INFORMATION

Please read the full text of the Limited Warranty in this manual.

If the unit arrives damaged, contact the carrier immediately and file a damage claim with them. Save all packing materials when filing a claim. Freight damage claims are the responsibility of the purchaser and are not covered under warranty.

The warranty does not extend to:

- Damages caused in shipment or damage as result of improper use.
- Installation of electrical service.
- Normal maintenance as outlined in this manual.
- Malfunction resulting from improper maintenance.
- Damage caused by abuse or careless handling.
- Damage from moisture into electrical components.

Damage from tampering with, removal of, or changing any preset control or safety device.

## SERVICE/TECHNICAL ASSISTANCE

If you experience any problems with the installation or operation of your system, contact Antunes Technical Service at +1-877-392-7854 (toll free).

Fill in the information in the next column and have it handy when calling for assistance. The serial number is on the specification plate located on the system.

\_\_\_\_\_  
Purchased From

\_\_\_\_\_  
Date of Purchase

\_\_\_\_\_  
Model Number

\_\_\_\_\_  
Serial Number

\_\_\_\_\_  
Mfg. Number

Use only genuine Antunes replacement parts in this unit. Use of replacement parts other than those supplied by the manufacturer will void the warranty.

## IMPORTANT SAFETY INFORMATION

Use the following guidelines for safe operation of the unit.

- Read all instructions before using equipment.
- For your safety, the equipment is furnished with a properly grounded cord connector. Do not attempt to defeat the grounded connector.
- Install or locate the equipment only for its intended use as described in this manual. Do not use corrosive chemicals in this equipment.
- Do not operate this equipment if it has a damaged cord or plug, if it is not working properly, or if it has been damaged or dropped.
- This equipment should be serviced by qualified personnel only. Contact your nearest Authorized Service Agency for adjustment or repair.
- Do not block or cover any openings on the unit.
- Do not immerse cord or plug in water.
- Keep cord away from heated surfaces.
- Do not allow cord to hang over edge of table or counter.
- Turn the power off, unplug the power cord, and allow unit to cool down before performing any service or maintenance on the unit.

- The equipment should be grounded according to local electrical codes to prevent the possibility of electrical shock. It requires a grounded receptacle with separate electrical lines, protected by fuses or circuit breaker of the proper rating.
- All electrical connections must be in accordance with local electrical codes and any other applicable codes.
- Do not clean this appliance with a water jet.

## WARNINGS

Be advised of the following warnings when operating and performing maintenance on this unit.

- If the supply cord is damaged, it must be replaced by the manufacturer or its service agent or a similarly qualified person in order to avoid a hazard.
- Do not modify the power supply cord plug. If it does not fit the outlet, have a proper outlet installed by a qualified electrician.
- Do not use an extension cord with this appliance.

- Electrical ground is required on this appliance.
- Check with a qualified electrician if you are unsure if the appliance is properly grounded.
- If a chemical cleaner is used, be sure it is safe to use on cast aluminum. Observe all precautions and warnings on product label.
- Inspection, testing, and repair of electrical equipment should only be performed by qualified service personnel.
- This equipment is to be installed to comply with the basic plumbing code of the Building Officials and Code Administrators, Inc. (BOCA) and the Food Service Sanitation Manual of the Food and Drug Administration (FDA).
- Do not use abrasive materials. The use of these may cause damage to the stainless steel finish.
- Chlorides or phosphates in cleaning agents (e.g. bleach, sanitizers, degreasers or detergents) could cause permanent damage to stainless steel equipment. The damage is usually in the form of discoloration, dulling of metal surface finish, pits, voids, holes, or cracks. This damage is permanent and not covered by warranty.
- The following tips are recommended for maintenance of your stainless steel equipment:
- Always use soft, damp cloth for cleaning, rinse with clear water and wipe dry. When required, always rub in direction of metal polish lines.
- Routine cleaning should be done daily with soap, ammonia detergent, and water.
- Stains and spots should be sponged using a vinegar solution.
- Finger marks and smears should be rubbed off using soap and water.
- Hard water spots should be removed using a vinegar solution.

# SPECIFICATIONS

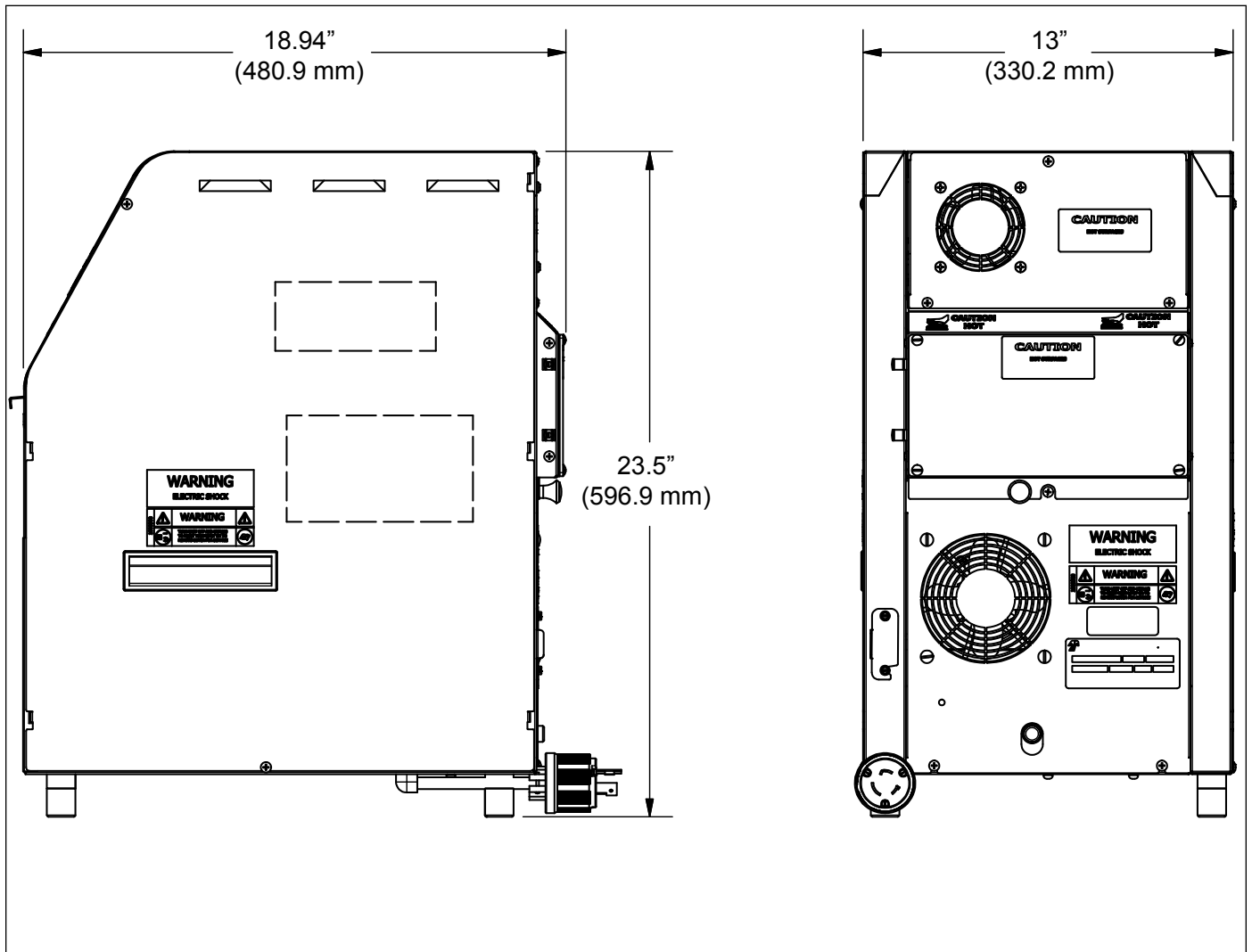

Model	Volts	Watts	Amps	Hertz	Plug Description
9210906 RT-2	208~	5000	24	50/60	L6-30P Twist Lock

## INSTALLATION

**NOTE:** When placing the toaster into service, make sure to provide at least 3 inches of space on all sides of the unit.

1. Remove unit and all packing materials from shipping carton. The toaster is shipped with the items listed below:
  - Owner's Manual
  - Authorized Service Agency Directory

**NOTE:** If any parts are missing or damaged, contact Antunes Customer Service IMMEDIATELY at +1-877-392-7856.

2. Remove all packing materials and protective coverings from the unit.
3. Refer to Figure 1. Crumb Tray and the Bun Chute. Wash these items at the 3 compartment sink and set aside to air dry
4. Wipe all surfaces of the unit with a hot damp cloth.

**NOTE:** Do NOT use a dripping wet cloth. Wring out before use.

5. Re-install the Crumb Tray and Bun Chute.

When placing the unit into service, pay attention to the following guidelines.

- Make sure to provide at least 3 inches of space on both sides of the unit and at least 6 inches from the rear of the unit and the wall.
- Make sure the power switch is off and the unit is at room temperature before plugging in the power cord.
- Do not block or cover any openings on the unit.
- Do not immerse the power cord or plug in water.
- Keep the power cord away from heated surfaces.
- Do not allow the power cord to hang over edge of table or counter.

Figure 2

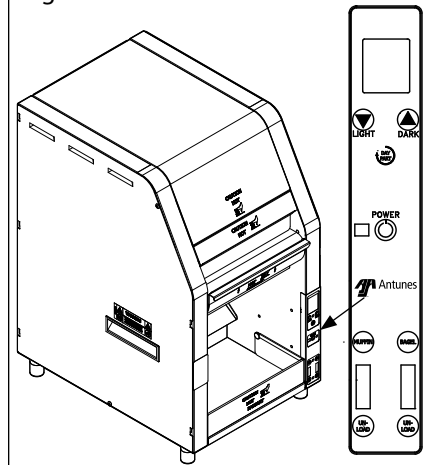

**NOTE:** The main Control Panel is located on the front of the unit.

Figure 1

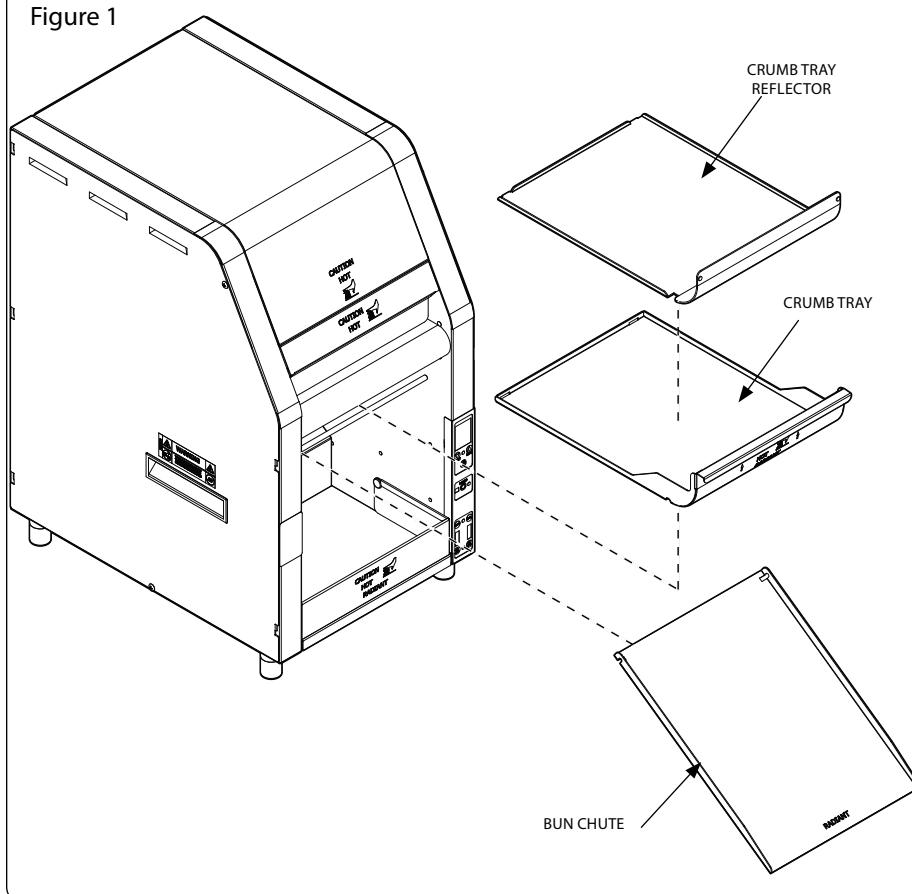

# OPERATING INSTRUCTIONS

**NOTE:** To ensure proper operation, toast some test product at the start of each day.

**NOTE:** The toaster is programmed to start up in Breakfast mode.

**NOTE:** If the toasting quality needs adjustment, refer to Adjusting Toasting Quality in the Operation section of this manual.

**1**

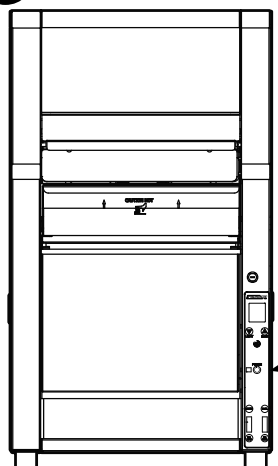

Power button. Press to turn on, press and hold to turn off.

OFF is displayed on the screen when the toaster is powered off.

**2**

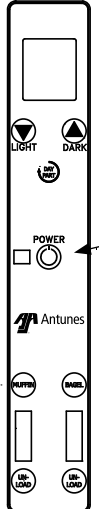

Power button.

On the front of the toaster, press the Power button to turn the toaster on. The unit makes a clicking sound. This is normal.

**3**

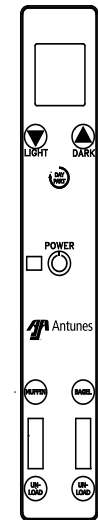

The unit displays the software version and starts to warm up (10 minutes).

**4**

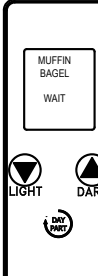

After the system check, the unit displays the Muffin Bagel Wait message. This means the unit is warming up.

**5**

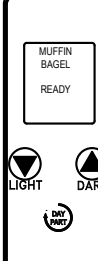

The unit displays the Muffin Bagel Ready message when it reaches proper operating temperature.

## TOASTING PRODUCT

Facing the front of the unit, insert product as described.

Insert Muffins and Bagels in the Feeder with the *cut side up*.

Refer to the image below.

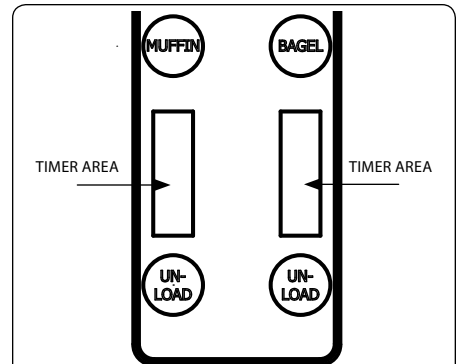
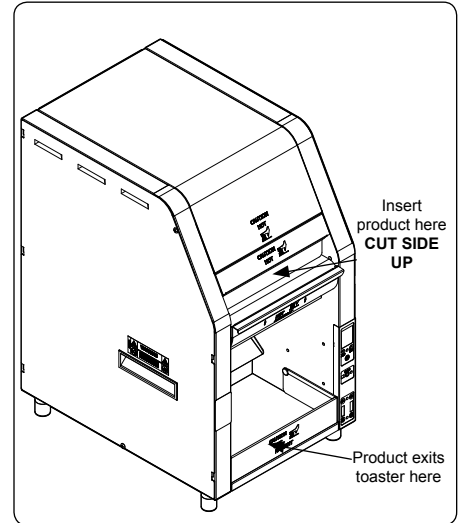

After inserting a muffin or bagel into the toaster, press the Muffin or Bagel button. This starts a timer that tracks the length of time product is held in the toaster. When you press the Muffin or Bagel button, a green light appears in the timer area (above). Each muffin or bagel toasted should be tracked. When that product is used, press the appropriate unload button to reset the timer.

- A green light in the timer means the product can be used.
- A flashing green light means the product is nearing end of usage.
- A steady red light means the product should **NOT** be used.

## ADJUSTING TOAST QUALITY

The unit can be adjusted to provide a lighter or more darkly toasted product. Follow these steps to adjust toasting quality.

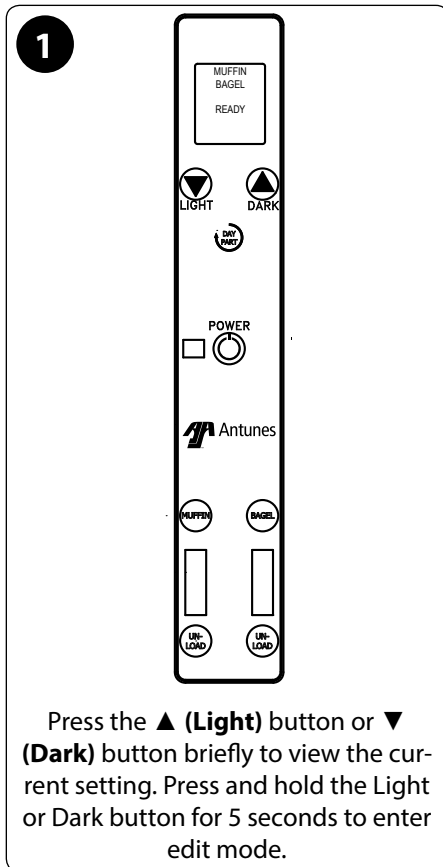

2

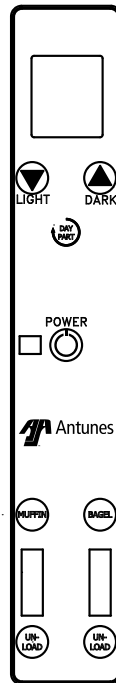

**NOTE:** The ▲ (**Light**) button decreases toasting darkness. The ▼ (**Dark**) button increases toasting darkness.

When the toaster is set as desired, release the buttons and the toaster will beep and save the settings to memory.

**NOTE:** This setting is maintained when the unit is powered off.

## PURGING PRODUCT

If you need to purge product from the toaster, press and hold both the **Light** and **Dark** buttons. The Purge message appears on the display and the toaster speeds up, purging the product.

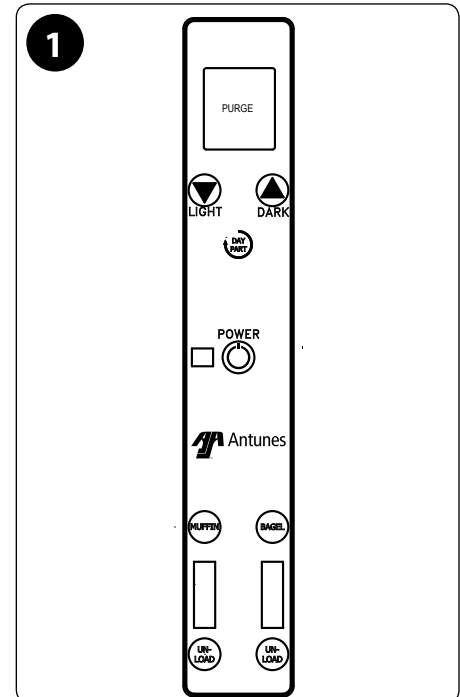

## TOASTER SETTINGS

The following tables shows the recommended settings for the toaster:

### Breakfast

Setting	Value
IR Percent Upper	80%
IR Percent Lower	70%
Air	25%
Toast Color	563

## SHUTTING DOWN THE TOASTER

Follow these steps to shut down the toaster:

1. Press and hold the Power button.
2. The unit enters cool down mode and displays **OK to Clean**. The fans continue to run. The unit shuts down completely when this cool down mode completes.

## HI LIMIT RESET BUTTON

A hi-limit control (rear of unit) turns off power to the unit if it overheats. To reset this Hi-Limit control:

1. Allow sufficient time (10-15 minutes) for the unit to cool down
2. Remove the Hi-Limit control cap at the rear of the unit.
3. Press the Hi-Limit Reset button.
4. Turn the unit on. Test the unit by toasting some test product.

If the Hi-Limit continues to trip, contact Antunes Technical Service at +1-877-392-7854 for assistance.

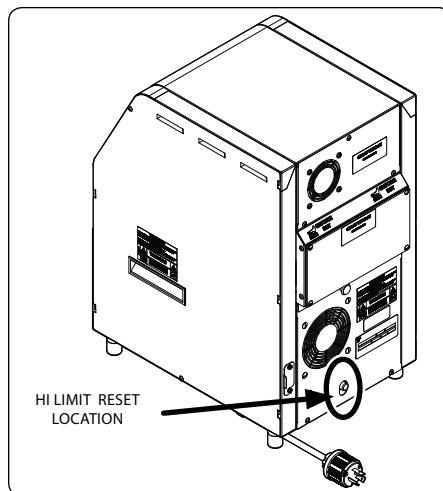

## MAINTENANCE

### WARNING

The unit will remain hot while it is cooling down. Personal injury and burns may result from touching the unit before it is finished cooling down. Wear Heat Resistant Gloves.

## DAILY MAINTENANCE

### Cleaning the Accessories and Toaster

1. Turn the toaster off. The unit enters a 20 minute cool down mode and displays OK to Clean when complete. The fans and conveyors continue to run. The cleaning mode continues for 20 minutes and shuts the unit down automatically when complete.

**NOTE:** You do not need to wait for the count down to complete. Continue with the cleaning steps as soon as you see OK to Clean.

2. Refer to Figure 3. Remove Crumb Tray and Bun Chute and set aside.
3. Wash the Crumb Tray and Bun Chute in soap and water. Rinse with clean water and allow to air dry.
4. Wipe all surfaces of the unit with a hot damp cloth.

**NOTE:** Do not use a dripping wet cloth. Wring out before use.

5. Wipe the bun landing area and Skirt Weldment with a hot damp cloth (Figure 3).
6. Inspect the Conveyor Belt Chain to ensure it is in good condition and is free of damage. If the chain requires replacement, refer to the section titled **Replacing the Conveyor Belt Chain**.
7. Refer to the two images in the next column. Make sure that both the front and rear Heat Damper Curtains are in place. Install the curtains if they are not in place. If they are in place, inspect, but do not remove, the front and rear curtains. Replace them if they are worn, damaged, or frayed.

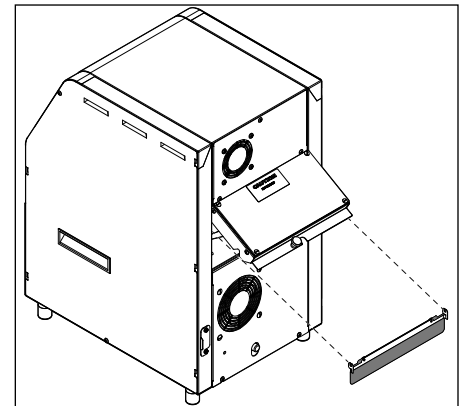
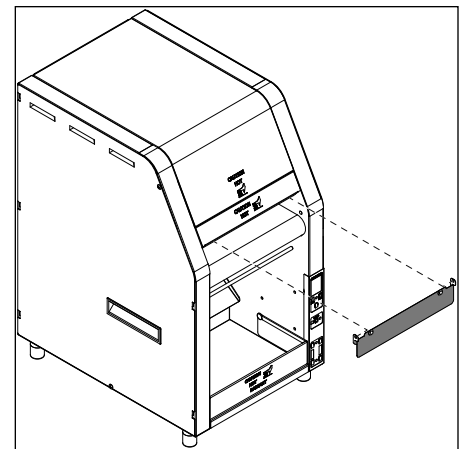



## QUARTERLY MAINTENANCE

Perform the steps in the **Daily Maintenance** section of this manual.

### Inspect Conveyor Belt Chain

Inspect the Conveyor Belt Chain to ensure it is in good condition and is free of damage.

Check the tension on the Conveyor Belt Chain. If the belt is sagging significantly or is dragging on the Crumb Tray Reflector, remove one or two links from the chain. Refer to the section titled **Adding/Removing Conveyor Belt Chain Links** for instructions.

### Measuring Conveyor Belt Chain

1. Turn the toaster off. The unit enters a 20 minute cool down mode and displays OK to Clean when complete. The fans and conveyors continue to run. The cleaning mode continues for 20 minutes and shuts the unit down automatically when complete.
2. Remove the Crumb Tray.

3. See the image below. Facing the front of the toaster, locate the front Idler Shaft. The Idler Shaft should be in the middle of the oval cut out.

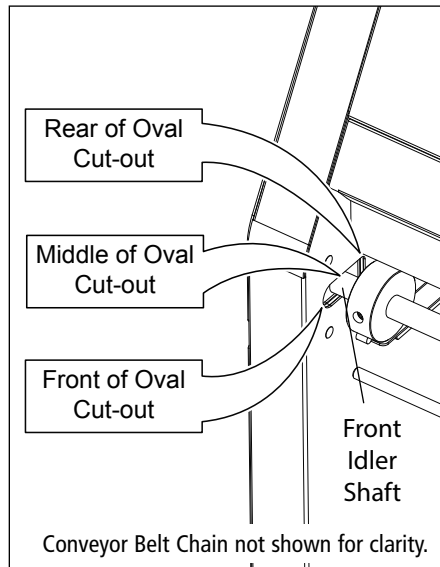

If the shaft is towards the front, remove a link.

If the shaft is towards the back, add a link.

If the shaft is in the middle, no action is needed.

If you need to add or remove a link, refer to the section titled **Adding/Removing Conveyor Belt Chain Links** in this manual.

## ERROR MESSAGES

If the toaster encounters an operating error, the unit displays **FAULT** and beeps. When this happens:

1. Press the **Day/Part** button to display the active error code.
2. Write down this error code and refer to the **Troubleshooting** section of this manual.

For assistance, call Antunes Technical Service at +1-877-392-7854.

Figure 3

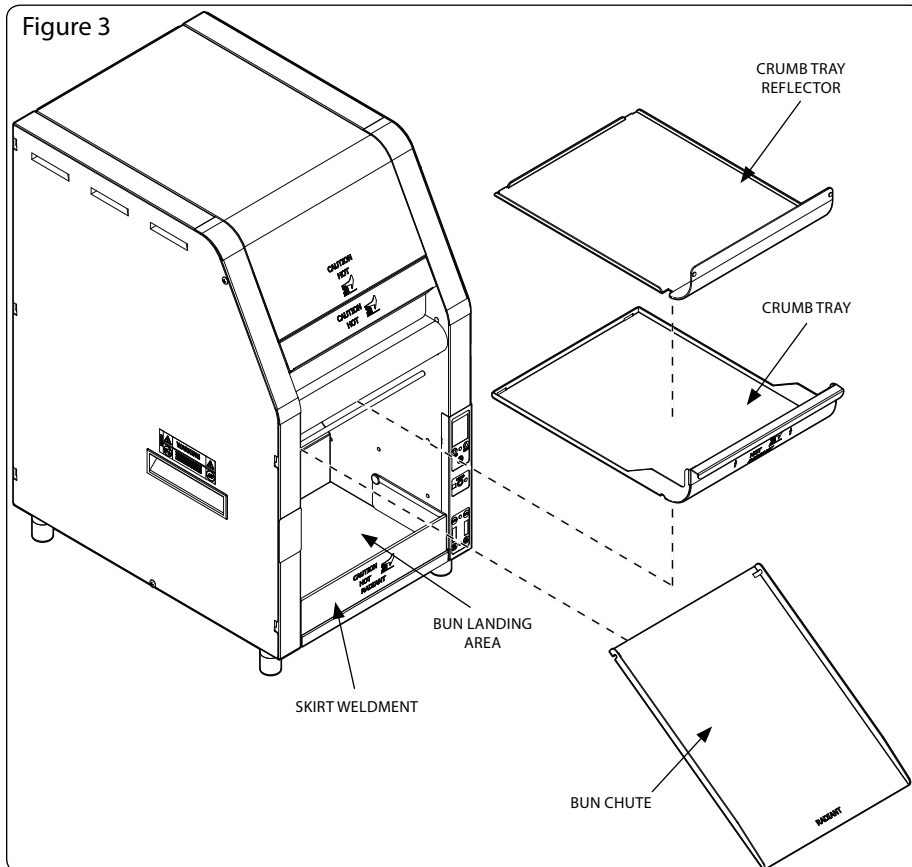

## CLEANING THE FANS

### Top Fan Cleaning

1. Turn the toaster off. The unit enters a 20 minute cool down mode and displays OK to Clean when complete. The fans and conveyors continue to run. The cleaning mode continues for 20 minutes and shuts the unit down automatically when complete.

**NOTE:** Be sure to wait until the unit shuts down before proceeding.

2. Facing the rear of the toaster, remove the three screws circled in the image below with a Phillips head screwdriver. Set the screws aside.

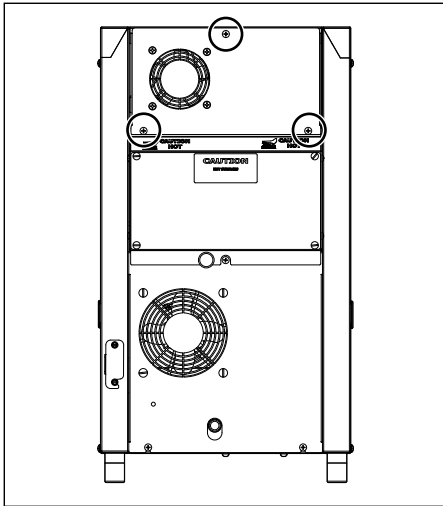

3. Rotate the Top Rear panel down to gain access to the top cooling fan.

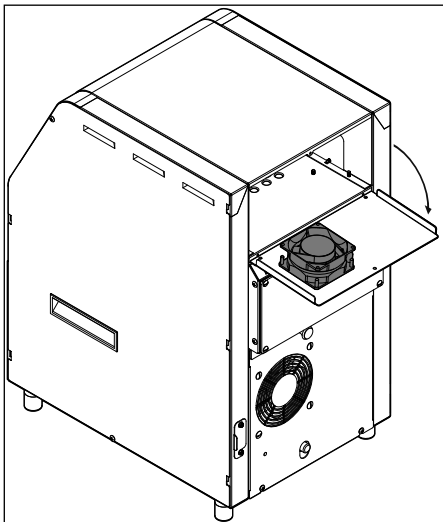

4. Clean the cooling fan with a small plastic brush or a clean dry cloth. Be sure to remove all debris from the fan blades.
5. Close the Top Rear panel and secure with the 3 screws.
6. Wipe the exterior portion of the top fan with a clean, damp towel. Make sure the fan opening is clear of any debris or obstructions.

### Bottom Fan Cleaning

1. Refer to the image below. Remove the top circled screw and set aside. Then, loosen but do not remove the 2 bottom circled screws.

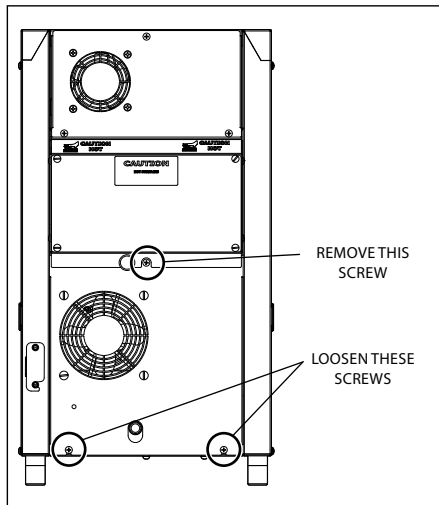

2. Lift the Rear Door to open (image below) and then lift up the Bottom Rear panel and rotate it so the bottom fan is accessible.

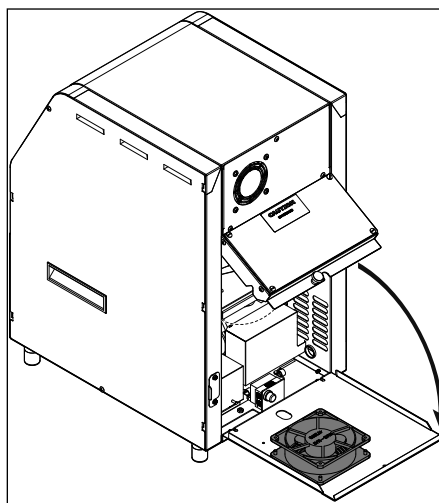

3. Clean the bottom cooling fan with a small plastic brush or a clean dry cloth. Be sure to remove all debris from the fan blades.
4. Place the Bottom Rear panel back into place, close the Rear Door, and secure the Bottom Rear Panel with screws.
5. Wipe the exterior fan opening with a clean, damp towel. Make sure the fan opening is clear of any debris or obstructions.

## ADDING/REMOVING CONVEYOR BELT CHAIN BELT CHAIN LINKS

Links from the Conveyor Belt Chain can be removed or added to keep the Conveyor Belt Chain at the right tension.

1. Turn the toaster off. The unit enters a 20 minute cool down mode and displays OK to Clean when complete. The fans and conveyors continue to run. The cleaning mode continues for 20 minutes and shuts the unit down automatically when complete.
2. Remove the Crumb Tray and Bun Chute.
3. Push the front of the Conveyor Shaft in and down so it locks into place. This removes tension from the Conveyor Belt Chain. Make sure both sides are locked in the in and down position.
4. Locate the two Master Links on the Conveyor Belt Chain (Figure 4).
5. Remove the master link on both the left and right side of the chain using needle-nose pliers. Flex the Master Links to remove them and set them aside temporarily.
6. Remove or add links as required.
7. Re-attach the Master Links on both the left and right side of the chain. This connects the two ends of the chain together (Figure 5).
8. Lift the front of the Conveyor up and out to restore tension to the Conveyor Belt Chain.
9. Re-install the Crumb Tray and Bun Chute.
10. Plug in the power cord and turn the unit on.

## REPLACING THE CONVEYOR BELT CHAIN.

Before you replace the Conveyor Belt Chain, make a note of how the existing chain is installed. The replacement chain must be installed in the same manner with the open end of the hooks facing opposite of the direction of travel (Figure 5).

1. Turn the toaster off. The unit enters a 20 minute cool down mode and displays OK to Clean when complete. The fans and conveyors continue to run. The cleaning mode continues for 20 minutes and shuts the unit down automatically when complete.
2. Remove the Crumb Tray and Bun Chute.
3. Push the front of the Conveyor Shaft in and down so it locks into place. This removes tension from the Conveyor Belt Chain. Make sure both sides are locked in the in and down position.
4. Locate the two Master Links on the Conveyor Belt Chain (Figure 4).
5. Remove the master link on both the left and right side of the chain using needle-nose pliers. Flex the Master Links to remove them.
6. Remove the existing Conveyor Belt Chain and discard.
7. Refer to Figure 5 and install the new Conveyor Belt Chain around the sprockets.
8. Connect the two ends of the Conveyor Belt Chain with the Master Links (Figures 4 and 5).
9. Lift the front of the Conveyor up and out to restore tension to the Conveyor Belt Chain.
10. Re-install the Crumb Tray and Bun Chute.
11. Plug in the power cord and turn the unit on.

Figure 4

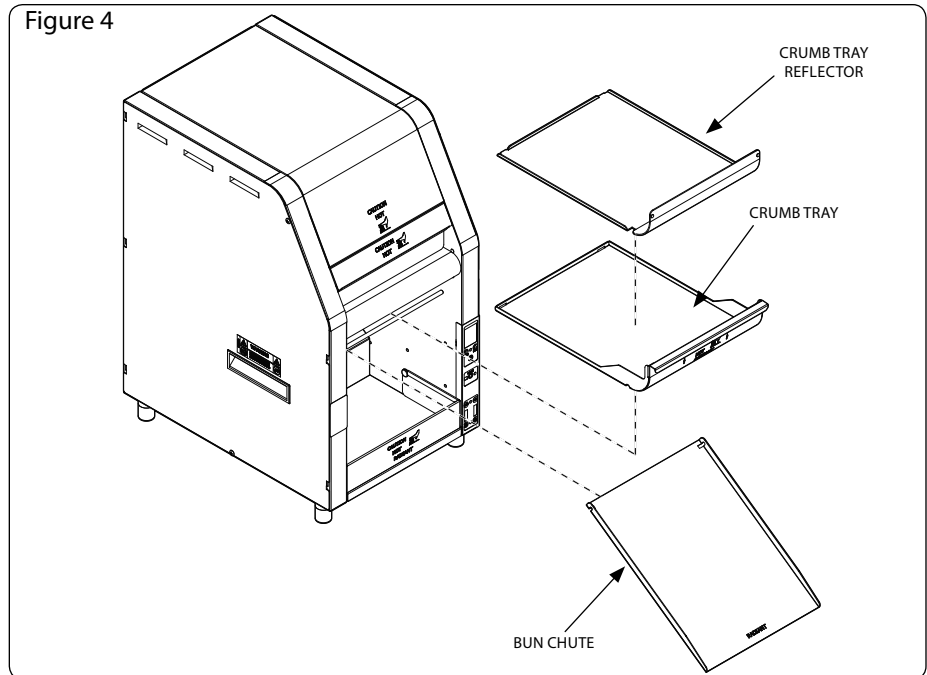
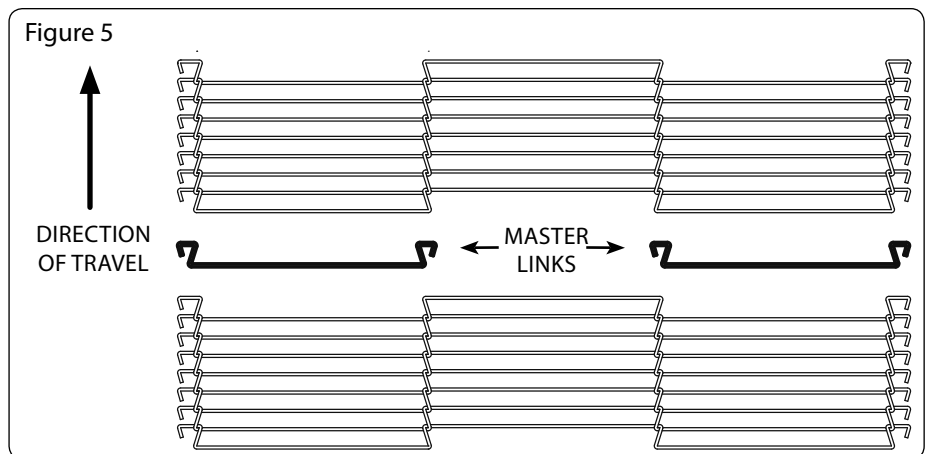

Figure 5



## TROUBLESHOOTING

Problem	Possible Cause	Corrective Action
No Control Display	Power cord not plugged in	Plug power cord into the proper electrical outlet
	Hi-Limit has tripped	Allow unit to cool and reset the Hi-Limit Control. If it trips again, contact Antunes Technical Service at +1-877-392-7854.
	Circuit breakers turned off or tripped. Damaged electrical outlet, plug, or cord. Power switch damaged	Reset circuit breakers. If they trip again, check the power cord, plug, and outlet for damage. Contact Antunes Technical Service at +1-877-392-7854.
	Faulty or misaligned communication cable	Replace or align communication cable.
	Faulty Transformer	Replace transformer.
Conveyor does not turn on	Conveyor Belt/Chain has stretched. Chain skipping on sprockets.	Measure and adjust the conveyor belt chains as described in the Maintenance section of this manual.
	Loose sprocket	Verify setscrew is tight on flat part of shaft.
	Motor Drive Chain came off sprocket(s)	Reinstall drive chain.
	Internal part /object interfering within conveyor system	Check for interference & clear up as necessary.
	Drive chains need lubrication.	Lubricate chain.
Conveyor(s) hesitate	Loose or misaligned sprocket	Align and tighten set screw on sprocket.
	Motor drive chain loose or stretched	Replace or tighten up slack on drive chain.
	Drive motor(s) have failed	Contact Antunes Technical Service at +1-877-392-7854.
Crowns and/or Heels must be forced into the toaster. Buns sticking and burning.	Conveyor Belt/Chains are skipping on sprockets.	Adjust the conveyor belt chains according to the Maintenance section of this manual.
	Drive motor stalls intermittently.	Contact Antunes Technical Service at +1-877-392-7854.
Toaster making unusual sounds	Conveyor belt chains have stretched or adjusted incorrectly.	Adjust the conveyor belt chains as described in the Maintenance section of this manual.
	Motor Drive chain needs lubrication.	Lubricate chain.
	Conveyor shaft bearing is binding.	Contact Antunes Technical Service at +1-877-392-7854.
Fans are making an unusual sounds	Failed cooling Fans	Verify vents on toaster are unblocked and not near other heating appliances. Clean Fans. If error persists, contact Antunes Technical Service at +1-877-392-7854.
	Cooling Fans are dirty and need to be cleaned	
Display reads <b>"Hi-Limit Tripped"</b> .	Hi-Limit has tripped.	Allow sufficient time (10-15 minutes) for the unit to cool down. Remove the Hi-Limit control cap at the rear of the unit. Press the Hi-Limit Reset button. Turn the unit on and test the unit by toasting some test product. If the Hi-Limit continues to trip, contact Antunes Technical Service at +1-877-392-7854 for assistance.
Display reads <b>"Motor Running Slow"</b> .	A mechanical obstruction has occurred that is slowing down the conveyor motor.	Check the bottom wire conveyor and surrounding areas for any obstructions/jams. Contact Antunes Technical Service at +1-877-392-7854.
	Wire Conveyor Belt is too loose/sagging & getting jammed.	If sagging is noticeable, remove the necessary links to shorten the Wire Conveyor Belt. Refer to the Maintenance section in this manual. Contact Antunes Technical Service at +1-877-392-7854.
	Wire Conveyor Belt is broken/damaged and jammed.	Replace the wire belt according to the Maintenance section of this manual. Contact Antunes Technical Service at +1-877-392-7854.
Display Reads <b>"High Intern Temps"</b> .	Toaster electrical compartment is overheating due to the lack of airflow surrounding the toaster.	Inspect the cooling at the top and at the bottom (back of unit) and ensure it is clean according to the fan cleaning portion of the Maintenance section of this manual. Make sure the unit has enough space on both sides and the rear of the unit according to the Installation section of this manual. If the condition continues, contact Antunes Technical Service at +1-877-392-7854.
Display reads <b>"Top IR Fault"</b>	Failed Heater or Solid State Relay.	Contact Antunes Technical Service at +1-877-392-7854.
Display reads <b>"Bottom IR Fault"</b>		
Display reads <b>"Air Fault"</b>		
Display reads <b>"Fault T/C"</b>		
Display reads <b>"Overtemp"</b>		
Display reads <b>"Conv Fan Fault"</b>	Upper Cooling Fan dirty or faulty.	Inspect the cooling at the top and at the bottom (back of unit) and ensure it is clean according to the fan cleaning portion of the Maintenance section of this manual. Make sure the unit has enough space on both sides and the rear of the unit according to the Installation section of this manual. If the condition continues, contact Antunes Technical Service at +1-877-392-7854.
Display reads <b>"No Motor Found"</b>	Low voltage, check incoming power.	Contact Antunes Technical Service at +1-877-392-7854.

# REPLACEMENT PARTS

Item	Part No.	Description	Qty.
1	0012994	Assy, Bearing Cover	2
2	7001069	Curtain Assembly Kit	1
3	0013010	Back Panel Assembly	1
4	0013124	Contacto Bracket Assy	1
4a	0507182	Ele Mt Bracket	1
4b	3020133	Rivet, Plastic .026"-.062"	2
4c	3020134	Rivet, Snap W/ 7/16" Nylon Spacer	2
4d	3080203	Screw, Tap 8-32 X 3/8" W/Int. Tooth Washer	2
4e	7001017	Contacto, 2 Pole NO	1
4f	4070227	Snubber Board	1
5	0021898	Wldmnt, Bearing Brkt & Spring Guide - Rh	1
6	0021899	Wldmnt, Bearing Brkt & Spring Guide - Lh	1
7	0021967	Ramp Weldment	1
8	0021968	Top Coil Mt Wldmt	1
9	0021969	Main Coil Mt Weldment	1
10	0021970	Lower Heater Mt Weldment	1
11	0021971	Control Housing Wldmt	1
12	0021972	End Housing Weldment	1
13	0021973	Back Panel Wldmt	1
14	0021975	Skirt Weldment	1
15	0200327	Silicone Strip 6"	2
16	0200328	Silicone Strip 12"	2
17	0400147	Bushing, Shorty 7/8"	3
18	040P265	Bushing, Shorty 3/8"	18
19	0400414	Insulator, 1/2" Ceramic Female	6
20	0400459	Spacer, 1.125 Od X .25 Id X .03 Thk Nomex	6
21	0400463	Cover, Contacto	1
22	0400464	Cover, Motor Board	1
23	050K128	Bracket, Sensor	1
24	0506612	Plate, Tensioner	2
25	0506658	Retainer, Capillary Bulb	1
26	0506743	Access Cover One Fan	1
27	0506744	Plate, Top Housing	1
28	0506746	Bracket, Motor	1
29	0506747	Top Housing Radiant	1
30	0506748	Cover Channel End Housing	1
31	0506749	Cover Lower	1
32	0506750	Cover Channel Control Hsg	1
33	0506751	Cover Upper Coil	1
34	7001089	Tray, Crumb	1
35	0506772	Reflector, Rh	1

Item	Part No.	Description	Qty.
36	0506773	Reflector, Lh	1
37	0506785	Wall Cool	1
38	0506786	Bun Ramp	1
39	0506789	Control Housing Panel	1
40	0506790	End Housing Panel	1
41	0506791	Heater Cover	1
42	0506792	Heater Base	1
43	0506799	Retainer, Bearing	2
44	0507073	Bracket, Usb Mounting	1
45	0507162	Bezel, Label Retainer	1
46	0507175	Retainer, Heater Element	8
47	0507181	Retainer, Heater Element	4
48	0507193	Shield, Reflector	2
49	0507194	Cover, Usb	1
50	0507198	Reflector, Crumb Tray	1
51	0600141	Spring, Compression	2
52	0800444	Connecting Link, Chain	2
53	0800463	Rod 1/4 X 10 Inch	2
54	0800464	Rod 3/8 X 10 Inch	1
55	7001010	Conveyor Kit	1
56	1001548	Label, Control	1
57	21000-0046	Standoff, 1/4" Locking Pcb	4
58	2100212	Handle, Pocket Pull, Snap-In	2
59	210K230	Bumper, Recess W/Washer	4
60	2100334	Thrust Strip, Teflon	2
61	211P195	Hose Clamp Pkg of 10	2
62	2110197	Clip, Steel Cable	1
63	2120143	Spacer, #4 X .25Lg	5
64	2120147	Spacer, Leg	4
65	2120249	Spacer, .115 Id X .25 Od .062 Thk Nylon	4
66	2150179	Sprocket, 25B14 1/2" Bore	1
67	7000224	Bearing and Retainer Kit	1
68	2150251	Sprocket, 25B14 3/8" Bore	1
69	2150254	Roller	4
70	7001004	Bearing Kit	2
71	2150277	Sprocket, Drive 17 Tooth	2
72	2150352	Shaft, Drive	1
73	2150353	Shaft, Idler	1
74	2150369	Drive Chain	1
75	218P145	Cover, Bumper	4
76	300P123	Ring, Retaining, External	1
77	3010101	Weld Nut-Twin #8-32	1
78	30400-0010*	Nut, #4-40 Nylon	1
79	3040123*	Screw, Mach #4-40 X 3/8" Panhd Phillips 1	1

Item	Part No.	Description	Qty.
80	306P130*	Nut, Hex Keps #6-32 (Small Pattern)	1
81	308P101*	Nut, Hex #8-32	1
82	308P115*	Screw, Mach. #8-32 X 3/8"	1
83	308P193*	Scr, Mach #8-32 X 1 1/4" Slitlthd	1
84	308P203*	Screw, Tap 8-32 X 3/8" W/Int. Tooth Washer	1
85	308P227*	Scr Mach #8-32 X 3/8" Hxhdsltd; Shoulder	1
86	308P344*	Stnd-Off #8-32 X 3/8 M/F	1
87	310P108*	Screw, Mach. #10-32 X 1/2"	1
88	310P110*	Screw, Mach. #10-32 X 1/2"	1
89	310P146*	Nut, Hex 'Keps' #10-32	1
90	310P180*	Screw, Mach. #10-32 X 1-3/4"	1
91	310P187*	Screw Set, #10-32 X 3/8 Hex Socket-Con Point	1
92	310P199*	Scr, #10-32 X 3/8 Lg Socket Hd Cap	1
93	310P213*	Screw, Phphhd #10-16 X 3/4" Thrd Form 1	1
94	310P215*	Scr, Shldr #10-32 X 1/4" W/1/4" Shldr Precision	1
95	325P163*	Set Screw, 1/4-28 X 5/16"	1
96	7001146	Fan Blower Kit	1
97	7000913	Fan Kit	1
98	7001041	Motor Kit	1
99	7001145	Transformer Kit 240 Vac/12Vac	1
100	4030332	Thermostat, Hi-Limit	1
101	4030438	Heater, Cfa	2
102	7001012	Heater Kit	1
103	4030440	Heater, Foil 208V, 50W	1
104	4050180	Heat Sink	2
105	4050234	Thermocouple, Type K (Open End)	1
106	7001143	Relay Kit	1
107	7001143	Relay Kit	1
108	7001090	Thermocouple Kit	1
109	4060234	Wire Strap - 3/8"	2
110	4060398	Terminal Block, S-Series	1
111	4060451	Usb, A-F Pnl Mount/A-M Shield	1
112	4070154	Varistor Board	1
113	7001040	Motor Board Kit	1
114	4070216	Current Sense Board	1
115	7001007	Control Board Kit	1
116	7001085	Main Board Kit	1
117	0400437	Strain Relief, Rt. Angle	1
118	0700479	Power Cord T/Lock L6-30P	1

\*Available in packages of 10 (ten).

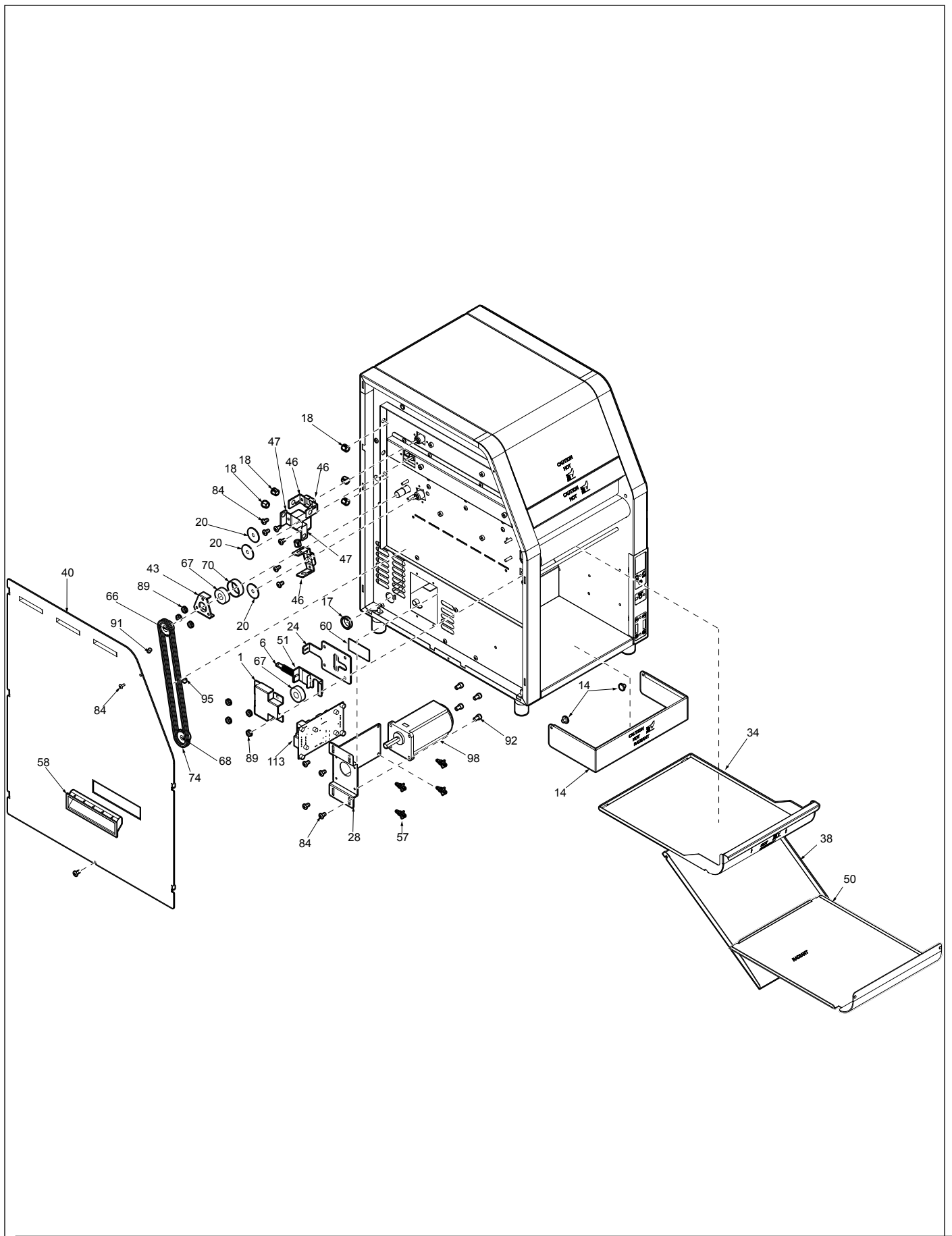

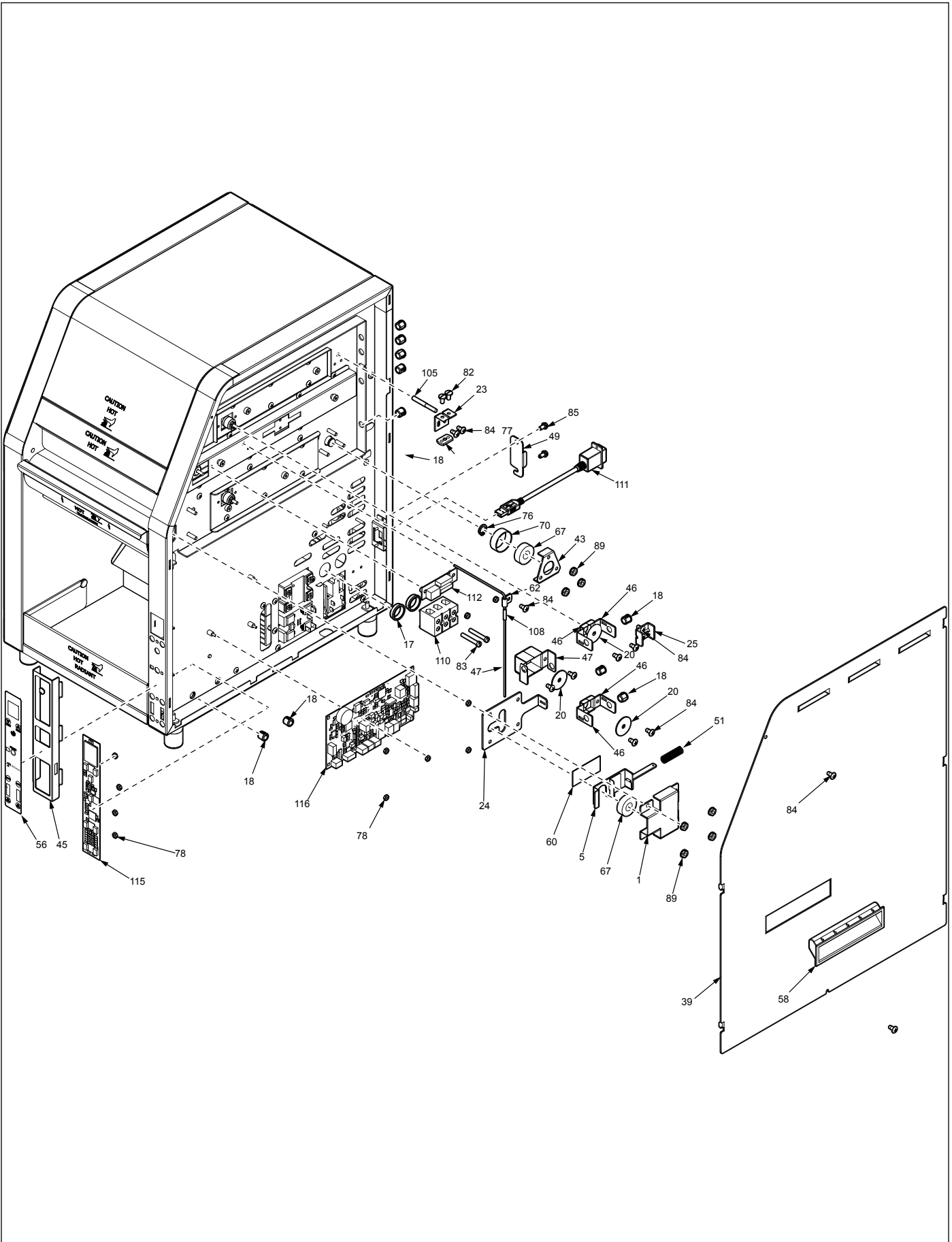

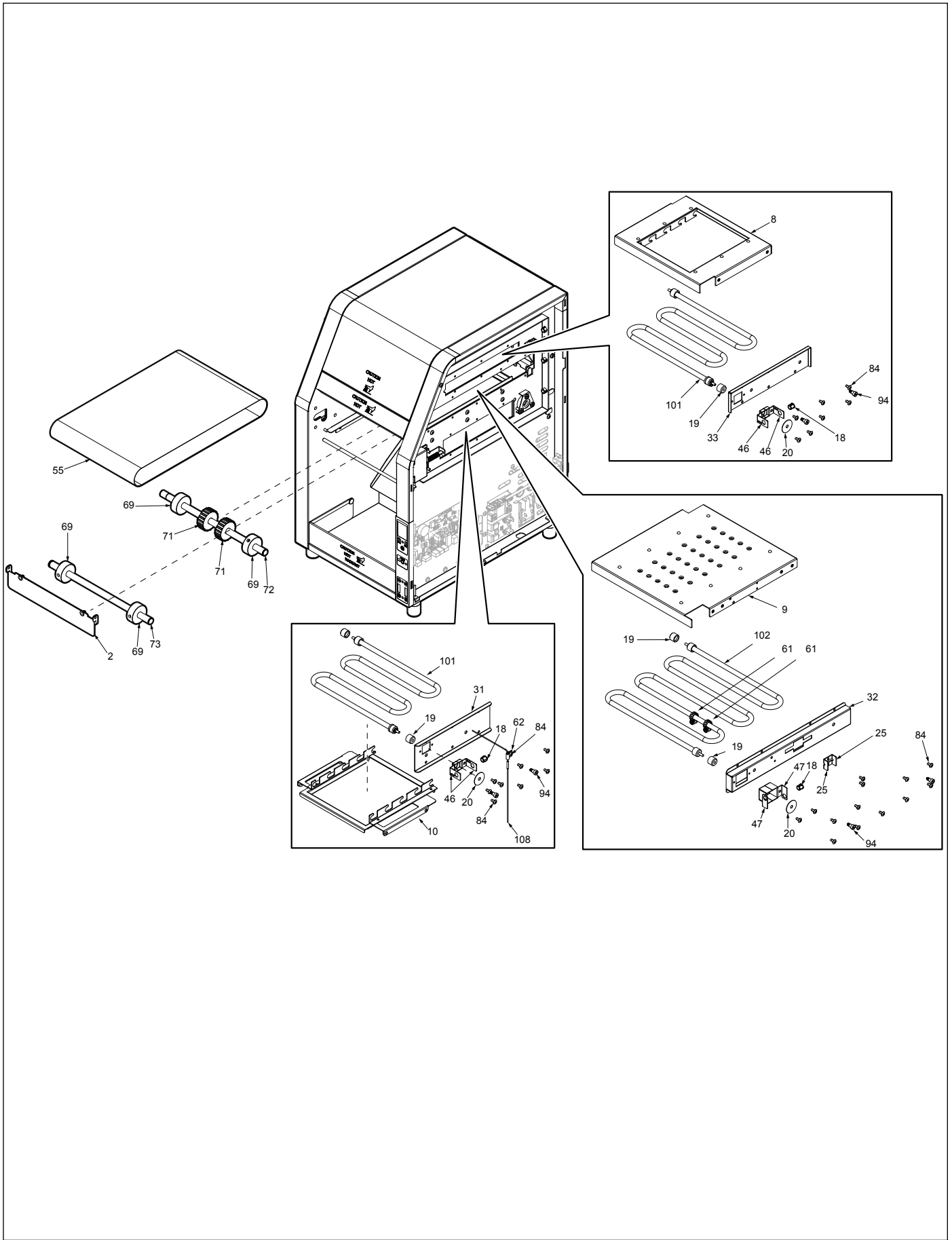



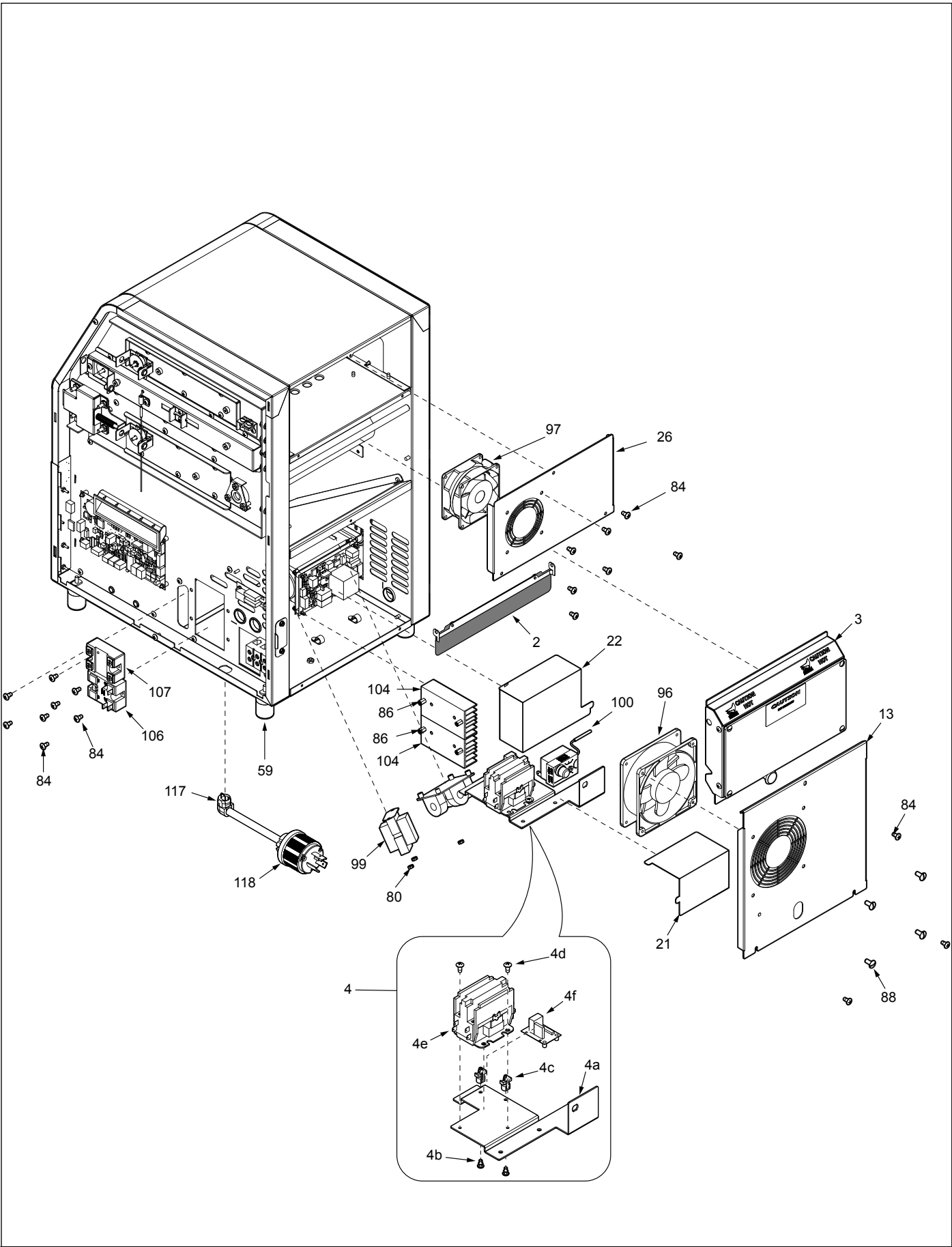

# WIRING DIAGRAM

## WIRING DIAGRAM

- △ 12 GA XLP 125°C
- ▲ 14 GA TFE 200°C
- 14 GA XLP 125°C
- 18 GA PVC 105°C
- 20 GA XLP 125°C
- \* 22 GA XLP 125°C
- 22 GA TFE 200°C

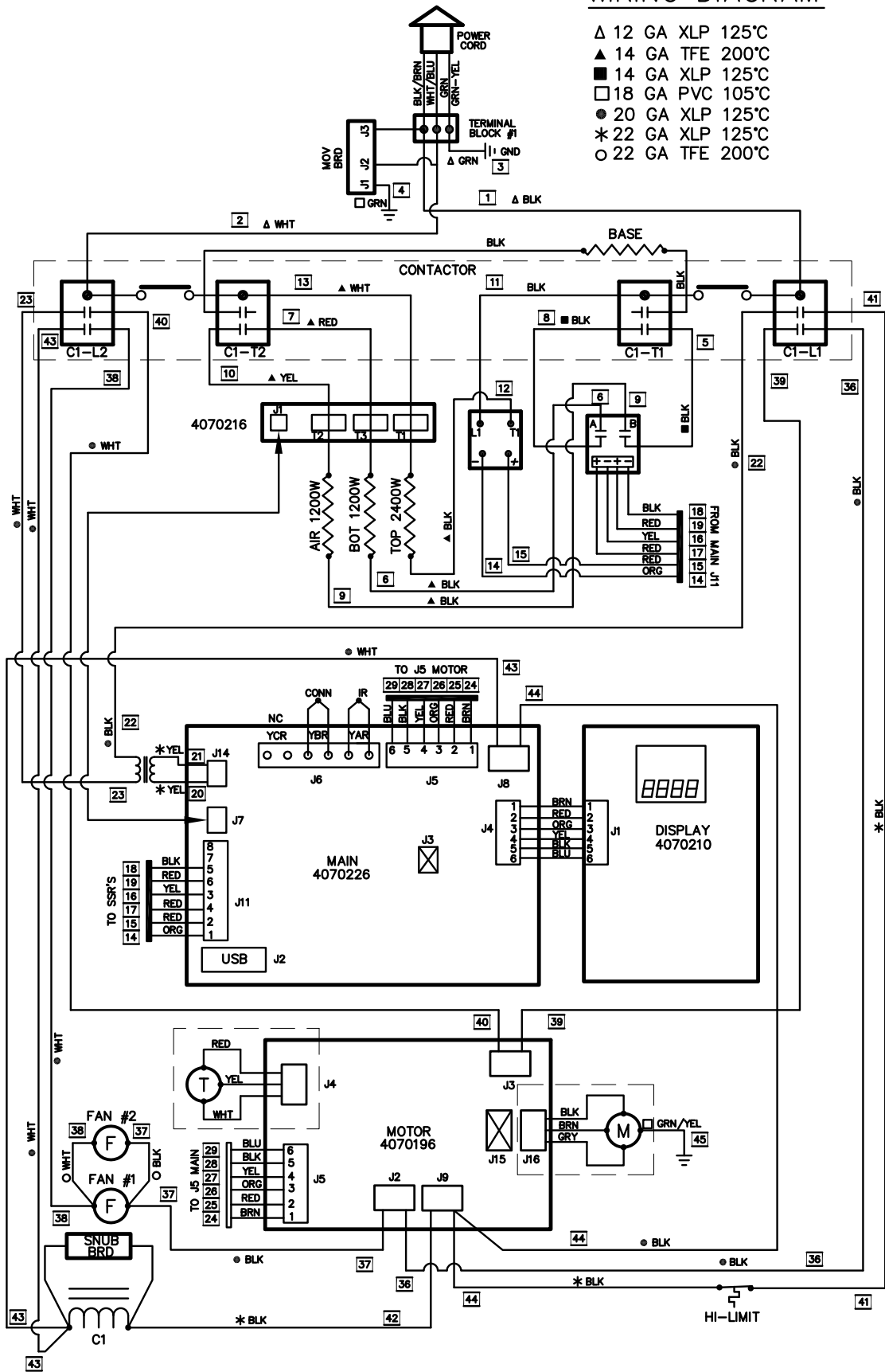

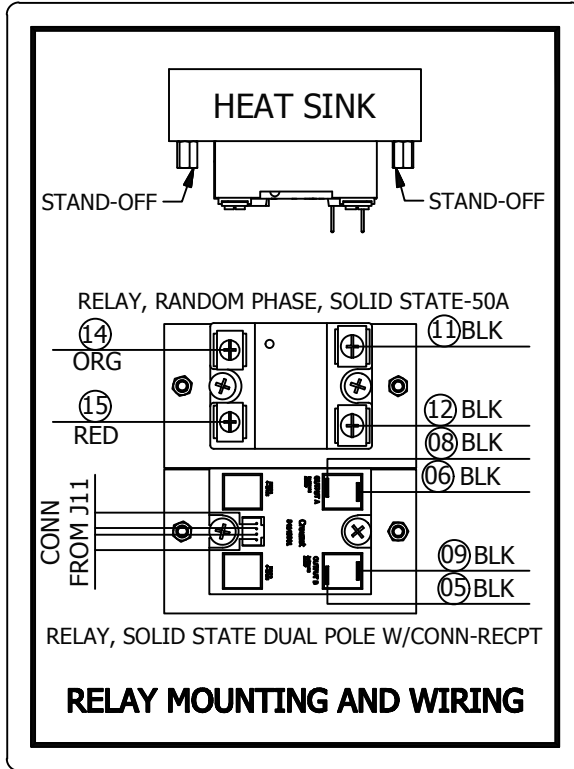

## LIMITED WARRANTY

Equipment manufactured by A.J. Antunes & Co. has been constructed of the finest materials available and manufactured to high quality standards. These units are warranted to be free from electrical and mechanical defects for a period of two (2) years from date of purchase under normal use and service, and when installed in accordance with manufacturer's recommendations. To insure continued operation of the units, follow the maintenance procedures outlined in the Owner's Manual. During the first 12 months, electro-mechanical parts, non-overtime labor, and travel expenses up to 2 hours (100 miles/160 km), round trip from the nearest Authorized Service Center are covered. During the second year of this warranty (months 12 - 24), the following items are covered by a Part Only warranty: Drive Motor, Motor Board, Current Sense Board, Display Board, and Main Board.

1. This warranty does not cover cost of installation, defects caused by improper storage or handling prior to placing of the Equipment. This warranty does not cover overtime charges or work done by unauthorized service agencies or personnel. This warranty does not cover normal maintenance, calibration, or regular adjustments as specified in operating and maintenance instructions of this manual, and/or labor involved in moving adjacent objects to gain access to the equipment. This warranty does not cover consumable/wear items such as Release Sheets (if present), Conveyor Belt Chain Link removal, Belt Wraps, and Dampers. This warranty does not cover damage to the Platen due to operating the toaster without a Release Sheet when required or cleaning with abrasive cleansers or tools, misuse or dropping of unit. This warranty does not cover problems or failures resulting from improper/incorrect voltage supply. This warranty does not cover Travel Time & Mileage in excess of 2 hours (100 miles/160 km) round trip from the nearest authorized service agency.
2. A.J. Antunes & Co. reserves the right to make changes in design or add any improvements on any product. The right is always reserved to modify equipment because of factors beyond our control and government regulations. Changes to update equipment do not constitute a warranty charge.
3. If shipment is damaged in transit, the purchaser should make a claim directly upon the carrier. Careful inspection should be made of the shipment as soon as it arrives and visible damage should be noted upon the carrier's receipt. Damage should be reported to the carrier. This damage is not covered under this warranty.
4. Warranty charges do not include freight or foreign, excise, municipal or other sales or use taxes. All such freight and taxes are the responsibility of the purchaser.
5. This warranty is exclusive and is in lieu of all other warranties, expressed or implied, including any implied warranty or merchantability or fitness for a particular purpose, each of which is hereby expressly disclaimed. The remedies described above are exclusive and in no event shall A.J. Antunes & Co. be liable for special consequential or incidental damages for the breach or delay in performance of this warranty.



### Corporate Headquarters

Carol Stream, Illinois

Phone: +1 (630) 784-1000

Toll Free: +1 (800) 253-2991

Fax: +1 (630) 784-1650

### China Facility

Suzhou, China

Phone: +86-512-6841-3637

Fax: +86-512-6841-3907