

Water Filtration System

Model UFL-410 Series owner's manual

Manufacturing Numbers:

9700459

CONTENTS

General	2
Warranty Information	2
Service/Technical Assistance	2
Important Safety Information	3
Specifications	4
Electrical Cord & Plug	4
Configurations	4
Electrical Ratings	4
Replacement Cartridges	4
Performance Data Sheet	6
Filter Cartridge Capacities	6
Overview	7
Manual Flushing	7
Installation	8
Unpacking	8
Equipment Setup	8
Mounting the System	8
Inlet Water Plumbing	8
Permeate Line Plumbing	9
Drain Valve Connection	9
Starting the Controller	9
Rinsing the Ultra Filter Cartridge	9
Sanitizing the System and Lines	10
Maintenance	11
Replacing the Ultra Filter Cartridge	11
System Sanitization	11
Changing the Interval Setting	12
Resetting the Timer Program	12
Troubleshooting	13
Notes	15
Limited Warranty	16

GENERAL

This manual provides important safety, installation, and operating procedures. All information contained in this manual should be read prior to installing and operating the system.

This system is manufactured from the finest materials available and is assembled to strict quality standards. This system has been tested at the factory to ensure dependable trouble-free operation.

WARRANTY INFORMATION

Please read the full text of the Limited Warranty in this manual.

If the system arrives damaged, contact the carrier immediately and file a damage claim with them. Save all packing materials when filing a claim. Freight damage claims are the responsibility of the purchaser and are not covered under warranty.

The warranty does NOT extend to:

- Damages caused in shipment or damage as result of improper use.
- Installation of electrical service.
- Normal maintenance as outlined in this manual.
- Malfunction resulting from improper maintenance.
- Damage from moisture leaking into electrical components.
- Damage from tampering with, removal of, or changing any preset control or safety device.

SERVICE/TECHNICAL ASSISTANCE

If you experience any problems with the installation or operation of your system, contact A.J. Antunes & Co. at 1-630-784-1000, or toll free in the United States at 1-800-253-2991.

Fill in the information in the next column and have it handy when calling for assistance. The serial number is on the specification plate located on the system.

Purchased From

Date of Purchase

Model Number

Serial Number

Mfg. Number

Suggested replacement period for the Ultra Filter Cartridge is approximately 3 years.

For sales in the state of Iowa:

Seller:

Date:

Buyer:

Date:

IMPORTANT

A.J. Antunes & Co. reserves the right to change specifications and product design without notice. Such revisions do not entitle the buyer to corresponding changes, improvements, additions or replacements for previously purchased equipment.

IMPORTANT

Keep these instructions for future reference. If the unit changes ownership, be sure this manual accompanies the equipment.

CAUTION

All electrical connections must be in accordance with local electrical codes and any other applicable codes. A ground fault circuit interrupter (GFCI) must be installed on the circuit to this system. When installed on metallic plumbing, a properly sized electrical bonding jumper must be installed across the inlet and outlet pipes serving this unit.

IMPORTANT

This equipment is to be installed to comply with the basic plumbing code of the Building Officials and Code Administrators, Inc. (BOCA) and the Food Service Sanitation Manual of the Food and Drug Administration (FDA).

IMPORTANT

Water Flow Regulator Assemblies are NOT interchangeable. Operating the system with the wrong Water Flow Regulator or without a regulator can damage the system, cause personal injury, and voids the warranty!

IMPORTANT SAFETY INFORMATION

In addition to the warnings and cautions in this manual, use the following guidelines to safely operate the system:

- Read all instructions before using equipment.
- Install or locate the equipment only for its intended use as described in this manual.
- Do NOT use corrosive chemicals in this equipment.
- Do NOT operate this equipment if it has a damaged cord or plug; if it is not working properly, or if it has been damaged or dropped.
- This equipment should be serviced by qualified personnel only. Contact A.J. Antunes & Co. for repair.
- Do NOT immerse cord or plug in water.
- Keep cord away from heated surfaces.
- This equipment should be supplied with only cold water.
- For installations in Massachusetts, the Commonwealth of Massachusetts Plumbing Code 248 CMR shall be adhered to. The use of saddle valves are not permitted. Please consult your local plumber.

The following warnings and cautions appear throughout this manual and should be carefully observed.

- Unplug the power cord before performing any service or maintenance on the unit.
- All electrical connections must be in accordance with local electrical codes and any other applicable codes.
- Warning electrical shock hazard. Failure to follow these instructions could result in serious injury or death.
- Do NOT modify the power supply cord plug. If it does not fit the outlet, have a proper outlet installed by a qualified electrician.
- Do NOT use an extension cord with this unit.
- If the supply cord is damaged, it must be replaced by the manufacturer, its service agent, or a similarly qualified person.
- This equipment is to be installed to comply with the local plumbing code and any other applicable code.

- Water pressure must not exceed 100 psig (690 kPa). To reduce water pressure, install a water pressure regulator and set to suit the application.
- The trans membrane pressure (inlet pressure minus the permeate water pressure) must not exceed 45 psi (310 kPa).
- A ground fault circuit interrupter (GFCI) must be installed on the circuit to this system.
- When installed on metallic plumbing, a properly sized electrical bonding jumper must be installed across the inlet and outlet pipes serving this unit.

Protect from becoming dry

If the membrane dries out, irreversible damage to the Ultra Filter membrane may result. Protect the filter from becoming dry by keeping it wet and sealed at all times.

Protect from freezing

If the Ultra Filter membrane freezes during operation or storage, irreversible damage to the membrane and brittle cracking of the cartridge or housing may result.

Protect from direct sunlight or other UV sources

Avoid long-term exposure to direct sunlight or other UV sources. The Ultra Filter should be stored in a dark location.

Protect from high temperatures or abrupt variation in temperature

The maximum operating temperature is 104°F (40°C). Avoid abrupt variations in temperature. Any temperature variation should be made slowly.

Protect from rough handling or dropping

Mechanical damage, external breakage, and/or internal breakage of the filter can result if the system is dropped or bumped. Handle with care at all times during transportation and installation.

Protect from organic solvents and concentrated acids

Prevent any and all contact of the membrane with strong solvents, solvents containing chlorine, or concentrated acids. Do NOT use strong solvents or concentrated acids on any plastic parts of the filter system. Examples of some solvents to avoid: acetone, methyl acetate (nail polish remover); hexane (spot removers); turpentine, toluene (paint thinners); dry cleaning solutions, insecticides.

Protect from abrasive material

The membranes must be protected from abrasive materials like shavings left in a pipe. Abrasive materials in contact with the membrane can cause irreversible damage to the membrane. All pipes must be flushed clean before installing the filter. All plastic parts of the filter system must be protected from sharp objects like knives, sand paper, or other tools. Cutting or nicking a plastic part can weaken it and cause a leak. Do NOT use abrasive cleansers on any plastic parts.

Protect from water hammer

The system must be protected from shock, pressure surges, or pulsation that may occur inside water pipes. Water hammer occurs in pipes when a valve or faucet shuts quickly. Install a water hammer arrestor (pressure vessel containing compressed air separated from the water by a diaphragm) to reduce pressure shock.

SPECIFICATIONS

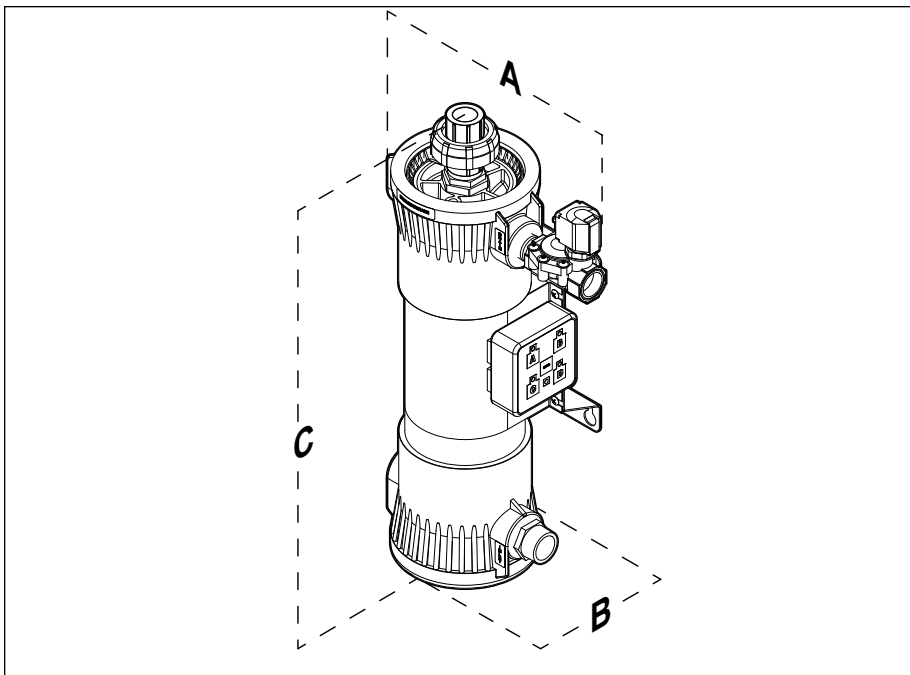

Model & Mfg. No.	Width (A)	Depth (B)	Height (C)	Operating Weight
UFL-410 9700459	11.5" (29 cm)	6" (15 cm)	20" (51 cm)	20 lbs. (9.1 kg)

Electrical Cord & Plug Configurations

Kit Model Number	Description	Configuration
0012146	DC Power Supply 100 - 240 VAC Includes the 4 plug adaptors below	 <small>NOTE: PLUG STYLE MAY VARY</small>
	US NEMA 1-15 (2 pin) or NEMA 5-15 (3 Pin)	
	Euro CEE 7/16	
	AS/NZS 3112 AUS (2 Pin)	
	UK BS 1363	

Electrical Ratings

Model & Mfg. No.	Volts	Watts	Amps	Hertz
UFL-410 9700459	100-240	10	.04	50/60

Replacement Cartridges

Replacement		Part Number
UFL-410	L-410 Ultra Filter	7000839

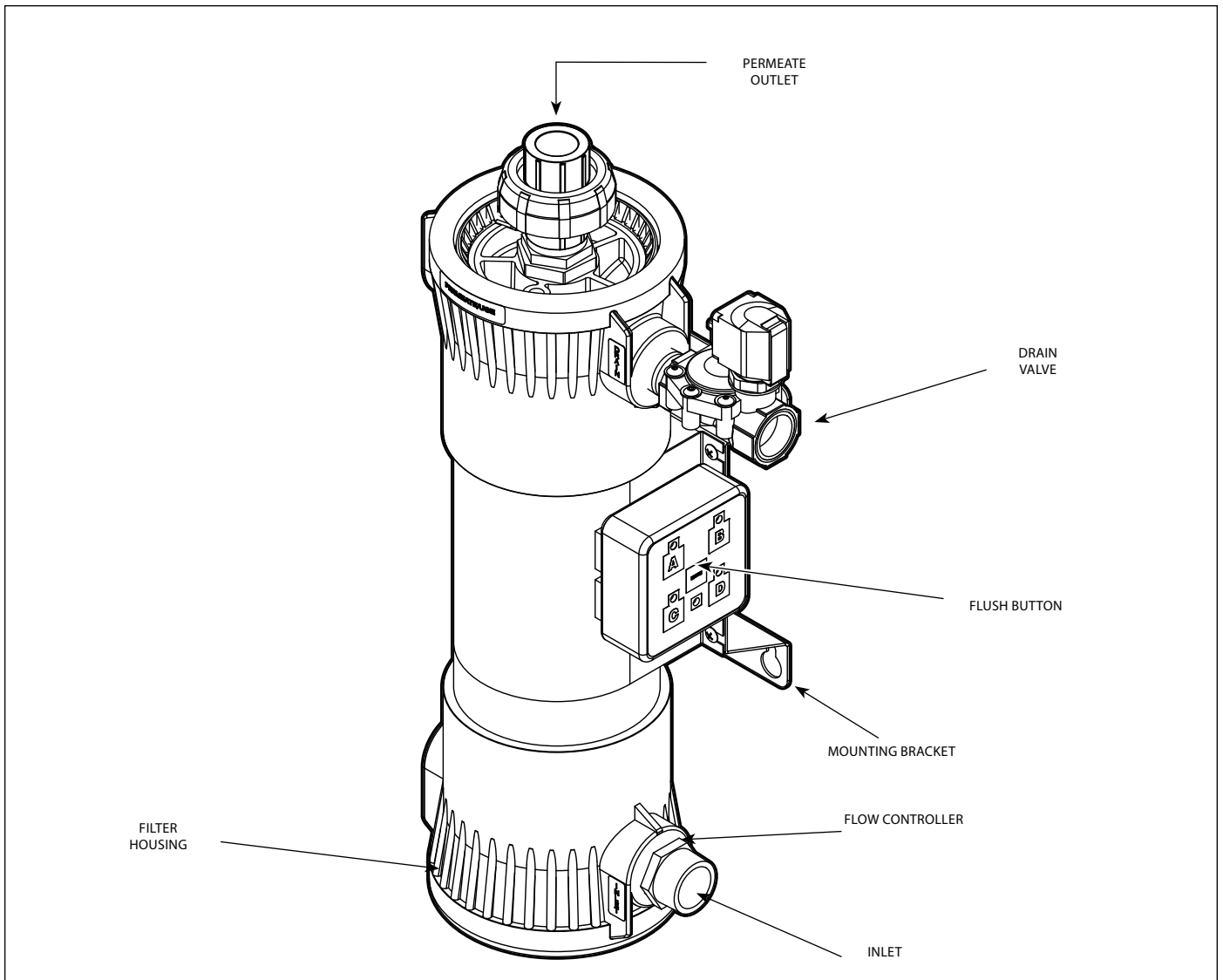

Figure 1. Components

PERFORMANCE DATA SHEET

Filter Cartridge Capacities

Maximum Operating Pressure	100 psig (690 kPa)
Maximum Operating Temperature	104°F (40°C)
Minimum Operating Temperature	40°F (4°C)
Maximum Trans Membrane Pressure	45 PSI (3.1 Bar)
pH Range	3-10
MWCO	100 kD

Do not use with water that is microbiologically unsafe or of unknown quality without adequate disinfection before or after the system. Systems certified for cyst reduction may be used on disinfected waters that contain filterable cysts.

OVERVIEW

The UFL system operates in two modes:

- Normal Operation Mode
- Flush Mode

During Normal Operation Mode, water enters the Inlet and flows through the Ultra Filter before exiting the Permeate Outlet as usable product water.

During Flush Mode, the Drain Valve opens and water entering the Inlet flushes and cleans the Ultra Filter membrane by removing any debris collecting on the membrane wall.

The Drain Valve is only powered during Flush Mode.

NOTE: Do NOT unplug the power cord or turn off the system during Flush Mode. If there is a power outage or the system is unplugged, water will continue to be filtered but the system will NOT flush. This could cause the Ultra Filter to plug prematurely and may reduce the life of the filter.

The flush is automated by the controller to last 10 seconds and take place in one hour intervals. This interval can be changed (see Changing the Interval Setting in the Maintenance section of this manual).

CAUTION

Changing the flush interval may cause the Ultra Filter to plug prematurely and may reduce the life of the filter. Consult the factory for more information.

Manual Flushing

A manual flush can be activated at any time by pressing the FLUSH button on the Universal Pulse Controller.

When the FLUSH button is pressed, the Flush LED on the controller flashes and the Drain Valve opens for 10 seconds. After flushing is complete, the Drain Valve will close, the Flush LED will stop flashing, and the unit automatically returns to Normal Operation Mode.

NOTE: A Manual Flush will not affect the interval flush setting.

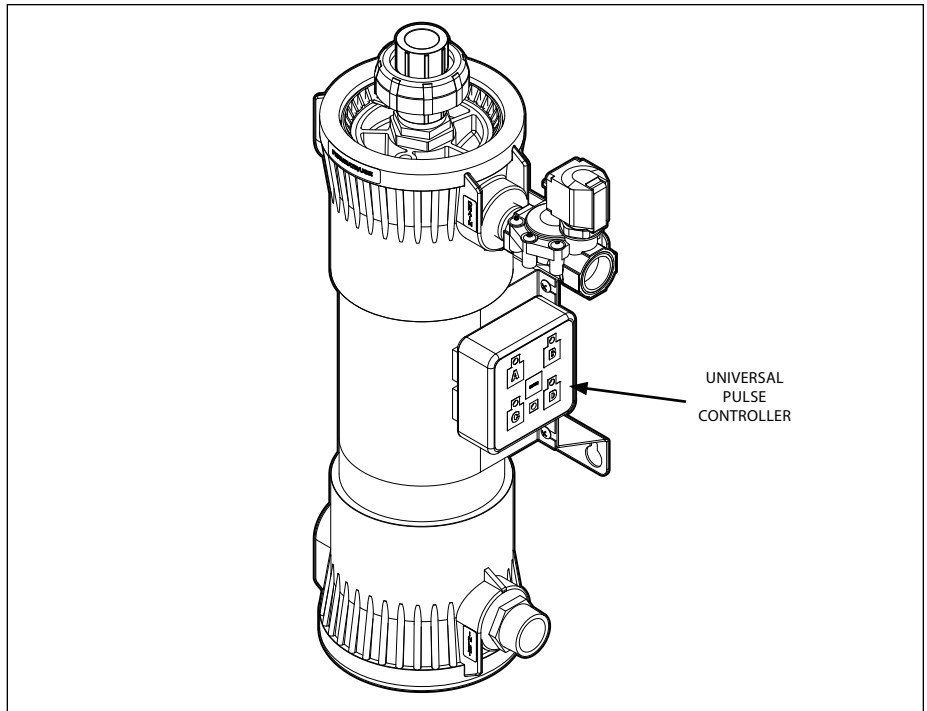

Figure 2. UFL-410 System

INSTALLATION

Unpacking

1. Open the large box. It should contain:
 - a. Filtration System with Ultra Filter Cartridge installed.
 - b. Power Adaptor and Adaptor Plugs
 - c. Owner's Manual
2. Remove all packing materials and protective coverings from the system.
3. Remove the information packet. Fill out and mail the warranty card immediately to prevent any delay in obtaining warranty coverage.

NOTE: If any parts are damaged, contact A.J. Antunes & Co. IMMEDIATELY at 1-800-253-2991 (toll free in the U.S. and Canada) or 1-630-784-1000.

Equipment Setup

General

When placing the system into service, pay attention to the following guidelines:

- Do NOT immerse cord or plug in water.
- Keep cord away from heated surfaces.

Electrical

The line voltage must match the voltage on the specification label. The plug on the power cord must match the appropriate outlet. Do NOT connect the system to a switched electrical outlet.

Plumbing

NOTE: The system must be connected to the COLD water line. Do NOT connect the system to the hot water line.

This system uses the following connections:

Connection	Description
System Inlet	1" NPT
Permeate (Product Water)	1" NPT
Drain	3/4" FNPT

When making a plumbing connection to the system, use a back-up wrench on the supporting plumbing. Always use a quality, approved pipe sealant or thread seal tape on pipe threads. Do NOT allow pipe sealant inside pipes.

Do NOT over tighten the connections. Use plastic fittings when connecting to the plastic connections of the system.

If soldered plumbing is used, do NOT apply heat to, or near, the filtration system. Use union (O-ring seal) connections for ease of installation and future servicing.

Suggested Tools and Supplies for Installation

The following tools and supplies are suggested to help with the installation:

- Screwdriver
- Adjustable Wrenches
- Drill with Bits
- Level
- Tape Measure
- Pipe Dope or Thread Seal Tape
- Two Gallon Bucket
- Fresh, Unscented Liquid Chlorine Bleach
- Pipe Wrenches
- Garden Hose (for rinsing)
- Hose or pipe for drain line

Mounting the System

The system comes with a pre-attached Mounting Bracket. When mounting the system, pay attention to the following guidelines:

- Allow sufficient access for cartridge replacement. The UFL-410 should be mounted with 12 inches to the top or bottom.
- Mount the system near but NOT above an appropriate electrical outlet.
- Mount the system near a drain for flushing operations.
- Mount the system before all consumable water filtration processes.

- Mount the system with the provided Mounting Bracket and hardware capable of supporting 120 lbs. or more.
- Secure the Mounting Bracket into wall studs or with the appropriate heavy duty mounting hardware.

The system is pre-assembled to a Mounting Bracket which has mounting holes across the top and bottom portion to secure system to the wall. Some of the bottom mounting holes may be obscured. Plan your mounting accordingly.

Inlet Water Plumbing

The Inlet water plumbing line should be 1" NPT or larger. A shutoff valve (not supplied) should be installed in the line leading to the system. The valve should be mounted close to the system inlet and sized properly for the inlet plumbing line.

An optional "T" or Cross Fitting with cap or plug can be installed between the Inlet Valve and the System Inlet. This fitting can be used for draining and sanitizing the system and downstream plumbing.

The system should only be connected to the cold water line.

Before connecting the fitting to the System Inlet, the plumbing to the system must be flushed clear of all debris. Hold a bucket at the inlet water line and slowly open the Inlet Water Valve. Allow the pipe to flush until all debris is removed.

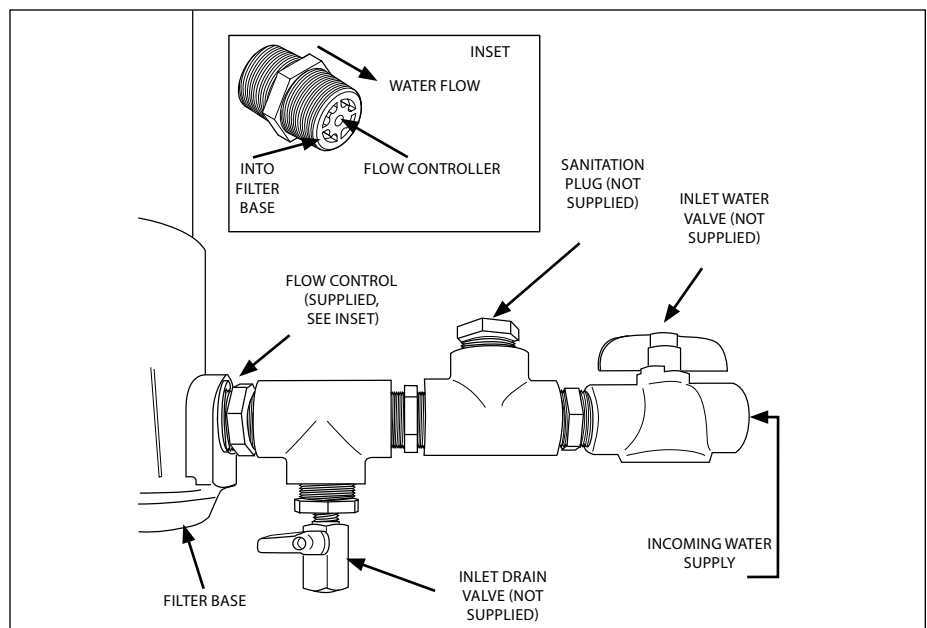

Figure 3. Inlet Water Plumbing

Permeate Line Plumbing

To ensure the highest quality and safest water, it is recommended that a check valve (to prevent back flow) be installed in the water line after the permeate connection. This will help prevent possible contamination of the filter system due to other equipment downstream. The check valve (not supplied) should be mounted close to the system outlet, and sized properly for the plumbing line. Check with local codes for the proper specification.

A shutoff valve (not supplied) should be installed in the filtered water line leading from the system. The valve should be mounted close to the system outlet and sized properly for the plumbing line. This valve will allow for easier servicing and future cartridge replacement.

Drain Valve Connection

The drain hose is for flushing particle buildup out of the system during self cleaning.

1. Cut a length of braided tubing so it reaches the drain from the Drain Valve.
2. Connect one end of the hose to the Drain Valve and secure it with a Worm Clamp (Figure 4).
3. Direct the other end of the hose to the drain.

When connecting the drain hose, pay attention to the following guidelines:

- The drain line plumbing must be able support the flow rate whenever the system flushes. This flow rate is dependent on the inlet water pressure, inlet pipe size, and system.
- The drain line leading out of the system must be as short as possible and slope downwards without any kinks or loops.
- The drain line plumbing must be position and secured at least 2 inches above the drain (Figure 4). This air gap protects the system from contamination in the event of a backed-up drain.
- The drain used must not be blocked or restricted.
- The drain used must be as large or larger than the drain line plumbing.

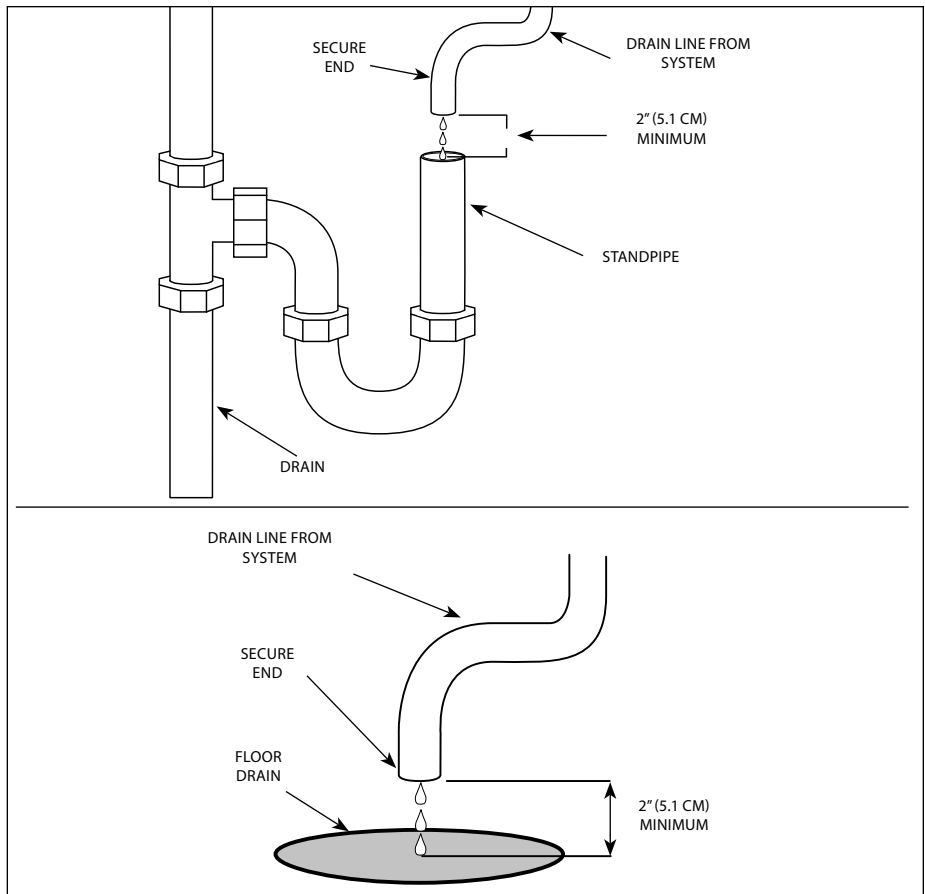

Figure 4. Proper Drain Plumbing

Starting the Controller

1. Select the proper AC plug for your electrical outlet and install it onto the power supply.
2. Plug the appropriate end of the power cord into the controller.
3. Plug the other end of the power cord into the electrical outlet. The LEDs on the controller will light up.
4. The controller automatically enters Flush Mode and the Flush LED starts to flash.
5. When flushing is complete, the Flush LED stops flashing and one or more LEDs will remain lit, indicating the unit has power and which interval is selected in the controller.

Rinsing the Ultra Filter Cartridge

The Ultra Filter Cartridge must be rinsed before the system is used to remove any air and protective solution.

NOTE: Ultra Filter Cartridge must be rinsed to drain before use. Rinsing to drain removes storage solution and air.

1. Direct water from the Permeate Outlet to a drain.

2. Open the tap or faucet closest downstream to the filter system.
3. Slowly open the inlet water valve and allow water to enter the system.
4. Press the FLUSH button. The Drain Valve will open and air and water will come out of the drain line. Repeat six times to ensure all air and storage solution are flushed out of the Ultra Filter Cartridge.
5. Allow water to continue to run through the system and out the faucet for 15 minutes.
6. Inspect the unit for any leaks and repair as needed.
7. After 15 minutes with water flow, close the tap or faucet and let the system stand without water flow for 15 minutes to allow trapped air to come out of the hollow fibers of the Ultra Filter Cartridge.
8. After 15 minutes without water flow, open the tap or faucet for five minutes to flush out the trapped air.
9. Close the tap or faucet.
10. Press the FLUSH button to open the Drain Valve. Repeat six times to ensure any remaining air is flushed out of the system.

Sanitizing the System and Lines

The plumbing must be sanitized to eliminate possible contamination that may have occurred during the installation process.

One ounce (30 ml) of liquid chlorine bleach (regular bleach, unscented 6% sodium hypochlorite) can be used to sanitize the plumbing. The amount of bleach needed depends on the system and the amount of plumbing downstream of the system.

NOTE: Follow the handling and safety instructions supplied with the bleach.

1. Follow the steps in the Rinsing the Ultra Filter Cartridge in the Installation section of this manual.
2. Turn off the water to the system.
3. Open the faucet or tap closest downstream to the system.
4. Close the Inlet Water Valve and allow the system to depressurize.
5. Place a bucket under the "T" or cross fitting at the inlet connection to the system. Open the inlet drain valve or unscrew the cap to drain the system.
6. Press the FLUSH button to help drain the system.
7. When the water flow out of the inlet fitting stops, close the inlet drain valve and pour the liquid bleach into the inlet connection fitting. Be careful not to spill bleach onto clothing or skin. You may want to add the bleach using a cup. Reattach the cap on the fitting.
8. Slowly open the inlet water valve and allow water to flow out of the tap until the smell of bleach is present.
9. Immediately close the tap and let the system stand with no water flow for at least 15 minutes to allow the bleach to sanitize the pipes.
10. After 15 minutes without water flow, open the tap and flush until the presence of bleach is gone. All other taps should be opened to flush any bleach from the plumbing. Close the taps.
11. Press the FLUSH button to complete the flushing process.

IMPORTANT

Commonwealth of Massachusetts Plumbing Code 248 CMR shall be adhered to. The use of saddle valves are not permitted, please consult your local plumber.

CAUTION

Ingesting the protective solution may cause irritation of the gastrointestinal tract, colic, diarrhea, or other similar symptoms

MAINTENANCE

Replacing the Ultra Filter Cartridge

1. Turn off water to the system by closing the inlet valve.
2. Press the FLUSH button to flush the system and relieve pressure. Repeat several times.
3. Place a bucket under the "T" or cross fitting at the inlet connection to the system. Open the valve or unscrew the cap to drain the system.

NOTE: Make sure there is enough room next to the system to remove the cartridge.

4. Close the inlet drain valve or reattach the cap on the "T" fitting when the water flow stops.
5. Unplug the system.
6. Remove the Snap Ring from the Ultra Filter Housing. Grab the raised lug with a pair of pliers and pull towards the center of the End Cap and away. The Snap Ring should lift out of its groove.
7. Remove the End Cap, End Cap O-ring, and Cartridge from the housing (Figure 5).

NOTE: If the Cartridge does not easily come out of the Housing, remove the opposite End Cap for assistance.

8. Inspect the Large End Cap O-rings and End Cap O-ring for nicks or cuts. Replace as needed.
9. Lubricate all O-rings with a food-grade silicone lubricant. Apply a light coating of lubricant to the inside center tube at both ends of the new cartridge.
10. Record the serial number of the new cartridge. The cartridge serial number is engraved on one end of the outer tube (for example: 05K 12013).
11. Install the End Cap O-ring on the End Cap and insert the Large End Cap into the end of the new cartridge.
12. Position the new cartridge and End Cap at the housing and gently insert into the housing.
13. Press the End Cap into position until it is fully seated and the Snap Ring groove is visible.

14. Install the Snap Ring by guiding the non-lugged end into the groove first, pushing outward and working around the ring until it snaps into place.

NOTE: Make sure that the Snap Ring is fully seated before turning the water on.

15. Rinse the new Ultra Filter Cartridge before placing the system back into operation. Follow the Rinsing the Ultra Filter Cartridge and Sanitizing the System and Lines procedures in the Installation section of this manual to complete the cartridge change.

16. When rinsing is complete, repressurize the system.

System Sanitization

The system and downstream plumbing should be sanitized at least every six months. When necessary, follow the procedure in Sanitizing the System and Lines in the Installation section of this manual.

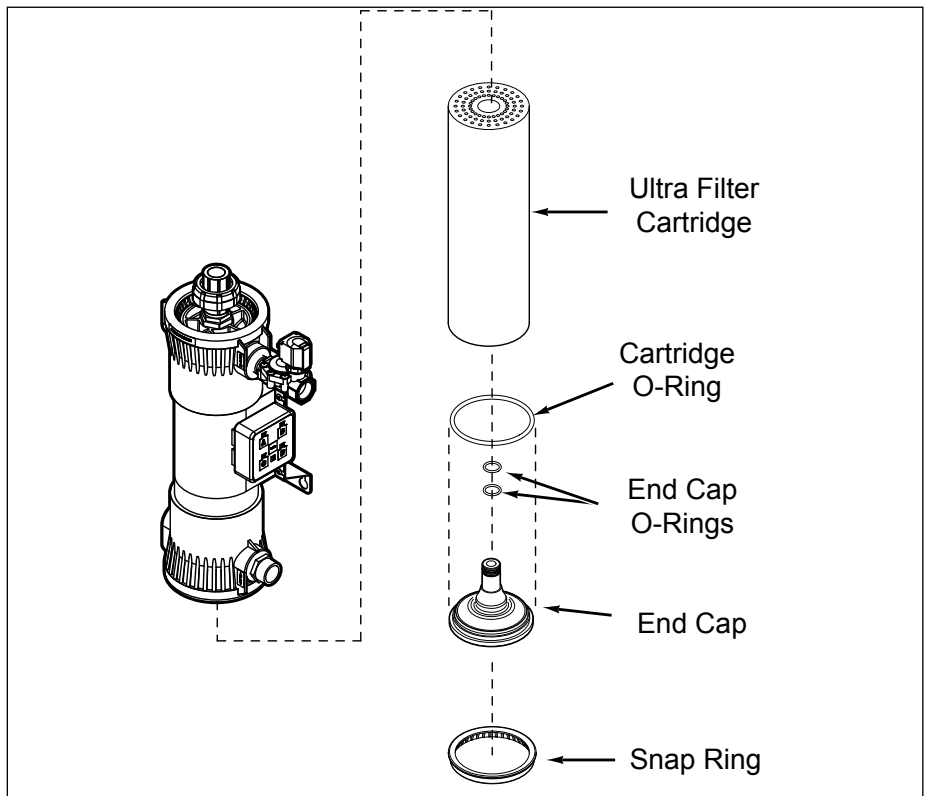

Figure 5. Replacing the Ultra Filter Cartridge

Changing the Interval Setting

CAUTION

Changing the flush interval can cause the Ultra Filter to plug prematurely and may reduce the life of the filter. Consult the factory for more information.

Though not recommended, the Interval Setting on the controller can be changed. If the setting must be changed, use the chart below. Press and hold the corresponding button. After 5 seconds, the Button LED will turn on. After 10 seconds, the Flush LED will also turn on.

Flush Interval	Button	Hold Time (Secs)	Button LED	Flush LED
15 minutes	A	10	On	On
30 minutes	B	10	On	On
45 minutes	C	10	On	On
1 hour	A	5	On	Off
4 hour	B	5	On	Off
6 hours	C	5	On	Off
12 hours	D	5	On	Off
24 hours	D	10 seconds	On	On

Resetting the Timer Program

During the normal operation, the system will flush according to the set interval. It is possible the system will flush at a time of high water use. If this poses a problem, the controller can be reset. Unplug the power supply, wait for 5 seconds, and then plug the power supply in. When power is restored to the controller, it will automatically enter Flush Mode. The controller will then begin timing from the point when power is restored based on the interval setting selected.

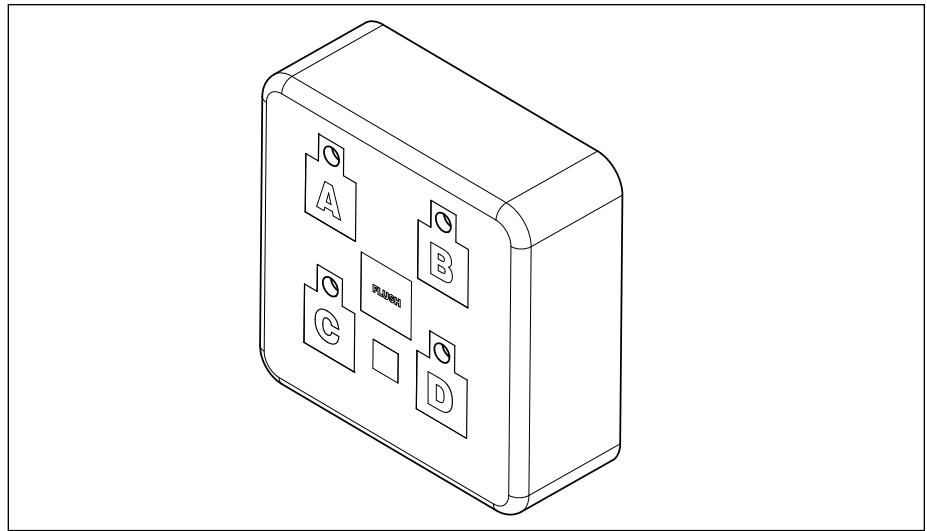
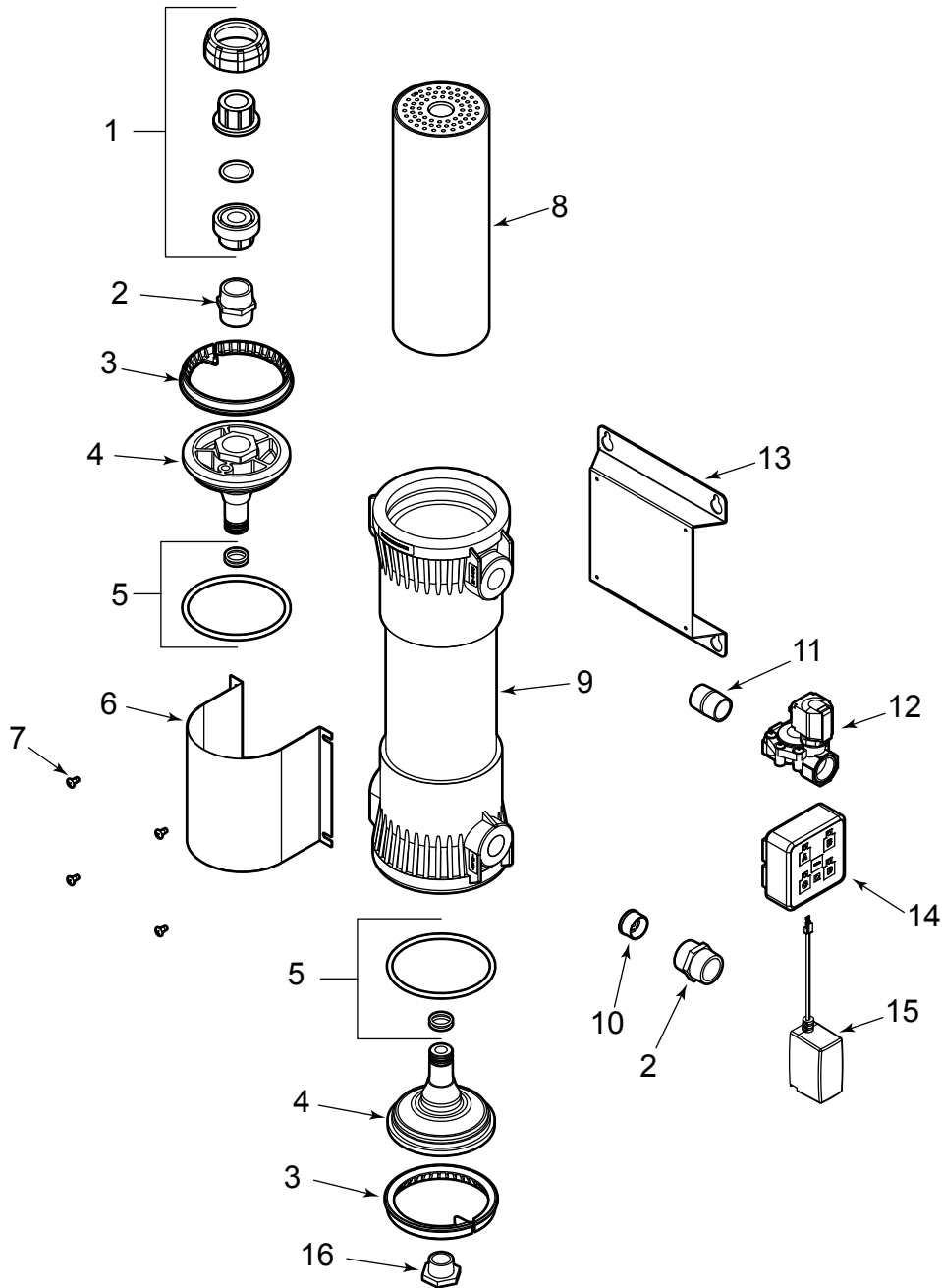

Figure 6. Controller

TROUBLESHOOTING

Problem	Possible Cause	Corrective Action
Unit does not have power.	The power cord is not correctly plugged in.	Plug power cord in correctly.
The Control Display is blank.	The power cord is not correctly plugged in.	Plug power cord in correctly.
	Control Board is inoperable.	Contact your maintenance person or Authorized Service agency.
	Transformer is inoperable.	
No water comes out of the filter system	Inlet Valve closed	Open the Inlet Valve
	Inlet Strainer is plugged	Clean/replace Inlet Strainer
	End of the capillaries plugged	Clean/replace Filter Cartridge
Low water flow/pressure out of system	See above.	See above.
	The system may be in a flush cycle.	Wait for the flush cycle to end.
	Flushing program not set correctly for water conditions.	Decrease the flush interval (refer to the Operation section of this manual).
	Drain Valve is stuck open.	Replace/rebuild the Drain Valve.
	The inlet water pressure is too low.	Boost the inlet water pressure/replace pipes.
Water tastes bad.	Storage/shipping solution not completely rinsed out of system.	Rinse system for a longer period of time.
	Biological growth in pipes.	Sanitize plumbing.
	Water conditions changed.	Consider installing taste and odor filtration.
	Broken capillary in Filter Cartridge.	Replace Filter Cartridge.
Flush runs continuously.	Drain Valve stuck open.	Replace/rebuild the Drain Valve.
	Controller sending continuous signal to valve.	Replace the controller.
Flush occurs at time of high water usage.	The Flush Interval is set to interfere with water use.	Change Flush Interval. Unplug unit and plug in at a time of lower water usage.
Water splashes at drain during flush.	Drain line not positioned properly.	Reposition the end of the drain line.
Water leaks at the ends of the Filter Cartridge after changing cartridges.	Cartridge end connections are not tight enough.	Tighten with wrench if necessary.
	O-rings not lubricated.	Lubricate O-rings with food-grade lubricant.
	O-rings are split, cut, or twisted	Replace O-rings.
Water leaks from Permeate port.	Permeate port is not tight enough	Tighten, with wrench if necessary.
	O-ring not lubricated.	Lubricate O-ring with food-grade lubricant.
	O-ring split, cut, or twisted.	Replace O-ring.
Water leaks from system fitting or connection.	Fitting broken or loose.	Retighten or replace the fitting.
	Not enough pipe thread sealant used.	Redo the fitting with the proper amount of sealant.

Replacement Parts can be purchased from an authorized dealer. Contact A.J. Antunes & Co. at 1-630-754-1000 or toll free in the United States at 1-800-253-2991.



Item	Part #	Description	Qty.
1	2190150	Union Adaptor, 1" NPT	1
2	2190147	Nipple, Hex 1" NPT	2
3	2180181	Ring, Lock	2
4	2180228	Cap, End 1" Port	2
5	7000413	O-Ring Replacement Kit	1
	0200235	O-Ring, End Cap	2
	0800236	O-Ring, Cartridge	4
	2140153	Lubricant, High Vacuum Grease	1

Item	Part #	Description	Qty.
6	0504065	Clamp, 4" Filter	1
7	3080157	Screw, Tap 8-32 x 3/8" LG.	4
8	7000839	Cartridge Replacement Kit UFL-410 (Includes O-Ring Replacement Kit 7000413)	1
9	2180325	Filter Housing, UFL-410	1
10	0021338	Flow Reg. Assy., UFL-410, 5 gpm	1
11	2070117	Nipple, 3/4" NPT	1
12	4040189	Solenoid Valve, NC 3/4" NPT	1

Item	Part #	Description	Qty.
13	0504279	Bracket, Mounting	1
14	0012357	Universal Pulse Controller	1
15	0012146	Power Adapter Assembly	1
16	2190148	Plug, Pipe 1" NPT	1
17*	2140158	Cord, Thread Sealing	1
18	0700769	Wire Harness	1

*not shown

LIMITED WARRANTY

Equipment manufactured by A.J. Antunes & Co. has been constructed of the finest materials available and manufactured to high quality standards. These units are warranted to be free from defects in materials and workmanship for a period of two years from date of purchase under normal use and service, and when installed in accordance with manufacturer's recommendations*. The ultra filtration membrane cartridge is warranted under the same terms and conditions on a prorated basis for 36 months from date of purchase.

*To ensure continued proper operation of the units, follow the maintenance procedure outlined in the Owner's Manual.

1. This warranty does not cover failures due to improper system installation, defects caused by improper storage or handling prior to placing of the equipment into service. This warranty does not include overtime charges or work done by unauthorized service agencies or personnel. This warranty does not cover normal maintenance, calibration, or regular adjustments as specified in operating and maintenance instructions of this manual, and/or labor involved in moving adjacent objects to gain access to the Equipment.
2. A.J. Antunes & Co. reserves the right to make changes in design or add any improvements on any product. The right is always reserved to modify equipment because of factors beyond our control and government regulations. Changes to update equipment do not constitute a warranty charge.
3. **If shipment is damaged in transit, the purchaser should make a claim directly upon the carrier. Careful inspection should be made of the shipment as soon as it arrives and visible damage should be noted upon the carrier's documentation. Damage should be reported to the carrier. This damage is not covered under this warranty.**
4. THIS WARRANTY IS EXCLUSIVE AND IS IN LIEU OF ALL OTHER WARRANTIES, EXPRESSED OR IMPLIED, INCLUDING ANY IMPLIED WARRANTY OR MERCHANTABILITY OR FITNESS FOR A PARTICULAR PURPOSE, EACH OF WHICH IS HEREBY EXPRESSLY DISCLAIMED. THE REMEDIES DESCRIBED ABOVE ARE EXCLUSIVE AND IN NO EVENT SHALL A.J. ANTUNES & CO. BE LIABLE FOR SPECIAL CONSEQUENTIAL OR INCIDENTAL DAMAGES FOR THE BREACH OR DELAY IN PERFORMANCE OF THIS WARRANTY.
5. Prices and specifications are subject to change without notice.



U.S. Headquarters

Carol Stream, Illinois
Phone: (630) 784-1000
Toll Free: (800) 253-2991
Fax: (630) 784-1650

China Facility

Suzhou, China
Phone: 86-512-6841-3637
Toll Free: 86-512-6841-3907
Fax: 400-0-7878-22