

# VCT-20/25/50

## *Vertical Contact Toaster*

## owner's manual

### **Manufacturing Numbers:**

9200560, 9200600, 9200602, 9200606, 9200608,  
9200609, 9200614, 9200616, 9200620, 9200622,  
9200624, 9200625, 9200626, 9200628, 9200629,  
9200630, 9200631, 9200632, 9200634, 9200637,  
9200638, 9200639, 9200640

# VERTICAL CONTACT TOASTER

## TABLE OF CONTENTS

|   |          |   |                   |
|---|----------|---|-------------------|
| <b>Owner Information</b> .....              | <b>2</b> | <b>Operation</b> .....                            | <b>9</b>          |
| General .....                               | 2        | Operating Instructions .....                      | 9                 |
| Warranty Information .....                  | 2        | Safety Features .....                             | 9                 |
| Service/Technical Assistance .....          | 3        | <b>Maintenance</b> .....                          | <b>10</b>         |
| <b>Important Safety Information</b> .....   | <b>3</b> | Daily.....  | 10                |
| <b>Specifications</b> .....                 | <b>5</b> | Conveyor Belt Chains.....                         | 11                |
| Electrical Cord & Plug Configurations ..... | 5        | Replacing Spring Tensioners.....                  | 12                |
| Model Designation.....                      | 5        | Replacing Conveyor Motor and Fan Blade .....      | 12                |
| Electrical Ratings.....                     | 5        | <b>Troubleshooting</b> .....                      | <b>13</b>         |
| Dimensions.....                             | 6        | <b>Wiring Diagram</b> .....                       | <b>19</b>         |
| <b>Installation</b> .....                   | <b>7</b> | <b>Replacement Parts</b> .....                    | <b>20</b>         |
| Unpacking.....                              | 7        | <b>Optional Parts – VCT-25 &amp; VCT-50</b> ..... | <b>25</b>         |
| Assembling the Unit .....                   | 7        | <b>Notes</b> .....                                | <b>26</b>         |
| Equipment Setup .....                       | 8        | <b>Limited Warranty</b> .....                     | <b>Back Cover</b> |

## OWNER INFORMATION

### General

The Vertical Contact Toaster, Models VCT-20, VCT-25 and VCT-50 are designed for contact toasting of buns. The toaster design allows the operator to place buns on both sides of the heated platen at the same time. Buns are placed into the top of the toaster and uniform, golden brown, warm buns are then retrieved at the bottom of the toaster. The Model VCT-20 is equipped with an auxiliary heating system which provides additional heat to the buns.

This manual provides the safety, installation and operating procedures for the Vertical Contact Toaster. We recommend that all information contained in this manual be read prior to installing and operating the unit.

Your Vertical Contact Toaster is manufactured from the finest materials available and is assembled to our strict quality standards. This unit has been tested at the factory to ensure dependable trouble-free operation.

### Warranty Information

Please read the full text of the Limited Warranty in this manual.

If the unit arrives damaged, contact the carrier immediately and file a damage claim with them. Save all packing materials when filing a claim. Freight damage claims are the responsibility of the purchaser and are not covered under warranty.

The warranty does not extend to:

- Damages caused in shipment or damage as result of improper use.
- Installation of electrical service.
- Normal maintenance as outlined in this manual.
- Malfunction resulting from improper maintenance.
- Damage caused by abuse or careless handling.
- Damage from moisture into electrical components
- Damage from tampering with, removal of, or changing any preset control or safety device.

**IMPORTANT!** Keep these instructions for future reference. If the unit changes ownership, be sure this manual accompanies the equipment.

## OWNER INFORMATION (continued)

### Service/Technical Assistance

If you experience any problems with the installation or operation of your unit, contact Antunes Technical Service.

Fill in the information below and have it handy when calling Antunes Technical Service for assistance. The serial number is on the specification plate located on the rear of the unit.

Purchased From: \_\_\_\_\_

Date of Purchase: \_\_\_\_\_

Model No.: \_\_\_\_\_

Serial No.: \_\_\_\_\_

Mfg. No.: \_\_\_\_\_

Use only genuine Antunes replacement parts in this unit. Use of replacement parts other than those supplied by the manufacturer will void the warranty.

You may contact Antunes Technical Service at 1-877-392-7854

## IMPORTANT SAFETY INFORMATION

Throughout this manual, you will find the following safety words and symbols that signify important safety issues with regards to operating or maintaining the equipment.



**WARNING**

**GENERAL WARNING.** Indicates information important to the proper operation of the equipment. Failure to observe may result in damage to the equipment and/or severe bodily injury or death.



**WARNING**

**ELECTRICAL WARNING.** Indicates information relating to possible shock hazard. Failure to observe may result in damage to the equipment and/or severe bodily injury or death.



**CAUTION**

**GENERAL CAUTION.** Indicates information important to the proper operation of the equipment. Failure to observe may result in damage to the equipment.



**WARNING**

**HOT SURFACE WARNING.** Indicates information important to the handling of equipment and parts. Failure to observe caution could result in personal injury.

A.J. Antunes & Co. reserves the right to change specifications and product design without notice. Such revisions do not entitle the buyer to corresponding changes, improvements, additions or replacements for previously purchased equipment.

# VERTICAL CONTACT TOASTER

## IMPORTANT SAFETY INFORMATION (continued)

In addition to the warnings and cautions in this manual, use the following guidelines for safe operation of the unit.

- Read all instructions before using equipment.
- For your safety, the equipment is furnished with a properly grounded cord connector. Do not attempt to defeat the grounded connector.
- Install or locate the equipment only for its intended use as described in this manual. Do not use corrosive chemicals in this equipment.
- Do not operate this equipment if it has a damaged cord or plug, if it is not working properly, or if it has been damaged or dropped.
- This equipment should be serviced by qualified personnel only. Contact Antunes Technical Service for adjustment or repair.
- Do not block or cover any openings on the unit.
- Do not immerse cord or plug in water.
- Keep cord away from heated surfaces.
- Do not allow cord to hang over edge of table or counter.

The following warnings and cautions appear throughout this manual and should be carefully observed.

- Turn the unit off, disconnect the power source and allow unit to cool down before performing any service or maintenance on the unit.
- The procedures in this chapter may include the use of chemical products. These chemical products will be highlighted with bold face letters followed by the abbreviated HCS (Hazard Communication Standard). See Hazard Communication Standard manual for the appropriate Material Safety Data Sheets (MSDS).

- The toaster should be grounded according to local electrical codes to prevent the possibility of electrical shock. It requires a grounded receptacle with separate electrical lines, protected by fuses or circuit breaker of the proper rating.
- Bread may burn. Therefore toasters must not be used near or below curtains or other combustible walls and materials. Failure to maintain safe operating distances may cause discoloration or combustion.
- Failure to use release sheets may result in damage to the equipment and loss of warranty coverage.
- All electrical connections must be in accordance with local electrical codes and any other applicable codes.
- **WARNING ELECTRICAL SHOCK HAZARD. FAILURE TO FOLLOW THESE INSTRUCTIONS COULD RESULT IN SERIOUS INJURY OR DEATH.**
  - Electrical ground is required on this appliance.
  - Do not modify the power supply cord plug. If it does not fit the outlet, have a proper outlet installed by a qualified electrician.
  - Do not use an extension cord with this appliance.
  - Check with a qualified electrician if you are in doubt as to whether the appliance is properly grounded.

# VERTICAL CONTACT TOASTER

## SPECIFICATIONS

### Electrical Ratings and Plug Configurations

| Model & Mfg. No.  | Volts   | Watts         | Amps      | Hz    | Plug Description  |  |
|-------------------|---------|---------------|-----------|-------|---|--|
| VCT-50<br>9200609 | 208-240 | 2600-<br>3460 | 12.5-14.4 | 50/60 | IEC-309,<br>16 Amp., 250 VAC<br>Pin & Sleeve<br>(Assembly Only) |  |
| VCT-25<br>9200637 | 208-240 | 2600-<br>3460 | 12.5-14.4 | 50/60 |   |  |
| VCT-50<br>9200602 | 120     | 1760          | 14.7      | 60    | 5-20P,<br>20 Amp., 120 VAC<br>Non-Locking<br>(Assembly Only)    |  |
| VCT-25<br>9200622 | 120     | 1760          | 14.7      | 60    |   |  |
| VCT-50<br>9200606 | 208-240 | 2600-<br>3460 | 12.5-14.4 | 50/60 | 6-20P,<br>20 Amp., 250 VAC<br>Non-Locking<br>(Assembly Only)    |  |
| VCT-50<br>9200614 | 208-240 | 2600-<br>3460 | 12.5-14.4 | 50/60 |   |  |
| VCT-25<br>9200626 | 208-240 | 2600-<br>3460 | 12.5-14.4 | 50/60 |   |  |
| VCT-25<br>9200632 | 208-240 | 2600-<br>3460 | 12.5-14.4 | 50/60 |   |  |
| VCT-50<br>9200608 | 208-240 | 2600-<br>3460 | 12.5-14.4 | 50/60 | CEE 7/7,<br>16 Amp., 250 VAC<br>(Assembly Only)                 |  |
| VCT-50<br>9200616 | 208-240 | 2600-<br>3460 | 12.5-14.4 | 50/60 |   |  |
| VCT-25<br>9200625 | 208-240 | 2600-<br>3460 | 12.5-14.4 | 50/60 |   |  |
| VCT-25<br>9200628 | 208-240 | 2600-<br>3460 | 12.5-14.4 | 50/60 |   |  |
| VCT-25<br>9200629 | 208-240 | 2600-<br>3460 | 12.5-14.4 | 50/60 |   |  |
| VCT-25<br>9200634 | 208-240 | 2600-<br>3460 | 12.5-14.4 | 50/60 |   |  |
| VCT-25<br>9200639 | 230     | 3460          | 15        | 50/60 |   |  |
| VCT-25<br>9200640 | 230     | 2450          | 10.6      | 50/60 |   |  |
| VCT-50<br>9200600 | 120     | 1760          | 14.7      | 60    |   | 5-15P,<br>15 Amp., 120 VAC<br>Non-Locking<br>(Assembly Only) |
| VCT-25<br>9200620 | 120     | 1760          | 14.7      | 60    |   |  |
| VCT-25<br>9200624 | 120     | 1760          | 14.7      | 60    |   |  |
| VCT-25<br>9200630 | 120     | 1760          | 14.7      | 60    |   |  |
| VCT-25<br>9200631 | 208-240 | 2600-<br>3460 | 12.5-14.4 | 50/60 |   |  |
| VCT-25<br>9200638 | 208-240 | 2600-<br>3460 | 12.5-14.4 | 50/60 |   |  |
| VCT-20<br>9200560 | 280-240 | 3200-<br>4257 | 15.4-17.3 | 50/60 | LS-30P,<br>30 Amp., 120 VAC<br>Straight Twist Lock              |  |

# VERTICAL CONTACT TOASTER

## SPECIFICATIONS (continued)

### Dimensions

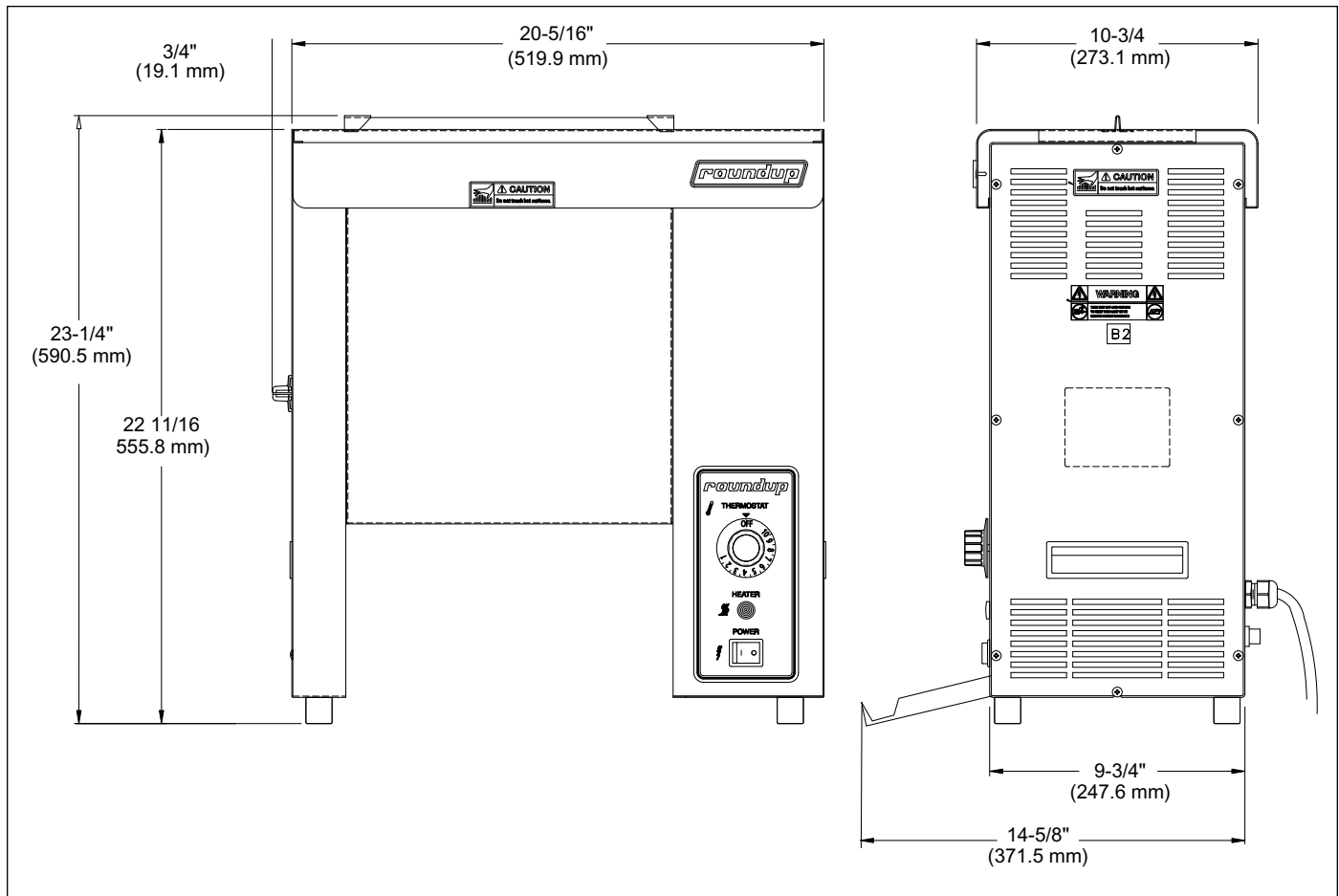

## INSTALLATION

### Unpacking

1. Remove unit and all packing materials from shipping carton.
2. Open the large box. It should contain:
  - Bun chute (Figure 2)
  - Plastic bag containing the release sheet (Figure 4)
3. Remove all packing materials and protective coverings from the unit and parts.

**NOTE: If any parts are missing or damaged, contact Antunes Technical Service IMMEDIATELY at 1-877-7854-392.**

### Assembling the Unit

1. Remove the Heat Shield and the front and rear Conveyor Covers (Figure 1).
2. Install the Damper Assembly. (Figure 1).

**NOTE: Make sure the damper assy. rests only on the bottom front and rear yellow support rods.**

3. Install the Bun Chute (Figure 2).
4. Remove the Release Sheet from the plastic bag and lay it on a clean, flat surface. Fold the sheet exactly in half (Figure 3).
5. Crease the sheet at the fold using only your finger (Figure 3).

**NOTE: Do not use metal tools to crease the sheet.**

6. Install the Release Sheet by draping it over both sides of the Platen surface. The crease should be centered directly on top of the Platen (Figure 4).

#### ⚠ CAUTION ⚠

**Failure to use release sheets may result in damage to the unit and loss of warranty coverage.**

7. Re-install the front and rear Conveyor Covers (Figure 4).

**IMPORTANT: Make sure the Conveyor Covers rest only on both the top and bottom yellow support rods.**

8. Install the Heat Shield so that the clips fit over the top of the Platen and retains the Release Sheet in place (Figure 4).

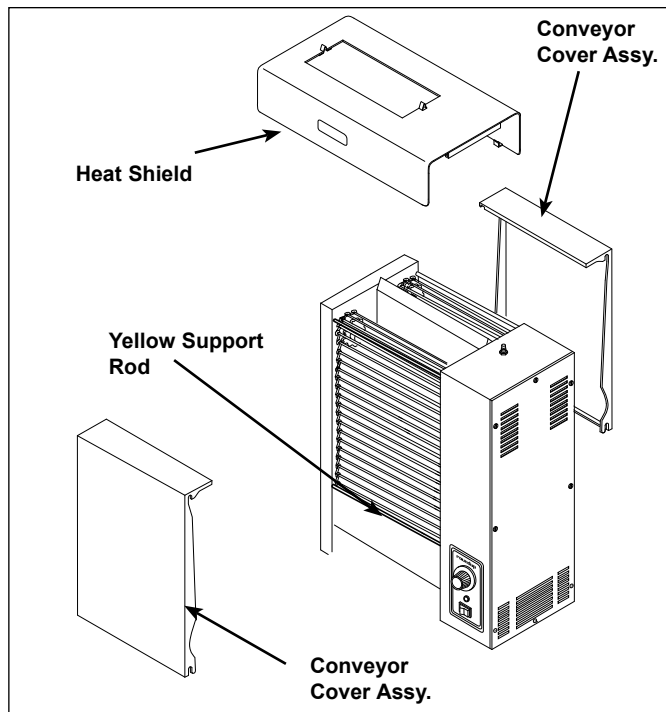

Figure 1. Installing Damper Assy.

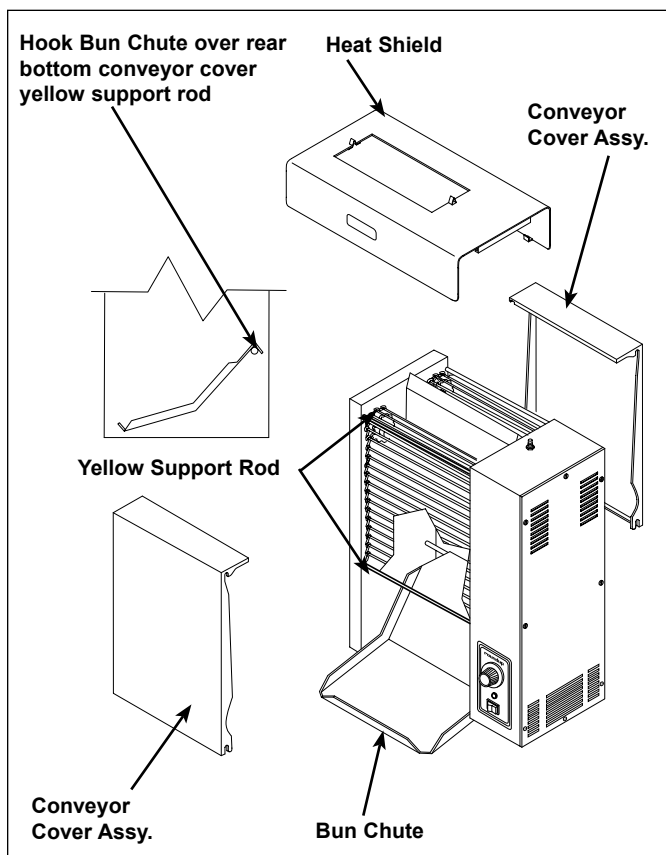

Figure 2. Installing Bun Chute

# VERTICAL CONTACT TOASTER

## INSTALLATION (continued)

**IMPORTANT:** Make sure Heat Shield is activating the conveyor interlock switch (see Figure 4). The conveyors will not rotate unless the heat shield is in place and interlock switch is activated (depressed).

**NOTE:** Check the release sheet to make sure it is not caught in the conveyor. Additional release sheets can be obtained through your authorized service agency under part no. 7000249 (3 pack) or 7000250 (10 pack).

### Equipment Setup

When placing the toaster into service, pay attention to the following guidelines.

- Make sure power to the unit is off and the toaster is at room temperature.
- Do not block or cover any openings on the unit.
- Do not immerse cord or plug in water.
- Keep cord away from heated surfaces.
- Do not allow cord to hang over edge of table or counter.

Connect the unit to the power supply. Refer to the specification plate for the proper voltage.

#### ⚠ WARNING ⚠

**ELECTRICAL SHOCK HAZARD. FAILURE TO FOLLOW THE INSTRUCTIONS IN THIS MANUAL COULD RESULT IN SERIOUS INJURY OR DEATH.**

- Electrical ground is required on this appliance.
- Do not modify the power supply cord plug. If it does not fit the outlet, have a proper outlet installed by a qualified electrician.
- Do not use an extension cord with this appliance.
- The toaster should be grounded according to local electrical codes to prevent the possibility of electrical shock. It requires a grounded receptacle with separate electrical lines, protected by fuses or circuit breaker of the proper rating.
- Check with a qualified electrician if you are in doubt as to whether the appliance is properly grounded.

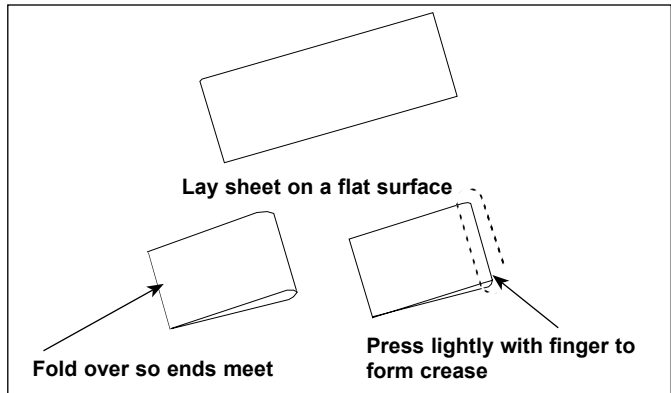

Figure 3. Folding Release Sheet

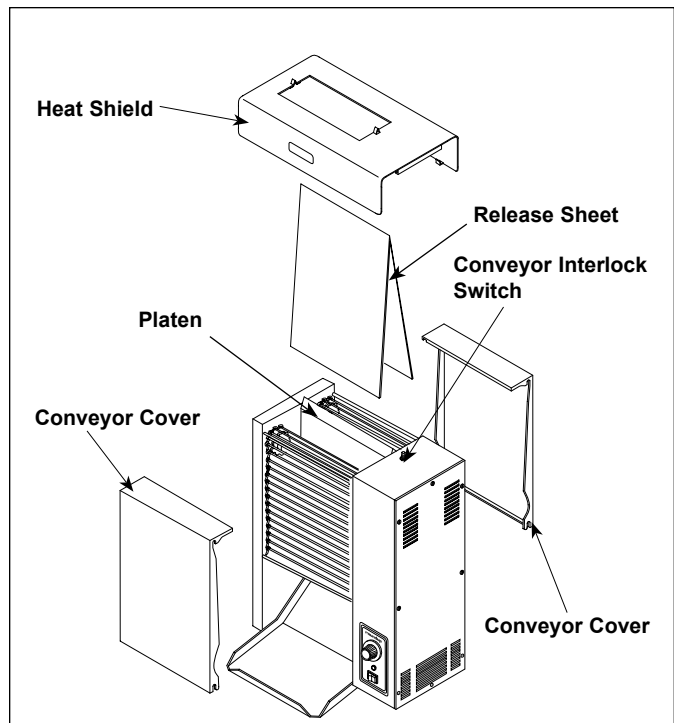

Figure 4. Installing Release Sheet

#### ⚠ CAUTION ⚠

**All electrical connections must be in accordance with local electrical codes and any other applicable codes.**

#### ⚠ CAUTION ⚠

**Bread may burn. Therefore toasters must not be used near or below curtains or other combustible walls and materials. Failure to maintain safe operating distances may cause discoloration or combustion.**



## OPERATION

### Operating Instructions

1. Set the Bun Thickness Adjustment Control knobs to the desired settings (Figure 6). The recommended setting is 6.

**NOTE: After initial run of 4-6 buns, adjust controls according to the desired finished product.**

2. Turn the Rocker Switch (power On/Off) to ON (Figure 5).
3. Turn the Temperature Control to 10. Allow 30 minutes warm-up time before proceeding.
4. Drop buns into toaster with the cut sides of heel and crown facing each other (Figure 5).
5. Toasted product will drop into the Bun Landing Area (Figure 5).
6. Test at least 4 buns before putting toaster into service. Turn the Temperature Control to a lower setting for lighter toasting or to a higher setting for darker toasting.
7. Turn the unit off when finished toasting.

### Safety Features

#### HI-LIMIT RESET BUTTON

A hi-limit thermostat will turn off electrical power to the heater and control circuits if the unit overheats. To reset this thermostat, allow sufficient time (10-15 minutes) for the unit to cool down, then press and release reset button located at the rear of the unit (Figure 5).

If the unit requires continuous resetting, contact your Authorized Service Agency.

#### CONVEYOR INTERLOCK SAFETY SWITCH

A Conveyor Interlock Safety Switch is located on top of the unit under the Heat Shield (Figure 4). The conveyors will not rotate unless the Heat Shield is properly in place and activating the Conveyor Interlock Safety Switch.

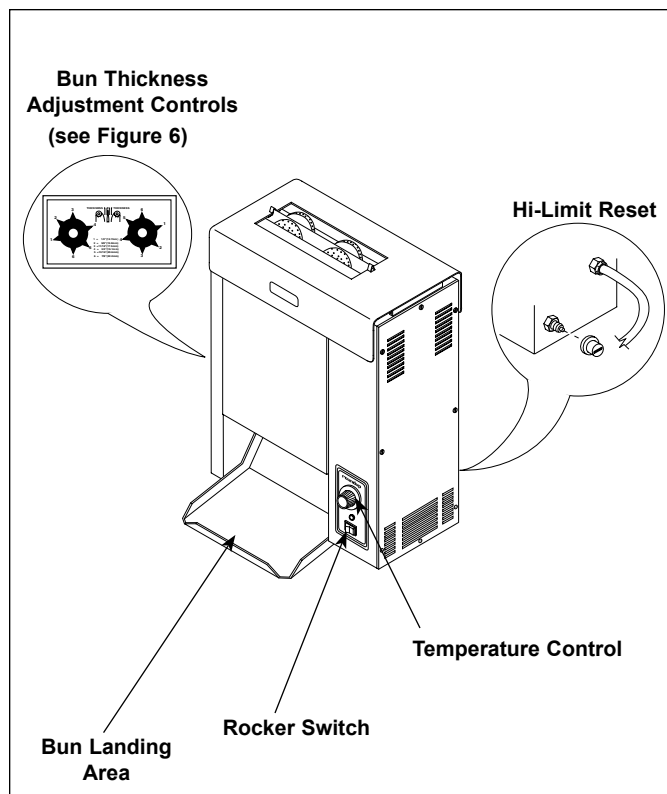

Figure 5. Toaster Controls

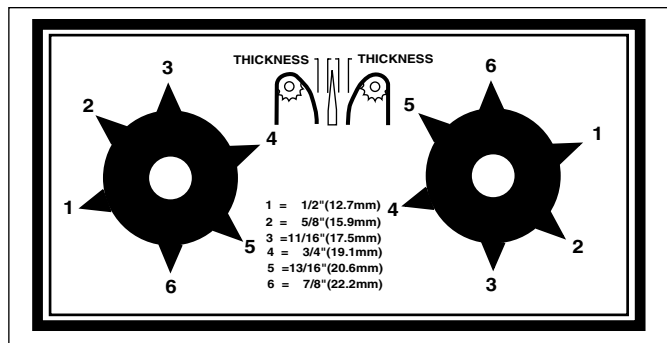

Figure 6. Bun Thickness Adjustment Controls

# VERTICAL CONTACT TOASTER

## MAINTENANCE

### ⚠ WARNING ⚠

Turn the unit off, disconnect the power source and allow the unit to cool down before performing any service or maintenance on the unit.

### Daily

#### CLEANING THE ACCESSORIES

1. Turn the unit off, unplug the power cord, and allow the unit to cool for 30 minutes.
2. Remove the Heat Shield and Bun Chute. Wash these items in soapy water, rinse with clear water, sanitize, and allow to air dry.
3. Wipe down the outside of the toaster with a slightly damp cloth and allow to air dry.

#### CLEANING THE RELEASE SHEET

1. Make sure the unit is turned off, the power cord is unplugged, and the unit is cool. Put on heat resistant gloves. Remove the Release Sheet (Figure 7).
2. Lay the Release Sheet on a clean, flat, dry surface. Apply an appropriate cleanser to a clean, dry towel.
3. Wipe the towel firmly across the Release sheet from top to bottom over its entire surface. Repeat this procedure with a clean, dry towel dampened with water.
4. Next, wipe the Release Sheet with a clean towel dampened with sanitizer and allow to air dry. Repeat Steps 3 through 4 on the reverse side of the Release Sheet.
5. Remove the front and rear Conveyor Covers (Figure 4). Wipe the exterior of Conveyor Belt chains with a clean, sanitized towel.
6. Install front and rear Conveyor Covers (Figure 4) and turn the unit on. Count to 10, then turn toaster off. Remove the front and rear Conveyor Covers again and wipe newly exposed section of the Conveyor Belt chains. Re-install the front and rear Conveyor Covers.
7. Install the Release Sheet by draping it over both sides of the Platen with the crease centered directly on the Platen (Figure 7).
8. Install the Heat Shield (Figure 7). The Heat Shield clips fit over the tip of the Platen and retain the Release Sheet in place.

### ⚠ CAUTION ⚠

To prevent damage to the unit, do not use abrasive cleaners on the release sheet.

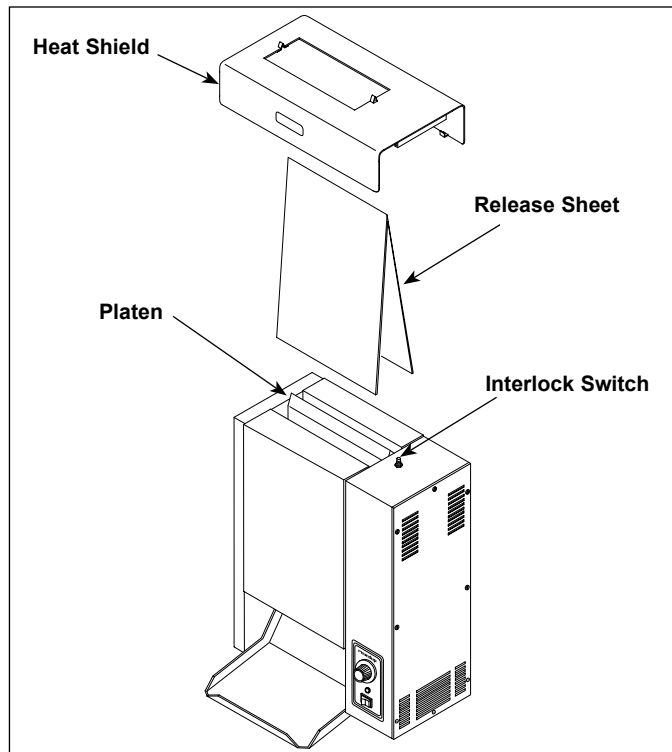

Figure 7. Removing/Installing the Release Sheet

**IMPORTANT:** Make sure the Heat Shield is activating the Conveyor Interlock Safety Switch (see Figure 7). The conveyors will not rotate unless the Heat Shield is in place and Conveyor Interlock Safety Switch is activated.

**NOTE:** Check the Release Sheet to make sure it is not caught in the Conveyor Belt Chain. Additional Release Sheets can be obtained through your Authorized Service Agency under part no. 7000249 (3 pack) or 7000250 (10 pack).

## MAINTENANCE (continued)

### Conveyor Belt Chains

#### MEASURING THE CONVEYOR BELT CHAINS

1. Facing the toaster, locate the approximate center-point of the Conveyor Chain.
2. Pull the Conveyor chain away from the edge of the toaster. Stand a U.S. Dime, 11/16" (1.8 cm) coin on end between the frame and the chain.

If the gap is significantly wider than the coin, REMOVE links as described in the section titled **Adjusting The Conveyor Belt Chains**. Then, measure the gap again to make sure it is not too tight.

Check the opposite side of the toaster using the same measurements.

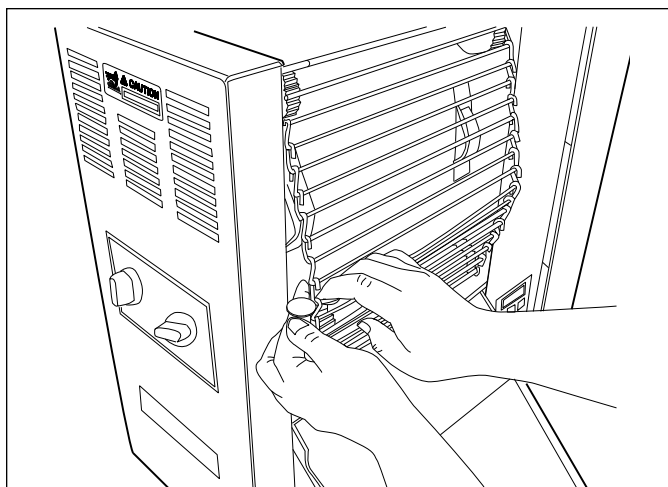

Figure 8. Measuring Conveyor Belt Chains

#### ADJUSTING THE CONVEYOR BELT CHAINS

After a period of time, the conveyor belt links will wear and the conveyor belt will stretch. This will eventually cause the conveyor to jam as it rotates on the sprockets. This is easily remedied by removing one or more conveyor links from each side of the belt.

There are four 1/2" pitch links on each conveyor belt. The rest of the links are 3/4".

1. Remove the Conveyor Belt Chain as described in the section titled **Removing the Conveyor Belt Chains**.
2. To shorten a stretched Conveyor Belt chain, remove one 1/2" link from the belt.
3. Reassemble the Conveyor Belt Chain to the sprockets as described in the section titled **Replacing the Conveyor Belt Chains**.

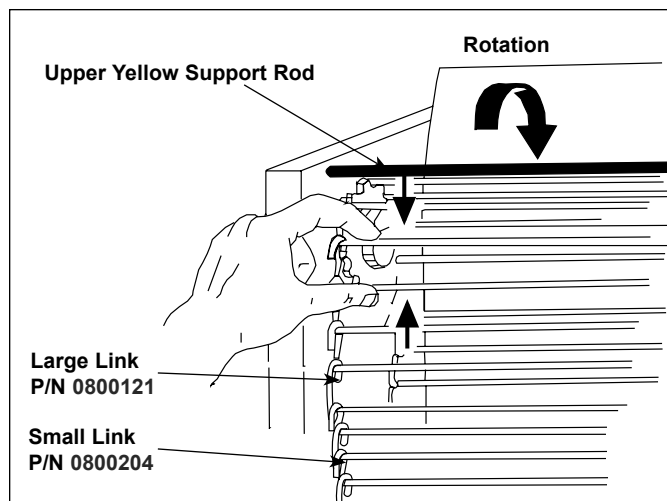

Figure 9. Removing Conveyor Belt Chain

**NOTE:** If the belt is too short (tight) to be reassembled, remove an additional 1/2" link and install a 3/4" link. This will make the conveyor belt 1/4" shorter and enable it to be reassembled.

**IMPORTANT:** This is not covered under warranty. It is a user responsibility.

#### REMOVING THE CONVEYOR BELT CHAINS

1. Turn the unit off, unplug the power cord, and allow the unit to cool down.
2. Remove the Heat Shield, front and rear Conveyor Covers, and Release Sheet (Figure 4).

**NOTE:** When replacing the Conveyor Belt chain, be sure to clean the Release Sheet as well.

3. Set the Bun Thickness Compression Control knobs to 6.
4. Disconnect the Conveyor Belt chain by squeezing any two links together and unhooking both ends of one link (Figure 8). A needle-nose pliers may be required. Remove the Conveyor Belt chain.

**NOTE:** With conveyor belt removed, the tensioner assemblies (4, page 24) and slide rails (40, page 24) can be replaced.

# VERTICAL CONTACT TOASTER

## MAINTENANCE (continued)

### REPLACING CONVEYOR BELT CHAINS

1. Remove the old Conveyor Belt chain as described previously on page 10.
2. Place the replacement Conveyor Belt Chain on the top sprockets. Check for correct positioning (Figure 8).

**NOTE: Install conveyor belt so that the ends of the hooks are facing down.**

3. Wrap the Conveyor Belt chain around the lower sprockets and hook both ends of the Conveyor Belt chain together. A needle-nose pliers may be required.
4. Reinstall the front and rear Conveyor Covers, Release Sheet and Heat Shield.

### Replacing Spring Tensioners

1. Remove acorn nuts (Figure 9).
2. Remove the old Spring Tensioner Assembly.
3. Replace the Tensioner Assembly and reassemble.
4. Make sure the spacers are placed inside the tensioner arm. The spacers are smaller than the holes to allow the tensioner to pivot freely.

### Replacing Conveyor Motor and Fan Blade

**NOTE: A small amount of Loctite (Blue & Red) is required for proper gear motor installation.**

1. Remove control cover.
2. Disconnect the motor wires and remove the drive motor and drive motor bracket (Figure 10). Discard the 8-32 x 5/16" mounting bracket screws.
3. Remove the motor sprocket using a hex wrench.
4. Remove the drive motor bracket from the gear motor. Save the four 10-32 x 3/8" pan head screws (P/N 310P154).
5. Place one drop of Loctite (Blue) into each threaded hole in the gear reducer casting. Attach the drive motor bracket to the gear reducer using the original four 10-32 x 3/8" screws (310P154) removed in step 3.
6. Attach the motor sprocket to the gear reducer as shown in Figure 10.

**NOTE: Be sure sprocket setscrew is positioned on the flat of the gear reducer shaft. Maintain the 3/16" dimension as shown in Figure 11. Apply Loctite (Blue) to threads of setscrew and tighten securely.**

7. Using the four new 8-32 x 5/16" stainless steel SEMS truss head screws (P/N 308P151), attach the drive motor bracket to the mounting bracket. DO NOT tighten screws at this time.
8. Place the drive chain on the sprocket and push down on motor. Allow 1/4" (0.6 mm) play at middle of drive chain, then tighten mounting screws while holding motor. Check drive chain play after tightening screws.
9. Re-connect motor wires, one at a time.
10. Re-install control cover.

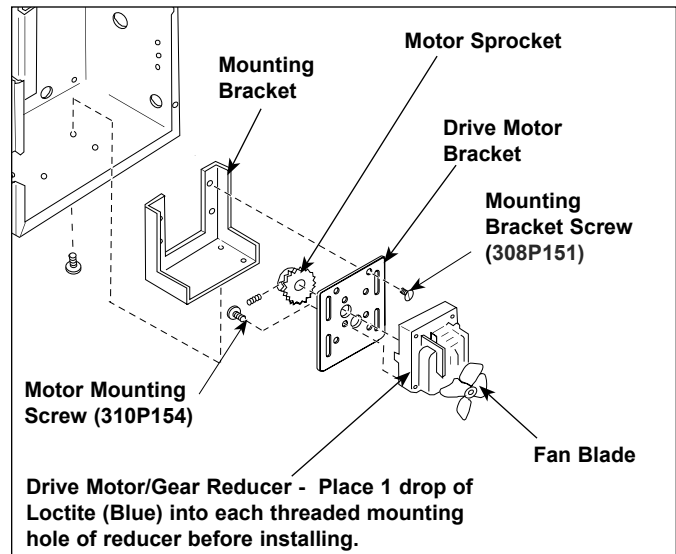

Figure 10. Replacing Drive Motor and Fan Blade

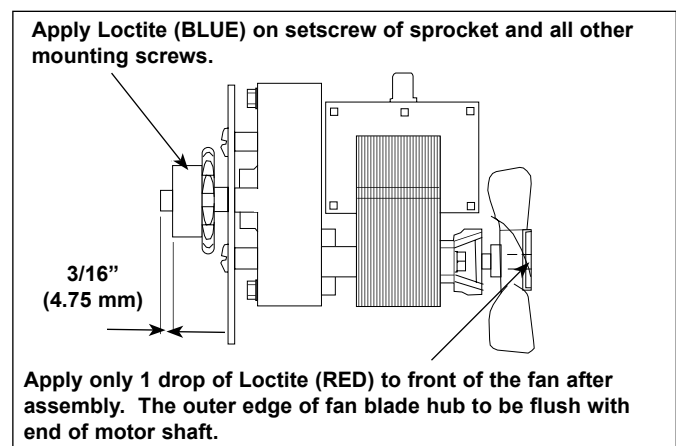

Figure 11. Replacing Drive Motor and Fan Blade

# VERTICAL CONTACT TOASTER

## TROUBLESHOOTING

### ▲ WARNING ▲

To avoid possible personal injury and/or damage to the unit, inspection, test and repair of electrical equipment should be performed by qualified service personnel. The unit should be unplugged when servicing, except when electrical tests are required. Use extreme care during electrical circuit tests. Live circuits will be exposed.

| Problem                                 | Possible Cause   | Corrective Action   |
|---|--|---|
| No heat and conveyor belts do not move. | Toaster is installed incorrectly.                                  | Perform the installation and operating procedures found in the Installation section of this manual.   |
|   | Not enough voltage, defective power cord, defective rocker switch. | Check receptacle for correct voltage. See Specifications (page 5).<br><br>With unit plugged in and rocker switch on, check for correct voltage into rocker switch. If low or zero voltage, replace power cord. If voltage is correct, check for correct voltage out of rocker switch. If low or no voltage, replace rocker switch.  |
|   | Hi-limit switch tripped open.                                      | Reset hi-limit switch (Fig. 5, page 9).   |
|   | Wiring problem.  | Check all electrical connections for burns, discoloration or arcing. Replace all connections or components with damaged terminals. Replace all damaged wiring with the same (or higher) rated wire.   |
| No heat and conveyor belts move.        | Wiring problem.  | Check all electrical connections for burns, discoloration or arcing. Replace all connections or components with damaged terminals. Replace all damaged wiring with the same (or higher) rated wire.   |
|   | Inoperative platen.  | To check platen:<br><br>Use an Ohm meter to test resistance of the platen heater (disconnect 1 wire to isolate heater). Correct cold resistance for heating element of platen are as follows:<br>120 Volts, 1750 Watts - 7.8 Ohms<br>208 Volts, 2550 Watts - 16.2 Ohms<br>230 Volts, 1900 Watts - 26.5 Ohms<br><br>VCT-20 only. The auxiliary heaters are 144.2 Ohms at 208V/300 Watts. |

# VERTICAL CONTACT TOASTER

## TROUBLESHOOTING (continued)

| Problem  | Possible Cause   | Corrective Action   |
|--|--|---|
| Platen is hot and the Conveyor Belt chains are not rotating. | Toaster is installed incorrectly.  | Refer to the Installation and Operation sections of this manual for proper installation and operating procedures.   |
|  | Wiring problems.   | Check all electrical connections for burns, discoloration or arcing. Replace all connections or components with damaged terminals. Replace all damaged wiring with the same (or higher) rated wire.   |
|  | Drive motor inoperable or incorrect conveyor drive motor.  | To check drive motor: <ol style="list-style-type: none"> <li>1. Measure resistance of motor coil. Replace motor if coil measures either open circuit or zero resistance.</li> <li>2. Mark the drive motor sprocket and count the turns per minute. Correct drive motor speed is nine (9) turns per minute for VCT-20; three (3) turns per minute for VCT-25; one (1) turn per minute for VCT-50.</li> </ol> |
|  | Broken Drive Chain or loose sprocket.  | Check the Drive Chain for kinks, broken or bent links, or other damage. Check the motor sprocket and drive sprockets (on drive shaft); tighten setscrew on flat of shaft if required. Check for damaged/worn sprockets and replace as required.   |
|  | Heat Shield not installed or installed incorrectly.  | Install the Heat Shield so that it activates the Conveyor Interlock Safety Switch.  |
|  | Conveyor Belt chains installed incorrectly.  | Install the Conveyor Belt chains according to the Maintenance Section of this manual. Be sure that ends of the hooks are facing down.   |
|  | Conveyor Interlock Safety Switch is not activated.   | Install the Heat Shield so that it activates the Conveyor Interlock Safety Switch.  |
|  | Spring Tensioner Assembly or Tensioner bent or missing.  | Replace the Spring Tensioner assembly(s) (item 29, page 22) or Tensioners (item 4, page 24) if damaged or loose. Replace the Slide Rails (item 40, page 24) if worn or missing.   |
|  | Conveyor Belt chains too loose or missing links (41 links required when new). When new, conveyor has 37 large links and 4 small links. | Adjust or replace the Conveyor Belt chains according to the Maintenance section of this manual.   |

# VERTICAL CONTACT TOASTER

## TROUBLESHOOTING (continued)

| Problem   | Possible Cause   | Corrective Action   |
|---|--|---|
| Product is over-toasted, Platen heat is too high, or drop time is too slow  | Temperature set too high.  | Set temperature control at a lower setting.   |
|   | Bun Thickness Adjustment Control knobs set incorrectly.  | Measure bun thickness and set bun adjustment controls correctly (Fig. 6, page 9).   |
|   | Buns sticking on Release Sheet.  | Clean or replace the Release Sheet or conveyor belt wrap.   |
|   | Conveyor Covers not installed.   | Install the Conveyor Covers.  |
|   | Conveyor Belts chains installed incorrectly  | Install conveyor belt to match diagram in Fig. 8 (page 11). Be sure that ends of the hooks are facing down.   |
|   | Defective Platen.  | To check platen:<br><br>Use an Ohm meter to test resistance of the platen heater (disconnect 1 wire to isolate heater). Correct cold resistance for heating element of platen are as follows:<br>120 Volts, 1750 Watts - 7.8 Ohms<br>208 Volts, 2550 Watts - 16.2 Ohms<br>230 Volts, 1900 Watts - 26.5 Ohms<br><br>VCT-20 only. The auxiliary heaters are 144.2 Ohms at 208V/300 Watts. |
|   | Defective or wrong drive motor.  | To check drive motor:<br><br>1. Measure resistance of motor coil. Replace motor if coil measures either open circuit or zero resistance.<br><br>2. Mark the drive motor sprocket and count the turns per minute. Correct drive motor speed is nine (9) turns per minute for VCT-20; three (3) turns per minute for VCT-25; one (1) turn per minute for VCT-50.                          |
|   | Defective Drive Chain or loose sprocket.   | Check drive chain for kinks, broken or bent links or other damage. Check motor sprocket and drive sprockets (on drive shaft); tighten setscrew on flat of shaft if required. Check for damaged/worn sprockets and replace as required.  |
| Wiring problem.   | Check all electrical connections for burns, discoloration or arcing. Replace all connections or components with damaged terminals. Replace all damaged wiring with the same (or higher) rated wire.                                    |   |
| Conveyor belt too loose or missing links (41 links required when new). When new, conveyor has 37 large links and 4 small links. | Remove conveyor belt (page 11). Lay belt flat and count links. Replace entire belt if links are damaged. If conveyor belt has too much play, it will jam. Adjust belt length as described under Servicing the Conveyor Belt (page 10). |   |

# VERTICAL CONTACT TOASTER

## TROUBLESHOOTING(continued)

| Problem  | Possible Cause   | Corrective Action  |
|--|--|--|
| Product is over-toasted or platen heat is too high or drop time is too slow.<br>(continued). | Spring tensioner assy(s). or tensioner bent or missing.                            | Replace spring tensioner assy(s). (29, page 20) or tensioners (4, page 24) if damaged or loose. Replace slide rails (40, page 24) if worn or missing.  |
|  | Bun adjustment controls set incorrectly.   | Measure bun thickness and set bun adjustment controls correctly (page 9).  |
| Product is under toasted or platen heat is too low or drop time is too fast.                 | Not enough voltage, defective power cord, defective rocker switch.                 | Confirm platen temperature reading with a pyrometer or other temperature source.<br><br>Check receptacle for correct voltage. See Specifications (page 5).<br><br>With unit plugged in and rocker switch on, check for correct voltage into rocker switch. If low or zero voltage, replace power cord. If voltage is correct, check for correct voltage out of rocker switch. If low or no voltage, replace rocker switch. |
|  | Wiring problem.  | Check all electrical connections for burns, discoloration or arcing. Replace all connections or components with damaged terminals. Replace all damaged wiring with the same (or higher) rated wire.  |
|  | Platen inoperative.  | To check platen:<br><br>Use an Ohm meter to test resistance of the platen heater (disconnect 1 wire to isolate heater). Correct cold resistance for heating element of platen are as follows:<br>120 Volts, 1750 Watts - 7.8 Ohms<br>208 Volts, 2550 Watts - 16.2 Ohms<br>230 Volts, 1900 Watts - 26.5 Ohms VCT-20 only. The auxiliary heaters are 144.2 Ohms at 208V/300 Watts.   |
|  | Conveyor drive motor inoperative or incorrect conveyor motor installed in toaster. | To check drive motor:<br><br>1. Measure resistance of motor coil. Replace motor if coil measures either open circuit or zero resistance.<br><br>2. Mark the drive motor sprocket and count the turns per minute. Correct drive motor speed is nine (9) turns per minute for VCT-20; three (3) turns per minute for VCT-25; one (1) turn per minute for VCT-50.   |
| Product is getting stuck or conveyor belts stop when product is toasting.                    | Bun adjustment controls set incorrectly.   | Measure bun thickness and set bun adjustment controls correctly (page 9).  |
|  | Conveyor release sheet not clean or missing.                                       | Clean respective items. Refer to Maintenance Schedule (page 10).   |



# VERTICAL CONTACT TOASTER

## TROUBLESHOOTING (continued)

| Problem   | Possible Cause  | Corrective Action  |
|---|---|--|
| Product is getting stuck or conveyor belts stop when product is toasting (continued). | Not enough voltage, defective power cord or rocker switch.  | Check receptacle for correct voltage. See Specifications (page 5).<br><br>With unit plugged in and rocker switch on, check for correct voltage into rocker switch. If low or zero voltage, replace power cord. If voltage is correct, check for correct voltage out of rocker switch. If low or no voltage, replace rocker switch.                             |
|   | Wiring problem.   | Check all electrical connections for burns, discoloration or arcing. Replace all connections or components with damaged terminals. Replace all damaged wiring with the same (or higher) rated wire.  |
|   | Conveyor drive motor inoperative or incorrect conveyor motor installed on toaster.  | To check drive motor:<br><br>1. Measure resistance of motor coil. Replace motor if coil measures either open circuit or zero resistance.<br><br>2. Mark the drive motor sprocket and count the turns per minute. Correct drive motor speed is nine (9) turns per minute for VCT-20; three (3) turns per minute for VCT-25; one (1) turn per minute for VCT-50. |
|   | Conveyor Belt chain is loose, worn, or broken or the motor drive sprocket is loose..  | Check drive chain for kinks, broken or bent links or other damage. Check motor sprocket and drive sprockets (on drive shaft); tighten setscrew on flat of shaft if required. Check for damaged/worn sprockets and replace as required.   |
|   | The Conveyor Covers are not installed or are improperly installed.  | Install conveyor cover assy(s).  |
|   | Conveyor Belts chains are installed incorrectly.  | Install conveyor belt to match diagram in Fig. 8 (page 11). Be sure that ends of the hooks are facing down.  |
|   | Conveyor Belt Chains are too loose or are missing links (41 links required when new). When new, the Conveyor Belt chain has 37 large links and 4 small links. | Remove conveyor belt (page 11). Lay belt flat and count links. Replace entire belt if links are damaged. If conveyor belt has too much play, it will jam. Adjust belt length as described under Servicing the Conveyor Belt (page 11).   |
|   | The Spring Tensioners or Tensioners are bent or missing.  | Replace spring tensioner assy(s). (29, page 22) or tensioners (4, page 24) if damaged or loose. Replace slide rails (40, page 24 worn or missing.  |

# VERTICAL CONTACT TOASTER

## TROUBLESHOOTING (continued)

| Problem  | Possible Cause  | Corrective Action  |
|--|---|--|
| Conveyor belts are "jumping" or "snapping".    | Toaster is installed incorrectly.   | Perform installation and operating procedures (pages 7-9).   |
|  | Bun adjustment controls set incorrectly.  | Measure bun thickness and set bun adjustment controls correctly (page 9).  |
|  | Conveyor drive motor inoperative or incorrect conveyor motor installed on toaster.  | To check drive motor:<br><br>1. Measure resistance of motor coil. Replace motor if coil measures either open circuit or zero resistance.<br><br>2. Mark the drive motor sprocket and count the turns per minute. Correct drive motor speed is nine (9) turns per minute for VCT-20; three (3) turns per minute for VCT-25; one (1) turn per minute for VCT-50. |
|  | Conveyor drive chain loose, worn or broken. Loose motor drive sprocket.   | Check drive chain for kinks, broken or bent links or other damage. Check motor sprocket and drive sprockets (on drive shaft); tighten setscrew on flat of shaft if required. Check for damaged/worn sprockets and replace as required.   |
|  | Conveyor belts installed incorrectly.   | Install conveyor belt to match diagram in Fig. 8 (page 10). Be sure that ends of the hooks are facing down.  |
|  | Conveyor belt too loose or missing links (41 links required when new). When new, conveyor has 37 large links and 4 small links. | Remove conveyor belt (page 11). Lay belt flat and count links. Replace entire belt if links are damaged. If conveyor belt has too much play, it will jam. Adjust belt length as described under Servicing the Conveyor Belt (page 11).   |
|  | Spring tensioner assy(s) or tensioner bent or missing.  | Replace spring tensioner assy(s). (29, page 22) or tensioners (4, page 24) if damaged or loose. Replace slide rails (40, page 24) worn or missing.   |
| Crown and/or heel must be forced into toaster. | Heat shield improperly installed.<br><br>Crown and/or heel improperly inserted into toaster.                                    | Remove and reposition heat shield.<br><br>Buns must be inserted with cut faces facing each other; heel in front slot and crown in rear slot.   |

# VERTICAL CONTACT TOASTER

## WIRING DIAGRAM

### Pictorial Wiring Diagram VCT-20 WIRING DIAGRAM

NOTE: ALL WIRES TO BE 14 GA. AWM-105°C  
UNLESS OTHERWISE SPECIFIED.

\* 16 GA. TFE-200°C  
= 18 GA. AWM-105°C  
# 16 GA. AWM-105°C  
% 14 GA. TFE-200°C

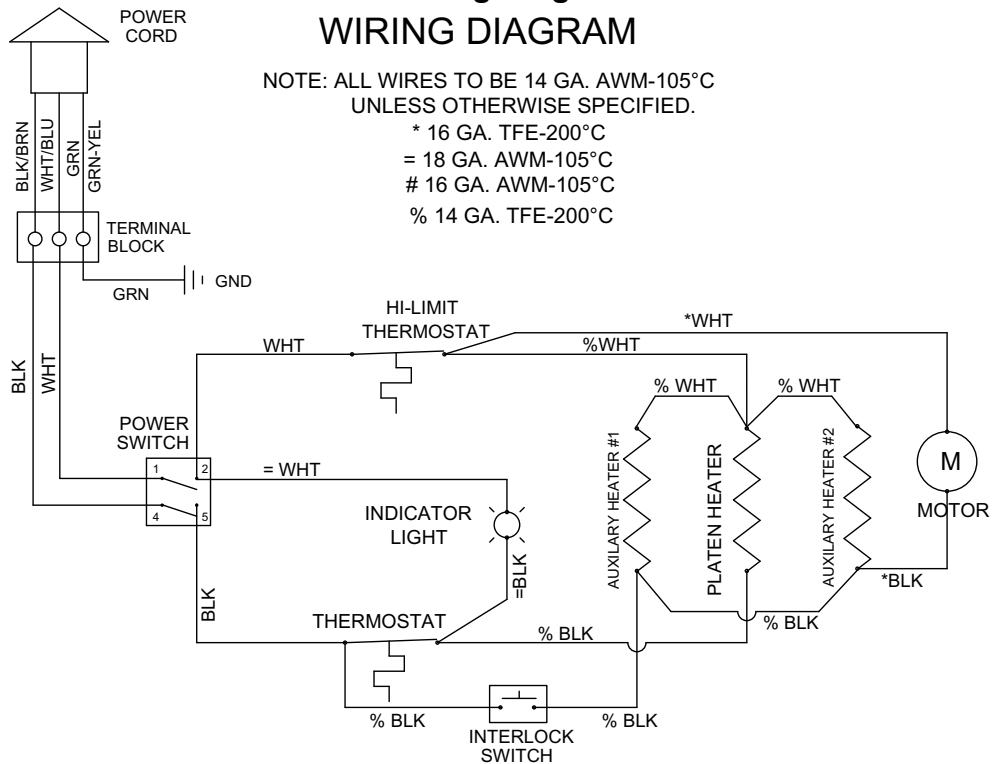

### Pictorial Wiring Diagram VCT-25 & VCT-50 WIRING DIAGRAM

NOTE: ALL WIRES TO BE 14 GA. AWM-105°C  
UNLESS OTHERWISE SPECIFIED.

\* 16 GA. TFE-200°C  
= 18 GA. AWM-105°C  
# 16 GA. AWM-105°C  
% 14 GA. TFE-200°C

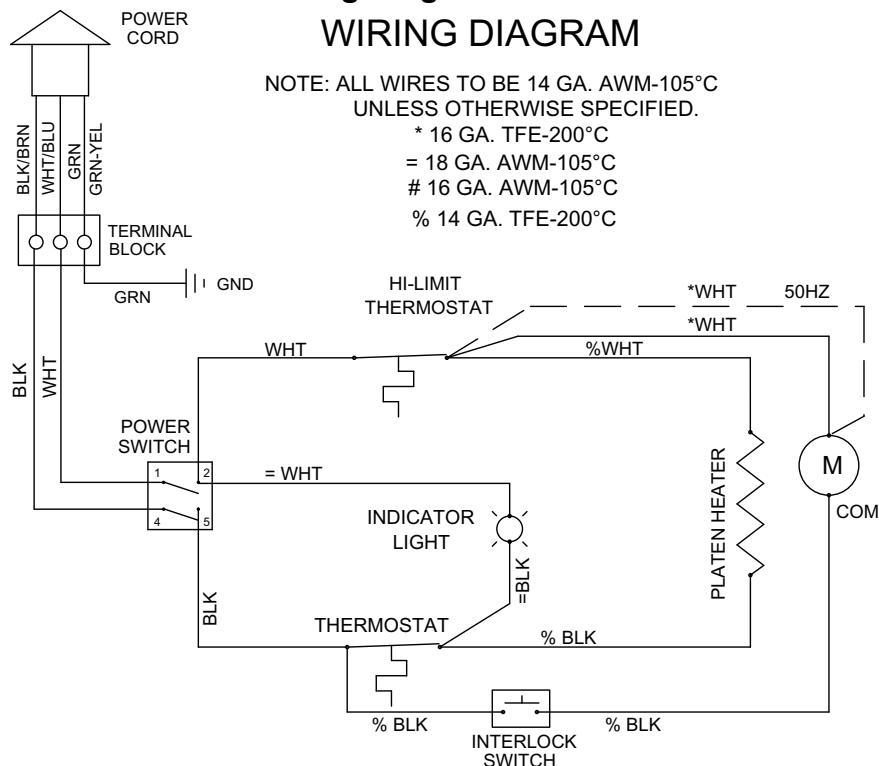

# VERTICAL CONTACT TOASTER

## REPLACEMENT PARTS

### Parts Identification

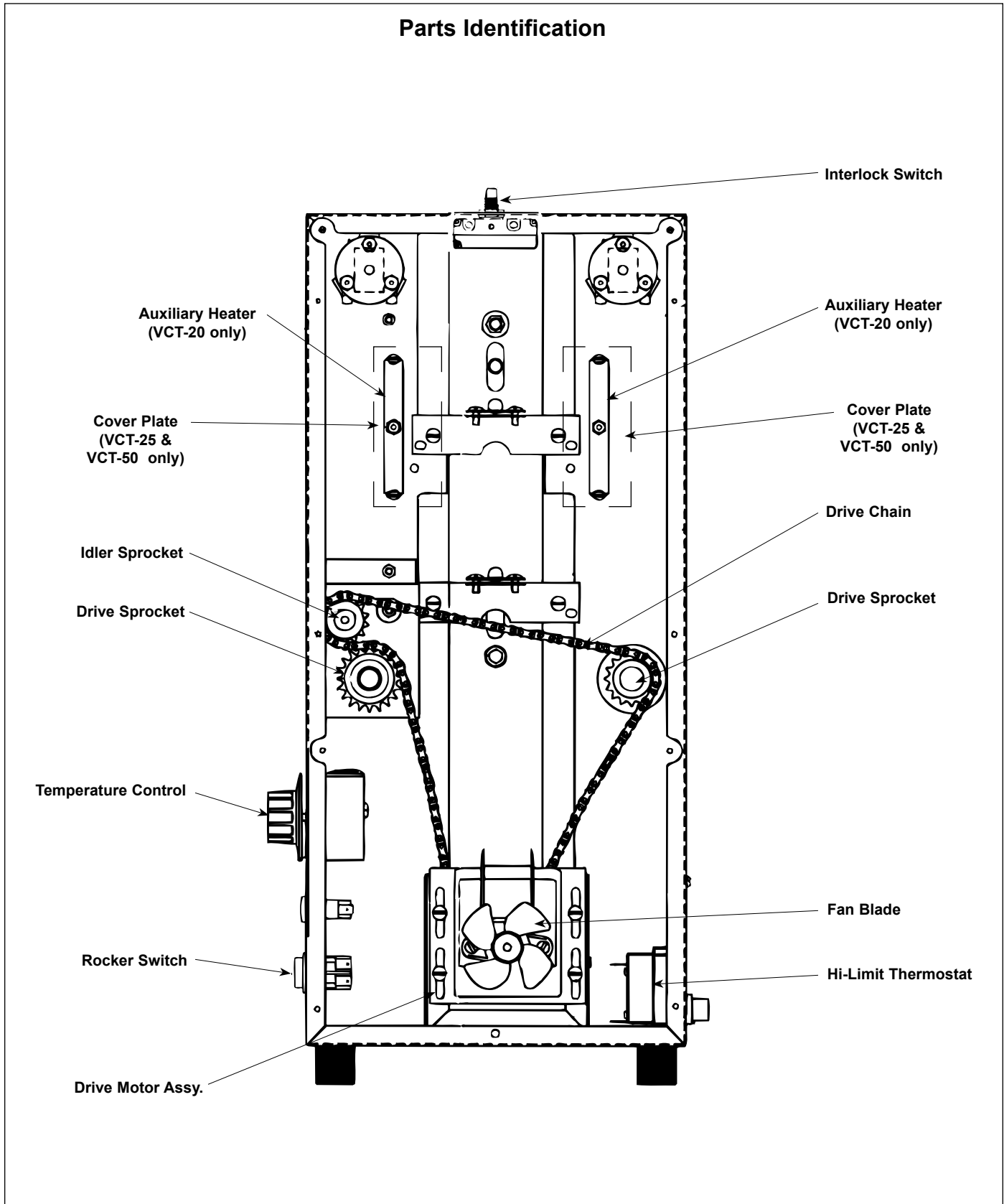

# VERTICAL CONTACT TOASTER

## REPLACEMENT PARTS (continued)

| Item | Part No. | Description   | Qty. | Item | Part No. | Description   | Qty. |
|------|----------|---|------|------|----------|---|------|
| 1    | 0011264  | Conveyor Belt   | 2    | 36   | 2100133  | Knob, Thermostat Control                                    | 1    |
|      | 0800204  | 1/2" Pitch Link, Small  | 4    | 37   | 0021170  | Weldment, End Housing                                       | 1    |
|      | 0800121  | 3/4" Pitch Link, Large  | 37   | 38   | 7000249  | Release Sheet (Pack of 3)                                   | -    |
| 2    | 2150117  | Idler Shaft   | 2    |      | 7000250  | Release Sheet (Pack of 10)                                  | -    |
| 3    | 0011375  | Conveyor Cover Assy.  | 2    | 39   | 0021194  | Weldment, Control Housing                                   | 1    |
| 4    | 0010475  | Tensioner Assy. (Incl. #40, 76, 85)   | 4    | 40   | 7000121  | Slide Rail Kit (Incl. Qty. 2<br>slide rails for tensioners) | 2    |
| 5    | 0800332  | Rod, Conveyor Cover   | 4    | 41   | 0021207  | Conveyor Cam  | 2    |
| 6    | 2150190  | Sprocket  | 8    | 42   | 7000176  | Thermocouple Retainer Kit                                   | 2    |
| 7    | 7000199* | Spacer Kit  | 2    | 43   | 4030332  | High Limit Thermostat                                       | 1    |
| 8    | 0503362  | Control Cover   | 1    | 44   | 0400251  | Strain Relief   | 1    |
| 9    | 2150118  | Drive Shaft   | 2    | 45   | 0400138  | Locknut, 1/2"   | 1    |
| 10   | 0700437  | Power Cord Assy (2.5-16A)<br>W/ IEC-309 Plug (Mfg. No. 9200609<br>& 9200637)  | 1    | 46   | 0503590  | Bracket, Motor  | 1    |
|      | 0700451  | Power Cord 14/3 5-20P<br>(Mfg. No. 9200602 & 9200622)   | 1    | 47   | 0070582  | Wire Set, VCT-20 (not shown)                                | 1    |
|      | 0700452  | Power Cord 14/3 6-20P<br>(Mfg. No. 9200606, 9200614,<br>9200626 & 9200632)  | 1    |      | 0700586  | Wire Set, VCT-25/VCT-25<br>(not shown)                      | 1    |
|      | 0700453  | Power Cord - IntL/HARMZD W/<br>CEE 7/7 Plug (Mfg. No. 9200608,<br>9200616, 9200628, 9200628, 9200629,<br>9200634, 9200639, and 9200640) | 1    | 48   | 0503385  | Bun Chute   | 1    |
|      | 0700463  | Power Cord, 14/3 5-15P<br>(Mfg. No. 9200600, 9200620, 9200624,<br>9200630, and 9200631)   | 1    | 49   | 4030313  | Auxiliary Heater, 300W<br>VCT-20 only MFG# 9200560          | 2    |
|      | 0700552  | Power Cord Assy Commercial/Plug<br>L6-20P (Mfg. No. 9200560)  | 1    | 50   | 331P101* | Nut, Hex, 5/16 x 18"  | 1    |
| 11   | 4030235  | Thermostat, 530° F  | 1    | 51   | 7000229  | Platen (120 Volt)   | 1    |
|      | 4030355  | Thermostat, 122F-600F Adjustable<br>(Mfg. No. 9300639 only)   | 1    |      | 7000200  | Platen (208-240 Volt)                                       | 1    |
| 12   | 2150158  | Ball Bearing  | 2    |      | 7000288  | Platen (230 Volt) (Mfg. No. 9200640 only)                   | 1    |
| 13   | 2150186  | Bearing   | 6    | 52   | 2100266  | Tape  | 2    |
| 14   | 0503459  | Bearing Retainer/Spacer   | 6    | 53   | 4010107  | Interlock Switch  | 1    |
| 15   | 0503376  | Bearing Retainer  | 6    | 54   | 0503150  | Heater Clip, VCT-20 only                                    | 2    |
| 16   | 7000167  | Bearing & Retainer Kit<br>(Includes #13, 14, 15 & 59)   | 1    | 57   | 0503608  | Cover Plate   | 2    |
| 17   | 2150193  | Drive Sprocket, VCT-20  | 2    | 58   | 4000165  | Fan Blade, Motor  | 1    |
|      | 2150109  | Drive Sprocket, VCT-25/VCT-50   | 2    | 59   | 2100256  | Tape, Hi-Temp   | 8    |
| 18   | 2150187  | Drive Chain   | 1    | 61   | 212P118* | Flat Washer, 5/16"  | 1    |
| 19   | 0011299  | Idler Sprocket & Bearing  | 1    | 62   | 0500464  | Retainer, Bearing   | 1    |
| 20   | 0501232  | Bracket, Idler Sprocket   | 1    | 64   | 0011330  | Heat Shield Assy.   | 1    |
| 21   | 0503589  | Bracket, Motor Mounting   | 1    |      | 7000707  | Heat Shield with Dampers<br>(Mfg. No. 9200629 Only)         | 1    |
| 22   | 7000204  | Drive Motor Kit, VCT-20 (Incl. #58)   | 1    |      | 0013013  | Heat Shield With Dampers<br>(Mfg. No. 9200625 Only)         | 1    |
|      | 400K150  | Drive Motor Kit, VCT-50 (120V) (Incl. #58)  | 1    | 65   | 325P163  | Setscrew, 1/4-28 x 5/16"                                    | 8    |
|      | 400K151  | Drive Motor Kit, VCT-50 (230V) (Incl. #58)  | 1    | 66   | 100P864* | Label, Caution Hot  | 1    |
|      | 400K152  | Drive Motor Kit, VCT-25 (120V) (Incl. #58)  | 1    | 67   | 308P154* | Screw, #10-32 x 3/8"  | 2    |
|      | 400K153  | Drive Motor Kit, VCT-25 (230V) (Incl. #58)  | 1    | 68   | 306P104* | Screw, #6-32 x 1/4"   | 8    |
| 23   | 2150173  | Sprocket, Motor, VCT-20   | 1    | 69   | 406P107* | Cable Tie   | 1    |
|      | 2150120  | Sprocket, Motor, VCT-50   | 1    | 70   | 308P143* | Nut, #8-32, "KEPS"  | 6    |
|      | 2150110  | Sprocket, Motor, VCT-25   | 1    | 71   | 310P103* | Screw, #10-32 x 1/4"  | 4    |
| 24   | 7000882  | Rocker Switch Kit, On/Off   | 1    | 72   | 310P140* | Washer, #10   | 6    |
| 25   | 4060355  | Terminal Block  | 1    | 73   | 308P101* | Nut, #8-32  | 3    |
| 26   | 0503495  | Retainer, Tension Bracket, RH   | 2    | 74   | 306P101* | Nut, Hex, #6-32   | 2    |
| 27   | 0503507  | Retainer, Tension Bracket, LH   | 2    | 75   | 306P123* | Screw, #6-32 x 7/8"   | 2    |
| 28   | 4060229  | Indicator Light, Amber (250V)   | 1    | 76   | 308P145* | Nut, Hex Acorn, #8-32                                       | 14   |
|      | 4060323  | Indicator Light, Amber (125V)   | 1    | 77   | 100P900* | Label, Service  | 1    |
| 29   | 0011374  | Spring Tensioner Assy.  | 2    | 78   | 325P104* | Washer, 1/4"  | 4    |
| 30   | 0503496  | Tensioner Bracket, Right  | 2    | 79   | 325P109* | Screw, 1/4-20 x 1/2"  | 4    |
| 31   | 0503497  | Tensioner Bracket, Left   | 2    | 80   | 308P124* | Screw, 1-Way, #8-32 x 1/2"                                  | 1    |
| 32   | 1000899  | Label, Control  | 1    | 81   | 210K230  | Bumper, Recess Leg, 1"                                      | 4    |
| 33   | 10P1047* | Label, Dial (Pack of 10)  | 1    | 82   | 310P136* | Screw, #10-32 x 1-1/4"                                      | 4    |
| 34   | 2100253  | Knob, Cam   | 2    | 83   | 308P133* | Screw, #8-32 x 1/4"   | 12   |
| 35   | 0503390  | Cover, End Housing  | 1    | 84   | 308P151* | Screw, SEMS, #8-32 x 5/16"                                  | 4    |
|      |          |   |      | 85   | 308P181* | Screw, Flat Hd., #8-32 x 3/8"                               | 4    |
|      |          |   |      | 86   | 218P145* | Cover, Leg, Bumper  | 4    |
|      |          |   |      | 87   | 331P103* | Shoulder Bolt, 5/16-18 x 1"                                 | 1    |
|      |          |   |      | 88   | 306P105* | Screw, #6-32 x 1/2"   | 1    |
|      |          |   |      | 89   | 0503455  | Tension Spring, Inner                                       | 4    |
|      |          |   |      | 90   | 2100259  | Slide Bar   | 4    |

\* Only available in packages of 10.

# VERTICAL CONTACT TOASTER

## REPLACEMENT PARTS (continued)

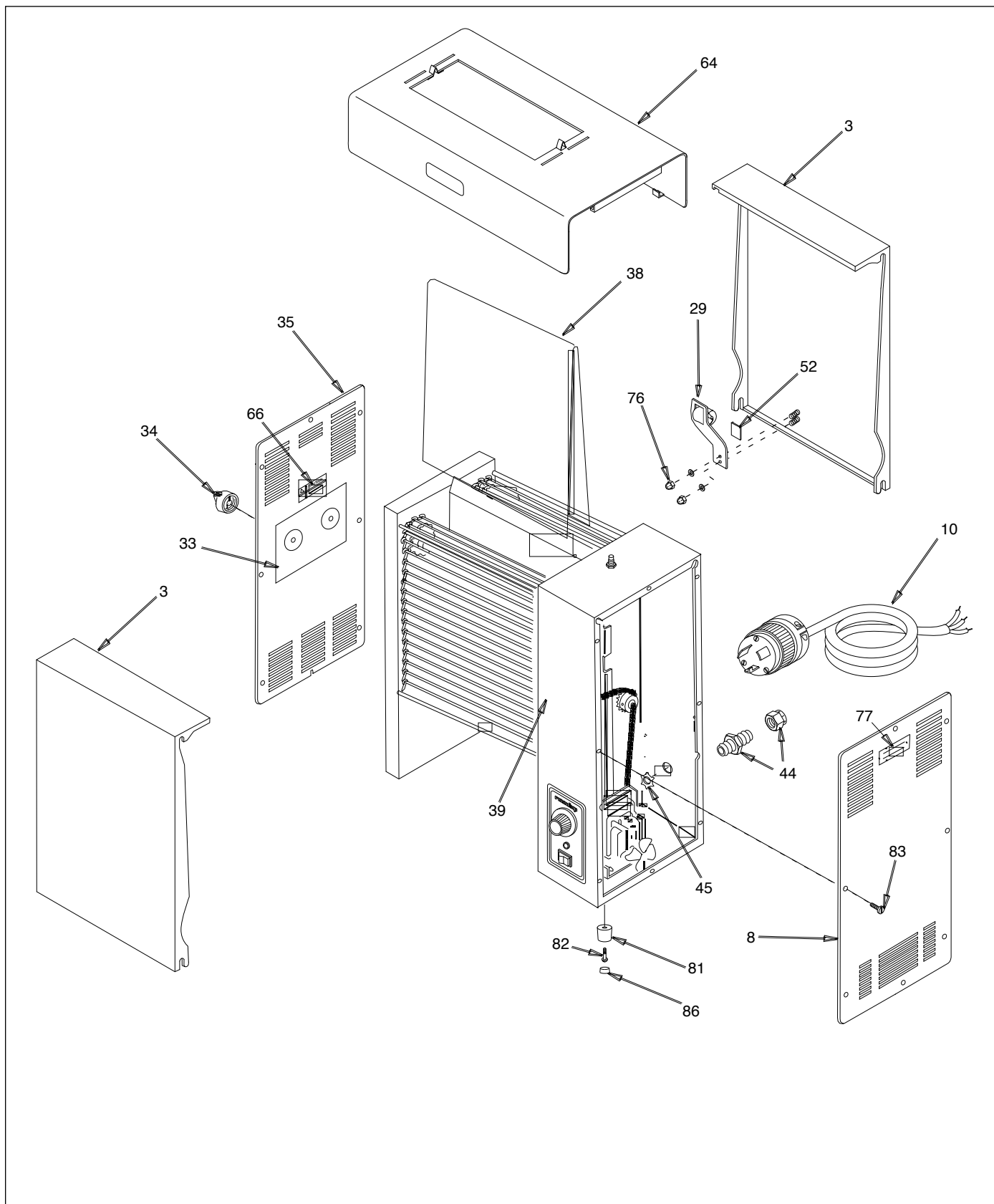

# VERTICAL CONTACT TOASTER

## REPLACEMENT PARTS (continued)

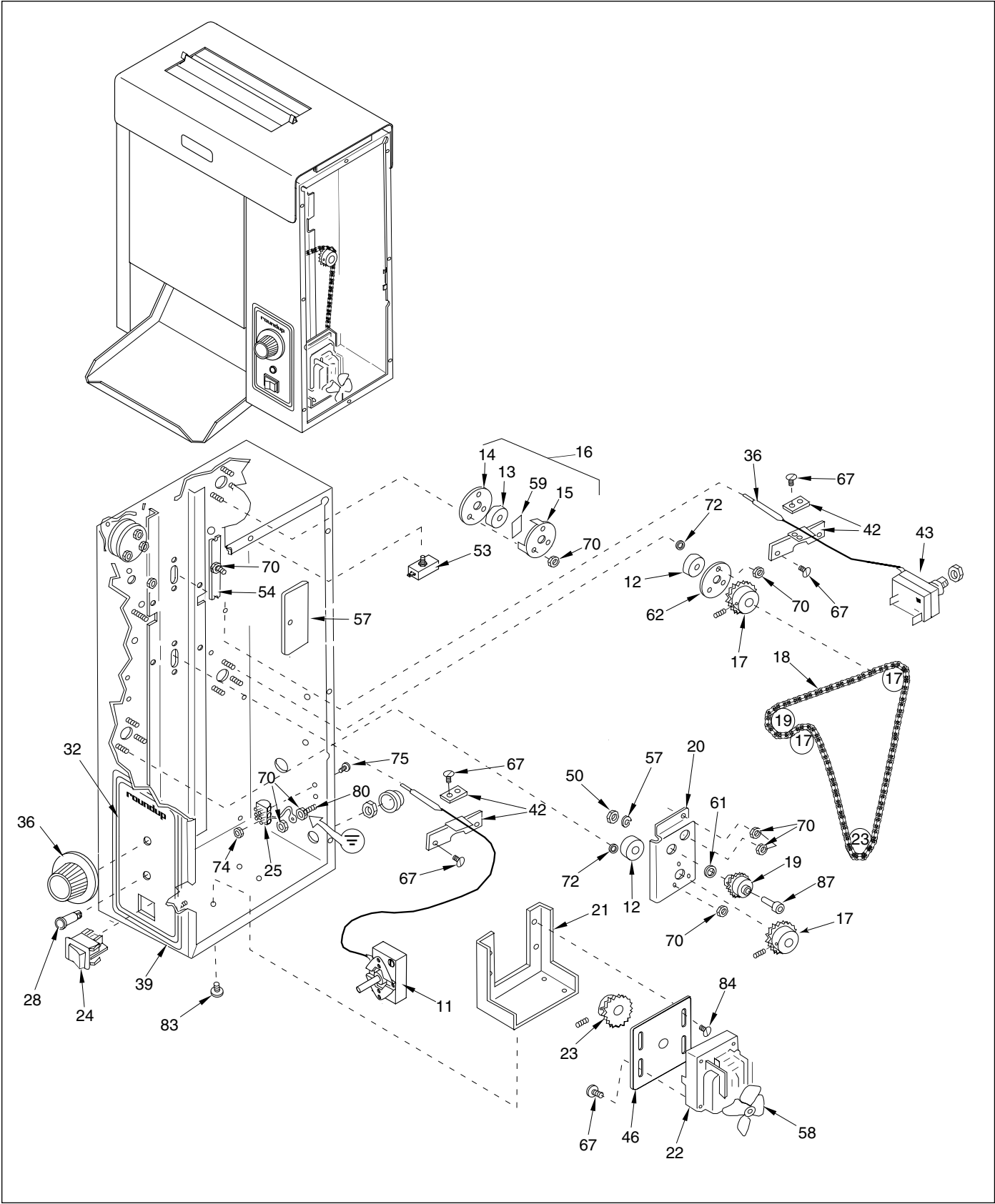

# VERTICAL CONTACT TOASTER

## REPLACEMENT PARTS (continued)

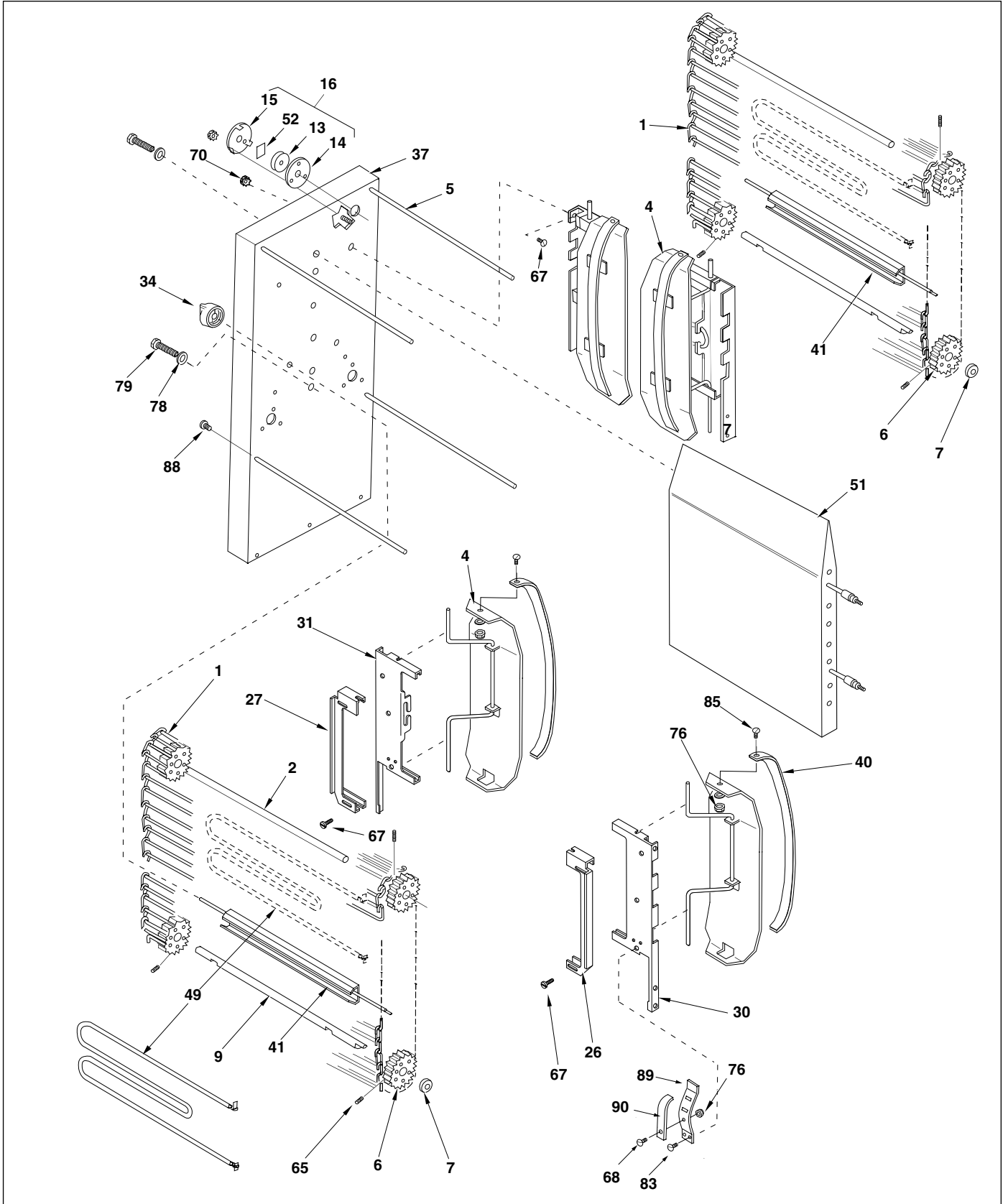



# VERTICAL CONTACT TOASTER

## OPTIONAL PARTS – VCT-25 & VCT-50

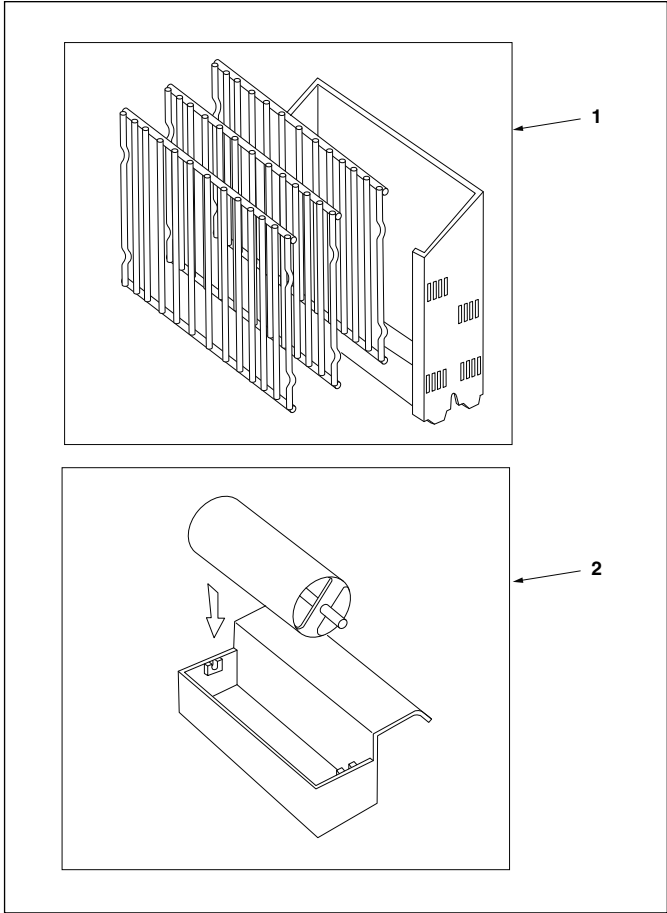

| Item | Part No. | Description      | Qty. |
|------|----------|------------------|------|
| 1    | 7000236  | Bun Feeder       | 1    |
| 2    | 7000238  | Butter Wheel Kit | 1    |





## LIMITED WARRANTY

Equipment manufactured by Roundup Food Equipment Division of A.J. Antunes & Co. has been constructed of the finest materials available and manufactured to high quality standards. These units are warranted to be free from electrical and mechanical defects for a period of one (1) year from date of purchase under normal use and service, and when installed in accordance with manufacturer's recommendations. To insure continued operation of the units, follow the maintenance procedures outlined in the Owner's Manual. During the first 12 months, electro-mechanical parts, non-overtime labor, and travel expenses up to 2 hours (100 miles/160 km), round trip from the nearest Authorized Service Center are covered.

1. This warranty does not cover cost of installation, defects caused by improper storage or handling prior to placing of the Equipment. This warranty does not cover overtime charges or work done by unauthorized service agencies or personnel. This warranty does not cover normal maintenance, calibration, or regular adjustments as specified in operating and maintenance instructions of this manual, and/or labor involved in moving adjacent objects to gain access to the equipment. This warranty does not cover consumable/wear items. This warranty does not cover damage to the Load Cell or Load Cell Assembly due to abuse, misuse, dropping of unit/shock loads or exceeding maximum weight capacity (4 lbs). This warranty does not cover water contamination problems such as foreign material in water lines or inside solenoid valves. It does not cover water pressure problems or failures resulting from improper/incorrect voltage supply. This warranty does not cover Travel Time & Mileage in excess of 2 hours (100 miles/160 km) round trip from the nearest authorized service agency.
2. Roundup reserves the right to make changes in design or add any improvements on any product. The right is always reserved to modify equipment because of factors beyond our control and government regulations. Changes to update equipment do not constitute a warranty charge.
3. If shipment is damaged in transit, the purchaser should make a claim directly upon the carrier. Careful inspection should be made of the shipment as soon as it arrives and visible damage should be noted upon the carrier's receipt. Damage should be reported to the carrier. This damage is not covered under this warranty.
4. Warranty charges do not include freight or foreign, excise, municipal or other sales or use taxes. All such freight and taxes are the responsibility of the purchaser.
5. THIS WARRANTY IS EXCLUSIVE AND IS IN LIEU OF ALL OTHER WARRANTIES, EXPRESSED OR IMPLIED, INCLUDING ANY IMPLIED WARRANTY OR MERCHANTABILITY OR FITNESS FOR A PARTICULAR PURPOSE, EACH OF WHICH IS HEREBY EXPRESSLY DISCLAIMED. THE REMEDIES DESCRIBED ABOVE ARE EXCLUSIVE AND IN NO EVENT SHALL ROUNDUP BE LIABLE FOR SPECIAL CONSEQUENTIAL OR INCIDENTAL DAMAGES FOR THE BREACH OR DELAY IN PERFORMANCE OF THIS WARRANTY.



### U.S. Headquarters

Carol Stream, Illinois

Phone: (630) 784-1000

Toll Free: (800) 253-2991

Fax: (630) 784-1650

### China Facility

Suzhou, China

Phone: 86-512-6841-3637

Toll Free: 86-512-6841-3907

Fax: 400-0-7878-22