

MANUFACTURING

NUMBERS:

9200550
9200552
9200650

roundup
by A.J. Antunes & Co.®

**VERTICAL CONTACT
TOASTER**

Model VCT-20



P/N 1010719 Rev. E 02/13



Owner's Manual

TABLE OF CONTENTS

Owner Information	2	Hi-Limit Reset Button	11
General	2	Fault Codes	12
Warranty Information	2	Maintenance	13
Service/Technical Assistance	3	Maintenance Schedule	13
Important	3	Cleaning the Release Sheet and BeltWraps	13
Important Safety Information	4	Replacing Belt Wraps	14
Specifications	5	Stainless Steel Conveyor Belts—Removing, Servicing & Replacing	15
Electrical Specifications at Listed Voltages	5	Replacing Roller Tensioners.....	15
Electrical Cord & Plug Configurations	5	Replacing Conveyor Motor and Fan Blade	15
Model Designation.....	5	Troubleshooting	17
Dimensions.....	6	Wiring Diagrams	25
Installation	7	Pictorial Wiring Diagram	25
Unpacking.....	7	Ladder Wiring Diagram	26
Assembling the Unit	7	Replacement Parts	27
Equipment Setup	8	Parts Identification	27
Operation	9	Notes	34
Operating Instructions	9	Limited Warranty	36
Temperature Adjustments.....	9		

OWNER INFORMATION

General

The Vertical Contact Toaster Model VCT-20 is designed for contact toasting of buns. The toaster design allows the operator to place buns on both sides of the heated platen at the same time. Buns are placed into the top of the toaster and uniform, golden brown, warm buns are then retrieved at the base of the toaster.

This manual provides the safety, installation and operating procedures for the Vertical Contact Toaster Model VCT-20. We recommend that all information contained in this manual be read prior to installing and operating the unit.

Your Vertical Contact Toaster Model VCT-20 is manufactured from the finest materials available and is assembled to Roundup's strict quality standards. This unit has been tested at the factory to ensure dependable trouble-free operation.

Warranty Information

Please read the full text of the Limited Warranty in this manual.

If the unit arrives damaged, contact the carrier immediately and file a damage claim with them. Save all packing materials when filing a claim. Freight damage claims are the responsibility of the purchaser and **are not** covered under warranty.

The warranty **does not** extend to:

- Damages caused in shipment or damage as result of improper use.
- Installation of electrical service.
- Normal maintenance as outlined in this manual.
- Malfunction resulting from improper maintenance.
- Damage caused by abuse or careless handling.
- Damage from moisture into electrical components
- Damage from tampering with, removal of, or changing any preset control or safety device.

IMPORTANT! Keep these instructions for future reference. If the unit changes ownership, be sure this manual accompanies the equipment.

OWNER INFORMATION (continued)

Service/Technical Assistance

If you experience any problems with the installation or operation of your unit, contact your local Roundup Authorized Service Agency.

Fill in the information below and have it handy when calling your authorized service agency for assistance. The serial number is on the specification plate located on the rear of the unit.

Purchased From: _____

Date of Purchase: _____

Model No.: _____

Serial No.: _____

Mfg. No.: _____

Refer to the service agency directory included with your unit.

Authorized Service Agency

Name: _____

Phone No.: _____

Address: _____

Use only genuine Roundup replacement parts in this unit. Use of replacement parts other than those supplied by the manufacturer will void the warranty. Your Authorized Service Agency has been factory trained and has a complete supply of parts for this toaster.

You may also contact the factory at **1-877-392-7854** if you have trouble locating your local authorized service agency.

IMPORTANT

A.J. Antunes & Co. reserves the right to change specifications and product design without notice. Such revisions do not entitle the buyer to corresponding changes, improvements, additions or replacements for previously purchased equipment.

IMPORTANT SAFETY INFORMATION

Throughout this manual, you will find the following safety words and symbols that signify important safety issues with regards to operating or maintaining the equipment.

WARNING

GENERAL WARNING. Indicates information important to the proper operation of the equipment. Failure to observe may result in damage to the equipment and/or severe bodily injury or death.

WARNING

ELECTRICAL WARNING. Indicates information relating to possible shock hazard. Failure to observe may result in damage to the equipment and/or severe bodily injury or death.

CAUTION

GENERAL CAUTION. Indicates information important to the proper operation of the equipment. Failure to observe may result in damage to the equipment.

WARNING

HOT SURFACE WARNING. Indicates information important to the handling of equipment and parts. Failure to observe caution could result in personal injury.

In addition to the warnings and cautions in this manual, use the following guidelines for safe operation of the unit.

- Read all instructions before using equipment.
- For your safety, the equipment is furnished with a properly grounded cord connector. Do not attempt to defeat the grounded connector.
- Install or locate the equipment only for its intended use as described in this manual. Do not use corrosive chemicals in this equipment.
- Do not operate this equipment if it has a damaged cord or plug, if it is not working properly, or if it has been damaged or dropped.
- This equipment should be serviced by qualified personnel only. Contact the nearest Roundup authorized service facility for adjustment or repair.
- Do not block or cover any openings on the unit.
- Do not immerse cord or plug in water.
- Keep cord away from heated surfaces.
- Do not allow cord to hang over edge of table or counter.

The following warnings and cautions appear throughout this manual and should be carefully observed.

- Turn the unit off, disconnect the power source and allow unit to cool down before performing any service or maintenance on the unit.
- The procedures in this chapter may include the use of chemical products. These chemical products will be highlighted with bold face letters followed by the abbreviated HCS (Hazard Communication Standard). See Hazard Communication Standard manual for the appropriated Material Safety Data Sheets (MSDS).
- The toaster should be grounded according to local electrical codes to prevent the possibility of electrical shock. It requires a grounded receptacle with separate electrical lines, protected by fuses or circuit breaker of the proper rating.
- Bread may burn. Therefore toasters must not be used near or below curtains or other combustible walls and materials. Failure to maintain safe operating distances may cause discoloration or combustion.

IMPORTANT SAFETY INFORMATION (continued)



- When installing conveyor belt wrap, be careful not to wrap it over the upper and lower support rods or permanent damage to belt will occur. Make sure belt wrap is positioned **UNDER** the upper and lower support rods.
- Make sure both ends of belt wrap are aligned evenly before installing belt wrap pin.
- Failure to use release sheets may result in damage to the equipment and loss of warranty coverage.
- All electrical connections must be in accordance with local electrical codes and any other applicable codes.
- **WARNING ELECTRICAL SHOCK HAZARD. FAILURE TO FOLLOW THESE INSTRUCTIONS COULD RESULT IN SERIOUS INJURY OR DEATH.**
 - Electrical ground is required on this appliance.
 - Do not modify the power supply cord plug. If it does not fit the outlet, have a proper outlet installed by a qualified electrician.
 - Do not use an extension cord with this appliance.
 - Check with a qualified electrician if you are in doubt as to whether the appliance is properly grounded.

SPECIFICATIONS

Electrical Specifications at Listed Voltages

Voltage	Watts	Amps	Hertz
208	3400	16.3	60
220	3800	17.3	60
240	4525	18.9	60

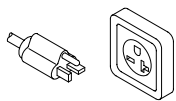
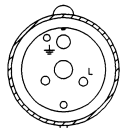
Electrical Cord & Plug Configurations

Letter Code*	Description	Configuration
V	NEMA-6-20P 20 Amp, 250 VAC	
I	International Pin & Sleeve IEC-309 32 Amp, 230 VAC	
C H	Commercial Cord Harmonized Cord	

* Used in Model Designation

⚠ CAUTION ⚠

All electrical connections must be in accordance with local electrical codes and any other applicable codes.

WARNING

ELECTRICAL SHOCK HAZARD. FAILURE TO FOLLOW THE INSTRUCTIONS IN THIS MANUAL COULD RESULT IN SERIOUS INJURY OR DEATH.

- Electrical ground is required on this appliance.
- Do not modify the power supply cord plug. If it does not fit the outlet, have a proper outlet installed by a qualified electrician.
- Do not use an extension cord with this appliance.
- Check with a qualified electrician if you are in doubt as to whether the appliance is properly grounded.

Model Designation

VCT-20XX

TYPE OF POWER CORD

H = HARMONIZED
C = COMMERCIAL

TYPE OF PLUG

I = International Pin and Sleeve
S = Straight Twist-Lock
V = NEMA 6-20P

SPECIFICATIONS (continued)

Dimensions

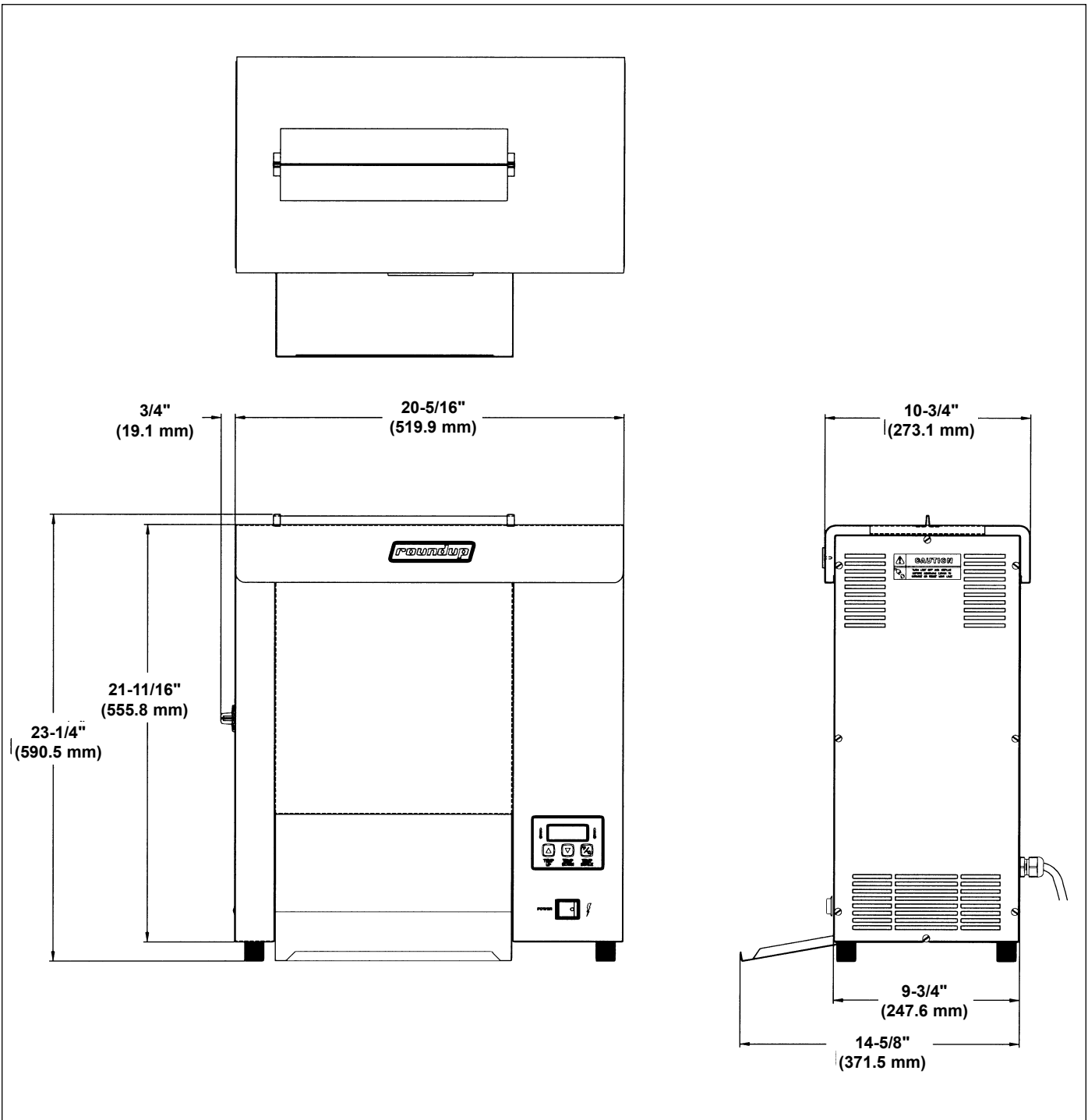

INSTALLATION

Unpacking

1. Remove unit and all packing materials from shipping carton.
2. Open the large box. It should contain the following items
 - damper assembly (Figure 1).
 - bun chute (Figure 2)
 - plastic bag containing the release sheet (Figure 4)
3. Remove all packing materials and protective coverings from the unit and parts.

NOTE: If any parts are missing or damaged, contact Antunes Technical Service IMMEDIATELY at 1-877-392-7854.

Assembling the Unit

1. Remove heat shield from top of the unit. Remove the front and rear conveyor covers.
2. Install the damper assy. (Figure 1).
3. Install the bun chute (Figure 2).
4. Remove the release sheet from the plastic bag and lay it on a clean, flat surface. Fold the sheet *exactly* in half (Figure 3).
5. Crease the sheet at the fold using only your finger (Figure 3).

IMPORTANT: Do not use metal tools to crease the sheet.

6. Install the release sheet by draping it over both sides of the platen surface. The crease should be centered directly on top of the platen (Figure 4).
7. Re-install the front and rear conveyor covers (Figure 4).
8. Install the heat shield assy. The heat shield clips fit over the top of the platen and retains the release sheet (Figure 4).

IMPORTANT: Make sure heat shield assy. is activating (depressing) the conveyor interlock switch (see Figure 4). The conveyors will not rotate unless the heat shield is in place and interlock switch is activated (depressed).

NOTE: Check the release sheet to make sure it is not caught in the conveyor. Additional release sheets can be obtained through your authorized service agency under part no. 7000110 (3 pack) or 7000111 (10 pack).

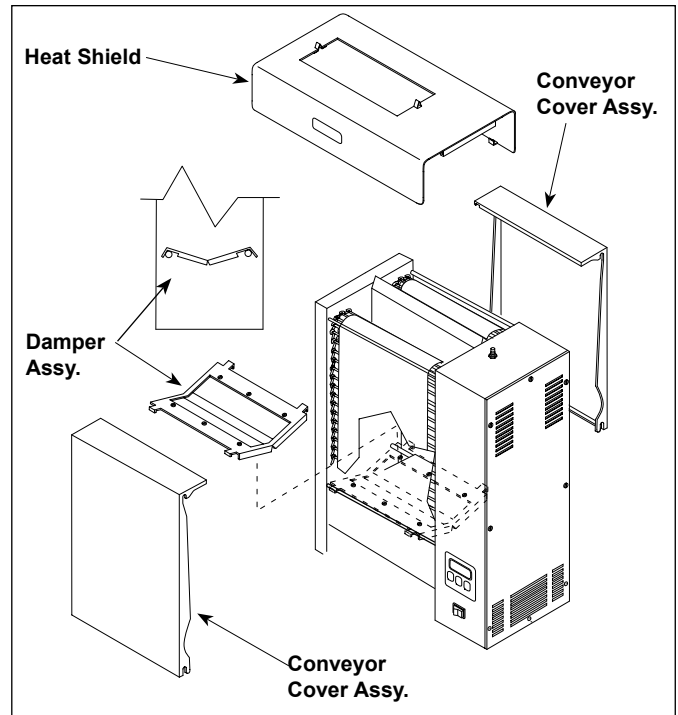

Figure 1. Installing Damper Assy.

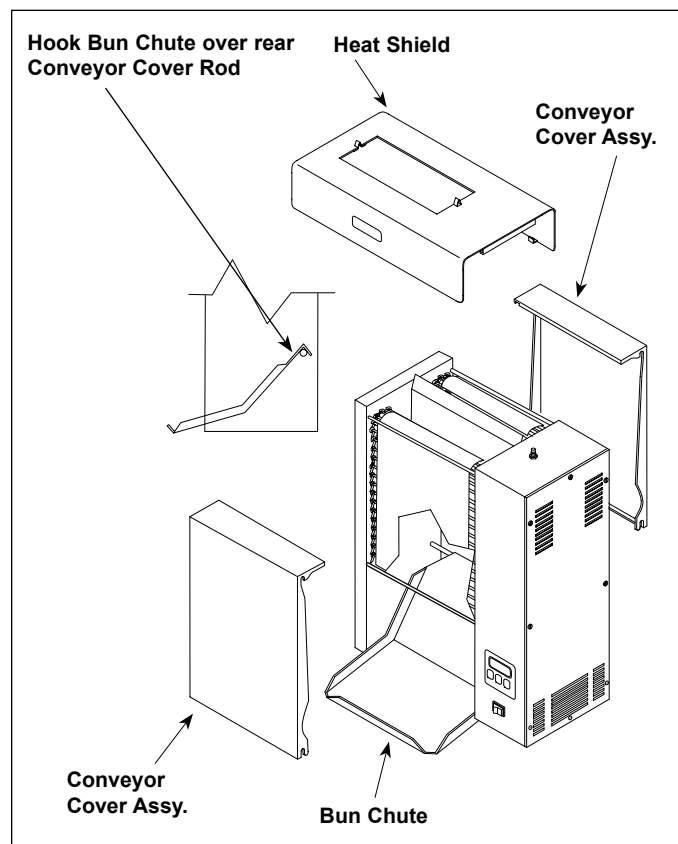

Figure 2. Installing Bun Chute

INSTALLATION (continued)

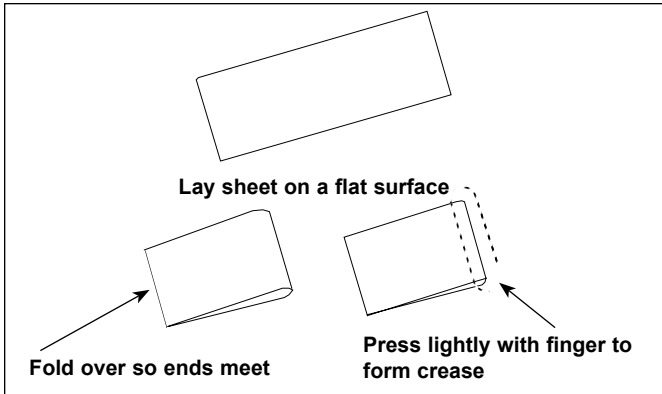

Figure 3. Folding Release Sheet

Equipment Setup

When placing the toaster into service, pay attention to the following guidelines.

⚠ CAUTION ⚠

Failure to use release sheets may result in damage to the unit and loss of warranty coverage.

- Make sure power to the unit is off and the toaster is at room temperature.
- Do not block or cover any openings on the unit.
- Do not immerse cord or plug in water.
- Keep cord away from heated surfaces.
- Do not allow cord to hang over edge of table or counter.
- Connect the unit to the power supply. Refer to the specification plate for the proper voltage.

⚠ CAUTION ⚠

All electrical connections must be in accordance with local electrical codes and any other applicable codes.

⚠ CAUTION ⚠

Bread may burn. Therefore toasters must not be used near or below curtains or other combustible walls and materials. Failure to maintain safe operating distances may cause discoloration or combustion.

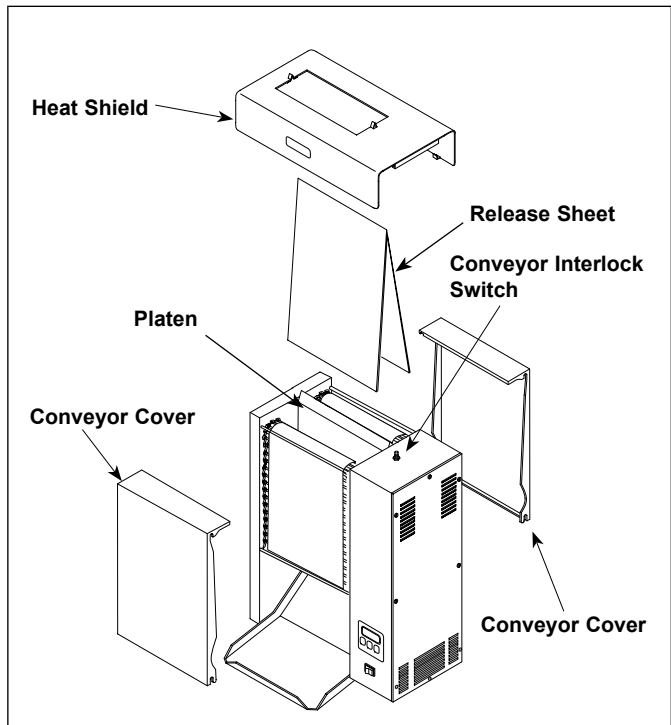

Figure 4. Installing Release Sheet

⚠ WARNING ⚠

ELECTRICAL SHOCK HAZARD. FAILURE TO FOLLOW THE INSTRUCTIONS IN THIS MANUAL COULD RESULT IN SERIOUS INJURY OR DEATH.

- Electrical ground is required on this appliance.
- Do not modify the power supply cord plug. If it does not fit the outlet, have a proper outlet installed by a qualified electrician.
- Do not use an extension cord with this appliance.
- The toaster should be grounded according to local electrical codes to prevent the possibility of electrical shock. It requires a grounded receptacle with separate electrical lines, protected by fuses or circuit breaker of the proper rating.
- Check with a qualified electrician if you are in doubt as to whether the appliance is properly grounded.

OPERATION

Operating Instructions

1. Set the bun adjustment controls (Figure 6) to desired setting.

NOTE: After initial run of 4-6 buns, adjust controls according to the desired finished product.

2. Turn the rocker switch on (Figure 5). Allow 30 minutes warm-up time before proceeding.

NOTE: The temperature display (Figure 5) will flash "LO" until preset operating temperature is reached. When the toaster approaches the preset temperature of 560°F (243°C), "560°F" will appear in the temperature display and the unit is ready to toast buns.

The toaster is tested and shipped with the heaters set at a preset recommended temperature. If "560°F" does not appear in the window after warm-up period, see Temperature Adjustments below for recommended temperature settings and to adjust temperature settings.

3. Drop buns into toaster (Figure 5). **Cut sides of heel and crown must face each other (crown in front, heel in back).**
4. Toasted product will drop into the bun landing area (Figure 5).
5. Test at least 4 buns before putting toaster into service.
6. Turn the rocker switch off when finished toasting.

Temperature Adjustments

The VCT-20 uses a platen heater and two auxiliary heaters. The platen heater consists of a heating coil built into the platen to toast the cut side of the bun. The two auxiliary heaters assist in providing additional heat to the buns. The first auxiliary heater is located between the conveyor in the front of the toaster. The second auxiliary heater is located between the conveyor and the rear of the unit.

RECOMMENDED TEMPERATURES

Recommended temperature setting for the platen heater is 560°F (293°C).

Recommended temperature setting for the auxiliary heaters is 340°F (171°C).

NOTE: The toaster is tested and shipped with the heaters set at the above recommended temperatures.

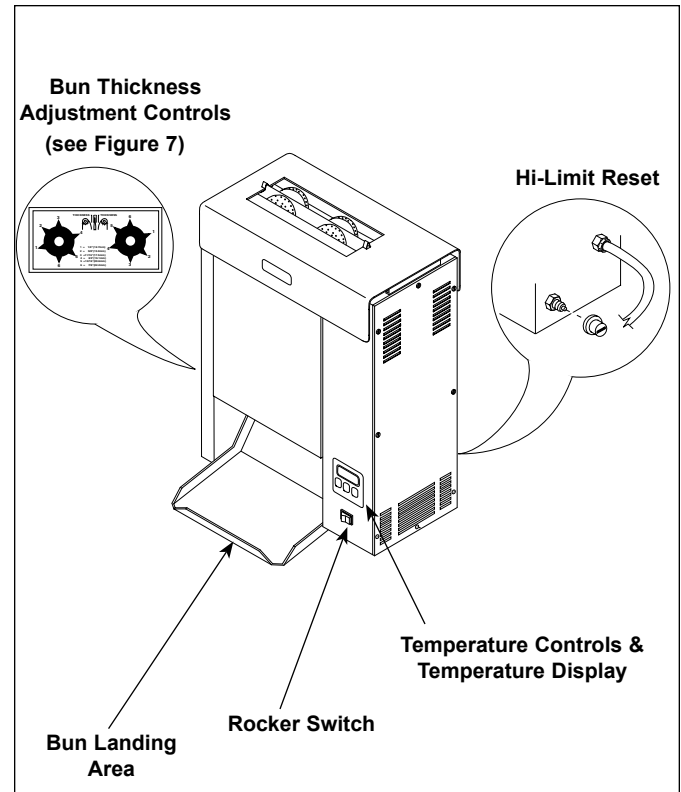

Figure 5. VCT-20 Toaster

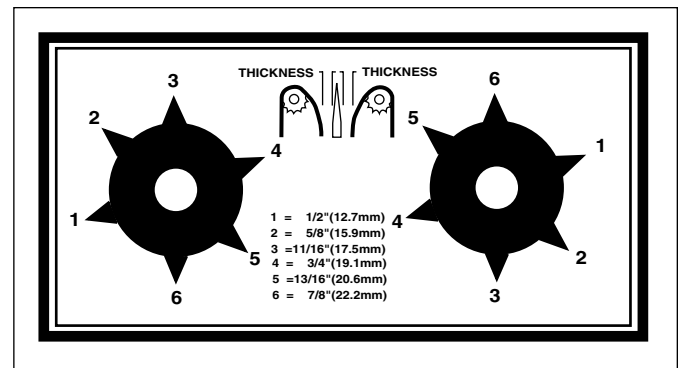

Figure 6. Bun Thickness Adjustment Controls

OPERATION (continued)

TEMPERATURE CONTROL PANEL

NOTE: Setpoint Temperature refers to the desired temperature setting.

Pressing the TEMP UP key will display the current platen heater temperature providing the platen temperature is over 400°F (204°C).

Pressing the TEMP DOWN key will display the current auxiliary heaters temperature providing the auxiliary heaters temperature is over 300°F (148°C).

Pressing TEMP SCALE key will switch the temperature display between Fahrenheit (°F) and Celsius (°C).

PLATEN HEATER TEMPERATURE ADJUSTMENT

1. Turn rocker switch on and wait for temperature display to finish the power up sequence (Figure 7).
2. Press and hold both TEMP UP and TEMP DOWN keys for over 1 second until the display flashes the setpoint temperature, then release (Figure 8).
3. Press the TEMP UP key to raise the setpoint temperature or press the TEMP DOWN key to lower the setpoint temperature. The setpoint temperature will adjust 1° every 0.1 seconds.
4. Release the key when the desired setpoint is displayed.

NOTE: If no change is made within 5 seconds, the display will revert back to the previous setpoint.

AUXILIARY HEATER TEMPERATURE ADJUSTMENT

1. Turn rocker switch on and wait for temperature display to finish the power up sequence (Figure 7).
2. Press and hold both TEMP UP and TEMP SCALE keys for over 1 second until the display flashes the setpoint temperature, then release (Figure 9).
3. Press the TEMP UP key to raise the setpoint temperature or press the TEMP DOWN key to lower the setpoint temperature. The setpoint temperature will adjust 1° every 0.5 seconds. Continuing to depress the key for over two consecutive seconds will increase the adjustment speed 1° every 0.1 seconds.
4. Release the key when the desired setpoint is displayed.

NOTE: If no change is made within 5 seconds, the display will revert back to the previous setpoint.

“Heat On” LED will blink on/off during warm-up and when either platen or auxiliary heaters are calling for heat.

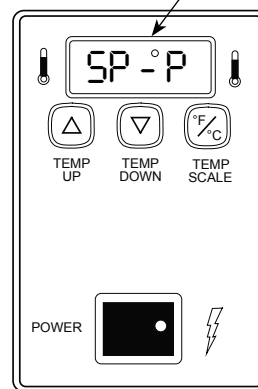

1. SP-P (Setpoint Platen) is displayed

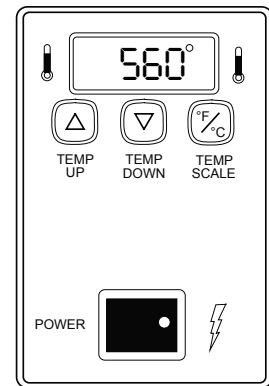

2. Current Platen Temperature setting is shown

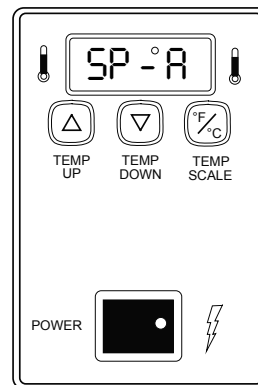

3. SP-A (Setpoint Auxiliary) is displayed

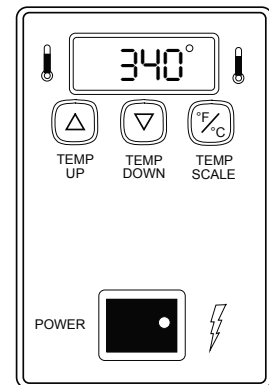

4. Current Auxiliary Temperature setting is shown

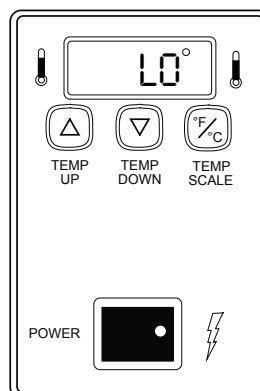

5. “LO” is displayed until platen temperature rises above 520°F (271°C)

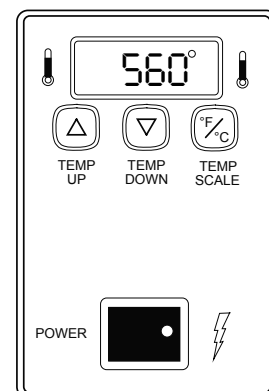

6. Setpoint is displayed when Platen Setpoint Temperature* is reached

* Platen setpoint temperature must be between 520°F (271°C) and 590°F (310°).

FIGURE 7. TEMPERATURE POWER UP SEQUENCE

OPERATION (continued)

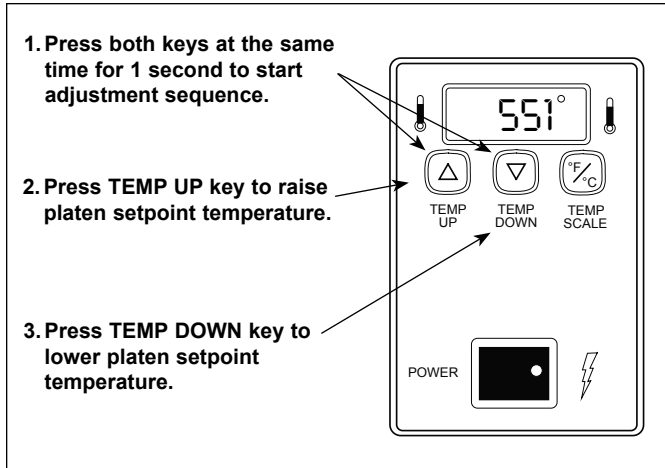

Figure 8. Adjusting Platen Heater Temperature Setpoint

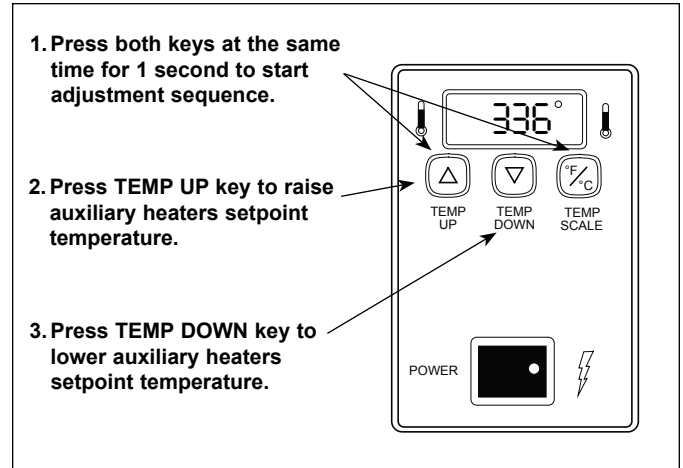

Figure 9. Adjusting Auxiliary Heaters Temperature Setpoint

Hi-Limit Reset Button

A hi-limit thermostat will turn off electrical power to the heater and control circuits if the unit overheats. To reset this thermostat, allow sufficient time (10-15 minutes) for the unit to cool down, then depress the reset button located on the rear of the unit (Figure 5).

If the unit requires continuous resetting, contact your Roundup authorized service agency.

OPERATION (continued)

Fault Codes

 <p>If the toaster control board resembles the OLD style shown here, refer to the Fault Message in Table 1.</p>	
FAULT CODE ON DISPLAY	FAULT CODE DESCRIPTION
"HI" Flashes on display	The platen thermocouple is disconnected or open or the platen relay is shorted. Call for service.
"HI" and "LO" flashes at cold start up	The auxiliary thermocouple is disconnected or open. Call for service.
"HI" and "USE" flashes after 30 minutes of pre-heat time	The auxiliary thermocouple is disconnected or open or the auxiliary relay is shorted. Call for service.
"CHEC"	The electrical compartment ambient temperature is above 140° F (60° C). All heaters will shut off. Check for proper airflow. Call for service.
"PO"	The incoming voltage has dropped below 175 VAC. All heaters will shut off. Call for service.

Table 1

 <p>If the toaster control board resembles the NEW style shown here, refer to the Fault Message in Table 2.</p>	
FAULT CODE ON DISPLAY	POSSIBLE CAUSE(S)
Err 1	Failed Control Board (Call for Service)
Err 2	Failed Control Board (Call for Service)
Err 3	The programming dip switches were not adjusted upon installation of the universal control board. The dip switches must be adjusted to match the toaster Mfg #. Refer to document P/N 1011052 for specific settings.
Err 4	Platen Thermocouple is shorted to chassis ground (Call for Service)
Err 5	Platen Thermocouple is Loose or Disconnected or Open (Call for Service)
Err 6	Failed Control Board (Call for Service)
Err 7	Failed Control Board (Call for Service)
Err 8	Failed Control Board (Call for Service)
Err 9	The programming dip switches were not adjusted upon installation of the universal control board. The dip switches must be adjusted to match the toaster Mfg #. Refer to document P/N 1011052 for specific settings. NOTE: If the dip switches were adjusted correctly, then the AC Isolator Board or its wiring is faulty. (Call for Service)
Err 10	Failed Control Board (Call for Service)
CHEC	Ambient in electrical compartment has exceeded 140 F (60 C). Check for proper airflow. (Call for Service)

Table 2

MAINTENANCE

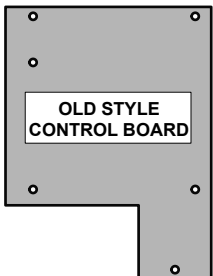
⚠ WARNING ⚠

Turn the unit off, disconnect the power source and allow the unit to cool down before performing any service or maintenance on the unit.

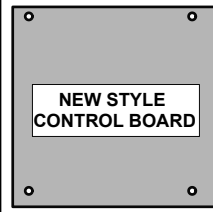
Maintenance Schedule

DAILY

1. Turn off power to the toaster.
2. When the toaster is cool, follow the procedures under *Cleaning the Release Sheet and Belt Wraps*.
3. Remove heat shield and bun chute. Wash in back sink, sanitize and rinse.
4. Wipe down the outside of the toaster and allow to air dry.

Cleaning the Release Sheet and BeltWraps

1. Turn the rocker switch to off, unplug the unit and allow it to cool down.
2. Put on protective gloves. Remove heat shield and release sheet (Figure 10).
3. Wipe release sheet with a clean, sanitized towel.
4. Remove front and rear conveyor cover assys. (Figure 11). Wipe exterior of belt wraps with a clean, sanitized towel.

5. Press interlock switch to rotate conveyors (Figure 14). Count to 10, then turn toaster off, and wipe new section of belt wrap. Re-install the front and rear cover assemblies.
6. Install the release sheet by draping it over both sides of the platen with the crease centered directly on the platen (Figure 10).
7. Install the heat shield (Figure 10). The heat shield clips fit over the tip of the platen and retain the release sheet.

⚠ CAUTION ⚠

To prevent damage to the unit, do not use abrasive cleaners on the release sheet or belt wrap.

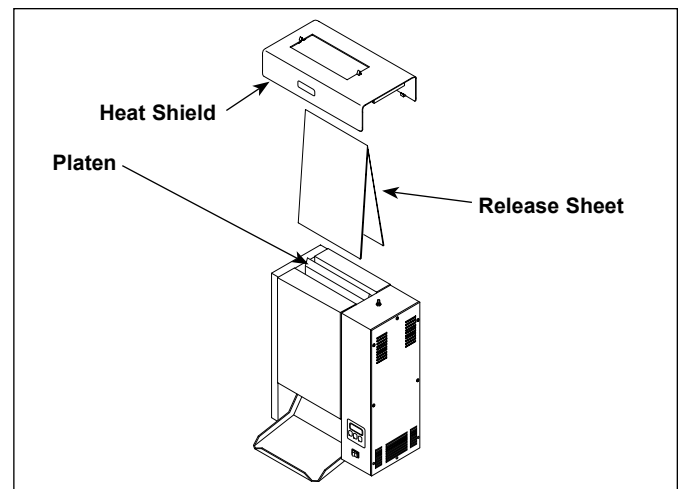

Figure 10. Removing/Installing Release Sheet

MAINTENANCE (continued)

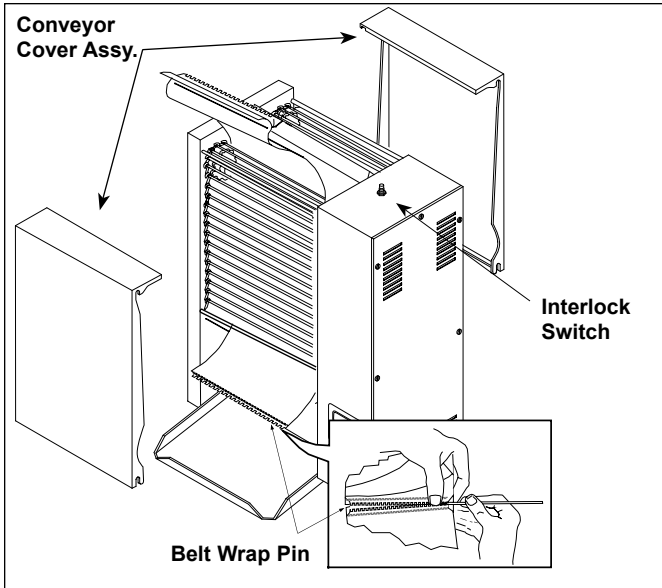

Figure 11. Removing Belt Wrap

NOTE: Check the release sheet to make sure it is not caught in the conveyor. Additional release sheets can be obtained through your authorized service agency under part no. 7000110 (3 pack) or 7000111 (10 pack).

Replacing Belt Wraps

1. Turn off rocker switch, unplug the power cord and allow the unit to cool down before proceeding.
2. Remove the Heat Shield, Front Conveyor Cover, Rear Conveyor Cover, Bun Chute and Release Sheet.
3. Turn bun compression Control Knobs to "6" (Figure 6).
4. Move belt wraps until connecting hinge is exposed and centered, then remove both front and rear belt wraps (Figure 11).
5. The belt wraps must be installed properly in order to work correctly (Figure 12).

⚠ CAUTION ⚠

Be sure conveyor belt wrap is positioned UNDER the upper and lower support rods or damage to the unit will occur.

⚠ CAUTION ⚠

Be sure conveyor belt wrap ends are aligned as shown in Figure 13 or damage to the conveyor belt wrap will occur.

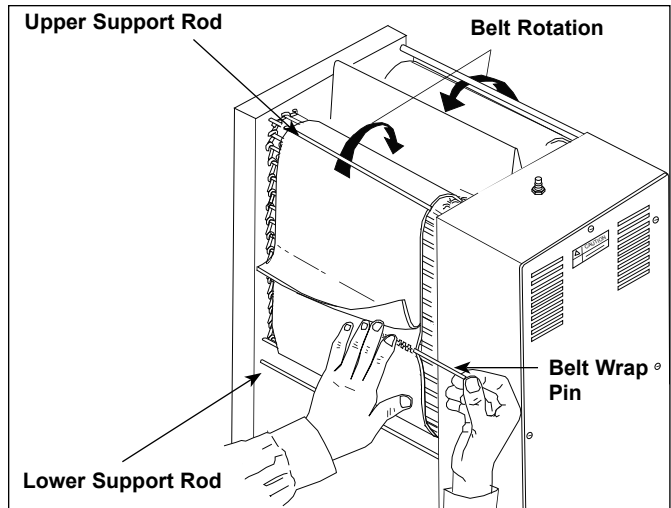

Figure 12. Installing Belt Wrap

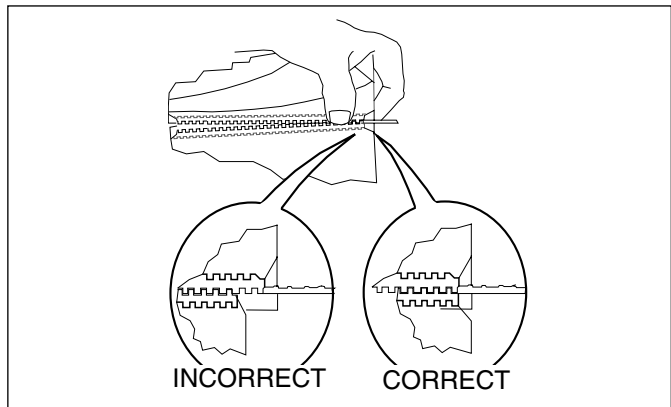

Figure 13. Aligning Belt Teeth

6. Install the belt wraps as shown in Figures 12 & 13.
7. Set bun compression control knobs to "6" (Figure 6).
8. Install a new release sheet (Figure 11).
9. Install the front conveyor cover and rear conveyor cover.
10. Push the cover so the top cover slots slide over the top conveyor support rods and latch into place.
11. Install bun chute and heat shield.

Stainless Steel Conveyor Belts—Removing, Servicing & Replacing

REMOVING THE CONVEYOR BELT

1. Perform steps 1 - 4 under *Replacing Belt Wraps* on the previous page.

NOTE: When replacing conveyor belt, it is recommended that the release sheet and conveyor belt wrap cleaning procedures be performed.

2. Disconnect the conveyor belt by squeezing any two links together and unhooking both ends of one link (Figure 14). Remove conveyor belt.

NOTE: With conveyor belt removed, the tensioner assemblies (4, page 30) and slide rails (40, page 30) can be replaced.

SERVICING CONVEYOR BELTS

After a period of time, the conveyor rods will wear and the conveyor belt will stretch. This will eventually cause the conveyor to jam as it rotates on the sprockets. This is easily remedied by removing one or more conveyor links from each side of the belt.

There are four 1/2" long links on each side of the conveyor belt. The rest of the links are 3/4" long.

1. Remove conveyor belt as described previously on this page.
2. To shorten a stretched conveyor belt, remove one 1/2" link from the belt.
3. Reassemble the belt to the sprockets as described below.

NOTE: If the belt is too short to be reassembled, remove an additional 1/2" link and install a 3/4" link. This will shorten the belt 1/4" overall.

REPLACING CONVEYOR BELTS

1. Remove old conveyor belt as described previously on this page.
2. Place replacement conveyor belt on top sprockets. Check for correct positioning (Figure 14).

NOTE: Install conveyor belt so that the ends of the hooks are facing down.

3. Wrap conveyor belt around lower sprockets and connect by hooking both ends of the belt back together.
4. Perform steps 5 - 11 under *Replacing Belt Wraps* (previous page).

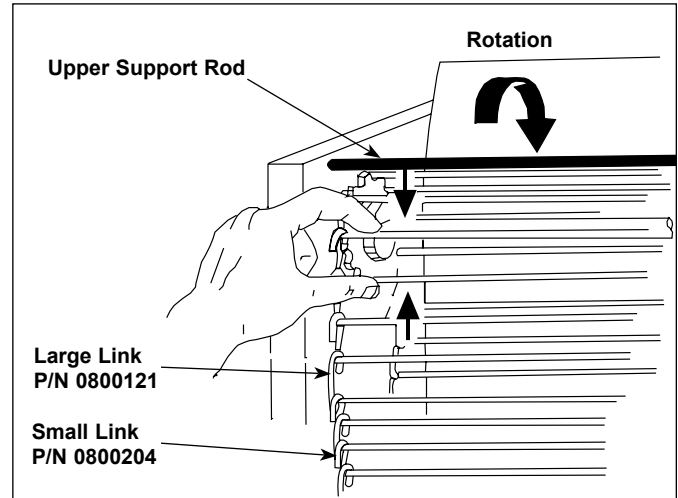

Figure 14. Removing Conveyor Belt

Replacing Roller Tensioners

⚠ WARNING ⚠

Turn the unit off, disconnect the power source and allow the unit to cool down before performing any service or maintenance on the unit.

1. Remove acorn nuts (Figure 15).
2. Remove old roller tensioner assy.
3. Replace tensioner assy. and reassemble.
4. Make sure the spacers are placed inside the tensioner arm. The spacers are smaller than the holes to allow the tensioner to pivot freely.

Replacing Conveyor Motor and Fan Blade

⚠ WARNING ⚠

Turn the unit off, disconnect the power source and allow the unit to cool down before performing any service or maintenance on the unit.

NOTE: A small amount of threadlocker is required for proper gear motor installation.

1. Remove control cover (8, Page 25)
2. Disconnect the motor wires and remove the drive motor and drive motor bracket (Figure 19). Discard the 8-32 x 5/16" mounting bracket screws.
3. Remove the motor sprocket using a hex wrench.
4. Remove the drive motor bracket from the gear motor. Save the four 10-32 x 3/8" pan head screws (P/N 310P154).

MAINTENANCE (continued)

5. Place one drop of treadlocker into each threaded hole in the gear reducer casting. Attach the drive motor bracket to the gear reducer using the original four 10-32 x 3/8" screws (310P154) removed in step 3.
6. Attach the motor sprocket to the gear reducer as shown in Figure 16.

NOTE: Be sure sprocket setscrew is positioned on the flat of the gear reducer shaft. Maintain the 3/16" dimension as shown in Figure 17. Apply threadlocker to threads of setscrew and tighten securely.

7. Using the four new 8-32 x 5/16" stainless steel SEMS truss head screws (P/N 308P151), attach the drive motor bracket to the mounting bracket. DO NOT tighten screws at this time.
8. Place the drive chain on the sprocket and push down on motor. Allow 1/4" (0.6 mm) play at middle of drive chain, then tighten mounting screws while holding motor. Check drive chain play after tightening screws.
9. Re-connect motor wires, one at a time.
10. Re-install control cover.

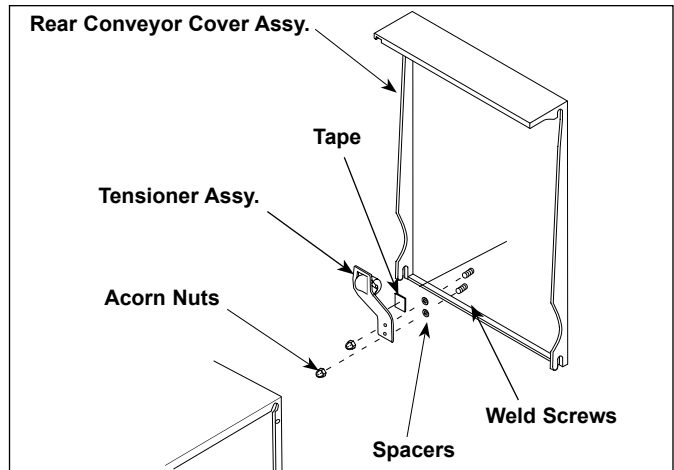

Figure 15. Replacing Roller Tensioner Assy.

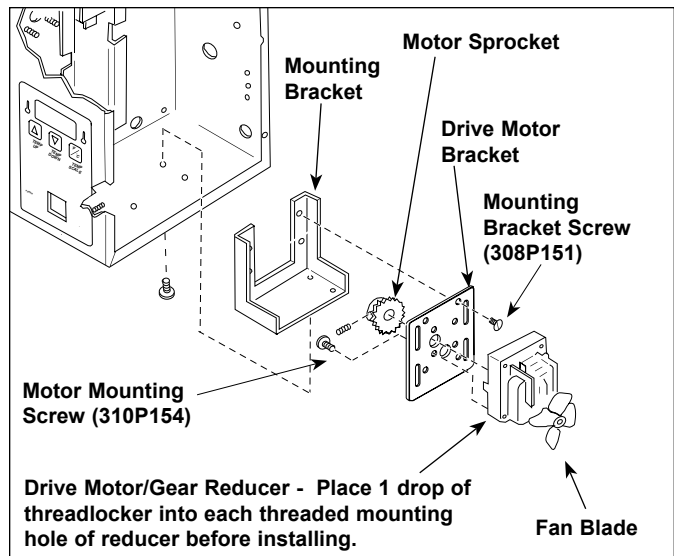

Figure 16. Replacing Drive Motor and Fan Blade

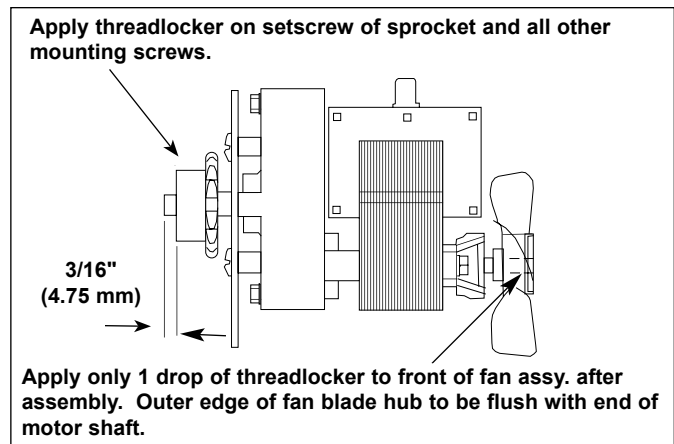

Figure 17. Replacing Drive Motor and Fan Blade

TROUBLESHOOTING
⚠ WARNING ⚠

To avoid possible personal injury and/or damage to the unit, inspection, test and repair of electrical equipment should be performed by qualified service personnel. The unit should be unplugged when servicing, except when electrical tests are required. Use extreme care during electrical circuit tests. Live circuits will be exposed.

Problem	Possible Cause	Corrective Action
No heat and conveyor belts do not move.	Toaster is installed incorrectly.	Perform installation and operating procedures (pages 6-11).
	No voltage, defective power cord, defective rocker switch.	Check receptacle for correct voltage. See Specifications (page 4). With unit plugged in and rocker switch on, check for correct voltage into rocker switch. If low or zero voltage, replace power cord. If voltage is correct, check for correct voltage out of rocker switch. If low or no voltage, replace rocker switch.
	Hi-limit switch tripped open.	Reset hi-limit switch (Fig. 5, page 8).
	Wiring problem.	Check all electrical connections for burns, discoloration or arcing. Replace all connections or components with damaged terminals. Replace all damaged wiring with the same (or higher) rated wire.
No heat and conveyor belts move.	Wiring problem.	Check all electrical connections for burns, discoloration or arcing. Replace all connections or components with damaged terminals. Replace all damaged wiring with the same (or higher) rated wire.
	Inoperative temperature display control or platen.	To check temperature display control, allow unit to warm up for 30 minutes, then: 1. Check platen temperature at the center of platen (with conveyor belt wrap, conveyor belt, tensioners and release sheet removed). Use a pyrometer to confirm temperature readings. 2. After platen temperature reaches a maximum of 559°- 561°F (292°- 293°C) and auxiliary heaters reach a maximum of 339°- 341°F (170°- 172°C) , and the temperature begins to drop, the heat indicator light on the temperature control board should turn on. If test readings do not agree with these figures, replace temperature display control.

Problem	Possible Cause	Corrective Action
No heat and conveyor belts move (continued).	Inoperative temperature display control or platen (continued).	To check platen: Use an Ohm meter to test resistance of the platen heater (disconnect 1 wire to isolate heater). Correct cold resistance for heating element of platen is 17.81 Ohms at 208V/2550 Watts. The auxiliary heaters are 108.2 Ohms at 208V/400 Watts.
	Ambient temperature in control compartment too high.	"CHEC" is showing in temperature display. Turn toaster off and allow control compartment to cool down to 140°F (60°C) and restart toaster. Be sure cooling fan is operating and nothing is blocking the flow of cooling air to bottom of toaster.
Platen is hot and conveyor belts do not move.	Wiring problems.	Check all electrical connections for burns, discoloration or arcing. Replace all connections or components with damaged terminals. Replace all damaged wiring with the same (or higher) rated wire.
	Drive motor inoperative or incorrect conveyor drive motor.	To check drive motor: 1. Measure resistance of motor coil. Replace motor if coil measures either open circuit or zero resistance. 2. Mark the drive motor sprocket and count the turns per minute. Correct drive motor speed is nine (9) turns per minute.
	Broken drive chain or loose sprocket.	Check drive chain for kinks, broken or bent links or other damage. Check motor sprocket and drive sprockets (on drive shaft); tighten setscrew on flat of shaft if required. Check for damaged/worn sprockets and replace as required.
	Conveyor belts installed incorrectly.	Install conveyor belt to match diagram in Fig. 17 (page 13). Be sure that ends of the hooks are facing down.
	Conveyor interlock switch not depressed or faulty.	Install heat shield correctly or replace switch.
	Roller tensioner assy. bent or missing.	Replace roller tensioner assy(s). (29, page 26).
	Conveyor belts too loose (excessive slack).	See Servicing Conveyor Belts (page 13).

Problem	Possible Cause	Corrective Action
<p>Product is over-toasted or platen heat is too high or drop time is too slow.</p>	<p>Conveyor belt wraps dirty and not permitting belt to pull buns across the platen in required time.</p>	<p>Clean belt wrap as described on page 12. Follow directions carefully.</p>
	<p>Temperature set too high.</p>	<p>Reset platen temperature to 560°F (293°C).</p>
	<p>Bun adjustment controls set incorrectly.</p>	<p>Measure bun thickness and set bun adjustment controls correctly (Fig. 6, page 8).</p>
	<p>Buns sticking on release sheet or conveyor belt wrap.</p>	<p>Clean or replace release sheet or conveyor belt wrap.</p>
	<p>Belt wrap not tacky.</p>	<p>Clean or replace belt wrap.</p>
	<p>Conveyor cover assy(s) not installed.</p>	<p>Install conveyor cover assy(s).</p>
	<p>Conveyor belts installed incorrectly.</p>	<p>Install conveyor belt to match diagram in Fig. 17 (page 13). Be sure that ends of the hooks are facing down.</p>
	<p>Defective temperature display control or defective platen.</p>	<p>To check temperature display control, allow unit to warm up for 30 minutes, then:</p> <ol style="list-style-type: none"> 1. Check platen temperature at the center of platen (with conveyor belt wrap, conveyor belt, tensioners and release sheet removed). Use a pyrometer to confirm temperature readings. 2. After platen temperature reaches a maximum of 559°- 561°F (292°- 293°C) and auxiliary heaters reach a maximum of 339°- 341°F (170°- 172°C), and the temperature begins to drop, the heat indicator light on the temperature control board should turn on. If test readings do not agree with these figures, replace temperature display control.
	<p>To check platen:</p> <p>Use an Ohm meter to test resistance of the platen heater (disconnect 1 wire to isolate heater). Correct cold resistance for heating element of platen is 17.81 Ohms at 208V/2550 Watts. The auxiliary heaters are 108.2 Ohms at 208V/400 Watts.</p>	

VERTICAL CONTACT TOASTER



Problem	Possible Cause	Corrective Action
Product is over-toasted or platen heat is too high or drop time is too slow. (continued).	Defective drive motor or wrong drive motor.	To check drive motor: 1. Measure resistance of motor coil. Replace motor if coil measures either open circuit or zero resistance. 2. Mark the drive motor sprocket and count the turns per minute. Correct drive motor speed is nine (9) turns per minute.
	Defective drive chain or loose sprocket.	Check drive chain for kinks, broken or bent links or other damage. Check motor sprocket and drive sprockets (on drive shaft); tighten setscrew on flat of shaft if required. Check for damaged/worn sprockets and replace as required.
	Wiring problem.	Check all electrical connections for burns, discoloration or arcing. Replace all connections or components with damaged terminals. Replace all damaged wiring with the same (or higher) rated wire.
	Conveyor belt too loose.	Remove conveyor belt (page 13). Replace entire belt if links are damaged. If conveyor belt has too much play, it will jam. Adjust belt length as described under Servicing the Conveyor Belt (page 13).
Product is under toasted or platen heat is too low or drop time is too fast.	Bun adjustment controls set incorrectly.	Measure bun thickness and set bun adjustment controls correctly (page 7).
	Not enough voltage, defective power cord, defective rocker switch.	Confirm platen temperature reading with a pyrometer or other temperature source. Check receptacle for correct voltage. See Specifications (page 4). With unit plugged in and rocker switch on, check for correct voltage into rocker switch. If low or zero voltage, replace power cord. If voltage is correct, check for correct voltage out of rocker switch. If low or no voltage, replace rocker switch.
	Wiring problem.	Check all electrical connections for burns, discoloration or arcing. Replace all connections or components with damaged terminals. Replace all damaged wiring with the same (or higher) rated wire.

Problem	Possible Cause	Corrective Action
Product is under-toasted or platen heat is too low or drop time is too fast (continued).	Temperature display control or platen inoperative.	<p>To check temperature display control, allow unit to warm up for 30 minutes, then:</p> <ol style="list-style-type: none"> 1. Check platen temperature at the center of platen (with conveyor belt wrap, conveyor belt, tensioners and release sheet removed). Use a pyrometer to confirm temperature readings. 2. After platen temperature reaches a maximum of 559° -561°F (292° - 293°C) and auxiliary heaters reach a maximum of 339° - 341°F (170° - 172°C), and the temperature begins to drop, the heat indicator light on the temperature control board should turn on. If test readings do not agree with these figures, replace temperature display control. <p>To check platen:</p> <p>Use an Ohm meter to test resistance of the platen heater (disconnect 1 wire to isolate heater). Correct cold resistance for heating element of platen is 17.81 Ohms at 208V/2550 Watts. The auxiliary heaters are 108.2 Ohms at 208V/400 Watts.</p>
	Conveyor drive motor inoperative or incorrect conveyor motor installed in toaster.	<p>To check drive motor:</p> <ol style="list-style-type: none"> 1. Measure resistance of motor coil. Replace motor if coil measures either open circuit or zero resistance. 2. Mark the drive motor sprocket and count the turns per minute. Correct drive motor speed is nine (9) turns per minute.
Product is getting stuck or conveyor belts stop when product is toasting.	Bun adjustment controls set <u>incorrectly.</u>	Measure bun thickness and set bun adjustment controls correctly (page 8).
	Conveyor belt wrap missing or not installed properly.	Install conveyor belt wrap properly (page 13).
	Conveyor belt wrap or release sheet not clean.	Clean respective items. Refer to Maintenance Schedule (page 11)
	Not enough voltage, defective power cord or rocker switch.	<p>Check receptacle for correct voltage. See Specifications (page 4).</p> <p>With unit plugged in and rocker switch on, check for correct voltage into rocker switch. If low or zero voltage, replace power cord. If voltage is correct, check for correct voltage out of rocker switch. If low or no voltage, replace rocker switch.</p>

VERTICAL CONTACT TOASTER



Problem	Possible Cause	Corrective Action
Product is getting stuck or conveyor belts stop when product is toasting. (continued).	Wiring problem.	Check all electrical connections for burns, discoloration or arcing. Replace all connections or components with damaged terminals. Replace all damaged wiring with the same (or higher) rated wire.
	Conveyor drive motor inoperative or incorrect conveyor motor installed on toaster.	To check drive motor: 1. Measure resistance of motor coil. Replace motor if coil measures either open circuit or zero resistance. 2. Mark the drive motor sprocket and count the turns per minute. Correct drive motor speed is nine (9) turns per minute.
	Conveyor drive chain loose, worn or broken. Loose motor drive sprocket.	Check drive chain for kinks, broken or bent links or other damage. Check motor sprocket and drive sprockets (on drive shaft); tighten setscrew on flat of shaft if required. Check for damaged/worn sprockets and replace as required.
	Conveyor belts installed incorrectly.	Install conveyor belt to match diagram in Fig. 17 (page 13). Be sure that ends of the hooks are facing down.
Conveyor belts are "jumping" or "snapping".	Bent links within conveyor belt.	Remove and straighten bent links or replace entire conveyor belt.
	Conveyor drive sprocket(s) out of alignment.	Realign sprocket(s).
	Conveyor drive motor inoperative.	To check drive motor: 1. Measure resistance of motor coil. Replace motor if coil measures either open circuit or zero resistance. 2. Mark the drive motor sprocket and count the turns per minute. Correct drive motor speed is nine (9) turns per minute.
	Conveyor drive chain loose, worn or broken. Loose motor drive sprocket.	Check drive chain for kinks, broken or bent links or other damage. Check motor sprocket and drive sprockets (on drive shaft); tighten setscrew on flat of shaft if required. Check for damaged/worn sprockets and replace as required.

Problem	Possible Cause	Corrective Action
Conveyor belts are "jumping" or "snapping". (continued).	Conveyor belts installed incorrectly.	Install conveyor belt to match diagram in Fig. 17 (page 13). Be sure that ends of the hooks are facing down.
	Conveyor belt too loose (40 links required when new). When new, conveyor has 38 large links and 2 small links.	Remove conveyor belt (page 13). Lay belt flat and count links. Replace entire belt if links are damaged. If conveyor belt has too much play, it will jam. Adjust belt length as described under Servicing the Conveyor Belt (page 13).
	Roller tensioner assy(s). bent or missing.	Replace roller tensioner assy(s). (29, page 26) or tensioners (4, page 30) if damaged or loose. Replace slide rails (40, page 30) if worn or missing.
Temperature display flashes "LO".	Platen temperature is below 420°F (216°C).	Allow 20 minutes for warm-up and recheck display.
	Defective solid state relay.	Replace solid state relay.
	Heater Platen is "OPEN".	To check platen: Use an Ohm meter to test resistance of the platen heater (disconnect 1 wire to isolate heater). Correct cold resistance for heating element of platen is 17.81 Ohms at 208V/2550 Watts. The auxiliary heaters are 108.2 Ohms at 208V/400 Watts.
	Faulty control board.	Replace control board.
Temperature display flashes "HI".	Platen thermocouple is disconnected or open.	Reattach or replace platen thermocouple.
	Defective solid state relay.	Replace solid state relay.
	Platen temperature is over 591°F (310°C).	See Fault Messages (pages 10 & 11).
	Defective control board.	Replace control board.

VERTICAL CONTACT TOASTER



Problem	Possible Cause	Corrective Action
Temperature display shows "PO".	Unit is receiving low voltage, below 190 VAC.	Turn rocker switch off, then on. If display shows "PO" again, check power cord, power cord plug and receptacle for damage. Replace as required.
Crown and/or heel must be forced into toaster.	Heat shield improperly installed or damaged.	Remove and reposition heat shield or replace it.
	Conveyor belt wrap not tacky.	Clean or replace conveyor belt wrap.
	Crown and/or heel improperly inserted into toaster.	Buns must be inserted with cut faces facing each other; heel in front slot and crown in rear slot.
	Release sheet is sticky and not smooth.	Clean or replace release sheet.
Conveyor belt wrap does not fit, is difficult to install or is not long enough.	Conveyor belt wrap is installed improperly.	Check to be sure conveyor belt wrap is not placed over upper support rod. Be sure the open end of the flap is away from direction and rotation, and is located toward the outside of the conveyor belt wrap.
	Conveyor belt wrap is damaged.	Replace conveyor belt wrap.
Temperature display flashes "HI" and "LO" at cold start-up.	Auxiliary thermocouple is disconnected or "Open".	Reattach or replace auxiliary thermocouple.
	Faulty control board.	Replace control board.
Temperature display flashes "HI" and the platen setpoint temperature.	Auxiliary thermocouple is disconnected or "Open".	Reattach or replace auxiliary thermocouple.
	Faulty control board.	Replace control board.
	Faulty auxiliary solid state relay.	Replace solid state relay.

WIRING DIAGRAMS

Pictorial Wiring Diagram

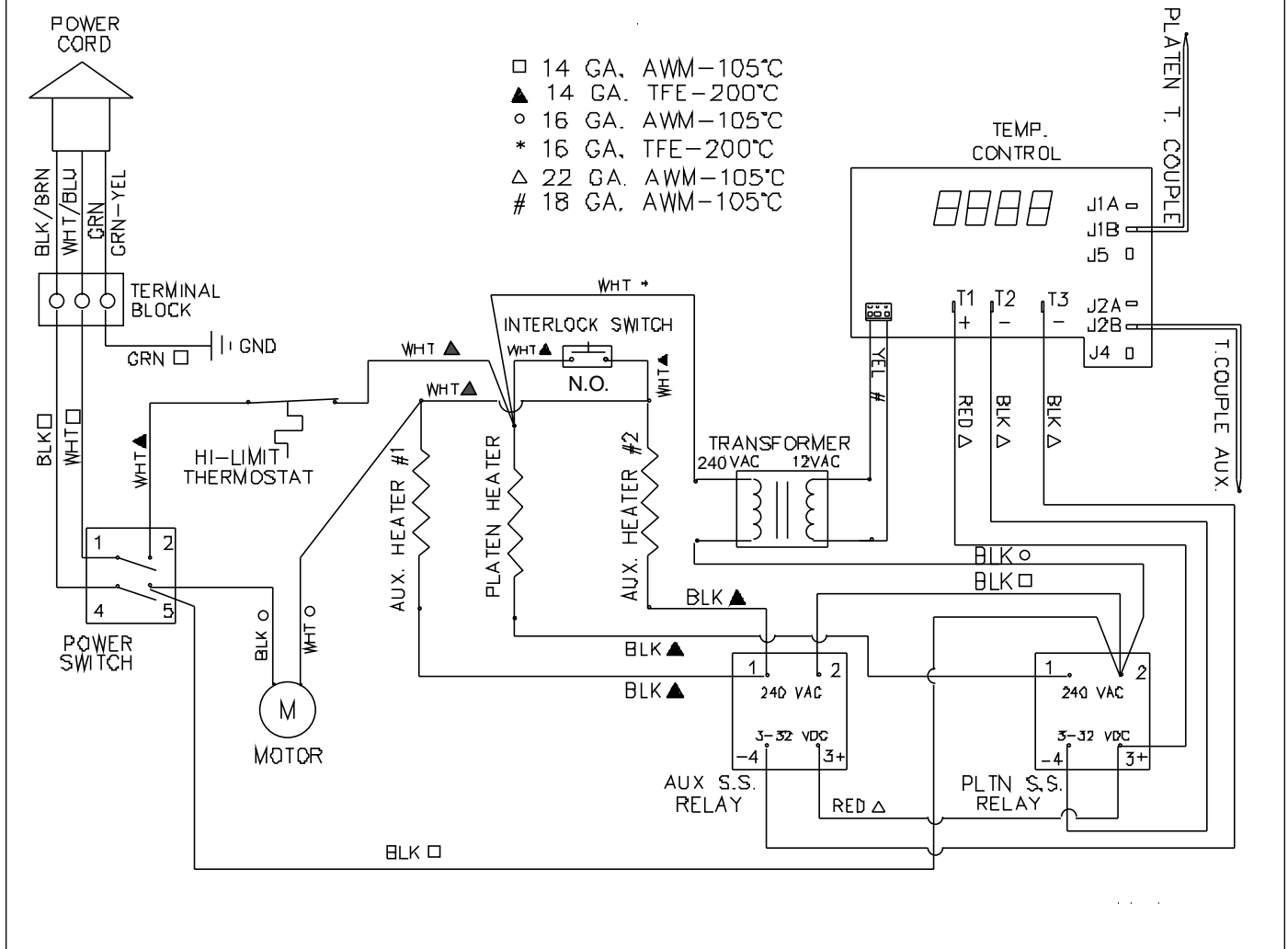

WIRING DIAGRAMS (continued)

Ladder Wiring Diagram

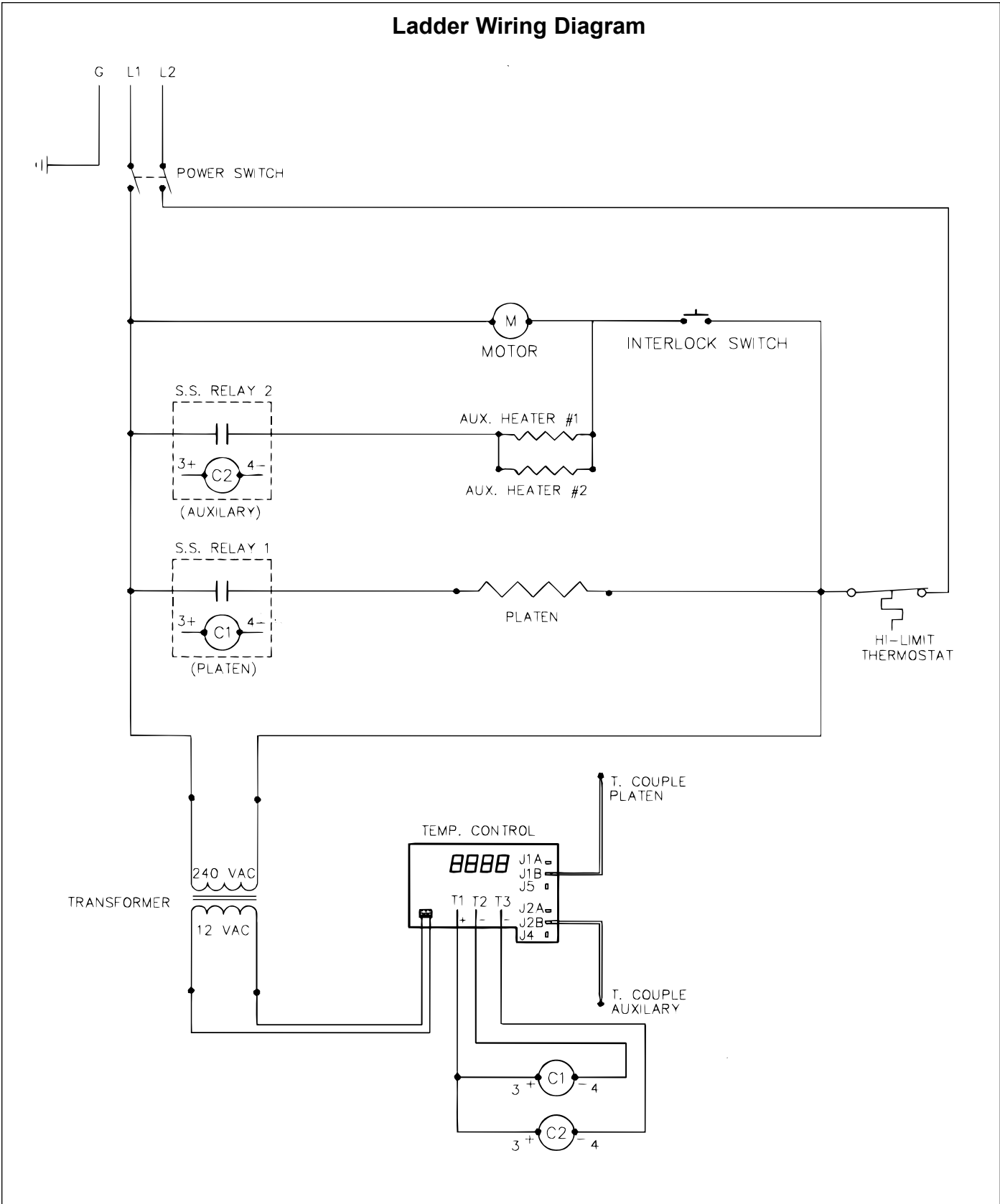

REPLACEMENT PARTS

Parts Identification

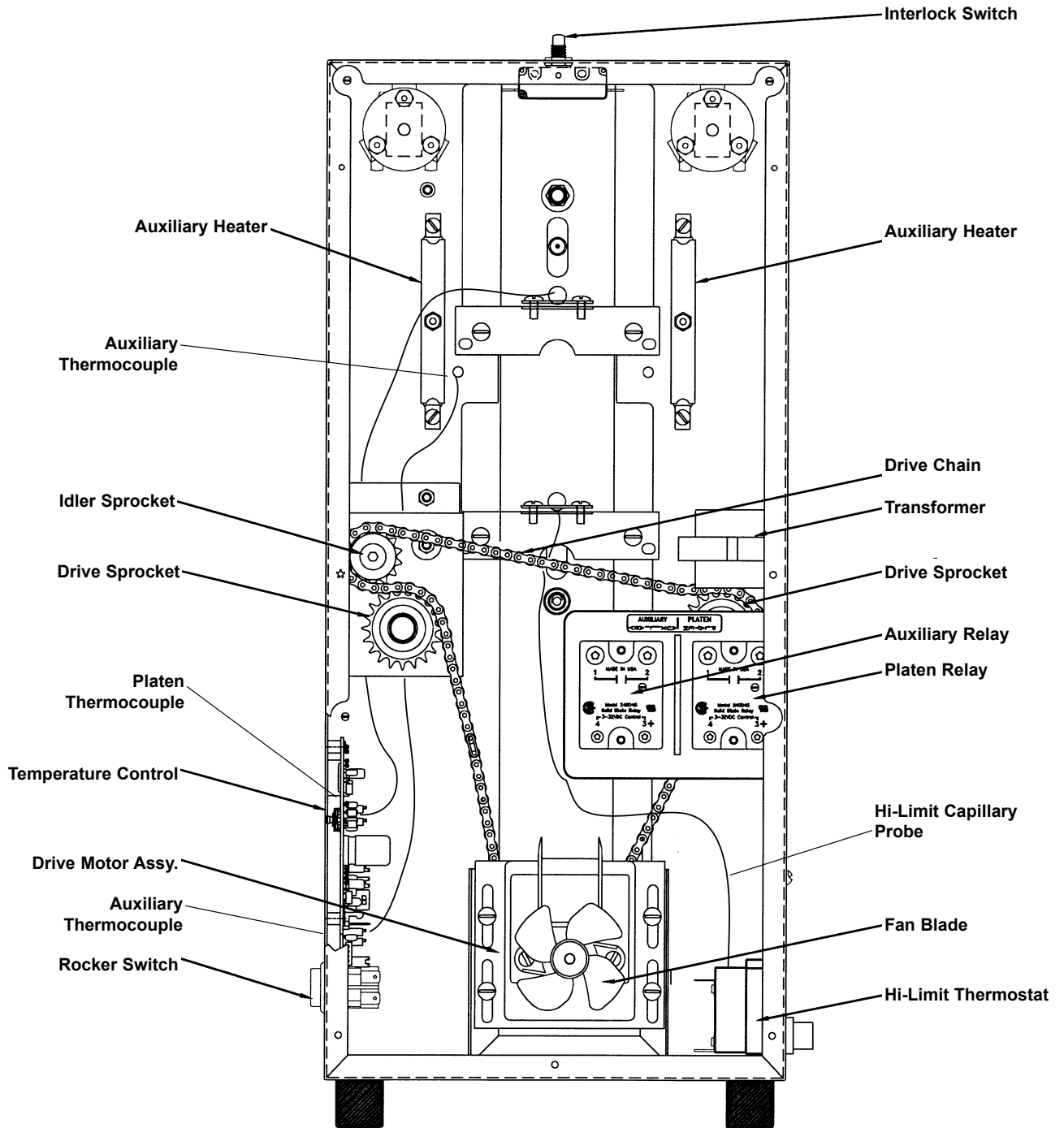

REPLACEMENT PARTS (continued)

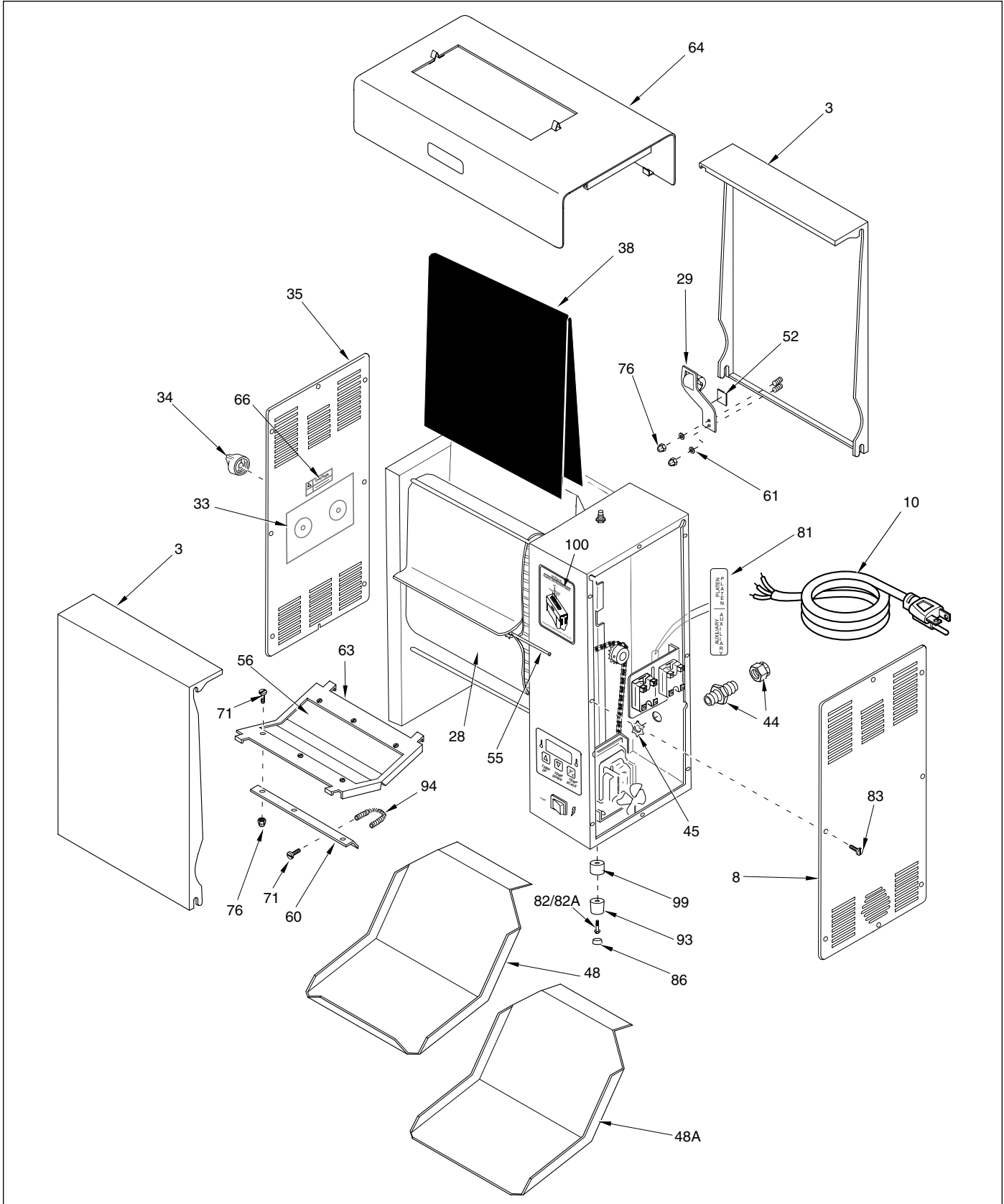

Item	Part No.	Description	Qty.
1	0011264	Conveyor Belt	2
	0800204	1/2" Pitch Link, Small	4
	0800121	3/4" Pitch Link, Large	37
2	2150117	Idler Shaft	2
3	0011329	Conveyor Cover Assy.	2
4	0010475	Tensioner Assy. (Incl. #40, 76, 85)	4
5	0800332	Rod, Conveyor Cover	4
6	2150190	Sprocket	8
7	7000199*	Spacer Kit	2
8	0503362	Control Cover	1
9	2150118	Drive Shaft	2
10	0700452	Power Cord/Plug, NEMA 6-20P (Std.)	1
	0700588	Power Cord/Plug, HRN/IEC-309	1
11	7000739	Control Board Kit	1
12	2150158	Ball Bearing	2
13	2150186	Bearing	6
14	0503459	Bearing Retainer/Spacer	6
15	0503376	Bearing Retainer	6
16	7000167	Bearing & Retainer Kit (Includes #13, 14, 15 & 59)	1
17	2150181	Drive Sprocket	2
18	2150187	Drive Chain	1
19	0011299	Idler Sprocket & Bearing	1
20	0501232	Bracket, Idler Sprocket	1
21	0503589	Bracket, Motor Mounting	1
22	7000175	Drive Motor Kit, 60 Hz (Incl. #58)	1
	7000240	Drive Motor Kit, Dual Frequency 50/60 Hz (Incl. #58)	1
23	2150173	Sprocket w/Setscrew, Motor	1
24	7000882	Rocker Switch Kit	1
25	4060355	Terminal Block	1
26	405K125	Relay, Solid State	2
27	4010187	Transformer	1
28	7000192	Conveyor Belt Wrap (Pack of 2)	1
29	7000186	Roller Tensioner Assy. (Pack of 2)	1
30	0503496	Tensioner Bracket, Right	2
31	0503497	Tensioner Bracket, Left	2
32	1001037	Label, Control	1
33	10P1047*	Label, Dial (Pack of 10)	1
34	2100253	Knob, Control	2
35	0503390	Cover, End Housing	1
36	4050214	Thermocouple Assy.	1
37	0021170	Weldment, End Housing	1
38	7000110	Release Sheet (Pack of 3)	-
	7000111	Release Sheet (Pack of 10)	-
39	0021169	Control Housing	1
40	7000121	Slide Rail Kit (Includes 2 slide rails for tensioners)	2
41	0021207	Conveyor Cam	2
42	7000176	Thermocouple Retainer Kit	2
43	4030332	High Limit Thermostat	1
44	040K251	Strain Relief	1
	0400315	Strain Relief (9200552 only)	1
45	0400138	Locknut, 1/2"	1
46	0503590	Bracket, Motor	1
47	0700580	Wire Set (not shown)	1
48	0503385	Bun Chute	1
48A	0503677	Bun Chute (9200650 Only)	1

Item	Part No.	Description	Qty.
49	4030333	Auxiliary Heater, Air, 400 Watts	2
50	7000165	Auxiliary Thermocouple Kit	1
51	7000200	Platen (208 VOLT)	1
52	2100252	Tape	4
53	0503359	Bracket, Relay	1
54	0503150	Heater Clip	2
55	303P125*	Hinge Pin, Belt Wrap	2
56	0400312	Damper	2
57	0503533	Bracket, Auxiliary Thermocouple	1
58	4000165	Fan Blade, Motor	1
59	2100256	Tape	8
60	0011301	Damper Support Assy.	2
61	0502199	Spacer	4
62	0500464	Retainer, Bearing	1
63	0011321	Damper Assy.	1
64	0011330	Heat Shield Assy.	1
65	325P163*	Setscrew, 1/4-28 x 5/16"	8
66	100P864*	Label, Caution Hot	1
67	308P115*	Screw, #8-32 x 3/8" (10 mm)	2
68	304P105*	Nut, #4-40, "KEPS"	4
69	406P107*	Cable Tie	1
70	308P143*	Nut, #8-32, "KEPS"	6
71	310P154*	Screw, #10-32 x 3/8"	4
72	310P140*	Washer, #10	6
73	308P101*	Nut, #8-32	3
74	306P101*	Nut, Hex, #6-32	2
75	306P123*	Screw, #6-32 x 7/8"	2
76	308P145*	Nut, Hex Acorn, #8-32	14
77	100P900*	Label, Service	1
78	325P104*	Washer, 1/4"	4
79	325P109*	Screw, 1/4-20 x 1/2"	4
80	308P124*	Screw, 1-Way, #8-32 x 1/2"	1
81	10P1022*	Label, Heaters	1
82	310P136*	Screw, #10-32 x 1-1/4"	4
82A	310P180*	Screw, #10-32 x 1-3/4 (9200650 Only)	1
83	308P133*	Screw, #8-32 x 1/4"	1
84	308P151*	Screw, SEMS, #8-32 x 5/16"	4
85	308P181*	Screw, Flat Hd., #8-32 x 3/8"	4
86	218P145*	Cover, Leg, Bumper	4
87	331P103*	Shoulder Bolt, 5/16-18 x 1"	1
88	306P105*	Screw, #6-32 x 1/2"	1
89	331P106*	Lockwasher, 5/16"	1
90	212P118*	Flat Washer, 5/16"	1
91	331P101*	Nut, Hex, 5/16 x 18"	1
92	300P102*	Nut, Tinnerman	2
93	210P230	Bumper, Recess Leg, 1"	4
94	0600132	Spring, Damper Support	4
95	4010107	Interlock Switch	1
96	306P104*	Screw, #6-32 x 1/4"	8
97	0503495	Retainer, Tensioner Bracket, RH	1
98	0503507	Retainer, Tensioner Bracket, LH	1
99	2120147	Spacer, Leg (9200650 Only)	4
100	1001056	Label, Crown and Heel (9200650 Only)	1
101	2100259	Slide Bar	4
102	0503455	Tension Spring, Inner	4

* Only available in packages of 10.

REPLACEMENT PARTS (continued)

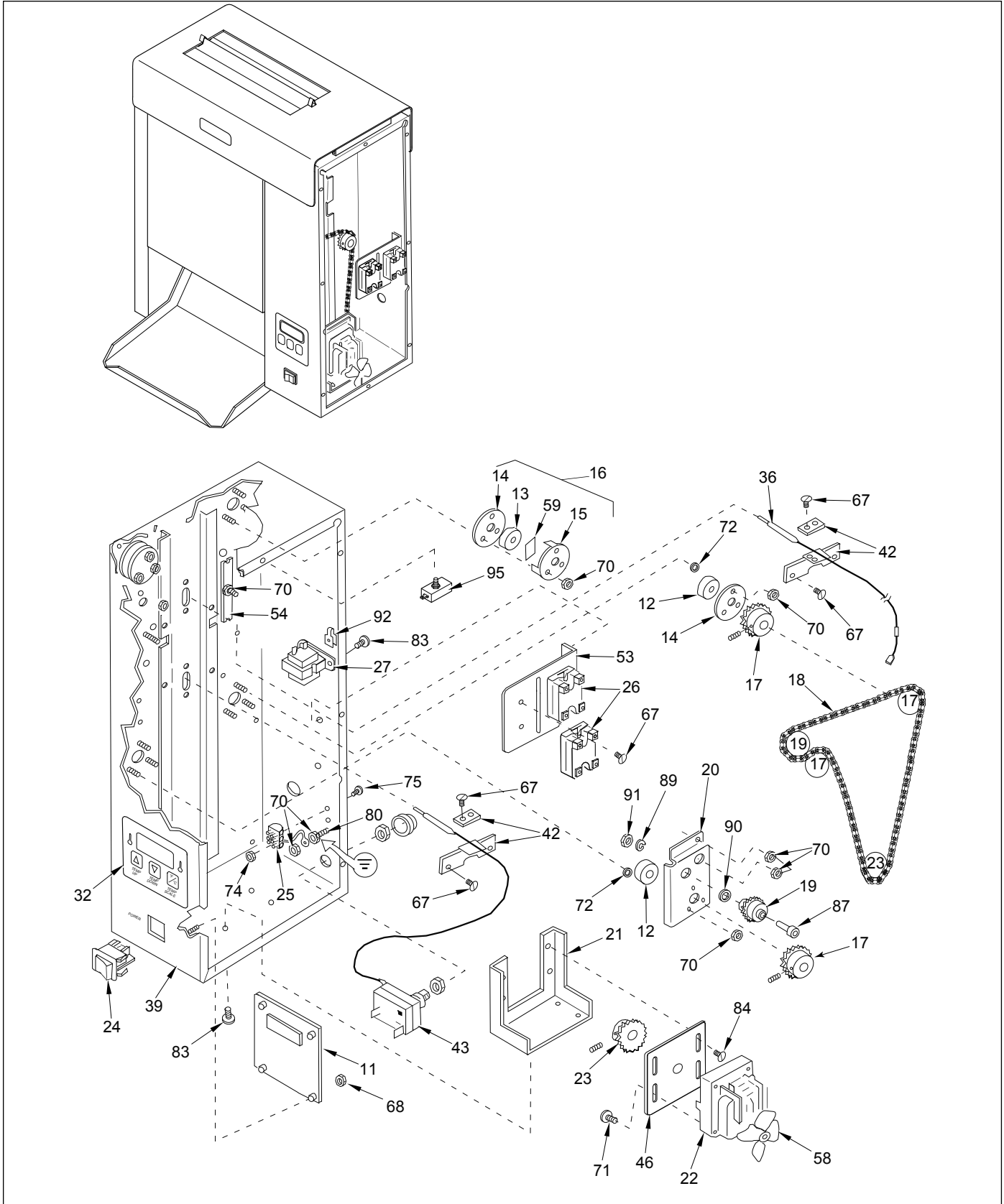

Item	Part No.	Description	Qty.
1	0011264	Conveyor Belt	2
	0800204	1/2" Pitch Link, Small	4
	0800121	3/4" Pitch Link, Large	37
2	2150117	Idler Shaft	2
3	0011329	Conveyor Cover Assy.	2
4	0010475	Tensioner Assy. (Incl. #40, 76, 85)	4
5	0800332	Rod, Conveyor Cover	4
6	2150190	Sprocket	8
7	7000199*	Spacer Kit	2
8	0503362	Control Cover	1
9	2150118	Drive Shaft	2
10	0700452	Power Cord/Plug, NEMA 6-20P (Std.)	1
	0700588	Power Cord/Plug, HRN/IEC-309	1
11	7000198	Control Board	1
12	2150158	Ball Bearing	2
13	2150186	Bearing	6
14	0503459	Bearing Retainer/Spacer	6
15	0503376	Bearing Retainer	6
16	7000167	Bearing & Retainer Kit (Includes #13, 14, 15 & 59)	1
17	2150181	Drive Sprocket	2
18	2150187	Drive Chain	1
19	0011299	Idler Sprocket & Bearing	1
20	0501232	Bracket, Idler Sprocket	1
21	0503589	Bracket, Motor Mounting	1
22	7000175	Drive Motor Kit, 60 Hz (Incl. #58)	1
	7000240	Drive Motor Kit, Dual Frequency 50/60 Hz (Incl. #58)	1
23	2150173	Sprocket w/Setscrew, Motor	1
24	4010137	Rocker Switch, On/Off (250 VAC)	1
25	4060355	Terminal Block	1
26	405K125	Relay, Solid State	2
27	4010187	Transformer	1
28	7000192	Conveyor Belt Wrap (Pack of 2)	1
29	7000186	Roller Tensioner Assy. (Pack of 2)	1
30	0503496	Tensioner Bracket, Right	2
31	0503497	Tensioner Bracket, Left	2
32	1001037	Label, Control	1
33	10P1047*	Label, Dial (Pack of 10)	1
34	2100253	Knob, Control	2
35	0503390	Cover, End Housing	1
36	4050214	Thermocouple Assy.	1
37	0021170	Weldment, End Housing	1
38	7000110	Release Sheet (Pack of 3)	-
	7000111	Release Sheet (Pack of 10)	-
39	0021169	Control Housing	1
40	7000121	Slide Rail Kit (Includes 2 slide rails for tensioners)	2
41	0021207	Conveyor Cam	2
42	7000176	Thermocouple Retainer Kit	2
43	4030332	High Limit Thermostat	1
44	040K251	Strain Relief	1
	0400315	Strain Relief (9200552 only)	1
45	0400138	Locknut, 1/2"	1
46	0503590	Bracket, Motor	1
47	0700580	Wire Set (not shown)	1
48	0503385	Bun Chute	1
48A	0503677	Bun Chute (9200650 Only)	1

Item	Part No.	Description	Qty.
49	4030333	Auxiliary Heater, Air, 400 Watts	2
50	7000165	Auxiliary Thermocouple Kit	1
51	7000200	Platen (208 VOLT)	1
52	2100252	Tape	4
53	0503359	Bracket, Relay	1
54	0503150	Heater Clip	2
55	303P125*	Hinge Pin, Belt Wrap	2
56	0400312	Damper	2
57	0503533	Bracket, Auxiliary Thermocouple	1
58	4000165	Fan Blade, Motor	1
59	2100256	Tape	8
60	0011301	Damper Support Assy.	2
61	0502199	Spacer	4
62	0500464	Retainer, Bearing	1
63	0011321	Damper Assy.	1
64	0011330	Heat Shield Assy.	1
65	325P163*	Setscrew, 1/4-28 x 5/16"	8
66	100P864*	Label, Caution Hot	1
67	308P115*	Screw, #8-32 x 3/8" (10 mm)	2
68	304P105*	Nut, #4-40, "KEPS"	4
69	406P107*	Cable Tie	1
70	308P143*	Nut, #8-32, "KEPS"	6
71	310P154*	Screw, #10-32 x 3/8"	4
72	310P140*	Washer, #10	6
73	308P101*	Nut, #8-32	3
74	306P101*	Nut, Hex, #6-32	2
75	306P123*	Screw, #6-32 x 7/8"	2
76	308P145*	Nut, Hex Acorn, #8-32	14
77	100P900*	Label, Service	1
78	325P104*	Washer, 1/4"	4
79	325P109*	Screw, 1/4-20 x 1/2"	4
80	308P124*	Screw, 1-Way, #8-32 x 1/2"	1
81	10P1022*	Label, Heaters	1
82	310P136*	Screw, #10-32 x 1-1/4"	4
82A	310P180*	Screw, #10-32 x 1-3/4 (9200650 Only)	1
83	308P133*	Screw, #8-32 x 1/4"	1
84	308P151*	Screw, SEMS, #8-32 x 5/16"	4
85	308P181*	Screw, Flat Hd., #8-32 x 3/8"	4
86	218P145*	Cover, Leg, Bumper	4
87	331P103*	Shoulder Bolt, 5/16-18 x 1"	1
88	306P105*	Screw, #6-32 x 1/2"	1
89	331P106*	Lockwasher, 5/16"	1
90	212P118*	Flat Washer, 5/16"	1
91	331P101*	Nut, Hex, 5/16 x 18"	1
92	300P102*	Nut, Tinnerman	2
93	210P230	Bumper, Recess Leg, 1"	4
94	0600132	Spring, Damper Support	4
95	4010107	Interlock Switch	1
96	306P104*	Screw, #6-32 x 1/4"	8
97	0503495	Retainer, Tensioner Bracket, RH	1
98	0503507	Retainer, Tensioner Bracket, LH	1
99	2120147	Spacer, Leg (9200650 Only)	4
100	1001056	Label, Crown and Heel (9200650 Only)	1
101	2100259	Slide Bar	4
102	0503455	Tension Spring, Inner	4

* Only available in packages of 10.

REPLACEMENT PARTS (continued)

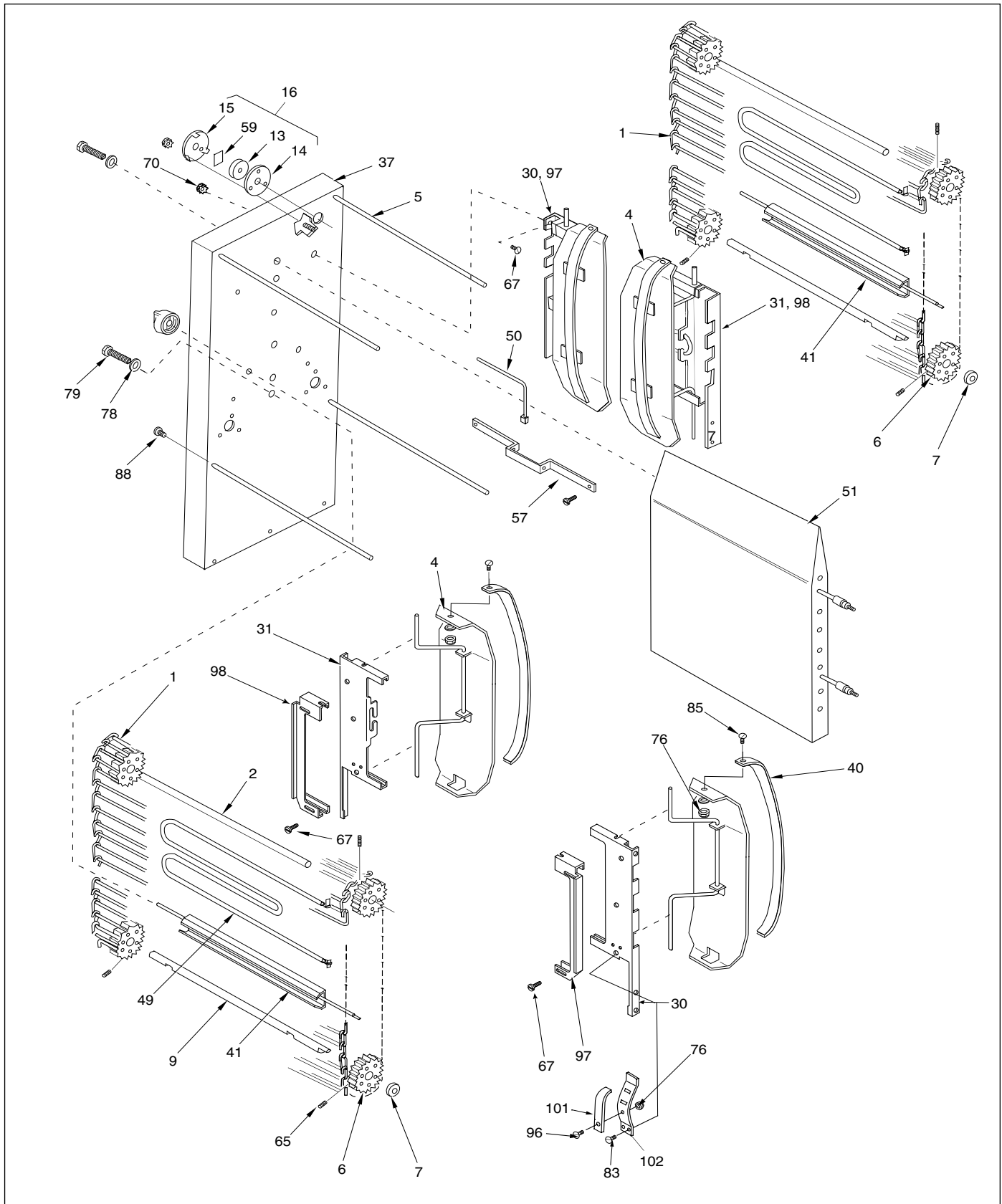

Item	Part No.	Description	Qty.
1	0011264	Conveyor Belt	2
	0800204	1/2" Pitch Link, Small	4
	0800121	3/4" Pitch Link, Large	37
2	2150117	Idler Shaft	2
3	0011329	Conveyor Cover Assy.	2
4	0010475	Tensioner Assy. (Incl. #40, 76, 85)	4
5	0800332	Rod, Conveyor Cover	4
6	2150190	Sprocket	8
7	7000199*	Spacer Kit	2
8	0503362	Control Cover	1
9	2150118	Drive Shaft	2
10	0700452	Power Cord/Plug, NEMA 6-20P (Std.)	1
	0700588	Power Cord/Plug, HRN/IEC-309	1
11	7000198	Control Board	1
12	2150158	Ball Bearing	2
13	2150186	Bearing	6
14	0503459	Bearing Retainer/Spacer	6
15	0503376	Bearing Retainer	6
16	7000167	Bearing & Retainer Kit (Includes #13, 14, 15 & 59)	1
17	2150181	Drive Sprocket	2
18	2150187	Drive Chain	1
19	0011299	Idler Sprocket & Bearing	1
20	0501232	Bracket, Idler Sprocket	1
21	0503589	Bracket, Motor Mounting	1
22	7000175	Drive Motor Kit, 60 Hz (Incl. #58)	1
	7000240	Drive Motor Kit, Dual Frequency 50/60 Hz (Incl. #58)	1
23	2150173	Sprocket w/Setscrew, Motor	1
24	4010137	Rocker Switch, On/Off (250 VAC)	1
25	4060355	Terminal Block	1
26	405K125	Relay, Solid State	2
27	4010187	Transformer	1
28	7000192	Conveyor Belt Wrap (Pack of 2)	1
29	7000186	Roller Tensioner Assy. (Pack of 2)	1
30	0503496	Tensioner Bracket, Right	2
31	0503497	Tensioner Bracket, Left	2
32	1001037	Label, Control	1
33	10P1047*	Label, Dial (Pack of 10)	1
34	2100253	Knob, Control	2
35	0503390	Cover, End Housing	1
36	4050214	Thermocouple Assy.	1
37	0021170	Weldment, End Housing	1
38	7000110	Release Sheet (Pack of 3)	-
	7000111	Release Sheet (Pack of 10)	-
39	0021169	Control Housing	1
40	7000121	Slide Rail Kit (Includes 2 slide rails for tensioners)	2
41	0021207	Conveyor Cam	2
42	7000176	Thermocouple Retainer Kit	2
43	4030332	High Limit Thermostat	1
44	040K251	Strain Relief	1
	0400315	Strain Relief (9200552 only)	1
45	0400138	Locknut, 1/2"	1
46	0503590	Bracket, Motor	1
47	0700580	Wire Set (not shown)	1
48	0503385	Bun Chute	1
48A	0503677	Bun Chute (9200650 Only)	1

Item	Part No.	Description	Qty.
49	4030333	Auxiliary Heater, Air, 400 Watts	2
50	7000165	Auxiliary Thermocouple Kit	1
51	7000200	Platen (208 VOLT)	1
52	2100252	Tape	4
53	0503359	Bracket, Relay	1
54	0503150	Heater Clip	2
55	303P125*	Hinge Pin, Belt Wrap	2
56	0400312	Damper	2
57	0503533	Bracket, Auxiliary Thermocouple	1
58	4000165	Fan Blade, Motor	1
59	2100256	Tape	8
60	0011301	Damper Support Assy.	2
61	0502199	Spacer	4
62	0500464	Retainer, Bearing	1
63	0011321	Damper Assy.	1
64	0011330	Heat Shield Assy.	1
65	325P163*	Setscrew, 1/4-28 x 5/16"	8
66	100P864*	Label, Caution Hot	1
67	308P115*	Screw, #8-32 x 3/8" (10 mm)	2
68	304P105*	Nut, #4-40, "KEPS"	4
69	406P107*	Cable Tie	1
70	308P143*	Nut, #8-32, "KEPS"	6
71	310P154*	Screw, #10-32 x 3/8"	4
72	310P140*	Washer, #10	6
73	308P101*	Nut, #8-32	3
74	306P101*	Nut, Hex, #6-32	2
75	306P123*	Screw, #6-32 x 7/8"	2
76	308P145*	Nut, Hex Acorn, #8-32	14
77	100P900*	Label, Service	1
78	325P104*	Washer, 1/4"	4
79	325P109*	Screw, 1/4-20 x 1/2"	4
80	308P124*	Screw, 1-Way, #8-32 x 1/2"	1
81	10P1022*	Label, Heaters	1
82	310P136*	Screw, #10-32 x 1-1/4"	4
82A	310P180*	Screw, #10-32 x 1-3/4 (9200650 Only)	1
83	308P133*	Screw, #8-32 x 1/4"	1
84	308P151*	Screw, SEMS, #8-32 x 5/16"	4
85	308P181*	Screw, Flat Hd., #8-32 x 3/8"	4
86	218P145*	Cover, Leg, Bumper	4
87	331P103*	Shoulder Bolt, 5/16-18 x 1"	1
88	306P105*	Screw, #6-32 x 1/2"	1
89	331P106*	Lockwasher, 5/16"	1
90	212P118*	Flat Washer, 5/16"	1
91	331P101*	Nut, Hex, 5/16 x 18"	1
92	300P102*	Nut, Tinnerman	2
93	210P230	Bumper, Recess Leg, 1"	4
94	0600132	Spring, Damper Support	4
95	4010107	Interlock Switch	1
96	306P104*	Screw, #6-32 x 1/4"	8
97	0503495	Retainer, Tensioner Bracket, RH	1
98	0503507	Retainer, Tensioner Bracket, LH	1
99	2120147	Spacer, Leg (9200650 Only)	4
100	1001056	Label, Crown and Heel (9200650 Only)	1
101	2100259	Slide Bar	4
102	0503455	Tension Spring, Inner	4

* Only available in packages of 10.

Limited Warranty

Equipment manufactured by Roundup Food Equipment Division of A.J. Antunes & Co. has been constructed of the finest materials available and manufactured to high quality standards. These units are warranted to be free from electrical and mechanical defects for a period of one (1) year from date of purchase under normal use and service, and when installed in accordance with manufacturer's recommendations. To insure continued operation of the units, follow the maintenance procedures outlined in the Owner's Manual. During the first 12 months, electro-mechanical parts, non-overtime labor, and travel expenses up to 2 hours (100 miles/160 km), round trip from the nearest Authorized Service Center are covered.

1. This warranty does not cover cost of installation, defects caused by improper storage or handling prior to placing of the Equipment. This warranty does not cover overtime charges or work done by unauthorized service agencies or personnel. This warranty does not cover normal maintenance, calibration, or regular adjustments as specified in operating and maintenance instructions of this manual, and/or labor involved in moving adjacent objects to gain access to the equipment. This warranty does not cover consumable/wear items. This warranty does not cover damage to the Load Cell or Load Cell Assembly due to abuse, misuse, dropping of unit/shock loads or exceeding maximum weight capacity (4 lbs). This warranty does not cover water contamination problems such as foreign material in water lines or inside solenoid valves. It does not cover water pressure problems or failures resulting from improper/incorrect voltage supply. This warranty does not cover Travel Time & Mileage in excess of 2 hours (100 miles/160 km) round trip from the nearest authorized service agency.
2. Roundup reserves the right to make changes in design or add any improvements on any product. The right is always reserved to modify equipment because of factors beyond our control and government regulations. Changes to update equipment do not constitute a warranty charge.
3. If shipment is damaged in transit, the purchaser should make a claim directly upon the carrier. Careful inspection should be made of the shipment as soon as it arrives and visible damage should be noted upon the carrier's receipt. Damage should be reported to the carrier. This damage is not covered under this warranty.
4. Warranty charges do not include freight or foreign, excise, municipal or other sales or use taxes. All such freight and taxes are the responsibility of the purchaser.
5. THIS WARRANTY IS EXCLUSIVE AND IS IN LIEU OF ALL OTHER WARRANTIES, EXPRESSED OR IMPLIED, INCLUDING ANY IMPLIED WARRANTY OR MERCHANTABILITY OR FITNESS FOR A PARTICULAR PURPOSE, EACH OF WHICH IS HEREBY EXPRESSLY DISCLAIMED. THE REMEDIES DESCRIBED ABOVE ARE EXCLUSIVE AND IN NO EVENT SHALL ROUNDUP BE LIABLE FOR SPECIAL CONSEQUENTIAL OR INCIDENTAL DAMAGES FOR THE BREACH OR DELAY IN PERFORMANCE OF THIS WARRANTY.



A.J. Antunes & Co.
We exist to make our customers successful.

A.J. Antunes & Co.
Headquarters/Manufacturing
Carol Stream, Illinois 60188 USA
Phone: (630) 784-1000
Toll Free: (800) 253-2991
Fax: (630) 784-1650

Antunes Equipment
Manufacturing (Suzhou) Ltd.,
Suzhou, Jiangsu, China 215011
Phone: 86-512-6841-3637
Toll Free: 400-0-7878-22
Fax: 86-512-6841-3907

www.ajantunes.com