

Water Filtration System

Model VZN-441 VA owner's manual

Manufacturing Numbers:

9700776



Cartridge Tested and Certified by NSF International against NSF/ANSI Standard 42 and 53 for the reduction of:

Standard No. 42: Aesthetic Effects
Nominal Particulate Reduction Class I

Standard No. 53: Health Effects
Cyst Reduction & Turbidity Reduction
as verified and substantiated by test data.

CONTENTS

General	2
Warranty Information	2
Service/Technical Assistance.....	2
Important Safety Information	3
Specifications.....	4
Performance Data Sheet	5
Installation	6
Operation	12
Maintenance	13
Troubleshooting	16
Replacement Parts.....	17
Notes.....	19

IMPORTANT

A.J. Antunes & Co. reserves the right to change specifications and product design without notice. Such revisions do not entitle the buyer to corresponding changes, improvements, additions or replacements for previously purchased equipment.

IMPORTANT

Keep these instructions for future reference. If the unit changes ownership, be sure this manual accompanies the equipment.

GENERAL

This manual provides the safety, installation, and operating procedures for the VZN water filtration system. All information contained in this manual should be read prior to installing and operating the system.

This system is manufactured from the finest materials available and is assembled to strict quality standards. This system has been tested at the factory to ensure dependable trouble-free operation.

WARRANTY INFORMATION

Please read the full text of the Limited Warranty in this manual.

If the system arrives damaged, contact the carrier immediately and file a damage claim with them. Save all packing materials when filing a claim. Freight damage claims are the responsibility of the purchaser and are not covered under warranty.

The warranty does NOT extend to:

- Damages caused in shipment or damage as result of improper use.
- Installation of electrical service.
- Normal maintenance as outlined in this manual.
- Malfunction resulting from improper maintenance.
- Damage from moisture leaking into electrical components.
- Damage from tampering with, removal of, or changing any pre-set control or safety device.

SERVICE/TECHNICAL ASSISTANCE

If you experience any problems with the installation or operation of your system, contact A.J. Antunes & Co. at 1-630-784-1000, or toll free in the United States at 1-800-253-2991.

Fill in the information in the next column and have it handy when calling for assistance. The serial number is on the specification plate located on the system.

Purchased From

Date of Purchase

Model Number

Serial Number

Mfg. Number

Suggested replacement period for the Ultra Filter Cartridge is approximately 3 years.

For sales in the state of Iowa:

Seller:

Date:

Buyer:

Date:

CAUTION

All electrical connections must be in accordance with local electrical codes and any other applicable codes. A ground fault circuit interrupter (GFCI) must be installed on the circuit to this system. When installed on metallic plumbing, a properly sized electrical bonding jumper must be installed across the inlet and outlet pipes serving this unit.

IMPORTANT

This equipment is to be installed to comply with the basic plumbing code of the Building Officials and Code Administrators, Inc. (BOCA) and the Food Service Sanitation Manual of the Food and Drug Administration (FDA).

IMPORTANT

Water Flow Regulator Assemblies are NOT interchangeable. Operating the system with the wrong Water Flow Regulator or without a regulator can damage the system, cause personal injury, and voids the warranty!

IMPORTANT SAFETY INFORMATION

In addition to the warnings and cautions in this manual, use the following guidelines to safely operate the system:

- Read all instructions before using equipment.
- Install or locate the equipment only for its intended use as described in this manual.
- Do NOT use corrosive chemicals in this equipment.
- Do NOT operate this equipment if it has a damaged cord or plug; if it is not working properly, or if it has been damaged or dropped.
- This equipment should be serviced by qualified personnel only. Contact A.J. Antunes & Co. for repair.
- Do NOT immerse cord or plug in water.
- Keep cord away from heated surfaces.
- This equipment should be supplied with only cold water.
- For installations in Massachusetts, the Commonwealth of Massachusetts Plumbing Code 248 CMR shall be adhered to. The use of saddle valves are not permitted. Please consult your local plumber.

The following warnings and cautions appear throughout this manual and should be carefully observed.

- Unplug the power cord before performing any service or maintenance on the unit.
- All electrical connections must be in accordance with local electrical codes and any other applicable codes.
- Warning electrical shock hazard. Failure to follow these instructions could result in serious injury or death.
- Do NOT modify the power supply cord plug. If it does not fit the outlet, have a proper outlet installed by a qualified electrician.
- Do NOT use an extension cord with this unit.
- If the supply cord is damaged, it must be replaced by the manufacturer, its service agent, or a similarly qualified person.
- This equipment is to be installed to comply with the local plumbing code and any other applicable code.

- Water pressure must not exceed 100 psig (690 kPa). To reduce water pressure, install a water pressure regulator and set to suit the application.
- The trans membrane pressure (inlet pressure minus the permeate water pressure) must not exceed 45 psi (310 kPa).
- A ground fault circuit interrupter (GFCI) must be installed on the circuit to this system.
- When installed on metallic plumbing, a properly sized electrical bonding jumper must be installed across the inlet and outlet pipes serving this unit.

NOTE: If the inlet water pressure is less than 50 psig (345 kPa), install a suitably sized booster system (outlet pressure 60 psig - 100 psig max (414 kPa - 690 kPa max).

Protect from becoming dry

If the membrane dries out, irreversible damage to the Ultra Filter membrane may result. Protect the filter from becoming dry by keeping it wet and sealed at all times.

Protect from freezing

If the Ultra Filter membrane freezes during operation or storage, irreversible damage to the membrane and brittle cracking of the cartridge or housing may result.

Protect from direct sunlight or other UV sources

Avoid long-term exposure to direct sunlight or other UV sources. The Ultra Filter should be stored in a dark location.

Protect from high temperatures or abrupt variation in temperature

The maximum operating temperature is 104°F (40°C). Avoid abrupt variations in temperature. Any temperature variation should be made slowly.

Protect from rough handling or dropping

Mechanical damage, external breakage, and/or internal breakage of the filter can result if the system is dropped or bumped. Handle with care at all times during transportation and installation.

Protect from organic solvents and concentrated acids

Prevent any and all contact of the membrane with strong solvents, solvents containing chlorine, or concentrated acids. Do NOT use strong solvents or concentrated acids on any plastic parts of the filter system. Examples of some solvents to avoid: acetone, methyl acetate (nail polish remover); hexane (spot removers); turpentine, toluene (paint thinners); dry cleaning solutions, insecticides.

Protect from abrasive material

The membranes must be protected from abrasive materials like shavings left in a pipe. Abrasive materials in contact with the membrane can cause irreversible damage to the membrane. All pipes must be flushed clean before installing the filter. All plastic parts of the filter system must be protected from sharp objects like knives, sand paper, or other tools. Cutting or nicking a plastic part can weaken it and cause a leak. Do NOT use abrasive cleansers on any plastic parts.

Protect from water hammer

The system must be protected from shock, pressure surges, or pulsation that may occur inside water pipes. Water hammer occurs in pipes when a valve or faucet shuts quickly. Install a water hammer arrestor (pressure vessel containing compressed air separated from the water by a diaphragm) to reduce pressure shock.

SPECIFICATIONS

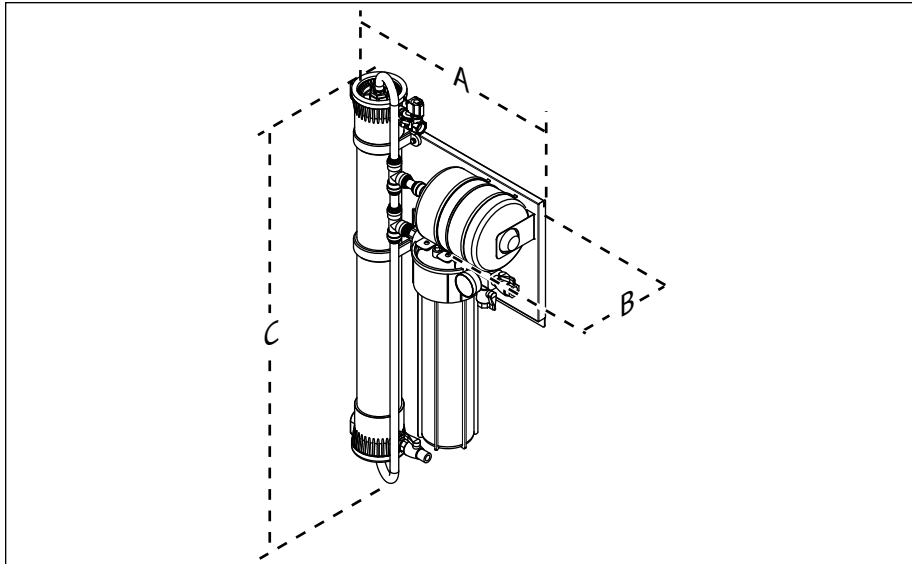

Model & Mfg. No.	Width (A)	Depth (B)	Height (C)
VZN-441VA 9700776	24" (61 cm)	10 1/8" (26 cm)	49 5/16" (125 cm)

Electrical Cord & Plug Configurations

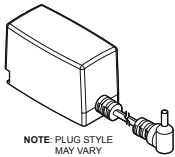
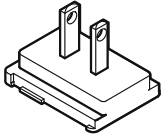
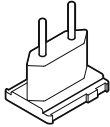
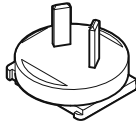
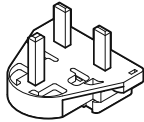
Kit Model Number	Description	Configuration
0012146	DC Power Supply 100 - 240 VAC Includes the 4 plug adaptors below	
	US NEMA 1-15 (2 pin) or NEMA 5-15 (3 Pin)	
	Euro CEE 7/16	
	AS/NZS 3112 AUS (2 Pin)	
	UK BS 1363	

Electrical Ratings

Model & Mfg. No.	Volts	Watts	Amps	Hertz
VZN-441VA 9700776	100-240	10	.08	50/60

Replacement Cartridges

Replacement		Part Number
VZN-441VA	L-440 Ultra Filter	7000412
VZN-441VA	Carbon Element	7000893

PERFORMANCE DATA SHEET

Filter Cartridge Capacities

Maximum Operating Pressure	100 psig (690 kPa)
Maximum Operating Temperature	104°F (40°C)
Minimum Operating Temperature	40°F (4°C)
Maximum Trans Membrane Pressure	45 PSI (3.1 Bar)
pH Range	3-10
MWCO	100 kD
Rated Service Flow: VZN-441VA	13 gpm (49 l/m)

Performance Claims for Percent Reduction

Substance	Influent Challenge Concentration	Reduction Requirement	Minimum % Reduction
cyst1	minimum 50,000/L	99.95%	99.95%
Turbidity	11 ± 1 NTU	≤ 0.5 NTU	99.1%
Particulate Class I Particles 0.5 to < 1µm	at least 10,000 particles /mL	≥ 85%	99.5%
1based on the use of microspheres or Cryptosporium parvum oocysts			



Cartridge Tested and Certified by NSF International against NSF/ANSI Standard 42 and 53 for the reduction of:

Standard No. 42: Aesthetic Effects
Nominal Particulate Reduction
Class I

Standard No. 53: Health Effects
Cyst Reduction & Turbidity Reduction as verified and substantiated by test data.

Cartridge has been tested according to NSF/ANSI Standard 42 and 53 for reduction of the substances listed below. The concentration of the indicated substances in water entering the system was reduced to a concentration less than or equal to the permissible limit for water leaving the system, as specified in NSF/ANSI 42 or 53. While testing was performed under standard laboratory conditions, actual performance may vary.

NOTE: The NSF information provided applies to the Ultra Filter cartridge.

NOTE: Do not use with water that is microbiologically unsafe or of unknown quality without adequate disinfection before or after the system. Systems certified for cyst reduction may be used on disinfected waters that may contain filterable cysts.

INSTALLATION

Unpacking

1. Open the large box. It should contain:
 - a. Plate-mounted VZN system with Ultra Filter Cartridge installed
 - b. Padded envelope containing:
 - Power Adaptor
 - Adaptor Plugs
 - Owner's Manual
 - Mounting Bracket
 - Filter Wrench
 - Glove and Sticker Kit
 - Sanitizing T-Fitting and Plug
 - c. Carbon Element and Carbon Element Housing
2. Remove all packing materials and protective coverings from the system.
3. Remove the information packet. Fill out and mail the warranty card immediately to prevent any delay in obtaining warranty coverage.

NOTE: If any parts are damaged, contact **A.J. Antunes & Co. IMMEDIATELY at 1-800-253-2991 (toll free in the U.S. and Canada) or 1-630-784-1000.**

Equipment Setup

General

When placing the system into service, pay attention to the following guidelines:

- Do NOT immerse cord or plug in water.
- Keep cord away from heated surfaces.

Electrical

The line voltage must match the voltage on the specification label. The plug on the power cord must match the appropriate outlet. Do NOT connect the system to a switched electrical outlet.

Plumbing

NOTE: The system must be connected to the **COLD water line. Do NOT connect the system to the hot water line.**

This system uses the following connections:

Connection	Description
System Inlet	3/4" NPT
System Outlet (Product Water)	3/4" NPT
Drain	3/4" FNPT
Rinse Outlet	3/4" (Garden Hose or 3/4" ID Hose)

When making a plumbing connection to the system, use a back-up wrench on the supporting plumbing. Always use a quality, approved pipe sealant or thread seal tape on pipe threads. Do NOT allow pipe sealant inside pipes.

Do NOT over tighten the connections. Use plastic fittings when connecting to the plastic connections of the system.

If soldered plumbing is used, do NOT apply heat to, or near, the filtration system. Use union (O-ring seal) connections for ease of installation and future servicing.

Suggested Tools and Supplies for Installation

The following tools and supplies are suggested to help with the installation:

- Screwdriver
- Adjustable Wrenches
- Drill with Bits
- Level
- Tape Measure
- Pipe Dope or Thread Seal Tape
- Two Gallon Bucket
- Fresh, Unscented Liquid Chlorine Bleach
- Pipe Wrenches
- Garden Hose (for rinsing)
- Hose or pipe for drain line

CAUTION

Due to its weight and size, the VZN system **MUST** be mounted with the provided Mounting Bracket. Read the Mounting the System section before attempting to mount the VZN system. Use care when lifting heavy objects.

Mounting the System

NOTE: Use caution when lifting and mounting the system. The system **MUST** be mounted using the provided Mounting Bracket.

The VZN system comes with a Mounting Bracket. When mounting the system, pay attention to the following guidelines:

- Allow sufficient access for cartridge replacement. The VZN-441VA should be mounted with 40 inches to the top or bottom.
- Mount the system near but NOT above an appropriate electrical outlet.
- Mount the system near a drain for flushing operations.
- Mount the system before all consumable water filtration processes.
- Mount the system with the provided Mounting Bracket and hardware capable of supporting 120 lbs. or more.
- Secure the Mounting Bracket into wall studs or with the appropriate heavy duty mounting hardware.

The system is pre-assembled to a Back Plate. The Back Plate has mounting holes across the bottom portion to secure the bottom of the system to the wall. Some of the bottom mounting holes may be obscured. Plan your mounting accordingly.

Follow these steps to secure the Mounting Bracket to the wall and seat the VZN system:

1. Use a stud finder and level to attach the Mounting Bracket securely to the wall with the appropriate mounting hardware (Figure 2).
2. The Mounting Bracket is designed so that the VZN system can be lifted and hung on the Mounting Bracket. With assistance, lift the system and seat it onto the Mounting Bracket securely (Figure 2).

3. Secure the bottom portion of the VZN system to the wall using the holes provided. Make sure the mounting hardware secures the system into wall studs or use the appropriate mounting hardware.
4. Screw the Carbon Element Housing onto the Carbon Element Head without the Carbon Element installed.

NOTE: Do NOT install the Carbon Element at this time. The Carbon Element should only be installed after the Ultra Filter Cartridge is rinsed.

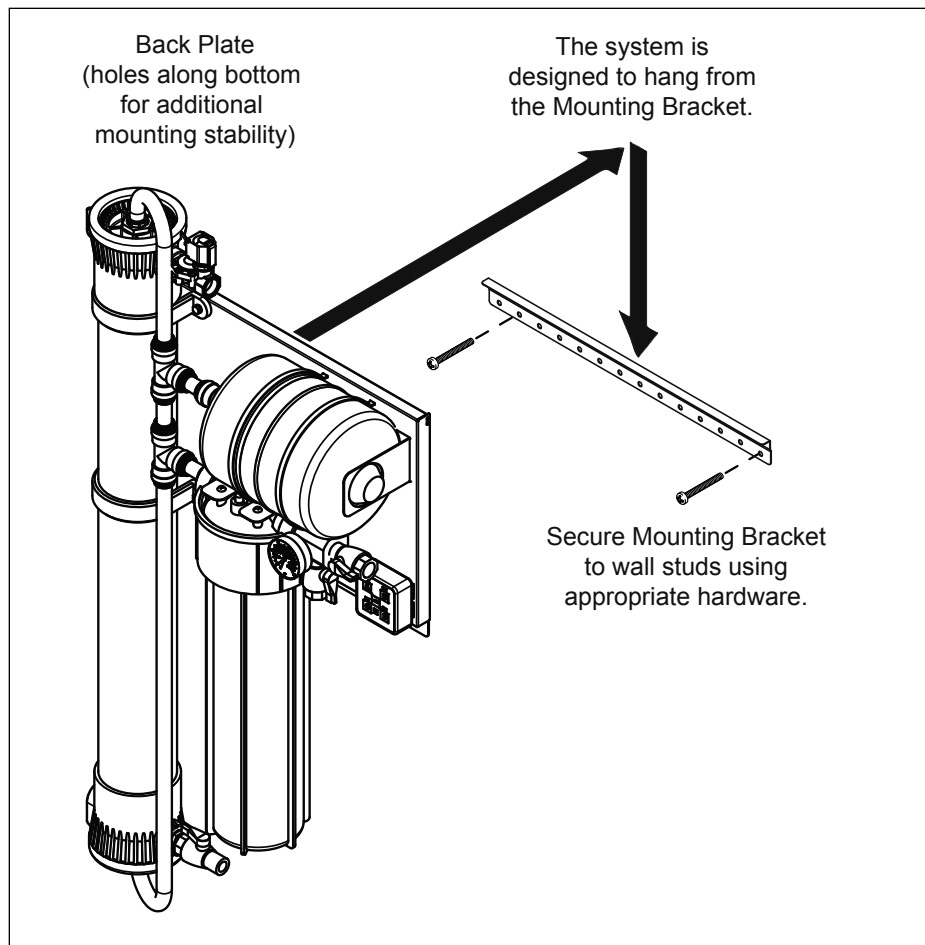

Figure 2. Mounting the System

Drain Valve Connection

The drain is for flushing particle buildup out of the system during self cleaning.

1. Cut a length of tubing (not supplied) so it reaches the drain from the Drain Valve.
2. Connect one end of the hose to the Drain Valve with an appropriate fitting (not supplied) (Figure 3).
3. Direct the other end of the hose to the drain (Figure 3).

When connecting the drain hose, pay attention to the following guidelines:

- The drain line plumbing must be able support the flow rate whenever the system flushes. This flow rate is dependent on the inlet water pressure, inlet pipe size, and system.
- The drain line leading out of the system must be as short as possible and slope downwards without any kinks or loops.
- The drain line plumbing must be positioned and secured at least 2 inches above the drain (Figure 4). This air gap protects the system from contamination in the event of a backed-up drain.
- The drain used must not be blocked or restricted.
- The drain used must be as large or larger than the drain line plumbing.

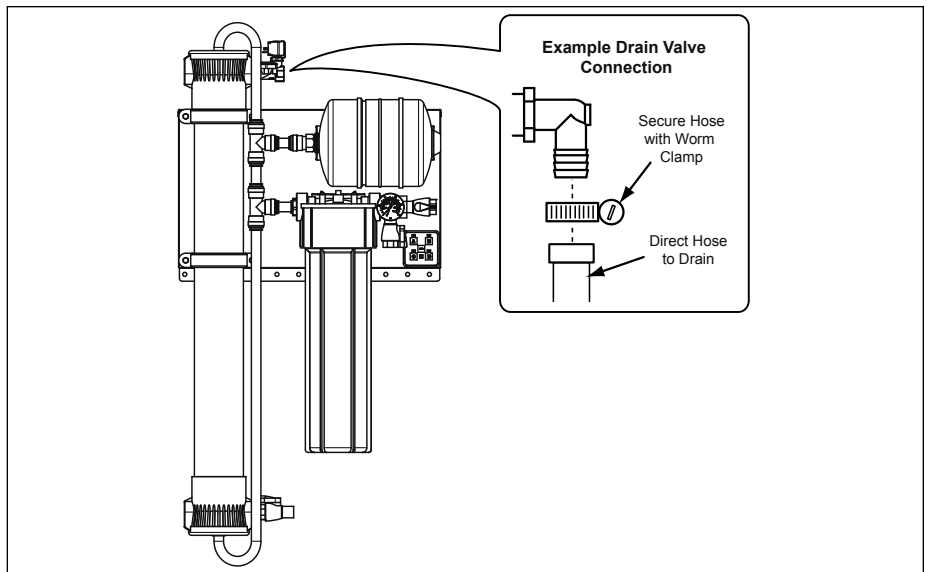

Figure 3. Drain Valve Connection

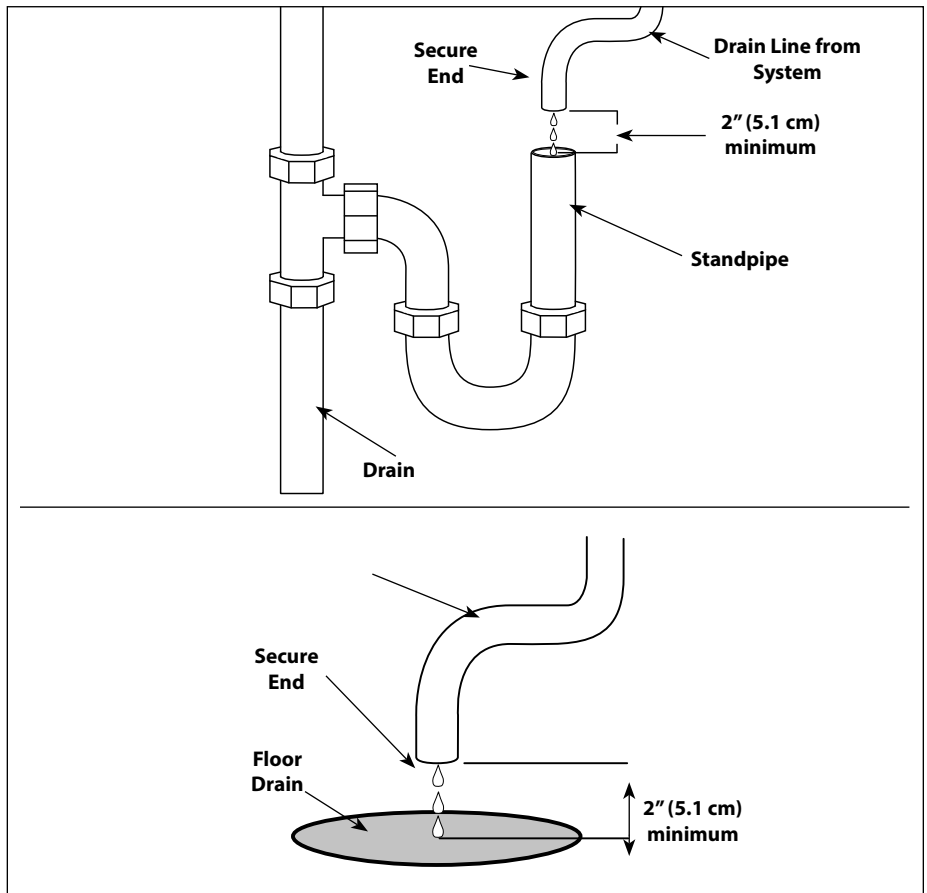

Figure 4. Drain Line Plumbing

Rinse Valve Connection

1. Obtain a length of 3/4" garden hose long enough to reach from the Rinse Valve to the drain.
2. Install a gasket in the end of the hose (non-drain end).
3. Connect the hose to the Rinse Valve fitting. Use a back-up wrench on the fitting if required (Figure 5).
4. Direct the other end of the hose to the drain. Secure as necessary.

NOTE: The drain **MUST** accommodate a flow of up to 15 gpm.

CAUTION

Do NOT use the Rinse Valve for consumable water.

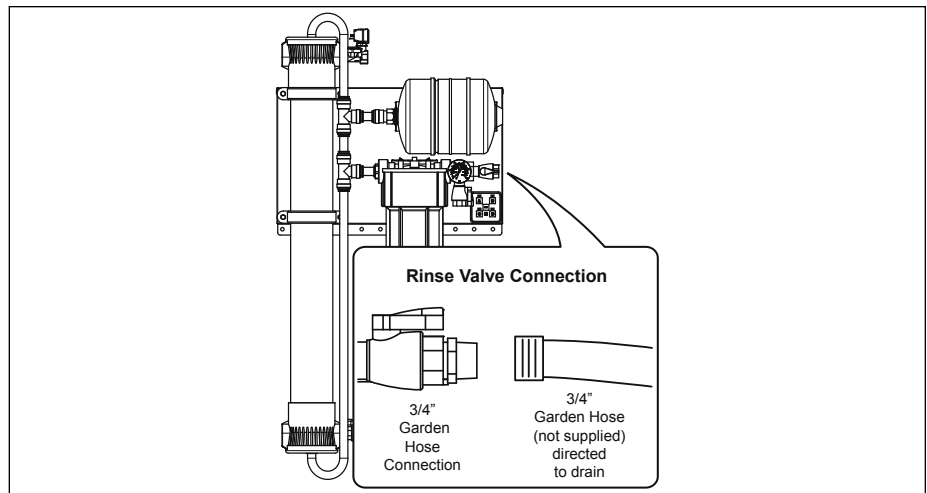

Figure 5. Rinse Valve Connection

System Inlet Connection

The System Inlet has a 3/4" NPT male thread at the Inlet Valve (Figure 6). Do NOT overtighten fittings as this could cause the plastic ball valve to crack.

Use plastic fittings and a pipe thread sealant approved for use on PVC fittings when making connections.

Filtered Water Permeate Outlet Connection

The System Outlet has a 3/4" NPT female thread at the Outlet Valve (Figure 6). Do NOT overtighten fittings as this could cause the plastic ball valve to crack.

Use plastic fittings and a pipe thread sealant approved for use on PVC fittings when making connections.

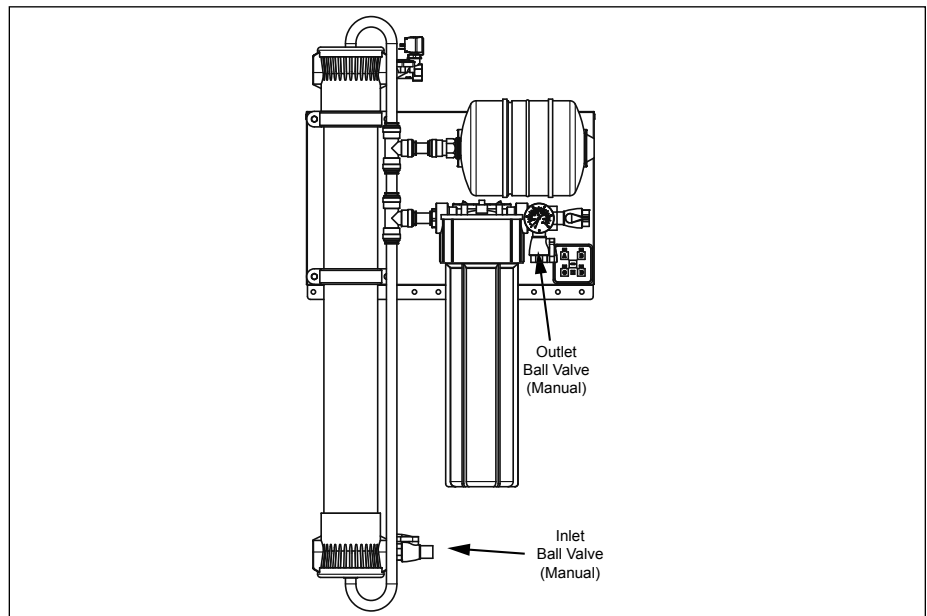

Figure 6. Inlet and Outlet Connections

Inlet Water Plumbing

The "T" Fitting with plug (supplied) should be installed at the System Inlet. This fitting will be used for sanitizing the system and downstream plumbing (Figure 6a).

Before connecting the fitting to the System Inlet, the plumbing to the system must be flushed clear of all debris. Hold a bucket at the inlet water line and slowly open the Inlet Water Valve. Allow the pipe to flush until all debris is removed.

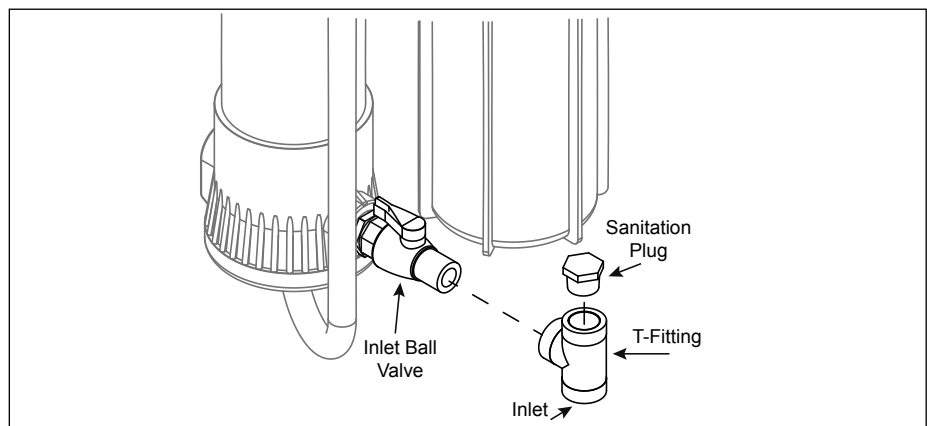

Figure 6a. Installing a T-Fitting for Sanitizing

Installing a Bypass

It is recommended that an optional bypass be installed to help with replacing cartridges and servicing the system. Installation of a bypass can be done easily as the Inlet and Outlet Ball Valves are already installed.

1. Install tees on the end of the plumbing leading to the Inlet and Outlet Ball Valves.
2. Connect the two tees by installing plumbing and a fully ported (preferably 3/4") Ball Valve.
3. During system use, open the Inlet and Outlet Ball Valves and close the Bypass Ball Valve.
4. When performing service, close the Inlet and Outlet Ball Valves and open the Bypass Ball Valve.

Starting the Controller

1. Select the proper AC plug for your electrical outlet and install it onto the power supply.
2. Plug the appropriate end of the power cord into the controller.
3. Plug the other end of the power cord into the electrical outlet. The LEDs on the controller turn on.
4. The controller automatically enters Flush Mode and the Flush LED starts to flash.
5. When flushing completes, the Flush LED stops flashing and one or more LEDs remains lit, indicating the unit has power and which interval is selected in the controller.

Rinsing the Ultra Filter Cartridge

The Ultra Filter Cartridge comes pre-installed in the VZN system.

NOTE: Ultra Filter Cartridge must be rinsed to drain before use. Rinsing to drain removes storage solution and air. Do NOT rinse into carbon if present. Carbon life and/or performance may be affected.

NOTE: Make sure the Carbon Element, if present, is NOT installed. These should only be installed after the Ultra Filter Cartridge has been rinsed.

1. Direct water from the Rinse Ball Valve to a drain.
 2. Close the Outlet Ball Valve.
 3. Close the Inlet Ball Valve.
 4. Open the Rinse Ball Valve.
 5. Slowly turn on the water supply to the VZN system.
 6. Slowly open the Inlet Ball Valve. Air and water will come out of the Rinse Ball Valve.
 7. Press the **FLUSH** button. The Drain Valve opens and air and water flows out of the drain line. Repeat six times to ensure all air and storage solution are flushed out of the Ultra Filter Cartridge.
 8. Continue to allow water to run at full flow out of the Rinse Ball Valve for at least 15 minutes.
9. After 15 minutes, close the Rinse Ball Valve and allow the system to sit for 15 minutes without any water flow to release any trapped air from the Ultra Filter Cartridge.
 10. Inspect the unit for any leaks, repairing as needed.
 11. After 15 minutes, open the Rinse Ball Valve and wait for 15 more minutes to flush out any remaining air.
 12. Close the Rinse Ball Valve and disconnect the garden hose.
 13. Press the **FLUSH** button to open the Drain Valve. Repeat six times to ensure any remaining air is flushed out of the system.
 14. Open the closest downstream tap or faucet.
 15. Slowly open the Outlet Ball Valve and allow water to run through the system and out the faucet for five minutes.

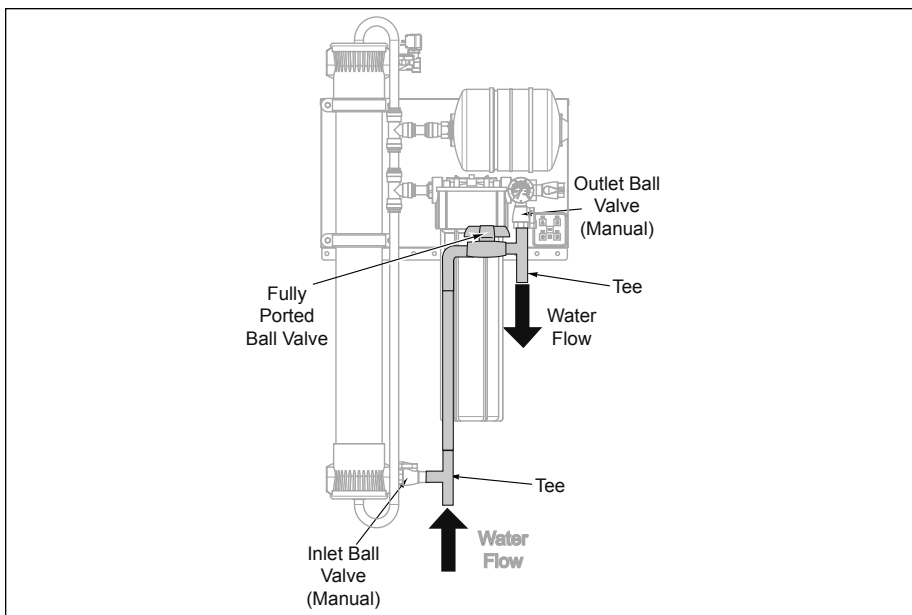

Figure 7. Install Bypass

Sanitizing the System and Lines

The plumbing must be sanitized to eliminate possible contamination that may have occurred during the installation process.

One ounce (30 ml) of liquid chlorine bleach (regular bleach, unscented 5.25 % - 6 % sodium hypochlorite) or Kay-5 sanitizer solution (Sodium Dichloro-s-Triazinetrione Dihydrate, 6%) or equivalent can be used to sanitize the plumbing.

The Kay-5 sanitizer solution is made by dissolving a 1 oz. packet of Kay-5 powder in 2 oz. (60 ml) of clean warm water. This can be done by removing 1 inch from the top of the Kay-5 packet and adding the 2 oz. of warm water to the packet. Mix with a coffee stirrer to dissolve. When added to the system, this will create a 60-100 ppm chlorine solution.

NOTE: Follow the handling and safety instructions supplied with the sanitizer.

NOTE: If installed, remove the Carbon Element from the system *BEFORE* Sanitizing.

1. Follow the steps in the *Rinsing the Ultra Filter Cartridge* in the Installation section of this manual.
2. Turn off the water to the system.
3. Open the faucet or tap closest downstream to the system.
4. Allow the system and plumbing to drain.
5. Remove the plug installed in the sanitizing "T" fitting at the inlet of the system. Allow the water to drain out of the system.
6. Pour the sanitizer into the inlet sanitation fitting using a cup or funnel. Be careful not to spill the sanitizer onto clothing or skin.
7. Reattach the plug on the sanitation fitting.
8. Slowly turn on the water supply to the system.
9. Allow water to flow through the system and out of the open faucet or tap until the smell of sanitizer is present.
10. Close the faucet or tap.
11. Let the system stand without water flow for at least 15 minutes to allow the sanitizer to sanitize the pipes.
12. After 15 minutes without water flow, open the faucet or tap.
13. Allow water to flow through the system until the presence of sanitizer is gone.
14. Open all other faucets and taps in line with the system to flush any remaining sanitizer from the plumbing.
15. Close all faucets and taps.

Rinsing the Carbon Element

The Carbon Element **MUST** be rinsed before using the system the first time and immediately after replacing the Carbon Element.

1. Install the Carbon Element into the Carbon Element Housing.
 2. Screw the Carbon Element Housing (containing the Carbon Element) into place on the Carbon Element Head. The Housing will come to a hard stop at the end of the thread. Use a Filter Wrench if necessary.
 3. Direct water from the Rinse Ball Valve to a drain. Then open the Rinse Ball Valve and close the Outlet Ball Valve.
 4. Turn on the water to the system by slowly opening the Inlet Ball Valve.
 5. Allow water to flow through the Carbon Element Housing to flush out trapped air and any debris that may be present.
 6. To help remove trapped air from the Housing, press the RED Pressure Relief Button on the top of the housing until water just begins to come out.
 7. Flush the Carbon Element for at least 5 minutes.
- NOTE:** Do NOT consume water used during this process.
8. Close the Rinse Ball Valve when rinsing completes.
 9. Open the Outlet Ball Valve. The system is now ready for use.
 10. For new piping installations: After making the connection to the System Outlet:
 - a. Open the faucet or tap closest to the filter system
 - b. Slowly open the Inlet Valve.
 - c. Allow the pipe to flush until all debris is removed.

OPERATION

Overview

The VZN system operates in two modes:

- Normal Operation Mode
- Flush Mode

During Normal Operation Mode, water enters the Inlet and flows through the Ultra Filter before exiting the Permeate Outlet as usable product water.

During Flush Mode, the Drain Valve opens and water entering the Inlet flushes and cleans the Ultra Filter membrane by removing any debris collecting on the membrane wall.

The Drain Valve is only powered during Flush Mode.

NOTE: Do NOT unplug the power cord or turn off the system during Flush Mode. If there is a power outage or the system is unplugged, water will continue to be filtered but the system will NOT flush. This could cause the Ultra Filter to plug prematurely and may reduce the life of the filter.

The flush is automated by the Universal Pulse Controller to last 10 seconds and take place in one-hour intervals. This interval can be changed (see **Changing the Interval Setting** in the Maintenance section of this manual).

CAUTION

Changing the flush interval may cause the Ultra Filter to plug prematurely and may reduce the life of the filter. Consult the factory for more information.

Manual Flushing

A manual flush can be activated at any time by pressing the FLUSH button on the Universal Pulse Controller.

When the FLUSH button is pressed, the Flush LED on the controller flashes and the Drain Valve opens for 10 seconds. After flushing is complete, the Drain Valve will close, the Flush LED will stop flashing and the unit will automatically return to Normal Operation Mode.

NOTE: A manual flush will not affect the interval flush setting.

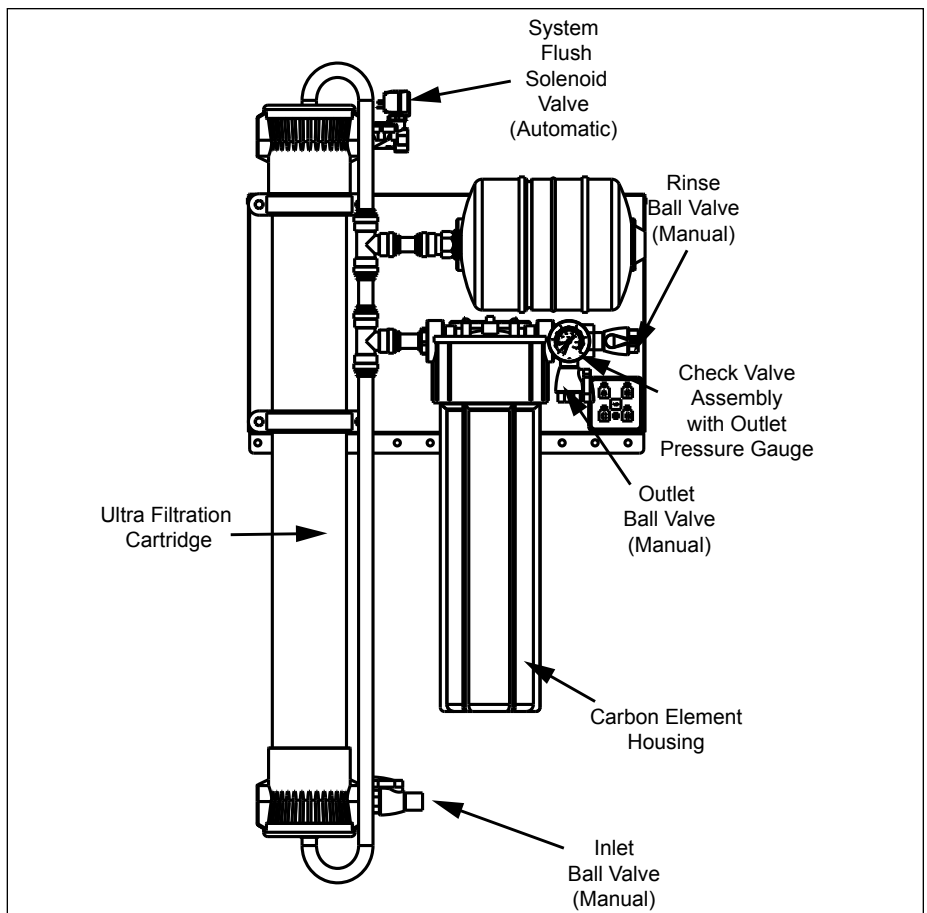

Figure 1. System Components

MAINTENANCE

Replacing the Ultra Filter Cartridge

NOTE: Always install new Carbon Element after replacing the Ultra Filter Cartridge.

1. Turn off water to the system by closing the Inlet Ball Valve and Outlet Ball Valve.
2. Press the FLUSH button to flush the system and relieve pressure. Repeat several times to ensure permeate tank is empty.
3. Remove the Carbon Element if present.
4. Locate the long hooked tubing on the right and disconnect the long end from the tee by pushing the collet squarely against the face of the fitting.
5. With the collet pushed in place, pull the tubing from the fitting with your right hand.

NOTE: Water may drain from the tubing as it is removed. Make sure there is enough room next to the system to remove the cartridge.

6. Remove the Snap Ring (Figure 8) from the Ultra Filter Housing. Grab the raised lug with a pair of pliers and pull towards the center of the End Cap and away. The Snap Ring should lift out of its groove.
7. Remove the End Cap, End Cap O-Ring, and Cartridge (Figure 8) from the housing.

NOTE: If the Cartridge does not easily come out of the Housing, remove the opposite End Cap for assistance during Step 5.

8. Inspect the Large End Cap O-rings and End Cap O-ring for nicks or cuts. Replace as needed.
9. Lubricate all O-rings with a food-grade silicone lubricant. Apply a light coating of lubricant to the inside center tube at both ends of the new cartridge.
10. Record the serial number of the new cartridge. The cartridge serial number is engraved on one end of the outer tube (for example: 05K 12013).

11. Install the End Cap O-ring on the End Cap and insert the Large End Cap into the end of the new cartridge.
12. Position the new cartridge and End Cap at the housing and gently insert into the housing.
13. Press the End Cap into position until it is fully seated and the Snap Ring groove is visible.
14. Install the Snap Ring by guiding the non-lugged end into the groove first, pushing outward and working around the ring until it snaps into place.

NOTE: Make sure that the Snap Ring is fully seated before turning the water on.

15. Reattach the tubing that was removed in Steps 3 and 4. Be sure the tubing is pushed past the O-ring.

NOTE: Make sure the fitting is completely inserted onto the tubing past the O-ring. A loose connection results in leaking at the point of connection.

16. Rinse the new Ultra Filter Cartridge before placing the system back into operation. Follow the *Rinsing the Ultra Filter Cartridge, Sanitizing the System and Lines, and Rinsing the Carbon Element* procedures in the Installation section of this manual to complete the cartridge change.
17. When rinsing is complete, repressurize the system by opening the Outlet Ball Valve then opening the Inlet Ball Valve.

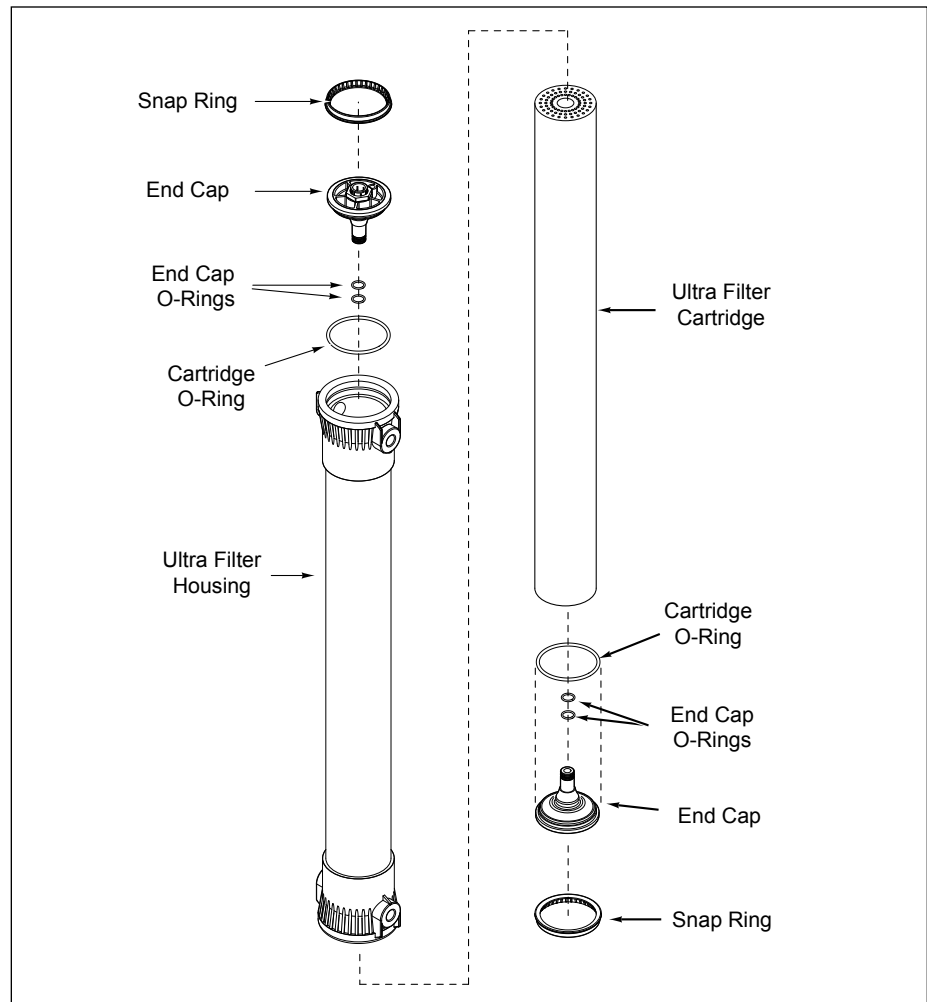

Figure 8. Replacing the Ultra Filter Cartridge

Rinsing and Replacing the Carbon Element

1. Turn off the water to the system by closing the Inlet Ball Valve and Outlet Ball Valve.
2. Open the Rinse Ball Valve and allow the system to drain to ensure the permeate tank is empty.
3. Press and hold the RED Pressure Relief Button on the top of each of the Carbon Element Housing to lower the water level inside the housings by 2 to 3 inches.
4. Remove the Carbon Element Housing (Figure 9).
5. Empty any water into a drain and discard the old Carbon Element.
6. Inspect the O-ring on the Carbon Element Housing (Figure 9). Replace the O-ring if it is cracked, twisted, or missing.
7. Lubricate the O-ring with an approved food grade lubricant and install into the Carbon Element Housing.
8. Install the new Carbon Elements into the Carbon Element Housing.

NOTE: Make sure the Gasket remains in place in the recessed grooves on both ends of the Carbon Element.

9. Screw the Carbon Element Housing (containing the Carbon Element) into place on the Carbon Element Head. The Housing will come to a hard stop at the end of the thread. Use a Filter Wrench if necessary.

NOTE: Do NOT overtighten the Carbon Element Housing.

10. Direct water from the Rinse Ball Valve to a drain.

NOTE: Direct the Rinse Ball Valve to a drain. Do NOT use the water resulting from the flush procedure.

11. Open the Rinse Ball Valve. Turn on the water to the system by slowly opening the Inlet Ball Valve. Allow water to flow through the Carbon Element and Housing. This clears out trapped air and any carbon fines.
12. To help remove trapped air from the Carbon Element Housing, press the RED Pressure Relief button on the top of the Housing until water just begins to come out.
13. Rinse the Carbon Element for at least 5 minutes.

NOTE: Do NOT consume the water used for rinsing the Carbon Element.

14. When the rinsing is complete, close the Rinse Ball Valve and open the Outlet Ball Valve.
15. The system is now ready for use.

System Sanitization

The system and downstream plumbing should be sanitized every six months. When necessary, follow the procedure in Sanitizing the System and Lines in the Installation section of this manual.

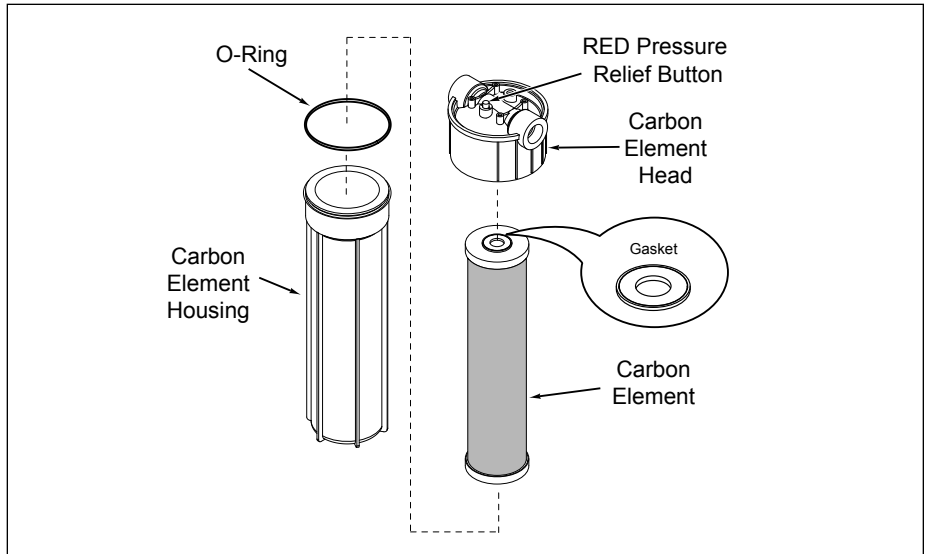

Figure 9. Carbon Element

Changing the Interval Setting

CAUTION

Changing the flush interval may cause the Ultra Filter to plug prematurely and may reduce the life of the filter. Consult the factory for more information.

Though not recommended, the interval setting on the Universal Pulse Controller can be changed. If the setting must be changed, use the chart below. Press and hold the corresponding button. After 5 seconds, the Button LED will turn on. After 10 seconds, the Flush LED will also turn on.

Flush Interval	Button	Hold Time	Button LED	Flush LED
15 minutes	A	10 seconds	On	On
30 minutes	B	10 seconds	On	On
45 minutes	C	10 seconds	On	On
1 hour	A	5 seconds	On	Off
4 hour	B	5 seconds	On	Off
6 hours	C	5 seconds	On	Off
12 hours	D	5 seconds	On	Off
24 hours	D	10 seconds	On	On

Table 1. Flush Interval Settings

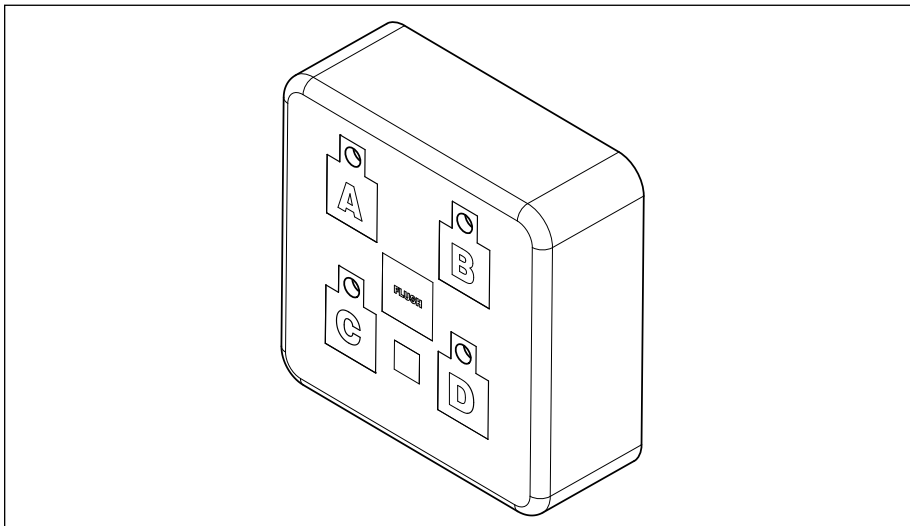

Figure 12. Universal Pulse Controller

CAUTION

Air pre-charge should only be checked and adjusted under zero system pressure. The system must be depressurized before checking the tank pre-charge. Do NOT adjust the tank air pre-charge with the system under pressure.

CAUTION

Be careful when adding air to the tank. Do NOT add too much air pressure to the tank.

Resetting the Timer Program

During the normal operation, the system will flush according to the set interval. It is possible the system will flush at a time of high water use. If this poses a problem, the controller can be reset. Unplug the power supply, wait for 5 seconds, and then plug the power supply in. When power is restored to the controller, it will automatically enter Flush Mode. The controller will then begin timing from the point when power is restored based on the interval setting selected.

Check Permeate Tank Air Pre-Charge

It is recommended the permeate tank air charge be checked every six months.

Tools and supplies required:

- Air Pressure Gauge, 5-40 psi range (0.3-2.7 bar) with tire valve (Schrader Valve) connection
- Source of compressed air (manual bicycle tire pump or air compressor)

1. Depressurize the system by closing the Inlet and Outlet Valves and opening the Rinse Valve. Make sure the Permeate Tank is fully drained.
2. Unscrew the protective cap from the air valve on the tank.
3. Use the pressure gauge to check the tank pre-charge for pressure.

NOTE: If any water comes out the air valve, the tank bladder has ruptured and the tank needs to be replaced.

4. The permeate tank should have a pressure of 28-31 psi.
 - To add pressure to the permeate tank, use a manual bicycle tire pump or other source of compressed air.
 - To release pressure from the permeate tank, press the center pin on the air inlet valve.
5. Once the permeate tank is at 28-31 psi, replace the protective cap on the air valve.
6. Pressurize system by closing the Rinse Valve and opening the Inlet and Outlet Valves.

TROUBLESHOOTING

Problem	Possible Cause	Corrective Action
Unit does not have power.	The power cord is not plugged into the appropriate outlet or control box.	Plug power cord into the appropriate outlet.
	The unit is plugged into a switched electrical outlet.	Plug the power cord into an unswitched outlet.
	Universal Pulse Controller is inoperable. Transformer is defective.	Contact your maintenance person or Authorized Service Agency.
No water comes out of the filter system.	Inlet/Outlet Ball Valves closed.	Open the Inlet/Outlet Ball Valves.
	System depressurized.	Pressurize system.
	Drain Valve is stuck open.	Clean, rebuild, and/or replace the Drain Valve.
	Rinse Ball Valve is open.	Close the Rinse Ball Valve.
	The system may be in a flush cycle.	Wait for the flush cycle to end.
	Inlet Strainer (if installed) is plugged.	Clean or replace Inlet Strainer
	Ultra Filter Cartridge is plugged. Carbon Element is plugged.	Check Permeate Tank air pre-charge. Replace Ultra Filter Cartridge. Replace Carbon Element.
Low water flow comes out of the filter system.	See above.	See above.
	The inlet water pressure is too low.	Boost the inlet water pressure.
	The outlet check valve may be plugged or defective.	Clean or replace the outlet check valve assembly.
	The inlet flow restrictor may be plugged.	Clean or replace the inlet flow restrictor.
Water tastes bad.	Carbon Element need replacing.	Replace Carbon Element.
	Storage/shipping solution not completely rinsed out of the system.	Rinse the system for a longer period of time; replace Carbon Element.
	Biological growth in pipes.	Sanitize plumbing.
	Water condition changed. Broken capillaries in Ultra Filter Cartridge.	Consider installing additional filtration. Replace Ultra Filter Cartridge.
Flush runs continuously.	Drain Valve stuck open.	Clean, rebuild, or replace the Drain Valve.
	Controller sending continuous signals to valve.	Replace the controller.
Water splashes at drain during flush.	Drain line not positioned properly.	Reposition the end of the drain line.
	Drain not capable of handling high flow rate.	Clean drain; find alternate drain.
Water leaks at ends of the Ultra Filter cartridge after changing cartridge.	O-ring not lubricated.	Lubricate O-ring with food grade lubricant.
	O-ring is split, cut, or twisted.	Replace O-ring.
Water leaks from Carbon Element.	O-ring not lubricated.	Lubricate O-ring with food grade lubricant.
	O-ring is split, cut, or twisted.	Replace O-ring.
Water leaks from system fitting or connection.	Fitting broken or loose.	Tighten or replace the fitting.
	Not enough pipe thread sealant used.	Redo the fitting with the proper amount of sealant.

REPLACEMENT PARTS

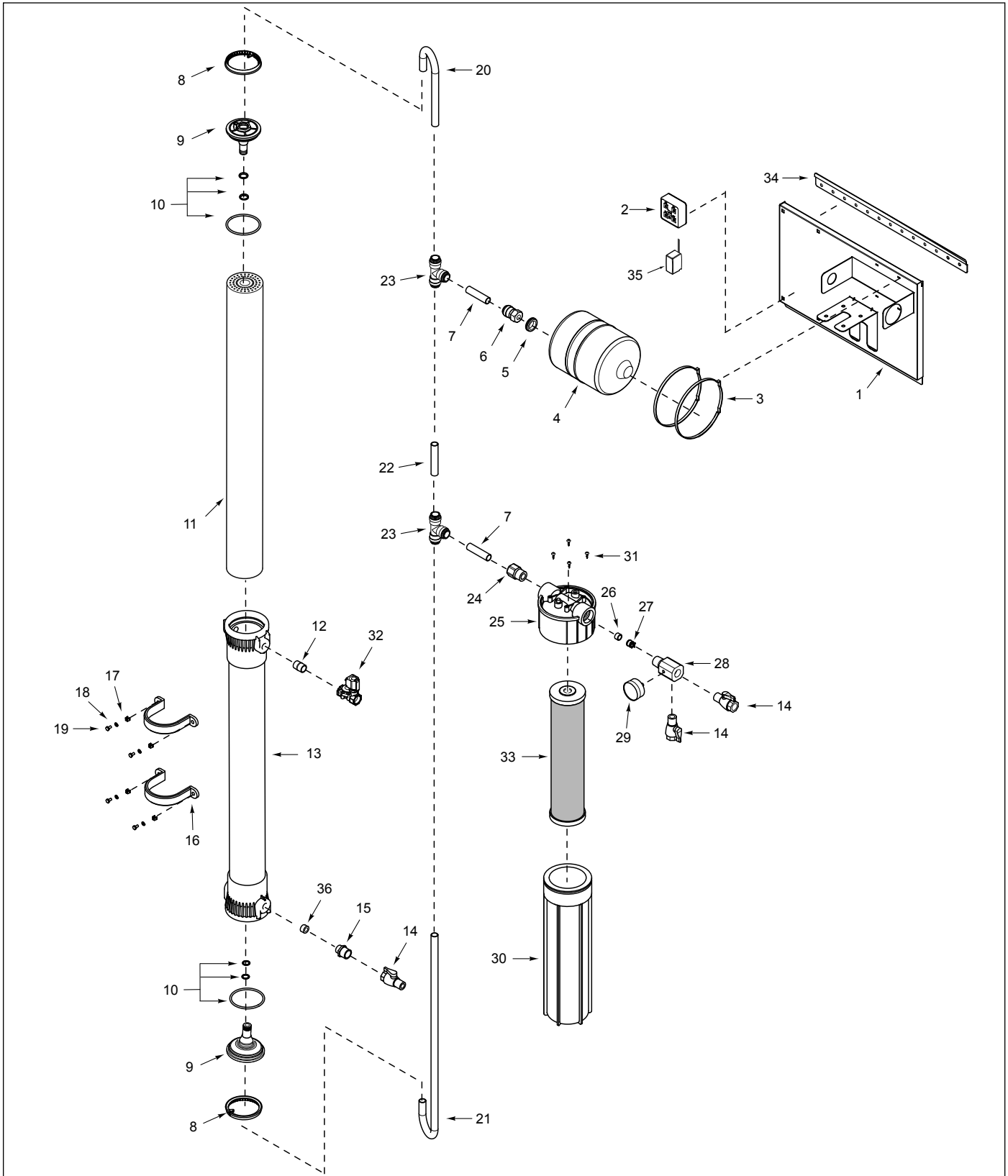

**Replacement Parts can be purchased from an authorized dealer. Contact
A.J. Antunes & Co. at 1-630-754-1000 or toll free in the United States at 1-800-253-2991.**

Item	Part #	Description	Qty.
1	0505886	VZN Back Plate	1
2	0012357	Universal Pulse Controller	1
3	4060438	36" Black Cable Tie	2
4	7000921	Permeate Tank Replacement Kit	1
5	0400381	Grommet, 1.75" OD x 1.197" ID	1
6	2190158	Female Connector, 3/4" CTS x 3/4" NPT	1
7	2010205	Tubing	2
8	2180181	Lock Ring	2
9	2180230	End Cap 4" Quick Disconnect	2
10	7000413	O-ring Replacement Kit	1
11	7000412	Ultra Filter Cartridge Replacement Kit (Incl. #10)	1
12	2070117	Nipple, Close 3/4" NPT	1
13	2180202	Ultra Filter Housing 440	1

Item	Part #	Description	Qty.
14	2170131	Ball Valve, 3/4" Female to 3/4" Male	3
15	2190171	Nipple Reducer Hex, 1" to 3/4"	1
16	2180287	UFL Housing Clamp	2
17	3000116	Nut Retainer, 1/4"-20	4
18	325P154	Washer, Lock 1/4" (Pkg. of 10)	1
19	325P109	Screw, 1/4"-20 x 1/2" (Pkg. of 10)	1
20	2010204	Tubing, Bent 180° Top	1
21	2010207	Tubing, Bent 180° Bottom	1
22	2010206	Tubing	1
23	2190155	Union Tee	2
24	2190189	Adaptor, Tube to 1" NPT	2
25	2180220	Carbon Element/TAC-05 Head	2
26	2180290	Check Valve Bushing	1

Item	Part #	Description	Qty.
27	2170127	Check Valve Insert	1
28	2180298	Outlet Adaptor, Machined	1
29	2170128	PSI Pressure Gauge	1
30	2180283	Carbon Element Housing	1
31	308P213	Screw, 1/4"-15 x 3/4" (Pkg. of 10)	1
32	4040189	Solenoid Valve, NC 3/4" NPT	1
33	7000893	Antimicrobial Carbon Element Replacement Kit	1
34	0505871	VZN Mounting Bracket	1
35	0012146	Power Adapter	1
36	0021666	Flow Regulator Assy., 15 gpm	1
37	0700769	Wiring Harness (not shown)	1
38	2190184	Tee, PVC, 3/4" NPT (not shown)	1
39	2190135	Plug, Nylon, 3/4" NPT (not shown)	1

LIMITED WARRANTY

Equipment manufactured by A.J. Antunes & Co. has been constructed of the finest materials available and manufactured to high quality standards. These units are warranted to be free from defects in materials and workmanship for a period of two years from date of purchase under normal use and service, and when installed in accordance with manufacturer's recommendations*. The ultra filtration membrane cartridge is warranted under the same terms and conditions on a prorated basis for 36 months from date of purchase.

*To ensure continued proper operation of the units, follow the maintenance procedure outlined in the Owner's Manual.

1. This warranty does not cover failures due to improper system installation, defects caused by improper storage or handling prior to placing of the equipment into service. This warranty does not include overtime charges or work done by unauthorized service agencies or personnel. This warranty does not cover normal maintenance, calibration, or regular adjustments as specified in operating and maintenance instructions of this manual, and/or labor involved in moving adjacent objects to gain access to the Equipment.
2. A.J. Antunes & Co. reserves the right to make changes in design or add any improvements on any product. The right is always reserved to modify equipment because of factors beyond our control and government regulations. Changes to update equipment do not constitute a warranty charge.
3. **If shipment is damaged in transit, the purchaser should make a claim directly upon the carrier. Careful inspection should be made of the shipment as soon as it arrives and visible damage should be noted upon the carrier's documentation. Damage should be reported to the carrier. This damage is not covered under this warranty.**
4. THIS WARRANTY IS EXCLUSIVE AND IS IN LIEU OF ALL OTHER WARRANTIES, EXPRESSED OR IMPLIED, INCLUDING ANY IMPLIED WARRANTY OR MERCHANTABILITY OR FITNESS FOR A PARTICULAR PURPOSE, EACH OF WHICH IS HEREBY EXPRESSLY DISCLAIMED. THE REMEDIES DESCRIBED ABOVE ARE EXCLUSIVE AND IN NO EVENT SHALL A.J. ANTUNES & CO. BE LIABLE FOR SPECIAL CONSEQUENTIAL OR INCIDENTAL DAMAGES FOR THE BREACH OR DELAY IN PERFORMANCE OF THIS WARRANTY.

Prices and specifications are subject to change without notice.



U.S. Headquarters

Carol Stream, Illinois
Phone: (630) 784-1000
Toll Free: (800) 253-2991
Fax: (630) 784-1650

China Facility

Suzhou, China
Phone: 86-512-6841-3637
Toll Free: 86-512-6841-3907
Fax: 400-0-7878-22