



Atlas Metal

INDUSTRIES, INC.

A subsidiary of Mercury Aircraft, Inc

1135 N.W. 159th DRIVE, MIAMI, FLORIDA 33169

TEL.: (305) 625-2451 TOLL FREE (800) 762-7565 FAX: (305) 623-0475

WCM/WCMD/WCMDL/WCML/WCMDL/WCMDCL & WCMHP SERIES

Service and Installation Manual

Please read this manual completely before attempting to install or operate this equipment!
Notify carrier of damage! Inspect all components immediately. See page 2.



DROP-IN COLD PAN
REFRIGERATED STANDARD DEPTH,
FULL DEPTH, SIDE COILS & SLIM-LINE
SELF CONTAINED OR REMOTE



DROP-IN HOT/COLD PAN
DUAL SERVICE HOT OR COLD
(HOT MODE-WATER MUST BE USED)



Effective Date: 2017
IMPORTANT INFORMATION
READ BEFORE USE

CONTENTS

RECEIVING & INSPECTING EQUIPMENT.....	1
SERIAL AND MODEL # LOCATION.....	1
WCM SPECIFICATIONS, FEATURES ACCESSORIES.....	2
ELECTRICAL CHARACTERISTICS AND CUT-OUT REQUIREMENTS.....	3
INSTALLATION, OPERATION AND S/S MAINTENANCE.....	4
PARTS LIST.....	5
WCM-HP SPECIFICATIONS FEATURES AND ACCESSORIES.....	6
ELECTRICAL CHARACTERISTICS AND CUT-OUT REQUIREMENTS.....	7
INSTALLATION, OPERATION AND S/S MAINTENANCE.....	8
PARTS LIST.....	9
AUTOMATIC WATER FILL INSTALLATION, OPERATION & PARTS LIST.....	10
TROUBLE SHOOTING GUIDE.....	11
ELECTRICAL & REFRIGERATION CHART.....	12
ELECTRICAL SCHEMATICS.....	13,14,15
LIMITED WARRANTY.....	16
WARRANTY INFORMATION.....	17

RECEIVING AND INSPECTING THE EQUIPMENT

1. VISUALLY INSPECT THE SHIPPING CRATE. DAMAGE SHOULD BE NOTED AND REPORTED TO THE DELIVERING CARRIER.
2. IF DAMAGED, OPEN AND INSPECT CONTENTS WITH CARRIER.
3. IF CRATE IS NOT DAMAGED AND THERE IS CONCEALED DAMAGE TO THE EQUIPMENT, NOTIFY THE CARRIER. NOTIFICATION MUST BE MADE VERBALLY AND IN WRITING.
4. REQUEST AN INSPECTION BY THE SHIPPING COMPANY FOR THE DAMAGED EQUIPMENT WITHIN 10 DAYS FROM RECEIPT OF THE EQUIPMENT
5. FREIGHT CARRIERS CAN SUPPLY THE NECESSARY FORMS ON REQUEST.
6. SAVE ALL CRATING MATERIALS UNTIL INSPECTION HAS BEEN MADE OR WAIVED.

RECEIVING AND INSPECTING THE EQUIPMENT

THE SERIAL AND MODEL# CAN BE FOUND ON THE CONDENSING UNIT ENCLOSURE - SEE OPERATORS SIDE CONTROL PANEL WHEN CALLING ATLAS FOR PARTS AND SERVICE. ALWAYS HAVE THIS INFORMATION AVAILABLE.

SERIAL #: _____

MODEL #: _____

INSTALLATION DATE: _____



Atlas Metal
INDUSTRIES, INC.

A subsidiary of Mercury Aircraft, Inc

1135 N.W. 159th DRIVE, MIAMI, FLORIDA 33169

TEL.: (305) 625-2451 TOLL FREE (800) 762-7565 FAX: (305) 623-0475

Web Page: www.atlasfoodserv.com E-Mail: sales@atlasfoodserv.com

Project: _____

Item No.: _____

Quantity: _____

DROP-IN SERVING EQUIPMENT



WCM-2

COLD PAN

Refrigerated

4-5/8" Standard Depth

Self-Contained

- WCM-1**
- WCM-2**
- WCM-3**
- WCM-4**
- WCM-5**
- WCM-6**

SPECIFICATIONS

TOP: Constructed of 18 gauge, type 304 stainless steel, die stamped with a raised perimeter bead. There shall be a solid vinyl gasket under the beaded edge to form a seal to the counter top, thus preventing seepage or marring of the counter top. Embossed mounting lugs are provided along the inner surface of the top to hold the removable separator channels in place.

LINER: The inner liner shall be 18 gauge, type 304 stainless steel, one piece construction, all welded, ground and polished to a uniform finish. All corners are covered with a minimum 1/4" radius. The liner has copper tubing firmly soldered to the exterior bottom. A 3/4" dia. drain with strainer, 4" PVC nipple, and valve is provided.

INSULATION: The pan is fully insulated with high density polystyrene, 1" thick on all sides, 1-1/2" thick on the bottom and enclosed with a 22 gauge galvanized steel outer case.

REFRIGERATION SYSTEM: The compressor housing shall be fabricated from 14 gauge galvanized and bolted to the base of the unit. A fully self-contained condensing unit is provided with a hermetically sealed compressor and a thermostat control. The system is fully charged with CFC free refrigerant and ready to operate.

NOTE: Proper ventilation must be provided in counter.

ELECTRICAL: The unit will be wired for 15 amps., 120 volt, single phase, with an on/off thermostat switch and pilot light. A 6' long, 3-wire cord and plug (NEMA 5-15P) will be provided.

Specifications subject to change without notice.

STANDARD FEATURES

- Fully insulated for maximum efficiency and energy savings
- Factory applied gasket - makes installation a snap and seals units to the counter top, thus eliminating seepage
- Accommodates standard 12" X 20" pans with the use of separator channel(s), or fractional size pans with the use of optional adapter bars
- 1-Year Parts & Labor Warranty
- NSF Certified; UL Recognized

ACCESSORIES

- **5YW** - 5-Year Compressor Warranty
- **WFB** - Stainless steel perforated false bottom
- Stainless Steel adapter bars (pg DI-51-52)
- Stainless Steel adapter plates (pg DI-51-52)
- **CP** - Cover Plate with handles, S/S
- **2060-1** - Condensate Evaporator
- **RS** - Remote on/off switch for counter mounting
- **RDVE** - Rear Drain Valve Extension
- * **220 Volt - 50 Cycle** Compressor

These units have not been performance tested for use with potentially hazardous foods, and must be used with ice.

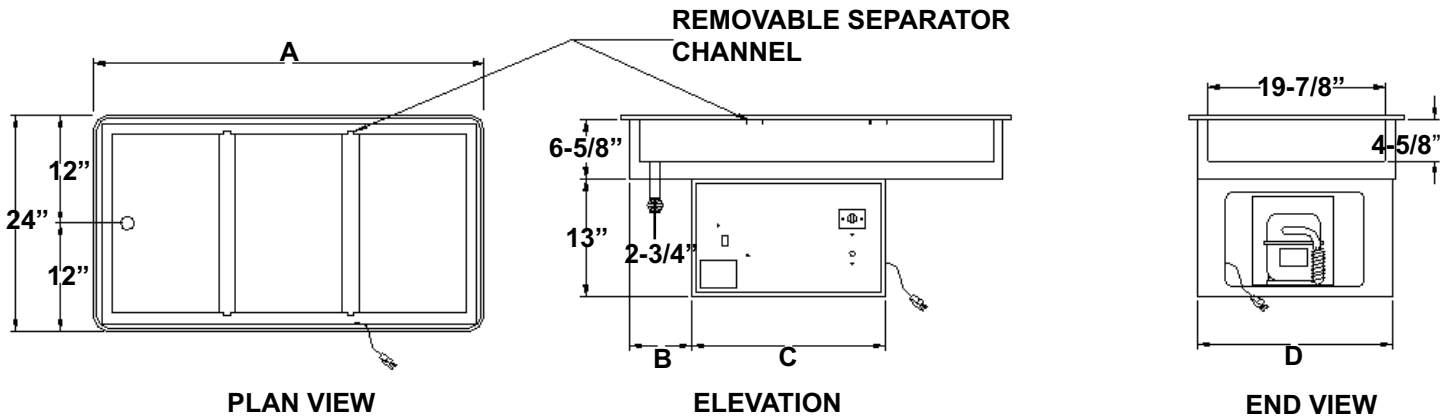

*Drain Location on 16" Dimension

MODEL	PAN OPENINGS	PAN SIZE	"A"	ELECTRICAL CHARACTERISTICS	CUT-OUT REQUIRED	SHIP WT. (LBS.)
*WCM-1	1	19-7/8" X 11-3/4" X 4-5/8" (50.4 X 29.8 X 11.7cm)	16" (40.6cm)	2.4 amps. - 120V - 1/5HP	22-1/4" X 14-1/4" (56.5 X 36.1cm)	116 (52.6kg)
WCM-2	2	19-7/8" X 25-1/2" X 4-5/8" (50.4 X 64.7 X 11.7cm)	29-3/4" (75.2cm)	3.9 amps. - 120V - 1/5HP	22-1/4" X 28" (56.5 X 71.1cm)	164 (74.4kg)
WCM-3	3	19-7/8" X 39-1/4" X 4-5/8" (50.4 X 99.6 X 11.7cm)	43-1/2" (110.4cm)	3.9 amps. - 120V - 1/5HP	22-1/4" X 41-3/4" (56.5 X 106cm)	198 (89.8kg)
WCM-4	4	19-7/8" X 53" X 4-5/8" (50.4 X 134.6 X 11.7cm)	57-1/4" (145.4cm)	6.8 amps. - 120V - 1/4HP	22-1/4" X 55-1/2" (56.5 X 140.9cm)	226 (102.5kg)
WCM-5	5	19-7/8" X 66-3/4" X 4-5/8" (50.4 X 169.5 X 11.7cm)	71" (180.3cm)	9.8 amps. - 120V - 1/3HP	22-1/4" X 69-1/4" (56.5 X 175.8cm)	262 (118.8kg)
WCM-6	6	19-7/8" X 80-1/2" X 4-5/8" (50.4 X 204.4 X 11.7cm)	84-3/4" (215.2cm)	9.8 amps. - 120V - 1/3HP	22-1/4" X 83" (56.5 X 210.8cm)	316 (143.3kg)

	B	C	D
WCM-1	3-7/8" (9.8cm)	18" (45.7cm)	13-3/4" (34.9cm)
WCM-2	5-5/8" (15.2cm)	21-1/2" (54.6cm)	21-5/8" (54.9cm)
WCM-3	7" (17.7cm)	21-1/2" (54.6cm)	21-5/8" (54.9cm)
WCM-4	7" (17.7cm)	21-1/2" (54.6cm)	21-5/8" (54.9cm)
WCM-5	7" (17.7cm)	21-1/2" (54.6cm)	21-5/8" (54.9cm)
WCM-6	7" (17.7cm)	21-1/2" (54.6cm)	21-5/8" (54.9cm)

REMOTE REFRIGERATION MODEL	LESS COMP. SHIP WT. (LBS.)
WCMX-1	74 (33.5kg)
WCMX-2	120 (54.4kg)
WCMX-3	153 (69.3kg)
WCMX-4	168 (76.2kg)
WCMX-5	209 (94.8kg)
WCMX-6	264 (119.7kg)

WCMX - REFRIGERATED COLD PAN WITHOUT COMPRESSOR

Units include Refrigerated Cold Pan, Thermostat, Cap Tube & Drier (for hook up in field by others)

COMPRESSORS FOR REMOTE INSTALLATIONS

2029 - 1/5 HP for WCMX-1, 2, & 3
2029-1 - 1/4 HP for WCMX-4
2029-2 - 1/3 HP for WCMX-5 & 6

MECHANICAL COLD PANS

WCM/WCMD/WCMDC/WCML/WCMDL & WCMDCL SERIES

INSTALLATION

Provide the correct counter cut-out opening (see chart below) and drop in. The vinyl gasket assures complete seating. A non-toxic silicone seal may be used between the gasket and counter top (not required).

Note: Units are supplied with a nipple and stop valve to be connected for draining.

MODEL NUMBER	CUT-OUT SIZE
WCM/ WCMD & WCMDC-1	22 1/4 X 14 1/4
WCM/ WCMD & WCMDC-2	22 1/4 X 28
WCM/ WCMD & WCMDC-3	22 1/4 X 41 3/4
WCM/ WCMD & WCMDC-4	22 1/4 X 55 1/2
WCM/ WCMD & WCMDC-5	22 1/4 X 69 1/4
WCM/ WCMD & WCMDC-6	22 1/4 X 83
WCML/ WCMDL & WCMDCL-2	14 1/4 X 44 1/4
WCML/ WCMDL & WCMDCL-3	14 1/4 X 66
WCML/ WCMDL & WCMDCL-4	14 1/4 X 87 3/4

The unit should be level for draining purposes. When installing unit in a counter, it is recommended that the operator side of the counter be completely open for air circulation. When this is not possible, such as in an island counter, it is recommended that two grill openings are provided approximately 18" x 18" of free air for intake and exhaust at the opposite ends of the counter.

The unit is supplied with a power cord and NEMA plug. Refer to the data plate on the compressor housing for the amperage and voltage information. Use a licensed electrician when installing power source.

OPERATION

This unit should be turned on one hour before serving and turned off after completing the serving period. The thermostat has an off position and numbers from 1 through 7, (number 7 is the coldest). **Note: The unit should not operate 24/7.**

MAINTENANCE

NEVER CLEAN PANS WITH A CHLORIDE BASED PRODUCT. CHLORIDES OR IMPROPER CLEANING COULD SCAR, MARK AND/OR CORRODE PANS. **DO NOT** USE STEEL WOOL OR ABRASIVE PRODUCTS. TO CLEAN USE SOAPY WARM WATER, RINSE THOROUGHLY TO REMOVE ALL RESIDUES. **FAILURE TO MEET THESE CONDITIONS WILL VOID WARRANTY.**
CLEAN CONDENSER COIL REGULARLY.

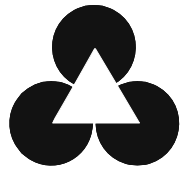

Atlas Metal INDUSTRIES, INC.

Subsidiary of Mercury Aircraft, Inc.

1135 N.W. 159th DR., MIAMI, FL 33169
 PHONE (305) 625-2451, (800) 762-7565, FAX (305) 623-0475, E-mail: sales@atlasfoodserv.com

PARTS LIST FOR MECHANICAL COLD PANS WCM/WCMD/WCMDC/WCML/WCMDL & WCMDCL SERIES

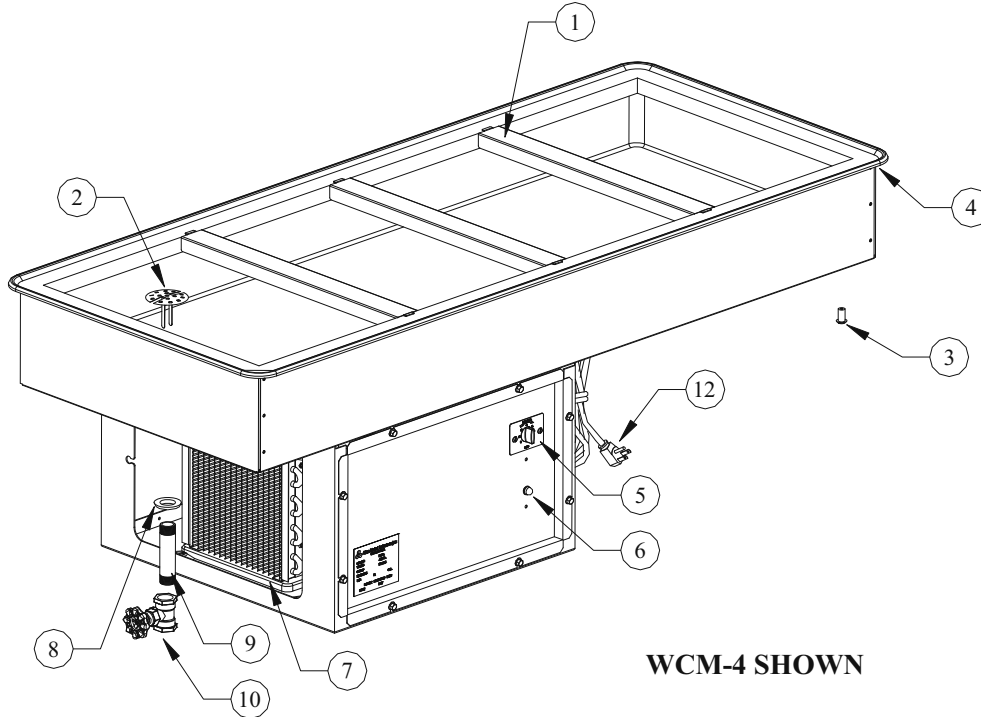

WCM-4 SHOWN

ITEM NUMBER	PART NUMBER	DESCRIPTION
1	S80103-0	Separator Channel (WCM & WCMD)
1	S85008-0	Separator Channel (WCML & WCMDL)
2	86-3202	Perforated Snap- In Drain
3	7020-0	Nylon Spacer
4	7002-0+Model #	Vinyl Bead Gasket
5	2044-0	Thermostat
6	112-1101	Pilot Light (BLUE)
7	2029-0	1/5 H.P. Compressor (WCM-WCMD-WCMDC-1-2-3-WCML-WCMDL-WCMDCL-2-3)
7	2029-1	1/4 H.P. Compressor (WCM-WCMD-WCMDC-WCMDL-WCMDCL-4)
7	2029-2	1/3 H.P. Compressor (WCM-WCMD-WCMDC-5-6)
8	49-1028	Grommet
9	30-3130	3/4 " x 4" PVC Nipple
10	3016-2	Stop Valve
11	7041-0	Power Cord Bushing (Not Shown)
12	1003-0	Power Cord
13	2025	Drier (Not Shown)
14	2026	0.042 Cap Tube for 1/4, 1/3 & 1/2 Compressor (Not Shown)
15	2027	0.031 Cap Tube for 1/5 Compressor only (Not Shown)
16	600008	Thermostat Knob



Atlas Metal
INDUSTRIES, INC.

A subsidiary of Mercury Aircraft, Inc

1135 N.W. 159th DRIVE, MIAMI, FLORIDA 33169

TEL.: (305) 625-2451 TOLL FREE (800) 762-7565 FAX: (305) 623-0475

Web Page: www.atlasfoodserv.com E-Mail: sales@atlasfoodserv.com

Project: _____

Item No.: _____

Quantity: _____

DROP-IN SERVING EQUIPMENT



HOT/COLD PAN

Dual Temp.
Hot or Cold Service
(For Hot Mode)
Water Must Be Used

- WCM-HP-2**
- WCM-HP-3**
- WCM-HP-4**
- WCM-HP-5**
- WCM-HP-6**

WCM-HP-3

SPECIFICATIONS

TOP: Constructed of 18 gauge, type 304 stainless steel, die stamped with a raised perimeter bead. There shall be a solid vinyl gasket under the beaded edge to form a seal to the counter top, thus preventing seepage or marring of the counter top. Embossed mounting lugs are provided along the inner surface of the top to hold a full set of removable separator channels in place.

LINER: The inner liner shall be 18 gauge, type 304 stainless steel, one piece construction, all welded, ground and polished to a uniform finish. All corners are covered with a minimum 1/4" radius. The liner has copper tubing firmly soldered to the exterior sides. A 3/4" dia. drain with strainer, 4" copper nipple, and valve is provided.

INSULATION: The pan is fully insulated with high density fiberglass, 1-3/8" thick on all sides, 1-1/2" thick on the bottom and enclosed with a 22 gauge galvanized steel outer case.

HEATING ELEMENT: An immersion type heating element is provided in the bottom of the pan along with a perforated stainless steel sheath cover. A thermostat control is included. **Please note: the element must be submerged in water to operate properly.**

REFRIGERATION SYSTEM: The compressor housing shall be fabricated from 14 gauge galvanized angles and bolted to the base of the unit. A fully self-contained condensing unit is provided with a hermetically sealed compressor and a thermostat control. The system is fully charged with CFC free refrigerant and ready to operate.

NOTE: Proper ventilation must be provided in counter.

ELECTRICAL: The unit is pre-wired with a hot/cold selector switch that prevents dual operation, with the required thermostat controls and pilot light. The unit is provided with a 6' long, 3-wire cord and a twist lock plug.

Specifications subject to change without notice.

STANDARD FEATURES

- Dual Temp. - a hot serving unit becomes a refrigerated cold pan at the flip of a switch
- Fully insulated for energy savings
- Factory applied gasket - makes installation a snap and seals units to the counter top, thus eliminating seepage
- Accommodates standard 12" X 20" pans with the use of separator channel(s), or fractional size pans with the use of optional adapter bars.
- 1-Year Parts & Labor Warranty
- NSF Certified; ULRecognized

ACCESSORIES

- **5YW** - 5-Year Compressor Warranty
- Stainless Steel adapter bars (pg DI-51-52)
- Stainless Steel adapter plates (pg DI-51-52)
- **CP** - Cover Plate with handles, S/S
- **RSHP** - Remote Switch for counter mounting
- **RDVE** - Rear Drain Valve Extension
- **AF** - Automatic water fill
- * **220 Volt - 50 Cycle** Compressor

*Please see Operation & Installation Manual for ALL operation and maintenance details.

* Units with these accessories are not currently UL listed.

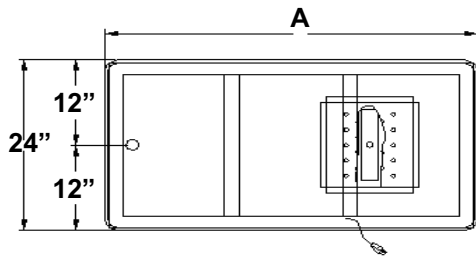

PLAN VIEW

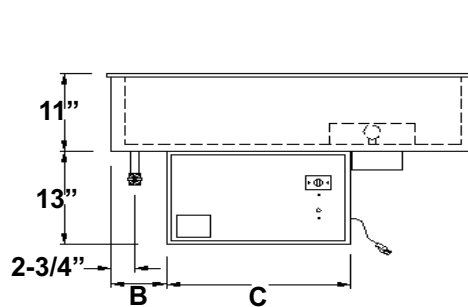

ELEVATION

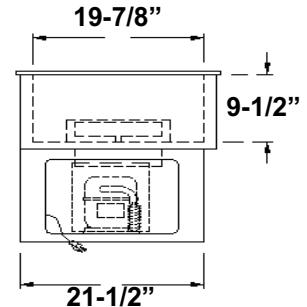

END VIEW

MODEL	"A"	PAN SIZE	ELECTRICAL CHARACTERISTICS		NEMA CONFIGURATION	SHIP WT. (LBS.)
			HOT OPERATION	COLD OPERATION		
WCM-HP-2	29-3/4" (75.5cm)	19-7/8" X 25-1/2" X 9-1/2" (50.4 X 64.7 X 24.1cm)	16.7 amps. - 2KW - 120V	2.4 amps. - 120V - 1/5 HP	L5-30P	189 (85.7kg)
WCM-HP-3	43-1/2" (110.4cm)	19-7/8" X 39-1/4" X 9-1/2" (50.4 X 99.6 X 24.1cm)	16.7 amps. - 2KW - 120V	2.4 amps. - 120V - 1/5 HP	L5-30P	219 (99.3kg)
WCM-HP-4	57-1/4" (145.4cm)	19-7/8" X 53" X 9-1/2" (50.4 X 134.6 X 24.1cm)	14.4 amps. - 3KW - 208V 12.5 amps. - 3KW - 240V	7.5 amps. - 120V - 1/4 HP 7.5 amps. - 120V - 1/4 HP	L14-30P L14-30P	255 (115.7kg)
WCM-HP-5	71" (180.3cm)	19-7/8" X 66-3/4" X 9-1/2" (50.4 X 169.5 X 24.1cm)	19.3 amps. - 4KW - 208V 16.7 amps. - 4KW - 240V	9.8 amps. - 120V - 1/3 HP 9.8 amps. - 120V - 1/3 HP	L14-30P L14-30P	268 (121.6kg)
WCM-HP-6	84-3/4" (215.2cm)	19-7/8" X 80-1/2" X 9-1/2" (50.4 X 204.4 X 24.1cm)	19.3 amps. - 4KW - 208V 16.7 amps. - 4KW - 240V	9.8 amps. - 120V - 1/3 HP 9.8 amps. - 120V - 1/3 HP	L14-30P L14-30P	336 (152.4kg)

* Units are wired to prevent simultaneous operation in the hot and cold mode. Numeral following the model letters denotes the 12" x 20" pan capacity.

COUNTER CUT-OUT REQUIRED	
2	23-1/4" X 28-3/4" (59 X 73cm)
3	23-1/4" X 42-1/2" (59 X 107.9cm)
4	23-1/4" X 56-1/4" (59 X 142.8cm)
5	23-1/4" X 70" (59 X 177.8cm)
6	23-1/4" X 83-3/4" (59 X 212.7cm)

	B	C
WCM-HP-2	4-3/8" (11cm)	14" (35.5cm)
WCM-HP-3	6-1/2" (16.5cm)	21-1/2" (54.6cm)
WCM-HP-4	6-1/2" (16.5cm)	21-1/2" (54.6cm)
WCM-HP-5	6-1/2" (16.5cm)	21-1/2" (54.6cm)
WCM-HP-6	6-1/2" (16.5cm)	21-1/2" (54.6cm)

REMOTE REFRIGERATION MODEL	LESS COMP. SHIP WT. (LBS.)
WCM-HPX-2	148 (67.1kg)
WCM-HPX-3	178 (80.7kg)
WCM-HPX-4	208 (94.3kg)
WCM-HPX-5	222 (100.7kg)
WCM-HPX-6	290 (131.5kg)

WCM-HPX - HOT/COLD PAN WITHOUT COMPRESSOR

Units include Hot/Cold Pan, Thermostat, Cap Tube & Drier (for hook up in field by others)

COMPRESSORS FOR REMOTE INSTALLATIONS

2029 - 1/5 HP for WCM-HPX-2, & 3
2029-1 - 1/4 HP for WCM-HPX-4
2029-2 - 1/3 HP for WCM-HPX-5 & 6

RSHP - Remote Control Panel is required to operate unit.

HOT OR REFRIGERATED COLD PAN

WCM-HP SERIES

INSTALLATION

Provide the correct counter cut-out opening (see chart below, a 1" radius is required for each corner) and drop in. The vinyl gasket assures complete seating. A non-toxic silicone seal may be used between the gasket and counter top (not required).

Note: Units are supplied with a nipple and stop valve to be connected for draining.

MODEL	CUT-OUT SIZE
WCM-HP-2	23 1/4 X 28 3/4
WCM-HP-3	23 1/4 X 42 1/2
WCM-HP-4	23 1/4 X 56 1/4
WCM-HP-5	23 1/4 X 70
WCM-HP-6	23 1/4 X 83 3/4

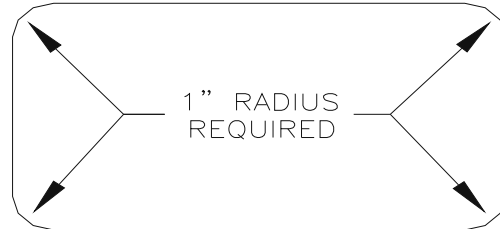

The unit should be level for draining purposes. When installing unit in a counter, it is recommended that the operator side of the counter be completely open for air circulation. When this is not possible, such as in an island counter, it is recommended that two grill openings are provided, approximately 18" x 18" of free air for intake and exhaust, at the opposite ends of the counter.

The unit is supplied with a power cord and NEMA plug. Refer to the data plate on the compressor housing for the amperage and voltage information. Use a licensed electrician when installing power source.

"Waste water connections are to conform to the International Plumbing Code 2003, International Code Council (ICC) or the Uniform Plumbing Code 2003, International Association of Plumbing and Mechanical Officials (IAPMO)" or the equivalent.

OPERATION

HEATING CYCLE

- 1-Turn master switch to "OFF" position.
- 2-Close drain valve.
- 3-Fill unit, preferably with "HOT" water until heating element is completely submerged (water must be level or above the water fill line). **"WARNING": HEATING ELEMENT WILL BE DAMAGED IF NOT SUBMERGED AT ALL TIMES DURING HEATING CYCLE.** Check water level before heating operation and approximately every 4 hours of continuous operation. Failure to do so will void warranty.
- 4-Turn selector switch to "HOT".
- 5-Turn master switch to "ON".
- 6-Select desired setting on heating thermostat dial (1-Warm, 10-Hot).
- 7-Cover unit with serving pans. Unit will be ready for serving in approximately 30 minutes.

HEATING TO COOLING

- 1-Turn master switch to "OFF" position.
 - 2-Remove serving pans.
 - 3-Drain hot water completely.
 - 4-Turn selector switch to "COLD".
 - 5-Turn master switch to "ON".
"CAUTION": Unit is equipped with a safety device. Cold cycle will not energize until the stainless liner temperature is at 120 degrees or below.
 - 6-Select desired cooling thermostat setting, (1 cool, 7 coldest).
 - 7-Cover unit with serving pans. Unit will cool down and be ready for serving in approximately 30 minutes
- *Unit is not intended to operate 24/7.

COOL TO HEAT

Follow same steps shown for heat cycle.

MAINTENANCE

NEVER CLEAN PANS WITH A CHLORIDE BASED PRODUCT. CHLORIDES OR IMPROPER CLEANING COULD SCAR, MARK AND/OR CORRODE PANS. **DO NOT** USE STEEL WOOL OR ABRASIVE PRODUCTS. TO CLEAN USE SOAPY WARM WATER, RINSE THOROUGHLY TO REMOVE ALL RESIDUES.

CLEAN CONDENSER COIL REGULARLY.

HEATER SHEATH SHOULD BE PERIODICALLY CLEANED OF LIME OR OTHER BUILT-UP MATERIAL TO PREVENT ELEMENT OVER HEATING.

FAILURE TO MEET THESE CONDITIONS WILL VOID WARRANTY.



Atlas Metal INDUSTRIES, INC.

Subsidiary of Mercury Aircraft, Inc.

1135 N.W. 159th DR., MIAMI, FL 33169

PHONE (305) 625-2451, (800) 762-7565, FAX (305) 623-0475, E-mail: sales@atlasfoodserv.com

PARTS LIST HOT OR COLD COMBINATION UNIT WCM-HP SERIES

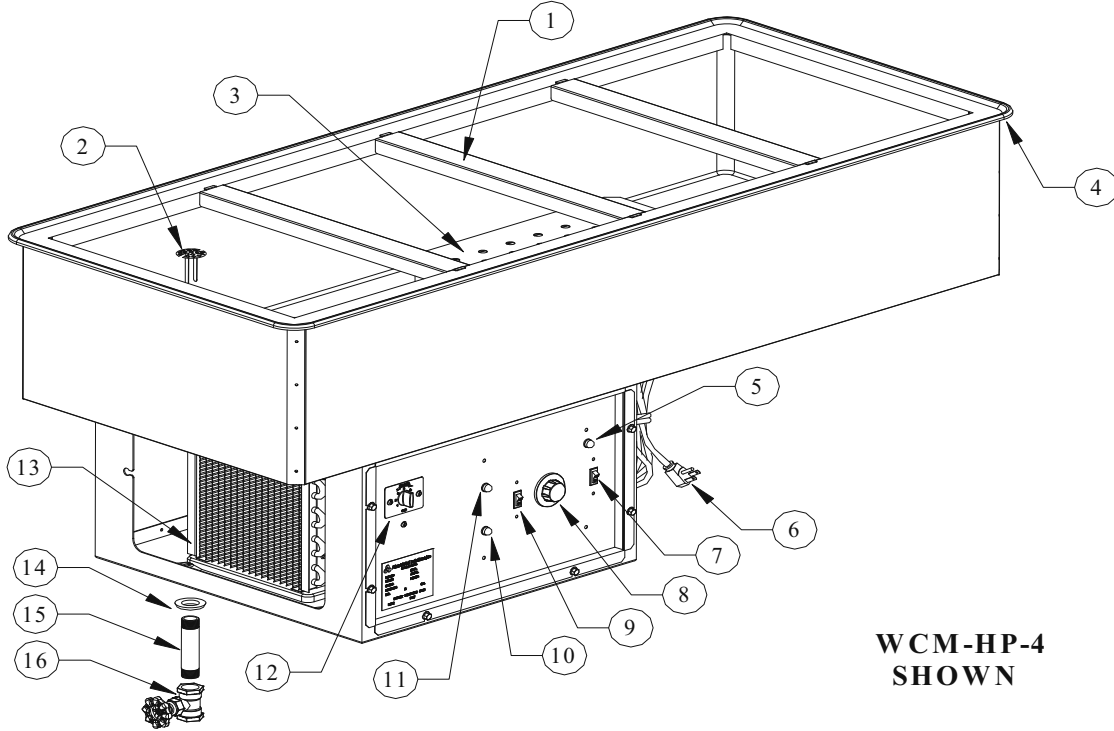

**WCM-HP-4
SHOWN**

ITEM NUMBER	PART NUMBER	DESCRIPTION
1	S80103-0	Separator Channel
2	86-3202	Perforated Snap-In Drain
3	S80608-0	Element Cover (Units 4, 5, 6)
	S80607-0	Element Cover (Units 2, 3)
4	7002-0+Model #	Vinyl Bead Gasket
5	1100	Master Pilot Light (Red)
6	1004-0	12/3 S.O. Power Cord with Plug
	1004-4	10/3 Power Cord with Plug
7	12-202	Master Switch PS30AC2-I
8	22-1402	Heating Thermostat
9	112-1252	Manuel Control P&S 1228
10	112-1101	Cooling Pilot Light (Blue)
11	1100	Heating Pilot Light (Red)
12	2044-0	Cooling Thermostat
13	2029-0	1/5 H.P. Compressor (WCMHP-2 & 3)
	2029-1	1/4 H.P. Compressor (WCMHP-4)
	2029-2	1/3 H.P. Compressor (WCMHP-5 & 6)
14	49-1028	Grommet
15	3006-2	3/4 " x 4" Brass Nipple
16	3016-1	Brass Stop Valve

ITEM NUMBER	PART NUMBER	DESCRIPTION
17	22-99	Safety Switch (Not Shown)
18	111-1069	Heating Elem. 120V 2000W (WCMHP-2 & 3) (Not Shown)
	111-1062	Heating Elem. 208V 3000W (WCMHP-4) (Not Shown)
	111-1063	Heating Elem. 208V 4000W (WCMHP-5 & 6) (Not Shown)
	111-1060	Heating Elem. 240V 3000W (WCMHP-4) (Not Shown)
19	111-1061	Heating Elem. 240V 4000W (WCMHP-5 & 6) (Not Shown)
	2691-3	30 Amps. 120/250 Volt Plug; WCMHP-4, 5, 6, RMHP-4, 5, 6 (Not Shown)
	12-256	30 Amps. 120 Volt Plug; WCMHP-2, 3; RMHP-2, 3 (Not Shown)
20	2025-0	Drier (Not Shown)
21	2026-0	0.042 Cap Tube for 1/4, 1/3 & 1/2 Compressor (Not Shown)
22	2027-0	0.031 Cap Tube for 1/5 Compressor only (Not Shown)
23	S80609	Thermostat Cover w/Wire Nuts
24	112-1103	Amber pilot light (Not Shown)

AUTOMATIC WATER FILL UNITS

WIH, WH AND WCMHP/RMHP SERIES

INSTALLATION

When installing water supply to the unit, the supply lines must be purged to remove particles from damaging the solenoid valve operation. A factory supplied in-line water strainer is installed. However, it is recommended the customer supply a primary water filtering system for protection.

***Note-Atlas Metal Ind. Inc. is not responsible for routine maintenance of the strainer or customer supplied water filter system.**

***Atlas Metal Industries Inc. recommends that all units installed to a water source use our Autofill or any backflow protection of your choice. Please refer to your local code.**

Any attempt to change or modify the Auto Fill system will void the warranty.

OPERATION

To operate the Auto Fill system, turn the Auto-fill On/Off switch, located on the control panel, to the On position. Allow water to complete filling the pan to the water level mark before energizing the heating cycle.

***Note -** Factory water depth settings for A/F units are 1/4" for WIH, 1/2" for WH & WCMHP/RMHP are 1/2" above the heating element cover.

DO NOT manually add water to Auto-fill units above water level mark, damage and leakage to the Automatic sensor could result. As the water evaporates the pans will fill automatically. **It is recommended that the Auto Fill be in the off position when not in use.**

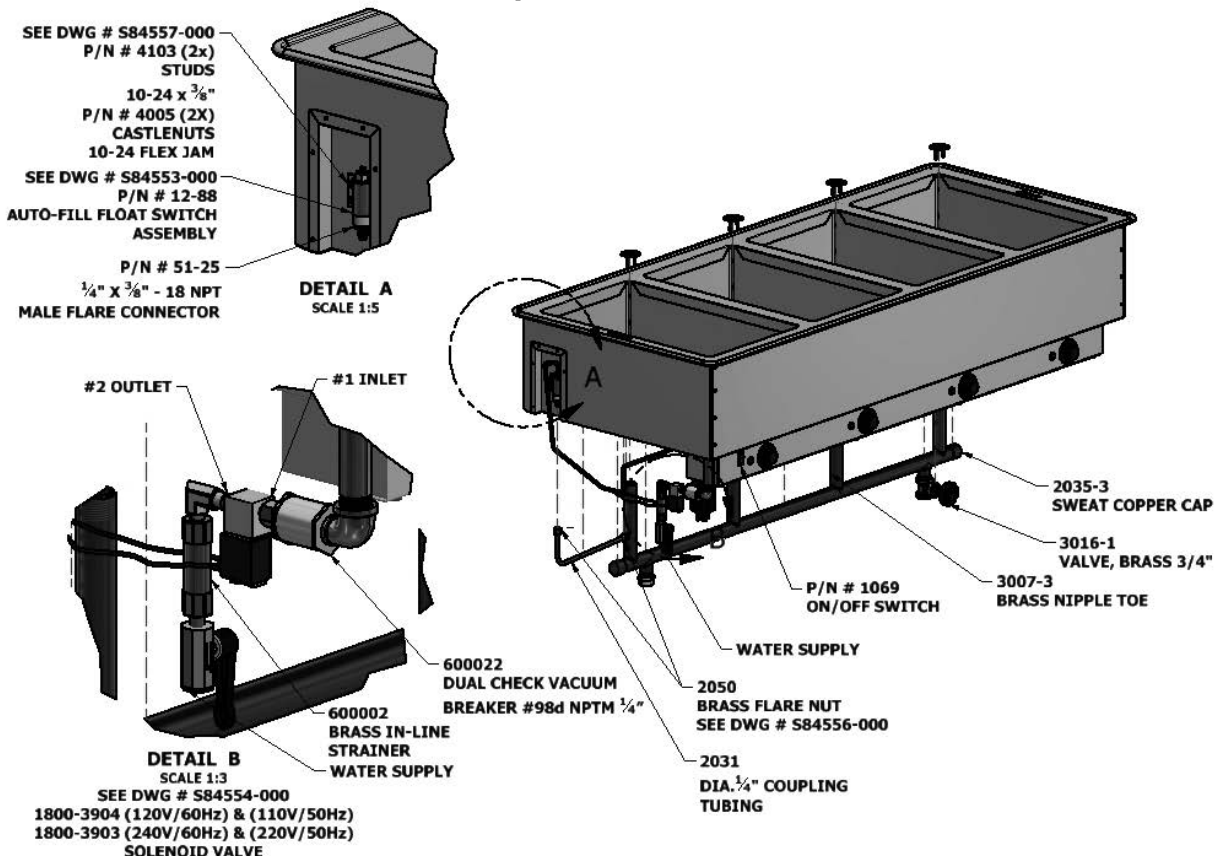

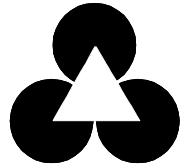

Atlas Metal INDUSTRIES, INC.

Subsidiary of Mercury Aircraft, Inc.

1135 N.W. 159th DR., MIAMI, FL 33169

PHONE (305) 625-2451, (800) 762-7565, FAX (305) 623-0475, E-mail: sales@atlasfoodserv.com

Refrigerated Drop-In Trouble Shooting Guide	
Symptom	Probable Cause
Unit will not run	Unit not plugged in. No power at receptacle. Thermostat and or switch not in the on position. Unit may be in a defrost cycle (if supplied) wait approximately 20 min. Call factory for service at 1-800-762-7565
Condenser runs but short cycles	Condenser coil dirty Inadequate ventilation. Call factory for service at 1-800-762-7565
Condenser runs constantly.	Condenser coil dirty. Inadequate ventilation. Unit installed in a hot location Call factory for service at 1-800-762-7565 NOTE: WF series runs constantly.
Food product not cold enough.	Food product must be chilled to 33-35 deg. when placed in unit. Air movement over food product. Food product not being stirred or rotated. Call factory for service at 1-800-762-7565

ELECTRICAL & REFRIGERATION CHART

<u>Model</u>	<u>Volts</u>	<u>Amps.</u>	<u>Watts</u>	<u>HP</u>	<u>Ref.</u>	<u>Oz.</u>	<u>Low</u>	<u>High</u>	<u>BTU@</u>
							<u>psig.</u>	<u>psig.</u>	<u>M10 90A</u>
WCM-1	120	2.4		1/5	134A	4	5	150	505
WCM-2	120	3.9		1/5	134A	5.5	5	150	505
WCM-3	120	3.9		1/5	134A	7	10	155	505
WCM-4	120	6.8		1/4	134A	9	8	155	1070
WCM-5	120	9.8		1/3	134A	11	9	150	1285
WCM-6	120	9.8		1/3	134A	12	8	155	1285
WCMC-1	120	2.4		1/5	134A	4	7	150	505
WCMC-2	120	3.9		1/5	134A	5	8	155	505
WCMC-3	120	3.9		1/5	134A	6	8	155	505
WCMC-4	120	6.8		1/4	134A	8	10	155	1070
WCMC-5	120	9.8		1/3	134A	10	9	155	1285
WCMC-6	120	9.8		1/3	134A	11	10	155	1285
WCMD-1	120	2.4		1/5	134A	4	7	150	505
WCMD-2	120	3.9		1/5	134A	5	8	155	505
WCMD-3	120	3.9		1/5	134A	6	8	155	505
WCMD-4	120	6.8		1/4	134A	8	10	155	1070
WCMD-5	120	9.8		1/3	134A	10	9	155	1285
WCMD-6	120	9.8		1/3	134A	11	10	155	1285
WCMDC-1	120	2.4		1/5	134A	4	8	155	505
WCMDC-2	120	3.9		1/5	134A	5	13	160	505
WCMDC-3	120	3.9		1/5	134A	6	10	159	505
WCMDC-4	120	6.8		1/4	134A	8	10	156	1070
WCMDC-5	120	9.8		1/3	134A	10	10	156	1285
WCMDC-5	120	9.8		1/3	134A	11	9	155	1285
WCML-2	120	3.9		1/5	134A	5	8	150	505
WCML-3	120	3.9		1/5	134A	9	8	155	505
WCML-4	120	6.8		1/4	134A	8	7	180	1070
WCMDL-2	120	3.9		1/5	134A	5	8	155	505
WCMDL-3	120	3.9		1/5	134A	9	8	155	505
WCMDL-4	120	6.8		1/4	134A	8	10	155	1070
WCMHP-2	120	2.3/16.7	2000	1/5	134A	5	8	155	505
WCMHP-3	120	2.3/16.7	2000	1/5	134A	6	8	157	505
WCMHP-4	120/208	9.8/14.5	3000	1/4	134A	10	10	159	1070
WCMHP-4	120/240	9.8/13	3000	1/3	134A	10	10	160	1070
WCMHP-5	120/208	9.8/19.3	4000	1/2	134A	10	10	160	1285
WCMHP-5	120/240	9.8/16.7	4000	1/2	134A	10	10	160	1285
WCMHP-6	120/208	9.8/19.3	4000	1/2	134A	11	10	160	1285
WCMHP-6	120/240	9.8/16.7	4000	1/2	134A	11	10	160	1285

8 7 6 5 4 3 2 1

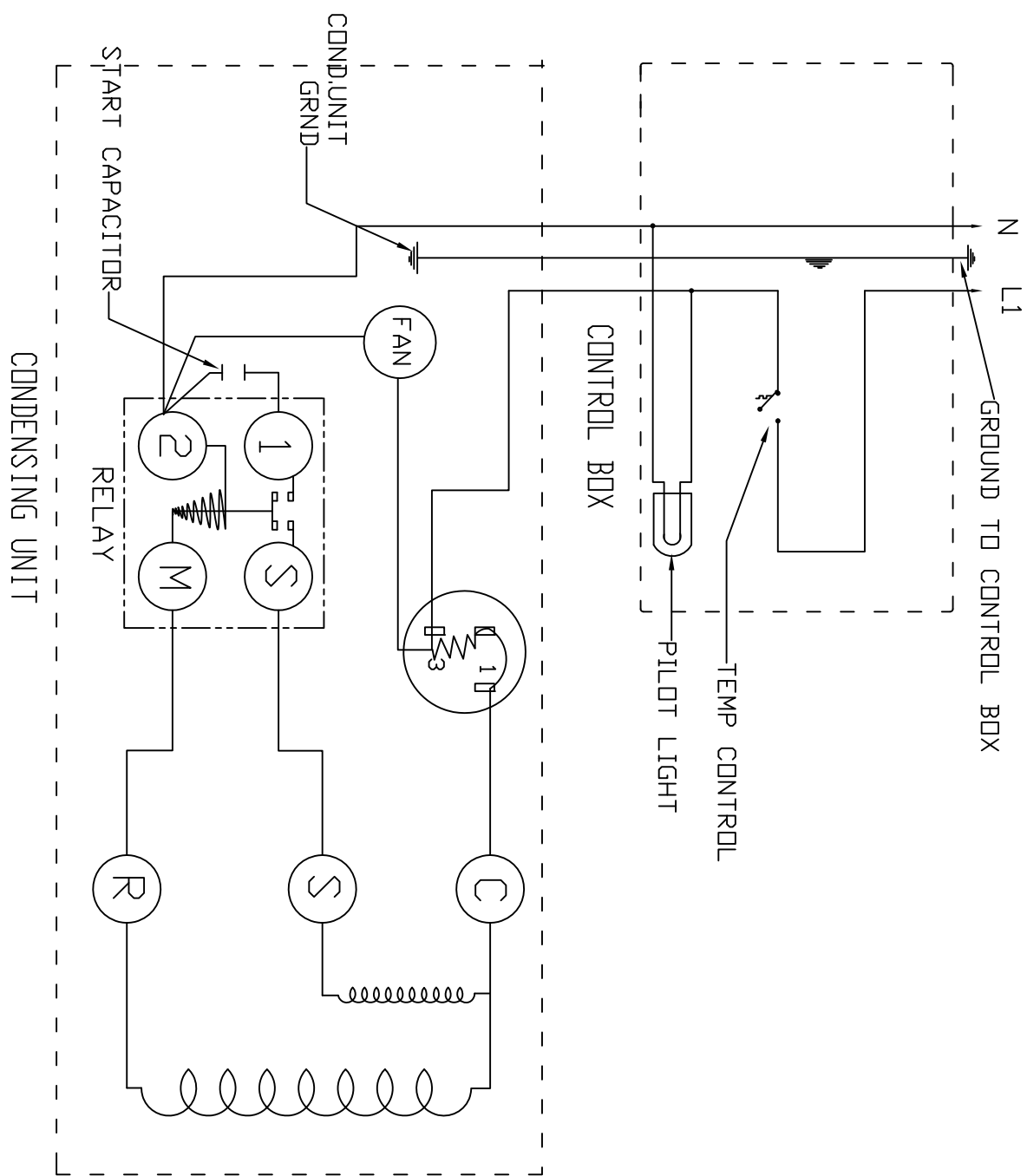

120 VOLTS

- WCM-1-----1/5 H. P.
- WCMDC-1-----1/5 H. P.
- WCM-2-3-----1/5 H. P.
- WCMDC-2-3-----1/5 H. P.
- WCM-4-----1/4 H. P.
- WCMDC-4-----1/4 H. P.
- WCM-5-6-----1/3 H. P.
- WCMDC-5-6-----1/3 H. P.
- WDFL-----1/5 H. P.
- WDF-2-3-----1/4 H. P.
- WCPM-----1/5 H. P.
- WCRM-----1/5 H. P.
- WCML-2-3-----1/5 H. P.
- WCML-4-----1/4 H. P.
- WCMDL-2-3-----1/5 H. P.
- WCMDL-4-----1/4 H. P.
- WCMC 1-2-3-----1/5 H. P.
- WCMD 1-2-3-----1/5 H. P.
- WCMDCL-2-3-----1/5 H. P.
- WCMD-4-----1/4 H. P.
- WCMD-5-6-----1/3 H. P.

These plans are the exclusive property of Atlas Metal Industries Inc. Any unauthorized use without written consent of Atlas Metal Industries Inc., is strictly prohibited.

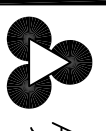

ATLAS METAL INDUSTRIES, INC.
1135 NW 159TH DRIVE
MIAMI, FLORIDA 33169

REVISION CHANGES

DATE:	DESCRIPTION:	DATE:	DRAWN BY:
9-18-09	ON CAD	9-18-09	MHA
			MHA
			N.SANZ

WCM-WCMD-WCML-WCMDL-WDF-WDFL
ELECTRICAL SCHEMATIC
120VOLTS (1) PHASE
DRAWING No.
WCM-WCMD ELECTRICAL SCHEMATIC

SCALE 3/4"=1'
SHEET NO. 1 of 1

A B C D

A B C D

8 7 6 5 4 3 2 1

WCM-HP-2/3-----1/5 H.P.

120/120 VOLTS 1 PHASE COLD/HOT

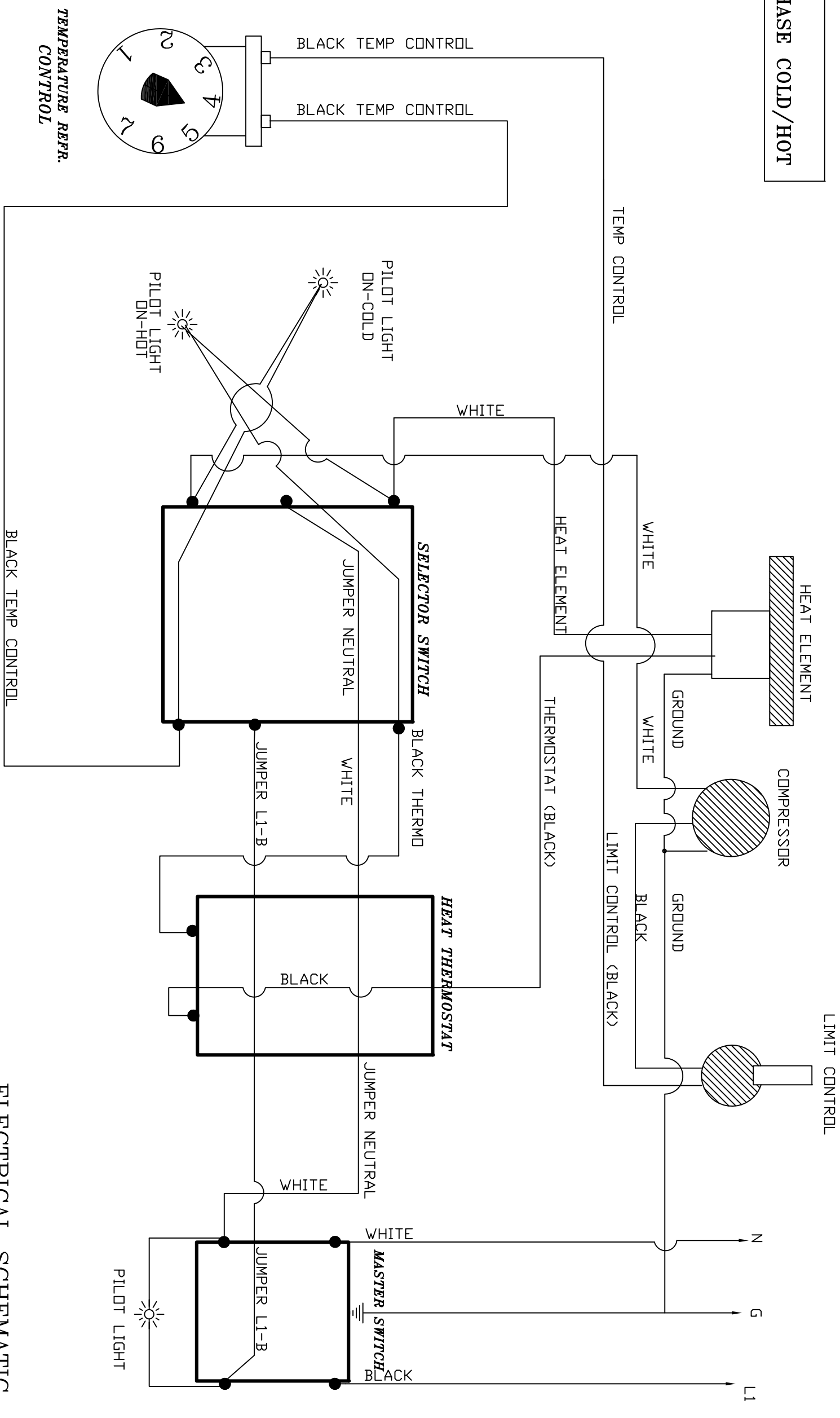

ELECTRICAL SCHEMATIC

These plans are the exclusive property of Atlas Metal Industries Inc. Any unauthorized use without written consent of Atlas Metal Industries Inc., is strictly prohibited.

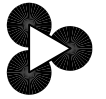

ATLAS METAL INDUSTRIES, INC.
1135 NW 159TH DRIVE
MIAMI, FLORIDA 33169

REVISION CHANGES		DATE:	DATE:
DESCRIPTION:	UPDATED	9-2-10	12-1-09
	(NEW SELECTOR SWITCH)	MHA	MHA
			CHECKED BY: N.SANZ

DRAWING NO.	WCM-HP-2-3
ELECTRICAL SCHEMATIC	
SCALE	3/4"=1'
SHEET NO.	1 of 1

8 7 6 5 4 3 2 1

WCM-HP-4---1/4 H.P.
 WCM-HP-5-6---1/3 H.P.

120/208/240 VOLTS 1 PHASE COLD/HOT

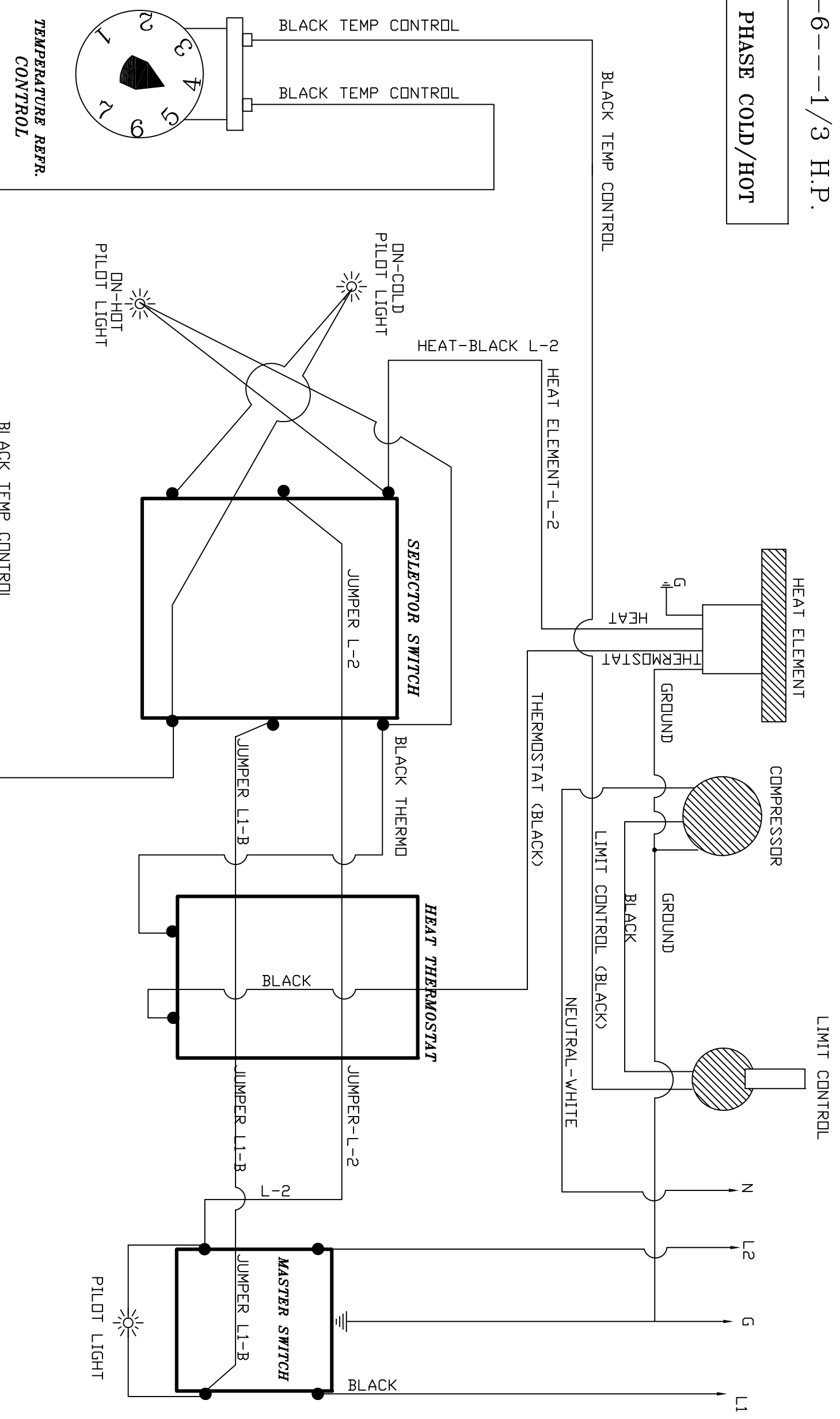

ELECTRICAL SCHEMATIC

These plans are the exclusive property of Atlas Metal Industries Inc. Any unauthorized use without written consent of Atlas Metal Industries Inc., is strictly prohibited.



ATLAS METAL INDUSTRIES, INC.
 1135 NW 159TH DRIVE
 MIAMI, FLORIDA 33169

REVISION CHANGES		DATE:	DATE:	DRAWING NO.	SHEET NO. 1 of 1
DATE:	DESCRIPTION:	BY:	CHECKED BY:		
9-2-10	UPDATED	MHA	N.SANZ	WCM-HP 4-5-6--120/208/240V	SCALE 3/4"=1'
		MHA			

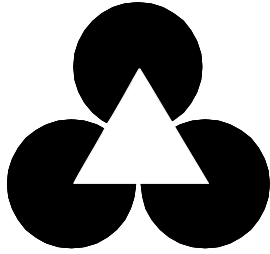

Atlas Metal
INDUSTRIES, INC.

LIMITED WARRANTY

Atlas Metal Industries, Inc. warrants to the Purchaser of this product that the same shall be free from defects in the workmanship and material for a period of one year from the date of original installation of the equipment, but not to exceed eighteen (18) months after date of shipment from factory. During this period of time Atlas Metal Industries, Inc. will replace all defective parts and will pay for authorized replacement labor. Replacement and installation of such parts and labor shall be provided only upon prior written authority of Atlas Metal Industries, Inc.

The Refrigeration warranty is for a twenty (20) month time period and includes supplying the compressor at a no charge basis provided the damage to the compressor was not caused by the customer or end user. Authorized replacement labor will be paid for a period of one year from date of installation. Freight costs for defective unit to and from Atlas Metal Industries, Inc. are not included, and all defective parts must be returned to the factory freight prepaid for evaluation. **ALL WARRANTY LABOR MUST BE AUTHORIZED BY ATLAS METAL INDUSTRIES, INC. PRIOR TO THE ACTUAL WORK BEING DONE.** This warranty does not apply to any equipment or any part thereof, which has been subjected to shipping damage, improper voltage, alteration, abuse or misuses, and does not cover loss of food, other products, or damage to property due to mechanical or electrical malfunction.

THERE ARE NO WARRANTIES WHICH EXTEND BEYOND THE DESCRIPTION OF THE FACE HEREOF. SELLER DISCLAIMS ANY IMPLIED WARRANTY OF MERCHANTABILITY OF THE GOODS OR THE FITNESS OF THE GOODS FOR ANY PURPOSE AND BUYER AGREES THAT THE GOODS ARE SOLD "AS IS."

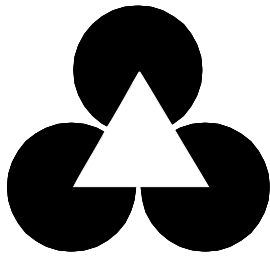

Atlas Metal
INDUSTRIES, INC.

WARRANTY INFORMATION

In order to have your invoice approved for payment by the factory, please note the following:

An authorization number must be obtained from the factory prior to performing any warranty service.

Atlas Metal will not approve excessive labor due to poor access to the unit being serviced. If design does not allow reasonable access, contact the factory.

All travel time that exceeds 100 miles round trip must be authorized by the factory.

**Thank You:
Warranty service Dept.**