

Gas Vertical Type Fryer Operating Instructions

Before you begin, please read these instructions carefully to use this product correctly, to make the product perform ideally, and to avoid hazards.

Models: ATFS-40 / ATFS-50/ ATFS-75

Dear customers and users:

Thank you for purchasing our products. In order to be able to better use this product, please read these instructions carefully before any operation, and follow the guide, to avoid any unnecessary trouble during using.

Please keep this instruction manual in a safe place for convenient reference and operation.

This instruction manual is subject to any change without further notice, and the manufacturer reserves the right of final interpretation.

The appliance is designed for commercial purposes, not for household use.

A statement instructing the purchaser to post in a prominent location instructions to be followed in the event the user smells gas. This information shall be obtained by consulting the local gas supplier.

FOR YOUR SAFETY

Do not store or use gasoline or other flammable vapors or liquids in the vicinity of this or any other appliance.

WARNING: Improper installation, adjustment, alteration, service or maintenance can cause property damage, injury or death. Read the installation, operating and maintenance instructions thoroughly before installing or servicing this equipment.

Gas Vertical Type Fryer

The Installation, Operation and Maintenance Guide

Contents

- 1. Safety Protection - 3 -
- 2. Brief Introduction - 3 -
- 3. Manufacturer's Authority and Responsibility - 3 -
- 4. Parameter Specifications - 4 -
- 5. Transport and Storage - 6 -
- 6. Installation and Debugging - 6 -
- 7. Safety Notices and Precautions - 8 -
- 8. Operating Instructions - 9 -
- 9. Cleaning and Maintenance - 10 -
- 10. Service (authorized technicians only) - 11 -
- 11. Troubleshooting - 14 -
- 12. Spare Parts - 15 -
- 13. Accessories List - 18 -

1. Safety Protection

⚠ Please make sure that the operator is an authorized and licensed technician before you allow him/her to install and operate the products. Be sure to strictly follow this instruction guide during installation and using. The manufacturer is not responsible for any danger or accidents caused by improper operation or maintenance.

⚠ Do not store flammable or explosive objects around the product. Keep all flammable and explosive objects at a safe distance away from the product for normal use.

⚠ Place the product in a reasonable position. Regarding related matters of gas, customer should execute the requirements of local gas supply sector;

⚠ If you smell a gas leak, turn off the gas valves immediately and call the gas company;

⚠ The product should not be operated by those under 18 years of age, or those with physical or mental disorders, or disabilities that lack the necessary knowledge or experience unless with appropriate instructions and sufficient safety.

2. Brief Introduction

The product is a series of gas vertical type fryer in our company production, which is novel designed, reasonable structured, convenient operated, durable used, and convenient maintained. It's equipped with a high efficiency cast-iron burner and a pilot light, and convenient to ignite the main fire burner. This is hotel, supermarket, western restaurant, noshery and food industry's ideal fryer product equipment.

3. Manufacturer's Authority and Responsibility

Banning of all or partial transformation to the products without the manufacturer's explicit authorization.

Manufacturers refused to undertake responsibility to third parties as the following reasons:

⚠ Not follow this instruction guidance and warning in using and testing;

⚠ Not in accordance with the requirements of technical parameters using this product;

⚠ Incorrectly or irrationally using the product by untrained personnel;

⚠ Not obey the local law using this product;

⚠ Be repaired or changed by unauthorized technicians;

⚠ Use the spare parts or accessories provided by non-manufacturers;

⚠ Accidents caused by force majeure;

⚠ Not strictly comply with related guide of instruction by any reason.

4. Parameter Specifications

4.1、Outline Dimensions(inch)*

ATFS-40/ATFS-50

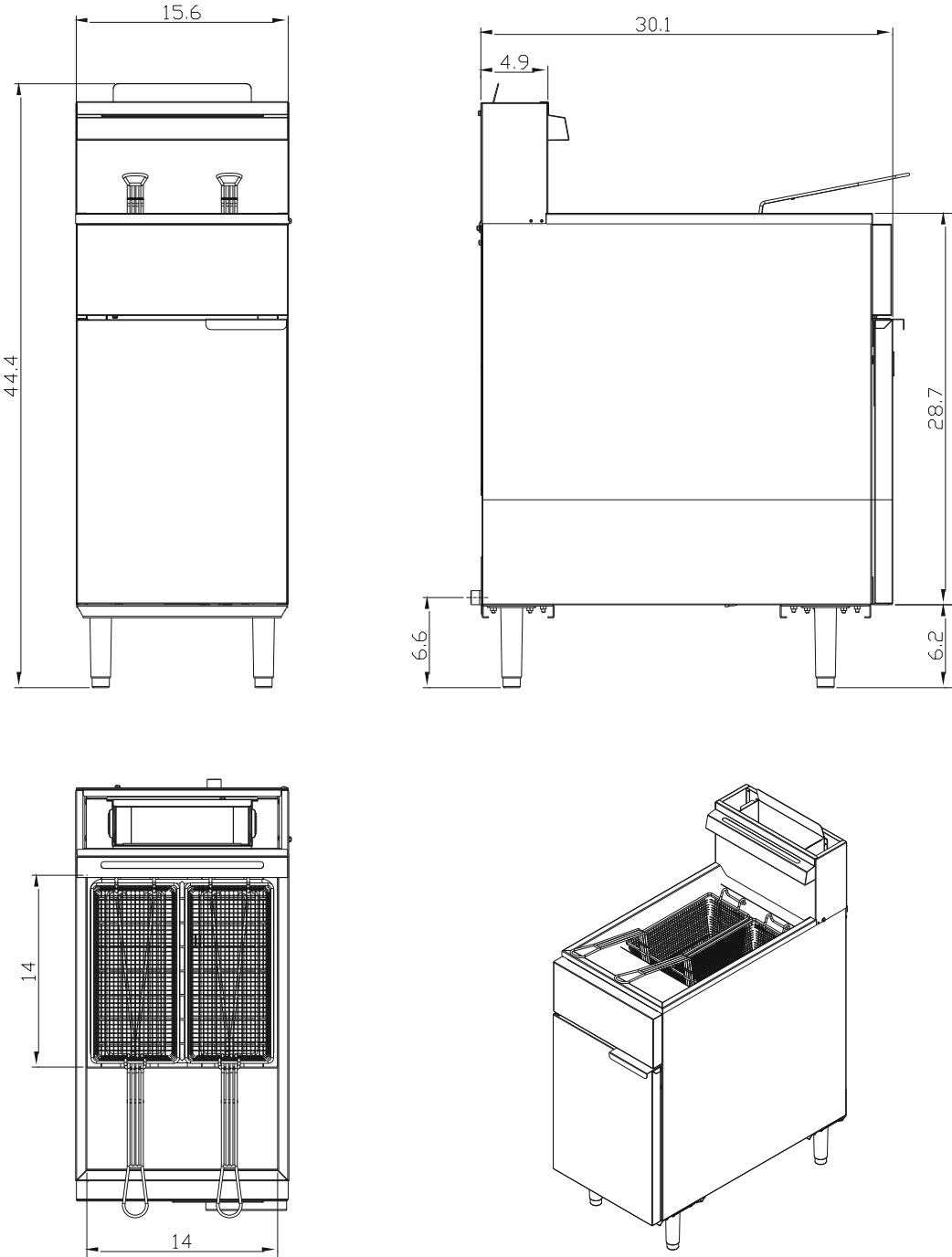

ATFS-75

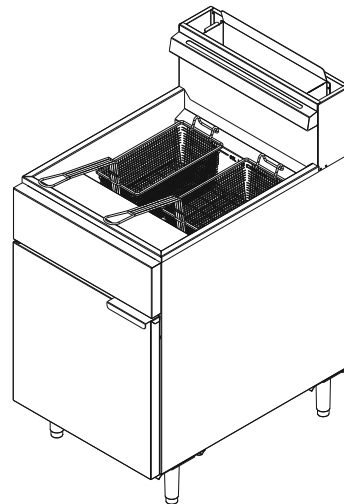
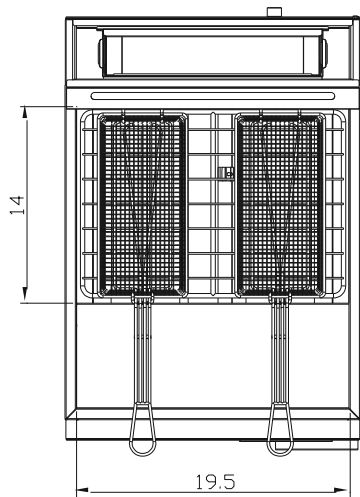
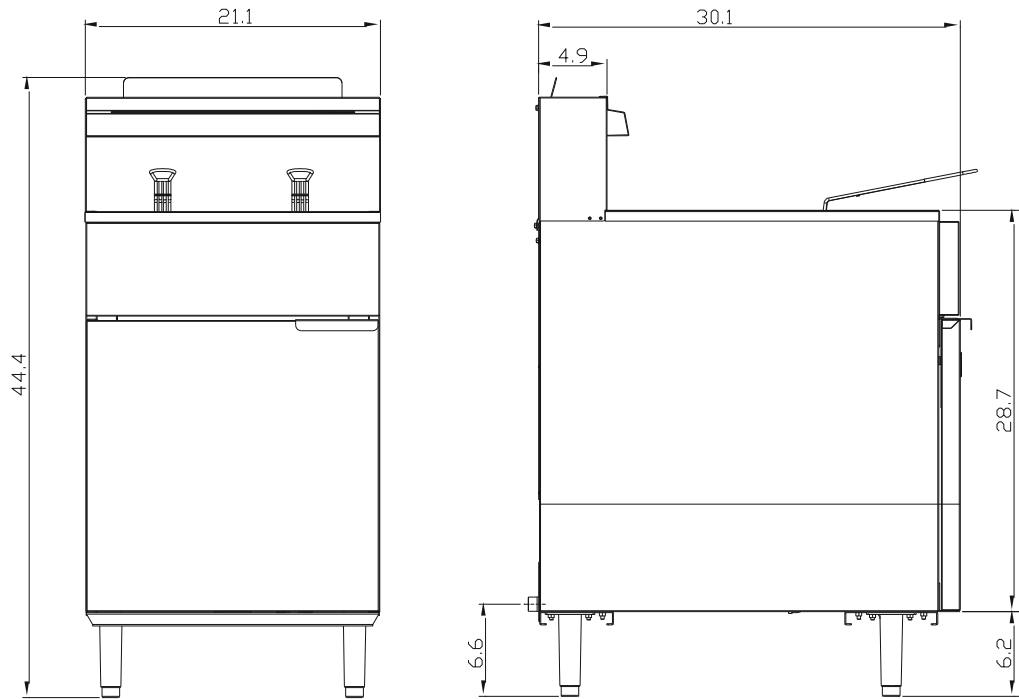

4.2. Information of Gas Supply and Burner

The minimum supplied gas pressure regulator is factory set at 4" Natural Gas W.C, and 10" L.P. Gas W.C. The external thread of product' s intake-tube is 3/4 inches.

<Table 1>

Model	#of burners and control method	Gas Species	Intake-tube pressure (in. W. C.)	Per BTU B. T. U. /h	Total BTU B. T. U. /h	Nozzle No.
ATFS-40	3 pieces Integrated control	Natural Gas	4	34,000	102,000	#36
		L. P. Gas	10	30,000	90,000	#52
ATFS-50	4 pieces Integrated control	Natural Gas	4	34,000	136,000	#36
		L. P. Gas	10	30,000	120,000	#52
ATFS-75	5 pieces Integrated control	Natural Gas	4	34,000	170,000	#36
		L. P. Gas	10	30,000	150,000	#52

5. Transport and Storage

In the process of transportation, handle carefully and keep upright to prevent damage of the product packing. Wrapped equipment should not be in open air for a long time, and shall be placed in a well-ventilated and non-corrosive gases warehouse. When equipment needs temporary storage, rainproof measures should be taken.

6. Installation and Debugging

⚠ Any erroneous installation, adjustment, refit, overhaul or maintenance may cause property damage or personal injury. The work shall be performed by authorized and licensed technicians, otherwise the manufacturer has the right not to provide warranty service;

⚠ Only be installed in accordance with the local code. If no similar standard, you should conform to the National Fuel Gas Code, ANSI Z223.1/NFPA 54, the National Gas Installation Code, CSA-B149.1, or the L. P. Gas Installation Code, CSA-B149.2 as applicable;

⚠ The appliance individual shutoff valve must be disconnected from the gas supply piping system during any pressure testing of that system at test pressures in excess of 1/2psi (3.45kPa).

6.1、Unpacking and Installation

⚠ Please dispose of all packaging materials and residues after unpacking;

⚠ Check the equipment. If it is damaged, please keep wrappers and receipts

which must be signed by the carrier representative (Driver), and contact the carriers to pursue a claim within 15 days after receiving;

- ⚠ Check all accessories complete. Refer to P18 table 4;
 - ⚠ Be sure to install supporting legs before using, and do not tear up any label or logo before normal using;
 - ⚠ Please read these instructions carefully before installation and operation. Please contact your local agent if you have any questions;
 - ⚠ The equipment shall be installed on a level, solid, non-skid and incombustible surface, and placed in a well-lighted work area with waterproof, and away from children and customers;
 - ⚠ The installation position is a well-ventilated place in accordance with the local regulations;
 - ⚠ The equipment must be installed under the matched cooking fume exhauster according to the local regulations;
 - ⚠ **Important: Installation and ventilation laws, and codes are very different, you should state and comply with all codes of the National Fire Protection Association Inc when it comes to requirements for installation of equipment;**
 - ⚠ Install legs: screw them tightly with flange face, see Fig.1;
 - ⚠ Adjustable stainless steel legs to make the equipment level, and get the same level with other series of the same stove; Please lift the equipment rather than drag if you need to move it;
 - ⚠ Slipped over internal upper smokestack, screw it with a self-tapping screw; Slipped over external upper smokestack, screw it with a self-tapping screw; Put Hanging plate in front of the external upper smokestack;
- Specific installation steps and methods read Fig.2 , Fig.3 , Fig.4;
- ⚠ Keep a distance of at least 6 inches(152mm) to equipment' s both sides and back, and keep a distance of at least 4 inches(102mm) to the bottom;
 - ⚠ Do not put anything around the equipment, and on the counter top and bottom, in order to avoid influencing combustion and air circulation;
 - ⚠ Thread glue must be resistant to the action of liquefied petroleum gases.
 - ⚠ **Warning! Use soap water or testing instrument to test whether piping joint leaks or not before using, and forbid using an open flame to test!**



Fig. 1



Fig. 2



Fig. 3



Fig. 4

6.2、 Debugging

It's very important to debug the new stove. Through the comprehensive system test of equipment, we can ensure function and safety performance of products. Discovering any potential problems before use (such as equipment's placement, ventilation, operation, etc), can avoid costly losses.

7. Safety Notices and Precautions

⚠ Warning! For your safety, do not place petrol and other flammables nearby. Please keep clean and free of flammables surroundings. (Read ANSI Z83.14B, 1991 for reference)

⚠ Warning! Any erroneous installation, adjustment and refit may cause property damage or personal injury and maintenance failure. Read the instructions carefully before installation and using.

⚠ Warning! Operation instruction must be placed in a conspicuous location. When customers smell gas in the process of using, should take safety precautions immediately. Immediately turn off the main gas valve, extinguish all heat and flames, and call 911. Safety information can be obtained from your local gas suppliers.

When using this equipment, safety precautions should always be followed, including the following:

⚠ Do not touch high-temperature smokestack plate to prevent burns when in using or just after using;

⚠ Do not cover exhaust port with anything when in using to affect the combustion effect, even cause severe accidents;

⚠ Turn off the equipment as not in using or no operator here;

⚠ Turn off the equipment as repairing, maintaining and cleaning;

⚠ If the equipment has any problems of equipment damage, gas piping leaks, igniter or valves damage, or lose product accessories, do not operate by yourself and call for the service immediately;

⚠ The use of attachments not recommended or sold by the manufacturer may cause fire, personal injury or even death;

⚠ Do not use out of doors;

⚠ The equipment is used for frying, not available for any other using;

⚠ The equipment does not contain any user-serviceable parts. Dealers or technicians will repair it. Do not take apart any spare parts without authorization;

⚠ Never change any other parts without authorization to this equipment, otherwise, may cause hazards, and the manufacturer has the right not to provide warranty service;

- ⚠ Steel cutting producers used to manufacture with sharp edges. The manufacturer has dealt with these sharp edges during production, however, we insist the operator take care when in contact with this piece of equipment;
- ⚠ Always keep hands, hair and clothing away from heating source.
- ⚠ Wait the unit cools down before cleaning. Because the unit is too hot to handle after using.

8. Operating Instructions

⚠ Before operating, make sure to place the unit horizontally by adjusting bottom adjustable legs.

8.1. Lighting the pilot light

- To ensure thermostat is “OFF” before light;
- Turn safety valve knob to “PILOT” (Fig.5), press down by force and do not loosen, then light the pilot fire(Fig.6), press and hold knob 30-45 seconds; Loosen knob if pilot fire is lighting, otherwise relight and press knob continually;
- When pilot light burns continually, turn knob to “ON” (Fig.7), without press knob.



Fig. 5



Fig. 6



Fig. 7

8.2. Igniting the main burner

- After light the pilot light, turn on the main fire valve by turning temperature control knob clockwise, ignite the main burner by the pilot light, turn temperature control knob to proper temperature according to user demand;
- ⚠ Ensure there are liquid edible oil or solid shortening in hydro-cylinder before light the main fire;

Do not over the oil level line;

⚠ Do not ignite the main fire without any oil in hydro-cylinder to damage equipment, even cause severe accidents;

8.3. Turn off the valve

- Turn temperature control knob to “OFF” , extinguish the flame of the main fire burner;
- Turn safety valve knob to “PILOT”, this is in a standby state, the pilot light is burning;

● Press down safety valve and turn to “OFF”.

8.4、Cooking

● Before using the equipment for the first time, please use a mild detergent to wipe it for cleaning. Do not use corrosive or abrasives detergent.

● Pour liquid edible oil or solid shortening into hydro-cylinder, and do not over the oil level line;

● If there is shortening, change to the lowest temperature as shortening melting to prevent burning and charring;

● Put the frying basket when the temperature reaches the preset temperature

● When you smell peculiar in the process of frying because of too high temperature or too many impurities in the oil, change or filter oil to solve it;

△ Install the matched cooking fume exhauster according to the local regulations of the char broiler;

△ Make sure to keep the air natural circulation in the kitchen.

△ **Note: Each burner nozzle has been installed before delivery, normal use without change but only switching gas.**

9. Cleaning and Maintenance

The equipment is made by high quality stainless steel raw materials, should be maintained carefully. Please clean it frequently for better performance. Cleaning frequency depends on the use intensity. Daily maintenance can improve the life of the boiler. And the climate factors must also be taken into consideration, regular cleaning can ensure the best efficiency of equipment.

● **Instructions to clean appliance regularly with recommended cleaning agents, if necessary.**

● **Clean the inner part of the hydro-cylinder, fryer basket, grid and drain oil pipe:**

1、 Pour moderate water and detergent into hydro-cylinder (do not over the highest height of the oil level line)

2、 After mix fully, turn on the main fire burner heating, turn off the main fire burner after heating about 5-10 minutes;

3、 Soak the hydro-cylinder, fryer basket and drain oil pipe in the solution for a period of time;

4、 When water temperature cools down to suitable body temperature, wipe the smudginess of the hydro-cylinder inner wall and combustion tube surface with clean clothing, meanwhile on the fryer basket, grid and drain oil pipe as the same, do not use wire brush or a hard object to wipe surface of the hydro-cylinder, wipe along the direction of metal original polishing lines;

5、 Finished wipe, turn on oil drain valve to emptying slops;

6、 Once again pour clean water into the hydro-cylinder to wash.

● **Clean the equipment surface:**

First, wipe clean the dust, grease and residue on the surface of equipment

with clean and mixed detergent clothing, second, wipe it dry with a clean clothing, do not use vinegar or corrosive liquid wiping.

- ⚠ Do not use any abrasive or flammable detergent to wipe;
- ⚠ Do not hose down, immerse or pressure wash any part of the cooker;
- ⚠ Do not use abrasive cleaning matters to wash, even not use corrosive detergent!

● Inner smokestack cleaning/maintenance: after use 3-6 months or when necessary must clean/maintenance smokestack by the manufacturer or its service agent or a similarly qualified person in order to avoid a hazard.

⚠ Warning: Before cleaning, all control valves must be turned off.

Strictly follow the lighting instructions to work again after cleaning!

⚠ Warning: Wait for the equipment to cool down after the unit has been turned off before you cleaning!

- ⚠ Cut off the gas source as not using;
- ⚠ If the equipment is not used for a long time, clean the surface by wiping it with a soft cloth and place it in a well-ventilated area;
- ⚠ Comprehensively check the equipment at least once every year by authorized and licensed technicians;
- ⚠ The product is made of 90% metals, and can not be discarded everywhere. Deal with it in accordance with the local codes.

10. Service (authorized technicians only)

All equipments have been debugged before delivery. If have the following problems, such as initial installation, gas or piping pressure issues, please refer to the relevant information on the equipment label or instructions.

● Check and adjust the main burner

There will be stable blue flame on the burning normal main burner, each endocone flame port is 3/4 inches long.

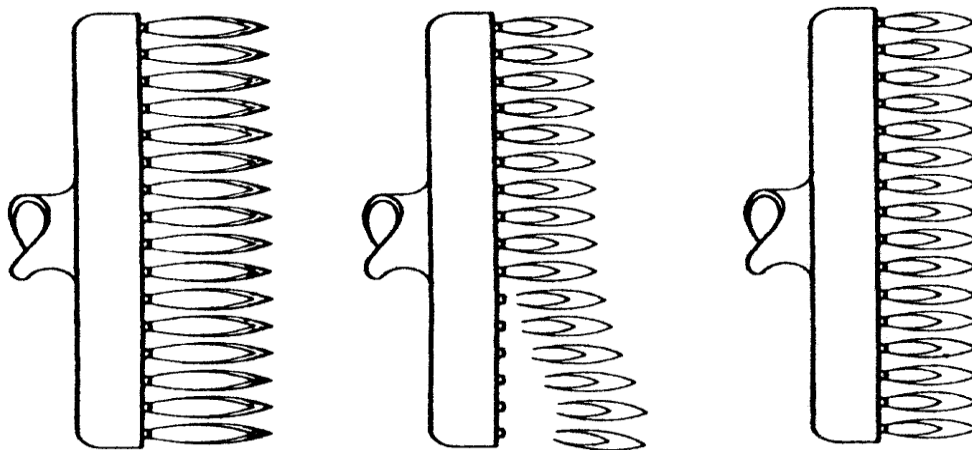

Yellow flame(lack of air) blow flame(too much air) normal flame

●Check and adjust pressure regulator

△ Supplied gas pressure regulator is factory set at 4” Natural Gas W.C, and L.P. Gas pressure is factory set at 10” Natural Gas W.C;

△ Use a pressure gauge which is equipped with liquid (such as U-type pressure gauge, the minimum value is 0.1mbar) or a digital pressure gauge to test. Steps are as following:

1、Open cabinet door, remove needle type pressure joint screw arbor (Fig.8), then slip rubber tube of pressure gauge over needle type pressure joint;

2、Start the equipment in accordance with the instructions, measuring gas supply pressure (dynamic pressure) in the work state;

3、Access to the equipment if measured data within the limits of Table 1, otherwise, you will need to adjust gas pressure regulating valve or contact gas supplier;

4、Unplug pressure gauge after you accomplish pressure testing, then install needle type pressure joint screw arbor. **Important: must screw joint arbor in order to avoid gas escaping!**

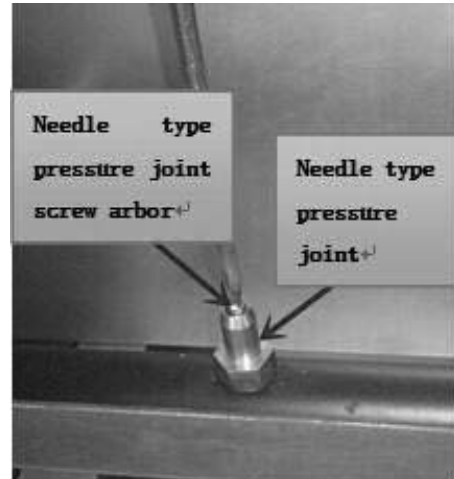

Fig.8

●Check and adjust thermostat calibration

All thermostats have been debugged before delivery, such as properly debugged a variety of detailed parameters. Debugging by authorized off-sale service technicians only.

1、Test equipment temperature with thermometer, put its thermocouple in middle of boiler.

2、Adjust control details in place, read number when temperature stabilizes.

3、If the set temperature and measurement temperature difference at 10 degrees Fahrenheit, please remeasure.

4、Delete number on the “B” , make sure reading drive is the initial state.

5、Keep B stable, adjust A by a bolt driver clockwise, dropping in temperature, or increasing temperature anticlockwise.

6、Reset dial scale, remeasure temperature, confirm temperature whether adjusted completely.

7、If modify successfully, please recover sealing screw.

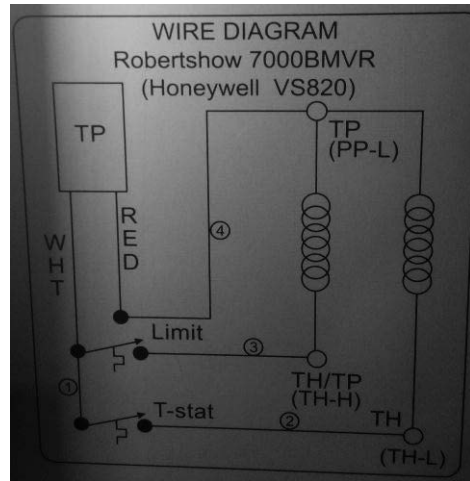
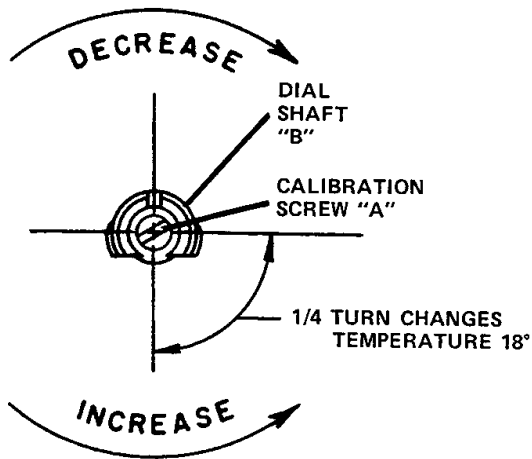

Connection Diagram

● Check and adjust automatic safety controller

The flame should surround thermoelectric couple 1/2 inches, the fire must be large enough to keep the thermocouple being red, or can not keep the safety valve open.

1. Remove controller copper adjusting cap;

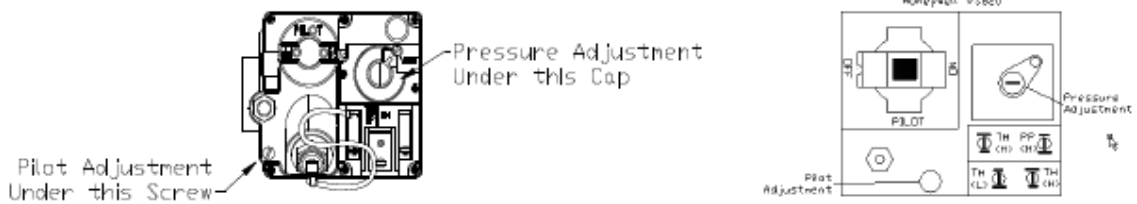

2. Adjust controller knob, ensure appropriate flame(B). A is incorrect set.

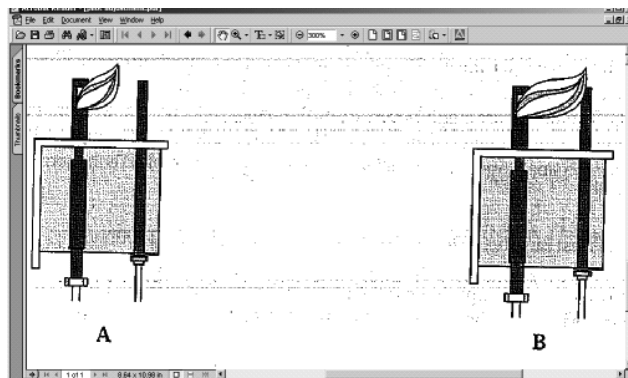

3. Reset adjusting cap.

11. Troubleshooting

<Table 2>

Problems	Possible causes	Problem solving
Not lighting	1. Insufficient gas pressure in pipe	1. Contact the local gas supply dept.
	2. Nozzle occlusion	2. Dredge nozzle
Ignite the pilot light but not the main fire	1. Insufficient gas pressure in pipe	1. Contact the local gas supply dept.
	2. The main fire nozzle occlusion	2. Dredge nozzle
	3. Gas control valves have problems	3. Change gas control valves
	4. The pilot light and the main fire's distance is too far	4. Adjust the distance of them
	5. Flame is too low	5. Adjust the height of the pilot light
Close gas and heard a sound of fire	1. Insufficient gas pressure in pipe	1. Contact the local gas supply dept.
	2. Not match nozzle aperture with gas resources	2. Adjust nozzle diameter
	3. Flow of connection pipe is not enough	3. Increase pipe's allowable flow
	4. Damper opening degree is too large	4. Adjust damper
Yellow flame and black smoke	1. Use bottom gas	1. Change gas
	2. Not match nozzle aperture with gas resources	2. Adjust nozzle diameter
	3. Not enough air to ignite	3. Increase damper opening degree
	4. In the peak of using gas, sources of gas float heavy	4. Turn down valves flow. Turn it up after the peak

The problems mentioned above are only for reference. If any fault occurs, please stop using, and contact technicians to check and repair. Safety first, turn off the power and gas supply before maintenance.

12. Spare Parts

⚠ The use of parts provided by other companies, our company has the right not to provide warranty service;

⚠ Order replacement parts from authorized representatives and after-sale service agency.

⚠ Provide the model no., serial no. and description when you order components.

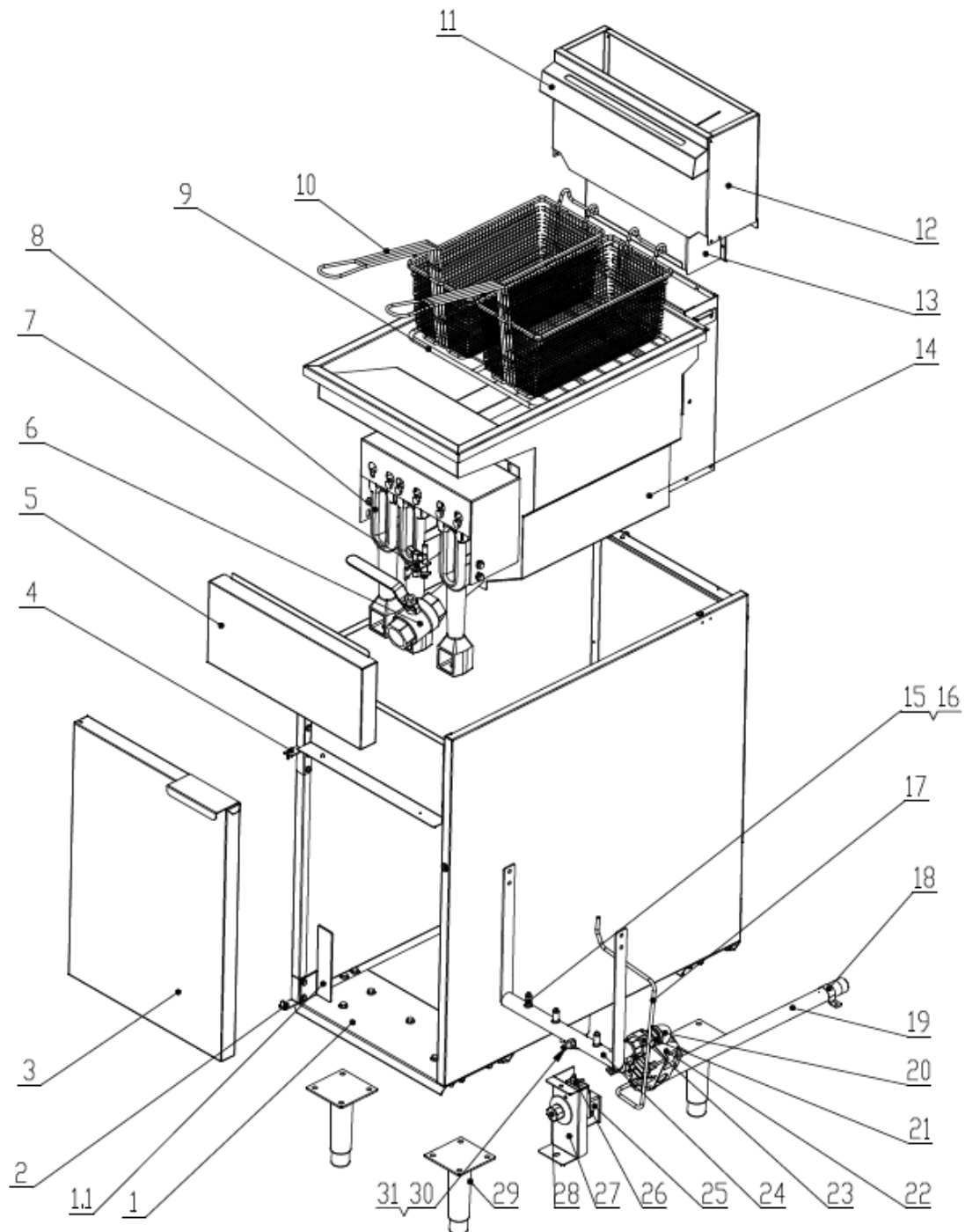

Fig. 9

〈Table 3〉

No.	Matters Code	Component name	Qty	Dimensions (mm)/Model	Remark
1	21201001001	Body assembly	1	394*746*751	ATFS-40\50
	21201003001			534*746*751	ATFS-75
1.1	21101001039	Oil drain pipe fixer	1		ATFS-40\50\75
2	301060017	Lower axillare assembly	1		ATFS-40\50\75
3	21201001007	Door assemble assembly	1	392*34*529	ATFS-40\50
	21201003007			532*34*529	ATFS-75
4	301060016	Upper axillare assembly	1		ATFS-40\50\75
5	21101001032	Front panel	1		ATFS-40\50
	21101003032				ATFS-75
6	301050011	oil drain valve	1		ATFS-40\50\75
7	301030006	Thermocouple	1	21424	ATFS-40\50\75
	301030009 (NG)	Ignition bracket (NG)		66932	
	301030010 (LP)	Ignition bracket (NG)		66705	
8	301010004	Burner	3	ATOSA-0006	ATFS-40
			4		ATFS-50
			5		ATFS-75
9	301100003	flat screen	1	342*342*φ8	ATFS-40\50
	301100004			482*342*φ8	ATFS-75
10	301100001	Fry basket	2	337*165*178	ATFS-40\50
	301100002			337*235*178	ATFS-75
11	21101001036	Hanging plate	1	392*161*1.2	ATFS-40\50
	21101003034			532*161*1.2	ATFS-75
12	21201001005	External upper smokestack assemble assembly	1	396*240*158	ATFS-40\50
	21201003005			536*240*158	ATFS-75

13	21201001006	Internal upper smokestack assemble assembly	1	278*268*98	ATFS-40
	21201002006			348*268*98	ATFS-50
	21201003006			418*268*98	ATFS-75
14	21201001002	hydro-cylinder assembly	1	397*706*438	ATFS-40
	21201002002			397*706*438	ATFS-50
	21201003002			537*706*438	ATFS-75
15	301060011	Nozzle joint	3		ATFS-40
			4		ATFS-50
			5		ATFS-75
16	301040002 (NG) 301040003 (LP)	Fryer Nozzle (NG) Fryer Nozzle (LP)	3	NG36 LP52	ATFS-40
			4		ATFS-50
			5		ATFS-75
17	301050006	Fire assembly	1	corrugated pipe / ϕ 6. 35*580	ATFS-40\50\75
18	301170012	intake-tube combination valve	1		ATFS-40\50\75
19	301070010	intake-tube	1	3/4	ATFS-40\50\75
20	301050008	Black internal and external wire elbow	2	3/4	ATFS-40\50\75
21	301050010	Two pipes joint	1	3/4	ATFS-40\50\75
22	301030003 (NG) 301030008 (LP)	Safety valve (NG) Safety valve (LP)	1	343811404A (NG) 343812458A (LP)	ATFS-40\50\75
23	301050007	loose joint	1	3/4	ATFS-40\50\75
24	301070016	Nozzle windpipe welding assembly	1		ATFS-40
	301070017				ATFS-50
	301070018				ATFS-75
25	301030005	temperature limiter	1	LCCM200300000	ATFS-40\50\75
26	301030004	thermostat	1	RX-2-24	ATFS-40\50\75
27	21101001033	temperature control mounting plate	1		ATFS-40\50\75
28	301140002	temperature control knob	1		ATFS-40\50\75

29	301110002	Adjustable steel leg	4		ATFS-40\50\75
30	301060001	Needle type pressure joint	1		ATFS-40\50\75
31	301060002	Needle type pressure joint screw arbor	1		ATFS-40\50\75

13. Accessories List

<Table 4>

Name	Model			
	Qty	ATFS-40	ATFS-50	ATFS-75
Adjustable steel leg	4 pieces	4 pieces	4 pieces	4 pieces
Frying basket	1 piece	1 piece	1 piece	1 piece
Flat screen	1 piece	1 piece	1 piece	1 piece
Oil drain pipe	1 piece	1 piece	1 piece	1 piece
External upper smokestack assembly	1 piece	1 piece	1 piece	1 piece
Internal upper smokestack assembly	1 piece	1 piece	1 piece	1 piece
U.S. six angle flange head tapping screws	2pieces	2pieces	2pieces	2pieces
U.S. six angle tapping screws	2pieces	2pieces	2pieces	2pieces
Hanging plate	1 piece	1 piece	1 piece	1 piece
Instructions	1 piece	1 piece	1 piece	1 piece



Our products have the advantages of good durability and low maintenance charge. But to update some components and necessary maintenance, can prolong life length of the products. Contact the dealer for assistance. In order to avoid confusion, please follow the format in figure 8 and table 3.