

MBF8501 ATOSA 115V

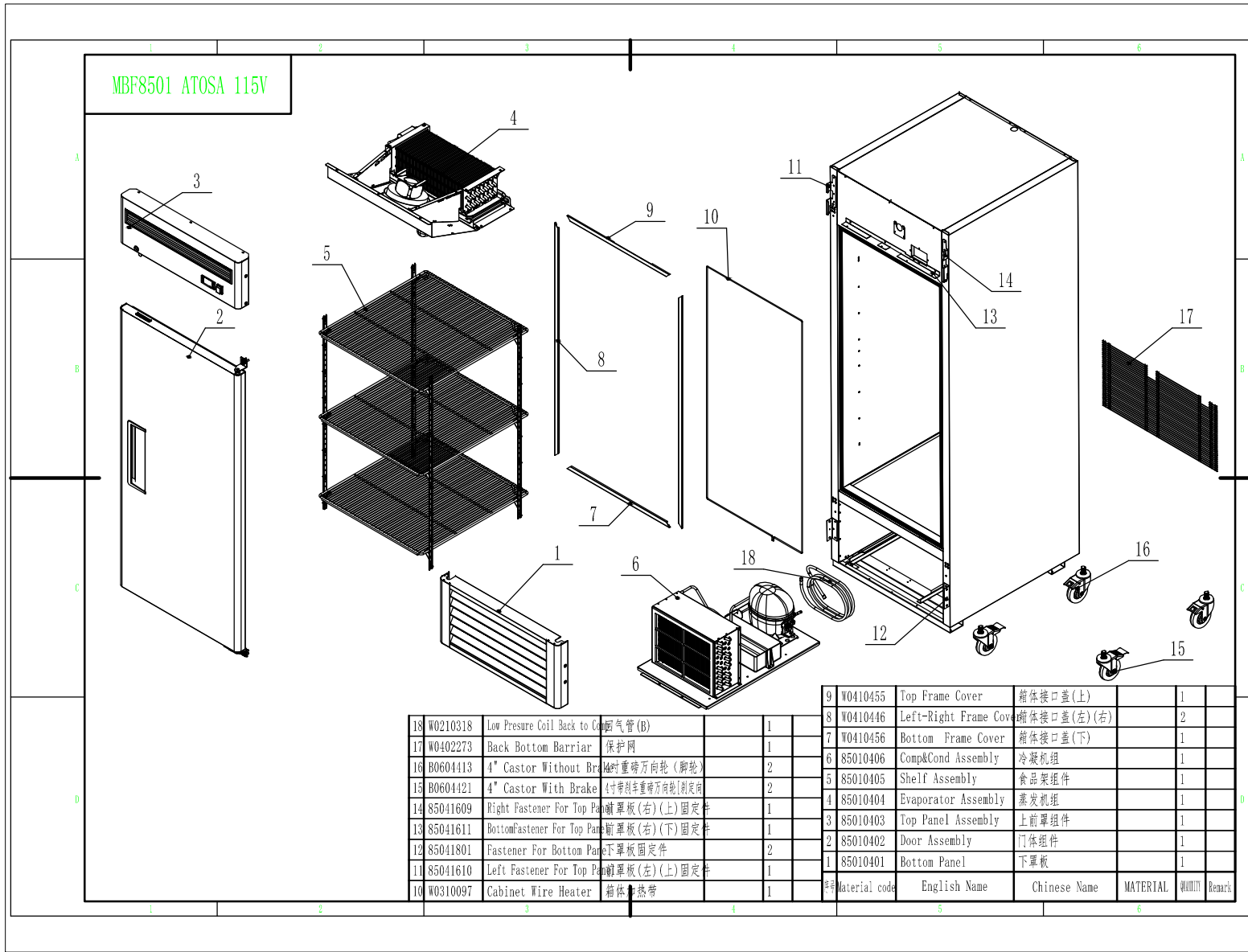

18	W0210318	Low Pressure Coil Back to Co	回气管 (B)		1
	W0402273	Back Bottom Barrier	保护网		1
	B0604413	4" Castor Without Brake	4寸重磅万向轮 (脚轮)		2
	B0604421	4" Castor With Brake	4寸带刹车重磅万向轮 (脚轮)		2
	85041609	Right Fastener For Top Panel	前罩板 (右) (上) 固定件		1
	85041611	Bottom Fastener For Top Panel	前罩板 (右) (下) 固定件		1
	85041801	Fastener For Bottom Panel	下罩板固定件		2
	85041610	Left Fastener For Top Panel	前罩板 (左) (上) 固定件		1
	W0310097	Cabinet Wire Heater	箱体电热带		1

9	W0410455	Top Frame Cover	箱体接口盖 (上)		1
8	W0410446	Left-Right Frame Cover	箱体接口盖 (左) (右)		2
7	W0410456	Bottom Frame Cover	箱体接口盖 (下)		1
6	85010406	Comp&Cond Assembly	冷凝机组		1
5	85010405	Shelf Assembly	食品架组件		1
4	85010404	Evaporator Assembly	蒸发器组		1
3	85010403	Top Panel Assembly	上罩板组件		1
2	85010402	Door Assembly	门体组件		1
1	85010401	Bottom Panel	下罩板		1
Material code	English Name	Chinese Name	MATERIAL	数量	Remark

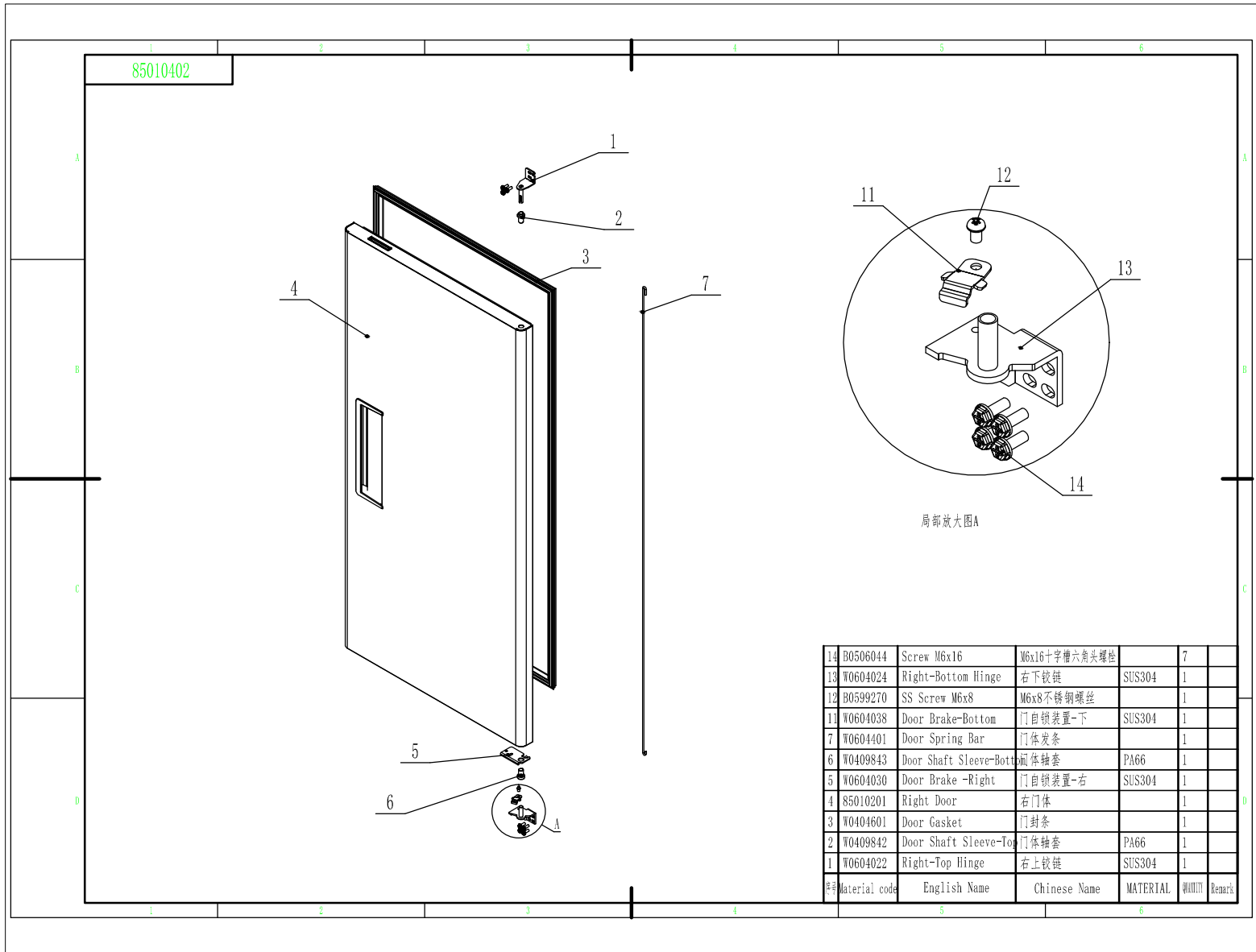

14	B0506044	Screw M6x16	M6x16十字槽六角头螺栓		7	
13	W0604024	Right-Bottom Hinge	右下铰链	SUS304	1	
12	B0599270	SS Screw M6x8	M6x8不锈钢螺丝		1	
11	W0604038	Door Brake-Bottom	门自锁装置-下	SUS304	1	
7	W0604401	Door Spring Bar	门体发条		1	
6	W0409843	Door Shaft Sleeve-Bottom	门体轴套	PA66	1	
5	W0604030	Door Brake -Right	门自锁装置-右	SUS304	1	
4	85010201	Right Door	右门体		1	
3	W0404601	Door Gasket	门封条		1	
2	W0409842	Door Shaft Sleeve-Top	门体轴套	PA66	1	
1	W0604022	Right-Top Hinge	右上铰链	SUS304	1	
材料	Material code	English Name	Chinese Name	MATERIAL	数量	Remark

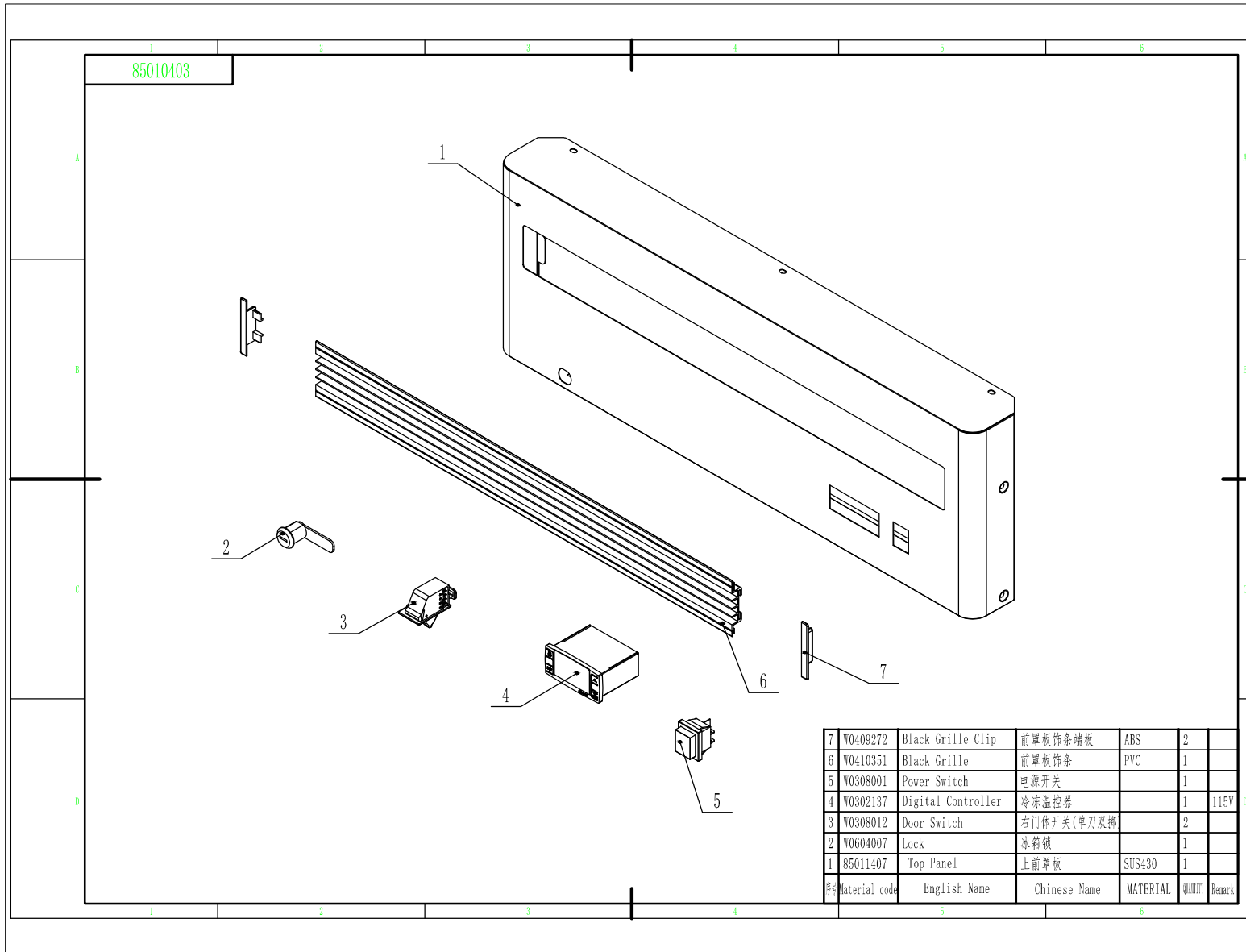

85010403

7	W0409272	Black Grille Clip	前罩板饰条端板	ABS	2	
6	W0410351	Black Grille	前罩板饰条	PVC	1	
5	W0308001	Power Switch	电源开关		1	
4	W0302137	Digital Controller	冷冻温控器		1	115V
3	W0308012	Door Switch	右门体开关(单刀双掷)		2	
2	W0604007	Lock	冰箱锁		1	
1	85011407	Top Panel	上前罩板	SUS430	1	
料号	Material code	English Name	Chinese Name	MATERIAL	数量	Remark

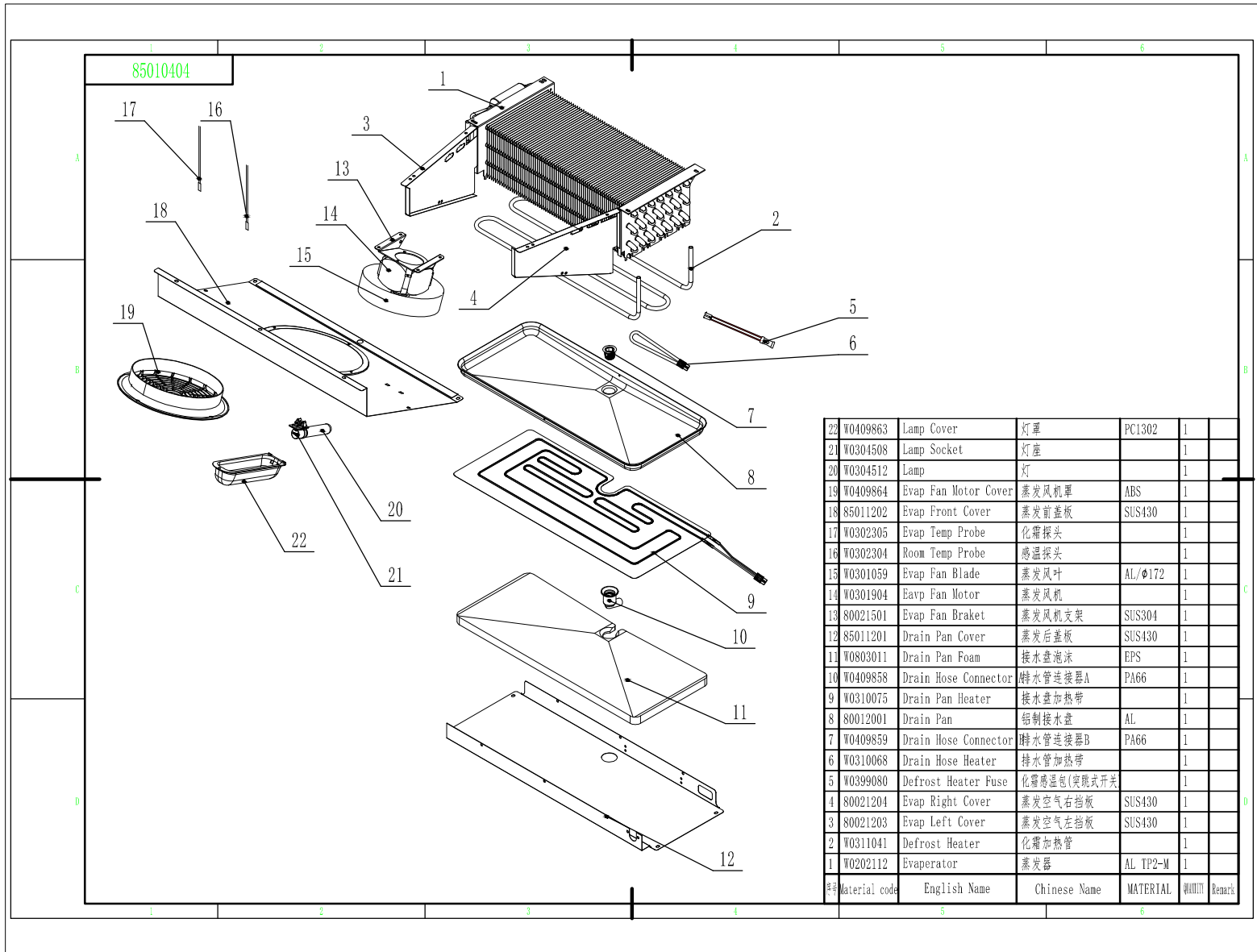

85010404

22	W0409863	Lamp Cover	灯罩	PC1302	1	
21	W0304508	Lamp Socket	灯座		1	
20	W0304512	Lamp	灯		1	
19	W0409864	Evap Fan Motor Cover	蒸发风机罩	ABS	1	
18	85011202	Evap Front Cover	蒸发前盖板	SUS430	1	
17	W0302305	Evap Temp Probe	化霜探头		1	
16	W0302304	Room Temp Probe	感温探头		1	
15	W0301059	Evap Fan Blade	蒸发风叶	AL/φ172	1	
14	W0301904	Evap Fan Motor	蒸发风机		1	
13	80021501	Evap Fan Bracket	蒸发风机支架	SUS304	1	
12	85011201	Drain Pan Cover	蒸发后盖板	SUS430	1	
11	W0803011	Drain Pan Foam	接水盘泡沫	EPS	1	
10	W0409858	Drain Hose Connector	排水管连接器A	PA66	1	
9	W0310075	Drain Pan Heater	接水盘加热带		1	
8	80012001	Drain Pan	铝制接水盘	AL	1	
7	W0409859	Drain Hose Connector	排水管连接器B	PA66	1	
6	W0310068	Drain Hose Heater	排水管加热带		1	
5	W0399080	Defrost Heater Fuse	化霜感温包(突跳式开关)		1	
4	80021204	Evap Right Cover	蒸发空气右挡板	SUS430	1	
3	80021203	Evap Left Cover	蒸发空气左挡板	SUS430	1	
2	W0311041	Defrost Heater	化霜加热管		1	
1	W0202112	Evaporator	蒸发器	AL TP2-M	1	
料号	Material code	English Name	Chinese Name	MATERIAL	数量	Remark

85010405

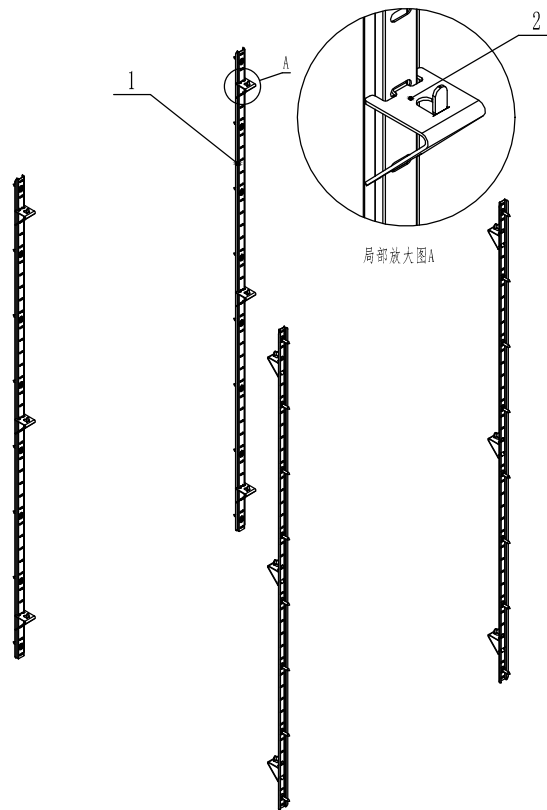
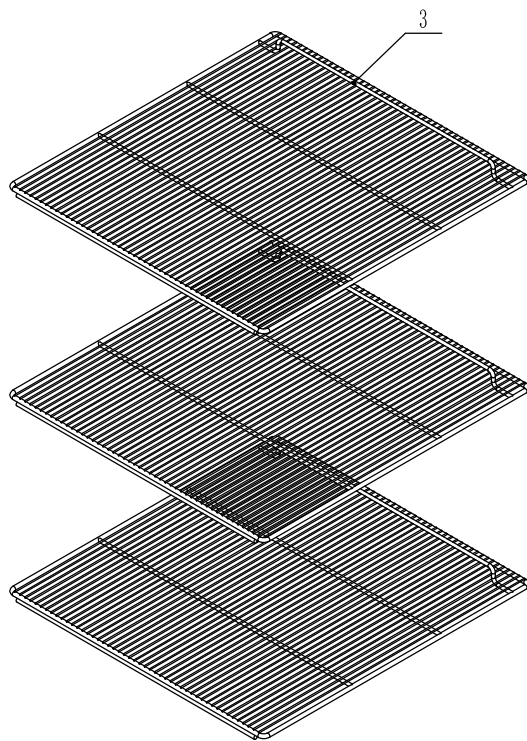

3	W0402195	Shelf	食品架		3	
2	00542013	Shelf Clip	食品架搁脚	SUS430	12	
1	80037410	Pilaster For Shelf	食品架隔条	SUS430	4	
料号	Material code	English Name	Chinese Name	MATERIAL	数量	Remark

85010406

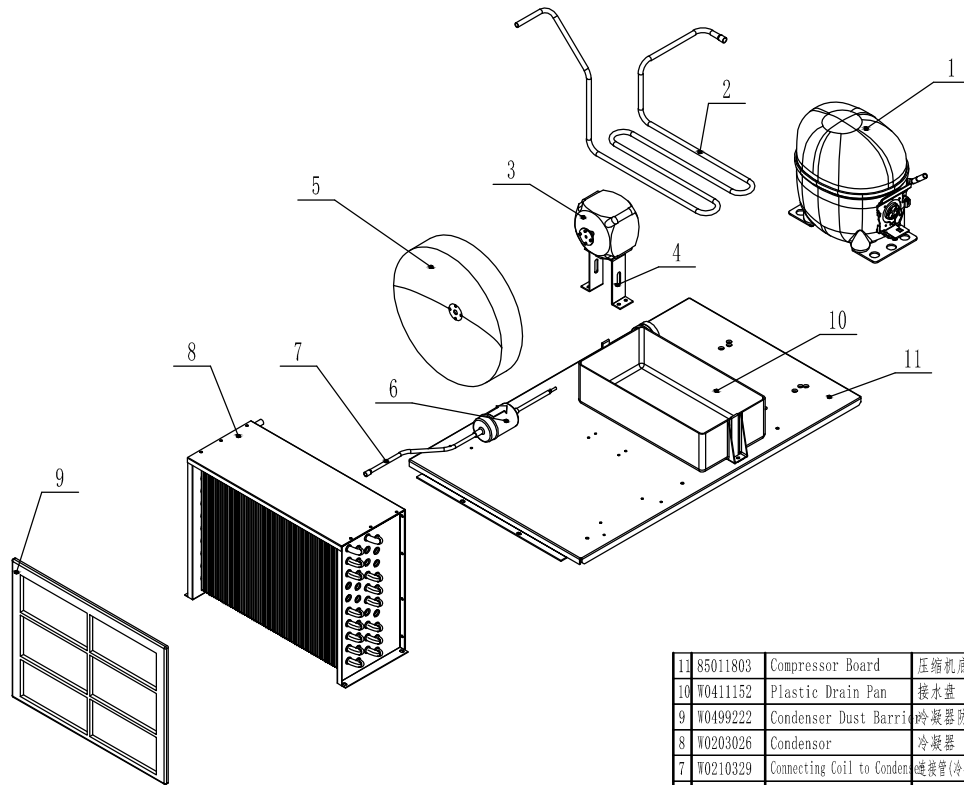

11	85011803	Compressor Board	压缩机底板	GI	1	
10	W0411152	Plastic Drain Pan	接水盘	ABS	1	
9	W0499222	Condenser Dust Barrier	冷凝器防尘罩		1	
8	W0203026	Condensor	冷凝器	GI TP2-M	1	
7	W0210329	Connecting Coil to Condens	连接管(冷凝器-干燥过滤器)	TP2-M	1	
6	W0204003	Dry Filter	干燥过滤器		1	
5	W0301056	Condenser Fan Blade	冷凝风机叶	AL/φ250	1	
4	80031601	Condenser Fan Braket	冷凝风机支架	GI	1	
3	W0301905	Condensor Fan	冷凝风机		1	
2	W0210330	High Presure Coil	散热管	TP2-M	1	
1	W0201820	Compressor	压缩机		1	
	Material code	English Name	Chinese Name	MATERIAL	数量	Remark