

Automatic Lift Fryer

MODELS ALF-F, & ALF-FC

Service Manual

Serial Numbers 126627 and higher



BKI LIMITED WARRANTY
2812 Grandview Dr. • Simpsonville, SC 29680 • USA
(864) 963-3471 • Toll Free: (800) 927-6887 • Fax: (864) 963-5316

WHAT IS COVERED	<p>This warranty covers defects in material and workmanship under normal use, and applies only to the original purchaser providing that:</p> <ul style="list-style-type: none"><input type="checkbox"/> The equipment has not been accidentally or intentionally damaged, altered or misused;<input type="checkbox"/> The equipment is properly installed, adjusted, operated and maintained in accordance with national and local codes, and in accordance with the installation and operating instructions provided with this product.<input type="checkbox"/> The serial number rating plate affixed to the equipment has not been defaced or removed.
WHO IS COVERED	<p>This warranty is extended to the original purchaser and applies only to equipment purchased for use in the U.S.A.</p>
COVERAGE PERIOD	<ul style="list-style-type: none"><input type="checkbox"/> Warranty claims must be received in writing by BKI within one (1) year from date of installation or within one (1) year and three (3) months from data of shipment from the factory, whichever comes first.<input type="checkbox"/> COB Models: One (1) Year limited parts and labor.<input type="checkbox"/> COM Models: Two (2) Year limited parts and labor. COM convection ovens also have a two (2) year door warranty.<input type="checkbox"/> CO1 Models: Two (2) Year limited parts and labor. Five (5) Year limited door warranty.<input type="checkbox"/> BevLes Products: Two (2) Year limited parts and labor.<input type="checkbox"/> Warranty period begins the date of dealer invoice to customer or ninety (90) days after shipment date from BKI, whichever comes first.
WARRANTY COVERAGE	<p>This warranty covers on-site labor, parts and reasonable travel time and travel expenses of the authorized service representative up to (100) miles round trip and (2) hours travel time and performed during regular, weekday business hours.</p>
EXCEPTIONS	<p>Any exceptions must be pre-approved in advance and in writing by BKI. The extended door warranty on convection ovens years 3 through 5 is a parts only warranty and does not include labor, travel, mileage or any other charges.</p>
EXCLUSIONS	<ul style="list-style-type: none"><input type="checkbox"/> Negligence or acts of God,<input type="checkbox"/> Thermostat calibrations after (30) days from equipment installation date,<input type="checkbox"/> Air and gas adjustments,<input type="checkbox"/> Light bulbs,<input type="checkbox"/> Glass doors and door adjustments,<input type="checkbox"/> Fuses,<input type="checkbox"/> Adjustments to burner flames and cleaning of pilot burners,<input type="checkbox"/> Tightening of screws or fasteners,<input type="checkbox"/> Failures caused by erratic voltages or gas suppliers,<input type="checkbox"/> Unauthorized repair by anyone other than a BKI Factory Authorized Service Center,<input type="checkbox"/> Damage in shipment,<input type="checkbox"/> Alteration, misuse or improper installation,<input type="checkbox"/> Thermostats and safety valves with broken capillary tubes,<input type="checkbox"/> Freight - other than normal UPS charges,<input type="checkbox"/> Ordinary wear and tear,<input type="checkbox"/> Failure to follow installation and/or operating instructions,<input type="checkbox"/> Events beyond control of the company.
INSTALLATION	<p>Leveling, as well as proper installation and check out of all new equipment - per appropriate installation and use materials – is the responsibility of the dealer or installer, not the manufacturer.</p>
REPLACEMENT PARTS	<p>BKI genuine Factory OEM parts receive a (90) day materials warranty effective from the date of installation by a BKI Factory Authorized Service Center.</p> <p>Warranty is in lieu of all other warranties, expressed or implied, and all other obligations or liabilities on the manufacturer's part. BKI shall in no event be liable for any special, indirect or consequential damages, or in any event for damages in excess of the purchase price of the unit. The repair or replacement of proven defective parts shall constitute a fulfillment of all obligations under the terms of this warranty.</p>

Table of Contents

Table of Contents	1
Introduction	2
Safety Precautions	2
Safety Signs and Messages	2
Safe Work Practices	3
Safety Labels	7
Installation	8
Unpacking and Handling	8
Assembly and Mounting	8
Wiring	8
Initial Test and Adjustment	9
Replacement Parts	10
Assemblies	10
Components	21
Accessories	23
Wiring Diagrams	25

Introduction

The ALF Fryer is compact, attractive and functional in design. It is constructed of a stainless steel fryer pot for cleaning ease. Exclusive BKI patented features and safety devices offer flexibility, efficiency and reliability plus **PERFECTION IN FRYING!**

The BKI name and trademark on this unit assures you of the finest in design and engineering -- that it has been built with care and dedication -- using the best materials available. Attention to the operating instructions regarding proper installation, operation, and maintenance will result in long lasting dependability to insure the highest profitable return on your investment.

NOTICE

PLEASE READ THIS ENTIRE MANUAL BEFORE OPERATING THE UNIT. If you have any questions, please contact your BKI Distributor. If they are unable to answer your questions, contact the BKI Technical Service Department, toll free: 1-800-927-6887. Outside the U.S., call 1-864-963-3471.

Safety Precautions

Always follow recommended safety precautions listed in this manual. Below is the safety alert symbol. When you see this symbol on your equipment, be alert to the potential for personal injury or property damage.



Safety Signs and Messages

The following Safety signs and messages are placed in this manual to provide instructions and identify specific areas where potential hazards exist and special precautions should be taken. Know and understand the meaning of these instructions, signs, and messages. Damage to the equipment, death or serious injury to you or other persons may result if these messages are not followed.

▲ DANGER

This message indicates an imminently hazardous situation which, if not avoided, will result in death or serious injury.

▲ WARNING

This message indicates a potentially hazardous situation, which, if not avoided, could result in death or serious injury.

▲ CAUTION

This message indicates a potentially hazardous situation, which, if not avoided, may result in minor or moderate injury. It may also be used to alert against unsafe practices.

NOTICE

This message is used when special information, instructions or identification are required relating to procedures, equipment, tools, capacities and other special data.

Safe Work Practices



Noncombustible Floors Only

Make sure your floor is noncombustible. Do not operate your fryer on floors that are wood, carpeted or have rubber mats.

- Placing your fryer on a combustible floor could cause a fire. Serious injury could result.
- Examples of noncombustible floors where you can safely place your fryer are concrete, tile, and ceramic.



Keep The Area Around Your Fryer Uncluttered

Make sure to keep the area around your fryer clear of any obstacles.

Serious injury can occur if you trip or fall near the fryer. You could be burned by hot shortening that splashes out of the fryer or by falling against the hot metal of the fryer.



Keep The Floor Around Your Fryer Clean Of Shortening

Make sure to keep the floor around your fryer clean of shortening and other liquids.

Serious injury can occur if you slip near your fryer. You could be burned by hot shortening that splashes out of the fryer or by falling against the hot metal of the fryer.

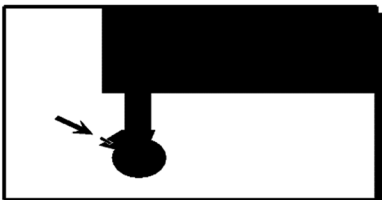

Keep The Casters Locked

To avoid spilling shortening, keep the casters locked. If any shortening spills near your fryer, clean it up immediately.

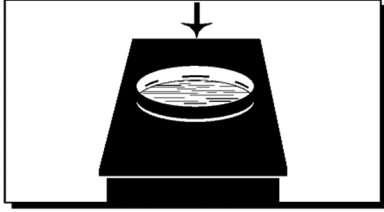

Do Not Overfill The Fryer With Shortening

Hot shortening and steam may escape and burn you if you put too much shortening in the fryer. Fill the fryer to approximately one inch below the fill marks that are inside the fryer pot. Heat the shortening. If needed, carefully add more shortening to bring the level to the fill marks.



Do Not Let Any Water Get Into The Fryer

Always remove excess moisture from food before placing it into the fryer basket. Water will cause the hot shortening to spatter. You could be burned.



Do Not Overload The Basket With Food

Hot shortening and steam may escape and burn you if you place too much food in the basket.

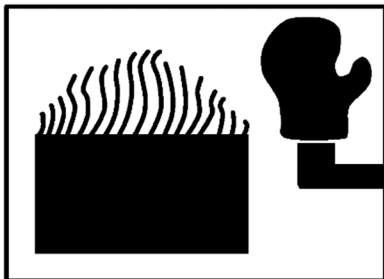

Wear Safe Clothing Appropriate To Your Job

Always wear your insulated mitts when handling the fryer basket or touch any hot metal surfaces. You received a pair of insulated mitts with your fryer. If you lose or damage your mitts, you can buy new ones at your local restaurant equipment supply store or from your local **BKI** Distributor.

Always wear non-skid shoes when working around the fryer or any other equipment that uses shortening. Never wear loose clothing such as neckties or scarves while operating your fryer. Keep loose hair tied back or in a hair net while operating your fryer.

Always wear appropriate personal protection equipment during the filtering process to guard against possible injury from hot oil.

Always wear appropriate personal protection equipment during the boil-out process to guard against possible injury from hot cleaning solution.

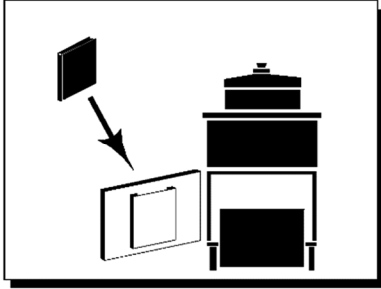

Keep this manual with the Equipment

This manual is an important part of your equipment. Always keep it near for easy access.

If you need to replace this manual, contact:

BKI

Technical Services Department
2812 Grandview Dr., Simpsonville, S.C. 29680
Or call toll free: 1-800-927-6887
Outside the U.S., call 864-963-3471



Protect Children

Keep children away from this equipment. Children may not understand that this equipment is dangerous for them and others.

NEVER allow children to play near or operate your equipment.



Keep Safety Labels Clean and in Good Condition

Do not remove or cover any safety labels on your equipment. Keep all safety labels clean and in good condition. Replace any damaged or missing safety labels. Refer to the Safety Labels section for illustration and location of safety labels on this unit.

If you need a new safety label, obtain the number of the specific label illustrated on page 7, then contact:

BKI

Technical Services Department
2812 Grandview Dr., Simpsonville, S.C. 29680
Or call toll free: 1-800-927-6887
Outside the U.S., call 864-963-3471

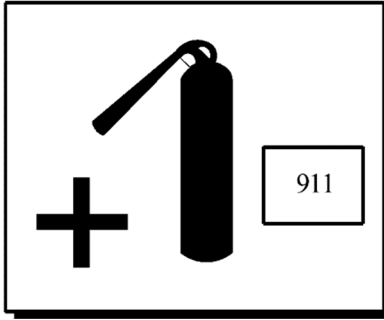

Be Prepared for Emergencies

Be prepared for fires, injuries, or other emergencies.

Keep a first aid kit and a fire extinguisher near the equipment. You must use a 40-pound Type BC fire extinguisher and keep it within 25 feet of your equipment.

Keep emergency numbers for doctors, ambulance services, hospitals, and the fire department near your telephone.

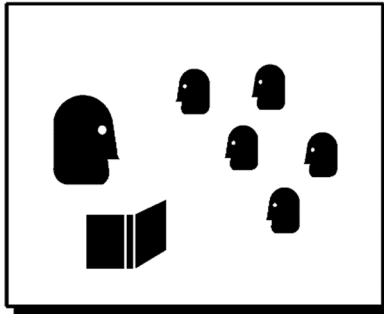

Know your responsibilities as an Employer

- Make certain your employees know how to operate the equipment.
- Make certain your employees are aware of the safety precautions on the equipment and in this manual.
- Make certain that you have thoroughly trained your employees about operating the equipment safely.
- Make certain the equipment is in proper working condition. If you make unauthorized modifications to the equipment, you will reduce the function and safety of the equipment.

Safety Labels

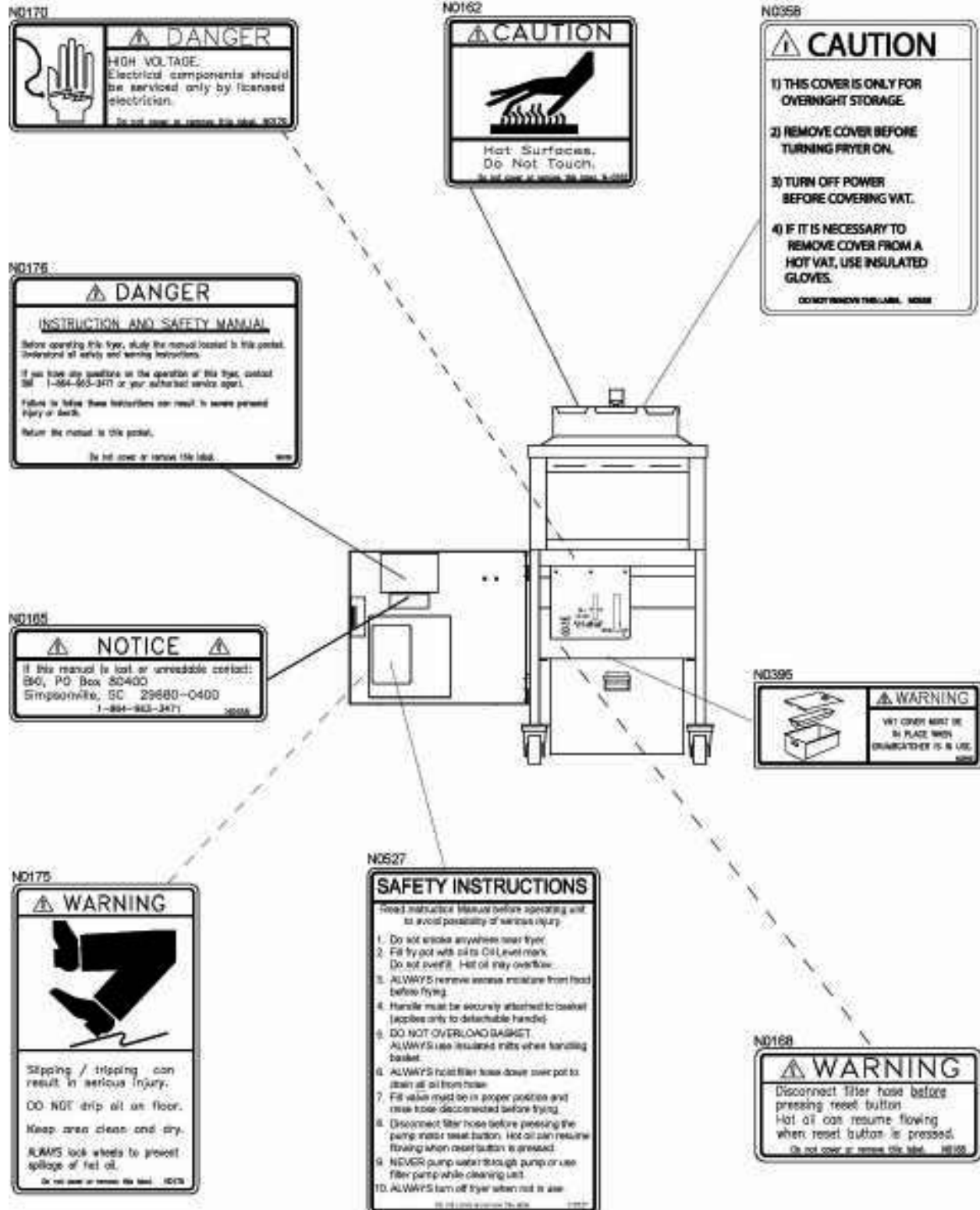

Installation

⚠ WARNING

Serious injury, equipment damage or death could result if attempting to install this fryer yourself. Ensure that an authorized BKI service agent installs the fryer.

Unpacking and Handling

It is the owners' responsibility to file all freight claims with the delivering truck line. Inspect all cartons and crates for damage as soon as they arrive. If damage to cartons or crates is found, or if a shortage is found, note this on the bill of lading (all copies) prior to signing.

If damage is found when the equipment is opened, immediately call the delivering truck line and follow up the call with a written report indicating concealed damage to your shipment. Ask for an immediate inspection of your concealed damage item. Packaging material **MUST** be retained to show the inspector from the truck line.

Assembly and Mounting

1. Remove all packing materials from the interior and exterior of the fryer.

⚠ WARNING

Risk of electric shock – Fryer must be secured to building structure. Follow restraining device instructions for proper installation.

2. Install an ANSI Z83.11/CGA 1.8 compliant restraining device (such as BKI part number FT0279) per the instructions below:
 - Mount the wall attachment according the restraining device manufacturer instructions.
 - Attach the spring-loaded hook on the restraining device to the eye-bolt mounted to the fryer then attach the other spring-loaded hook to the wall attachment.
3. Lock the casters so the fryer does not move. Every time the fryer is used, make sure the casters are locked so the fryer cannot move.
4. Clean the fryer pot before filling with shortening.
5. Place the DRAIN handle in the CLOSED position.

Wiring

⚠ WARNING

Electrocution, equipment failure or property damage could result if an unlicensed electrician performs the electrical installation. Ensure that a licensed electrician perform the electrical installation in accordance with local codes, or in the absence of local codes, with the National Electrical Code, ANSI NFPA 70-20XX.

This unit, when installed by an authorized BKI service agent, must be wired for use in accordance with all applicable local, state, and federal codes. For specific electrical requirements and connections refer to the wiring diagram attached to the unit or provided in the Service Manual.

Initial Test and Adjustment

1. Fill pot with shortening to about one inch below the mark.

NOTICE

Use only high-quality shortening that has low moisture content, a high smoke point and no additives.

CAUTION

Overfilling the fryer pot with shortening could lead to serious injury. Ensure that the fryer pot is filled with shortening only to the fill mark when shortening is hot. Do not use any shortening other than what is specified in this manual and do not overfill the fryer pot.



2. Place the **FILTER/OFF/FRY** switch to the **FRY** position. The shortening should begin to heat and begin to reach the fill mark inside the pot. Add more shortening as required to reach the fill mark. Refer to the troubleshooting section if this does not occur.

Replacement Parts

Use the information in this section to identify replacement parts. To order replacement parts, call your local BKI sales and service representative. Before calling, please note the serial number, model number and voltage on the rating tag affixed to the unit.

Assemblies

Description	Assembly #	Figure #	Table #
DRAIN VALVE & PLUGS	SB1999S	Figure 1	Table 1
DOOR ASSEMBLY	SB1289	Figure 2	Table 2
DRAIN/MOTOR/PIPING ASSEMBLY	N/A	Figure 3	Table 3
CONTROL PANEL ALF-F (1/3 Phase) CONTROL PANEL ALF-F (3 Phase)	AN15210700 AN15210600	Figure 4	Table 4
CONTROL PANEL ALF-FC (1/3 Phase) CONTROL PANEL ALF-FC (3 Phase)	AN15210900 AN15210800	Figure 5	Table 5
OIL VAT ASSEMBLY	AN86202800	Figure 6	Table 6
QUICK DISCONNECT ASSEMBLY	AB86200700 SB1997S	Figure 7	Table 7

Figure 1. Drain Valve & Plugs (SB1999S)

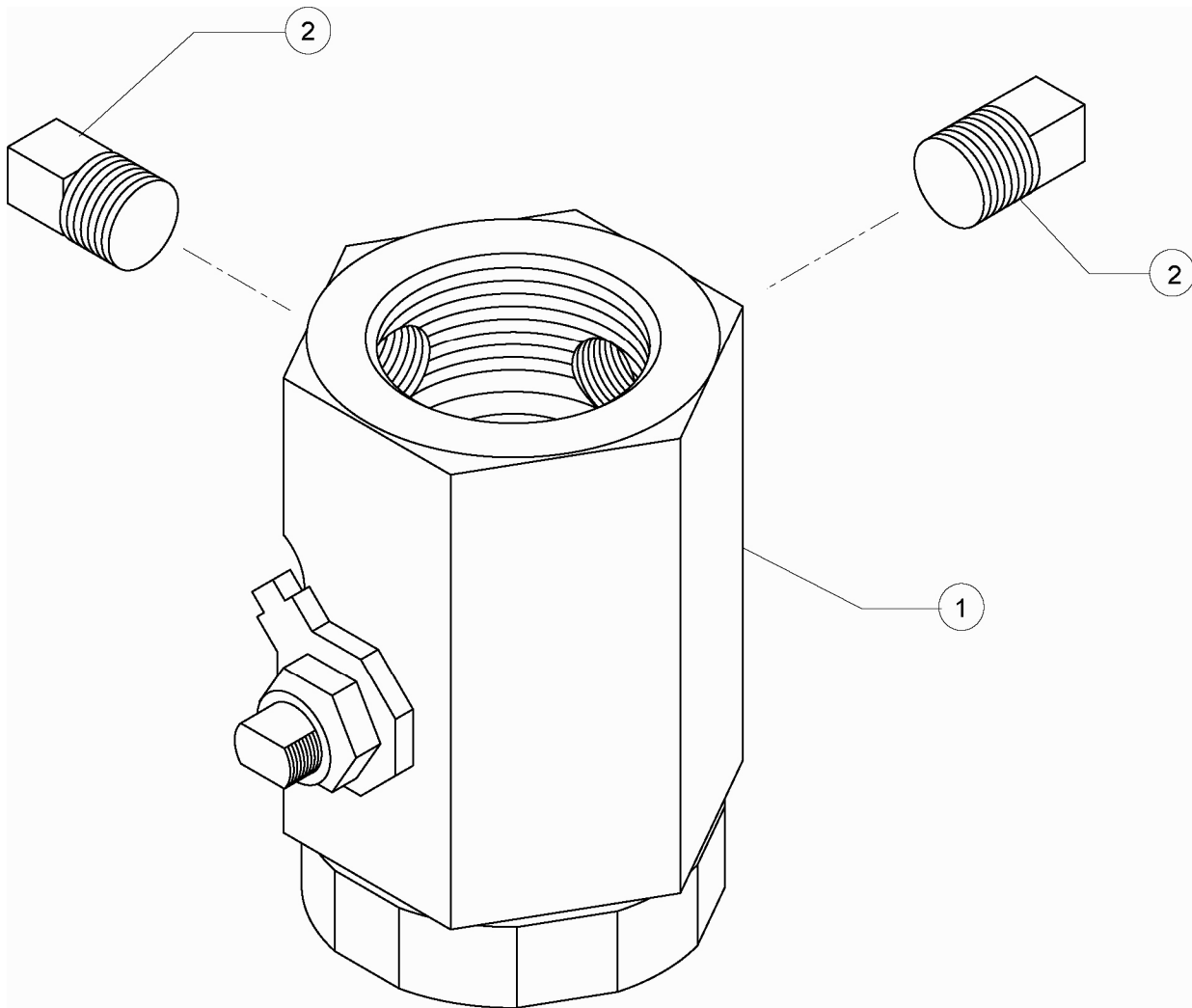

Table 1. Drain Valve & Plugs (SB1999S) Parts

ITEM #	PART #	QTY	DESCRIPTION
1	MB19101000	1	DRAIN VALVE REPLACEMENT
2	FT0243	2	PLUG, 3/8" SQ HEAD PIPE

Figure 2. Door Assembly (SB1289)

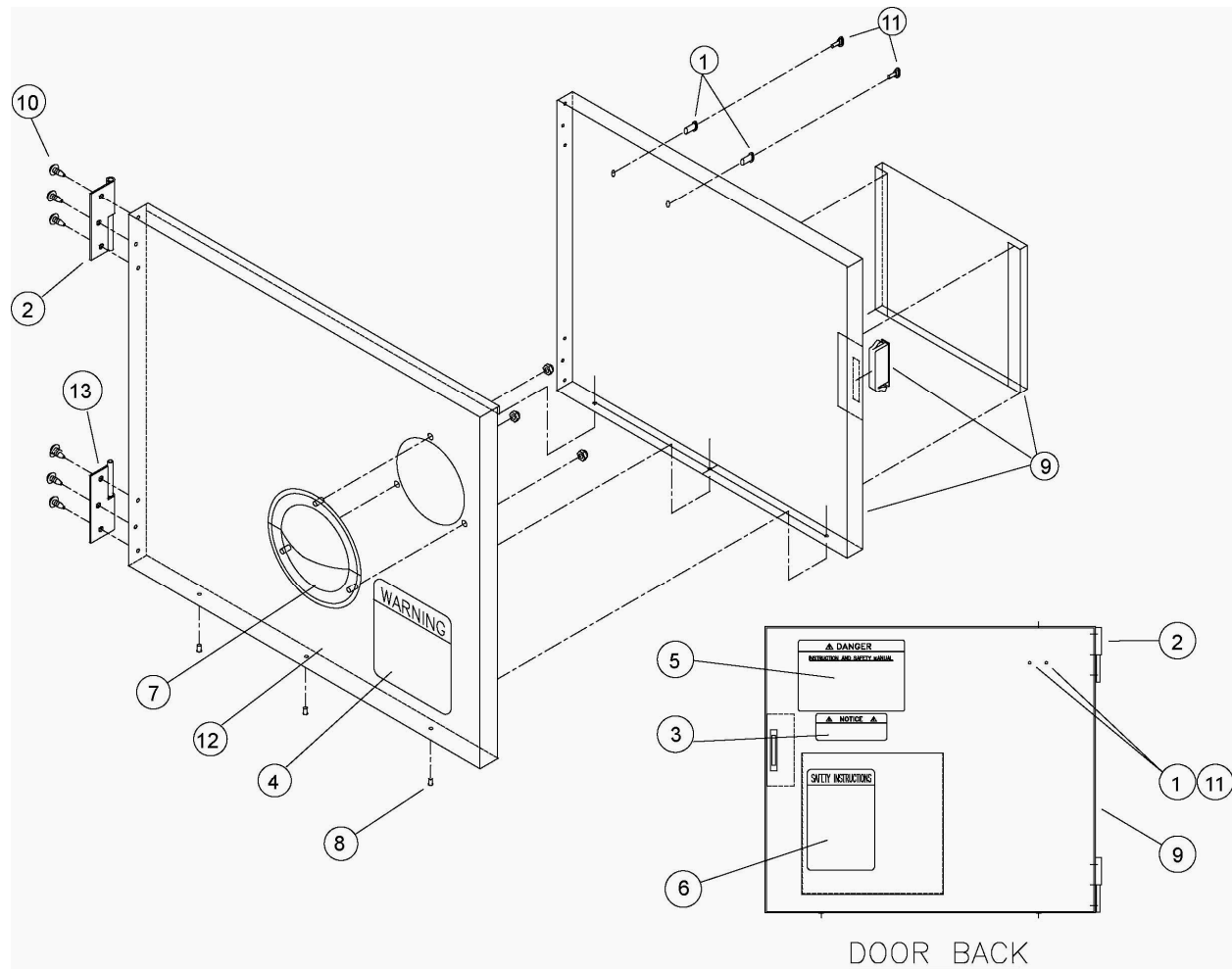

Table 2. Door Assembly (SB1289) Parts

ITEM #	PART #	QTY	DESCRIPTION
1	F0083	2	THREAD INSERT 10-24 STEEL
2	H0010	1	HINGE, LH PIN HALF
3	N0165	1	DECAL, NOTICE LOST MANUAL
4	N0175	1	DECAL, SLIPPING ADMONITIONS
5	N0176	1	DECAL, INSTR & SAFETY MANUAL
6	N0527	1	DECAL, SAFETY INSTR FRYERS
7	P0022	1	HANDLE, PULL SS P60-1010
8	RIV172	3	RIVET, 1/8 X 1/4 CS PLT POP
9	SB1290	1	DOOR MAGNET WELD, ALF
10	SCR008	6	SCREW, 10 X 1/2 PHIL TRUSS HD
11	SCR075	2	SCREW, 10-24 X 3/8 SHOULDER
12	WLPFA096	1	DOOR, LPF CORNERS WELDED
13	H0009	1	HINGE, RH PIN HALF

Figure 3. Drain/Motor/Piping Assembly

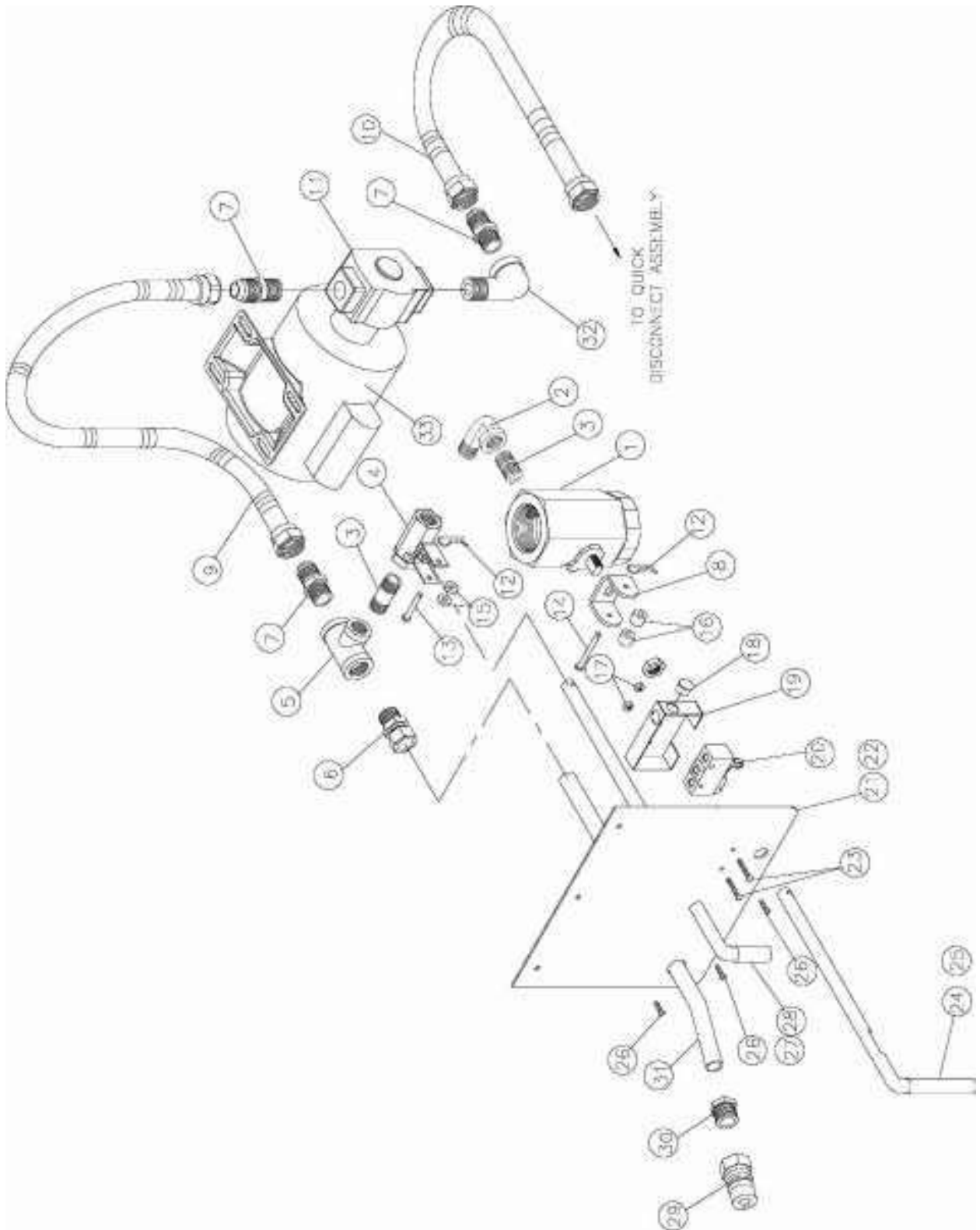
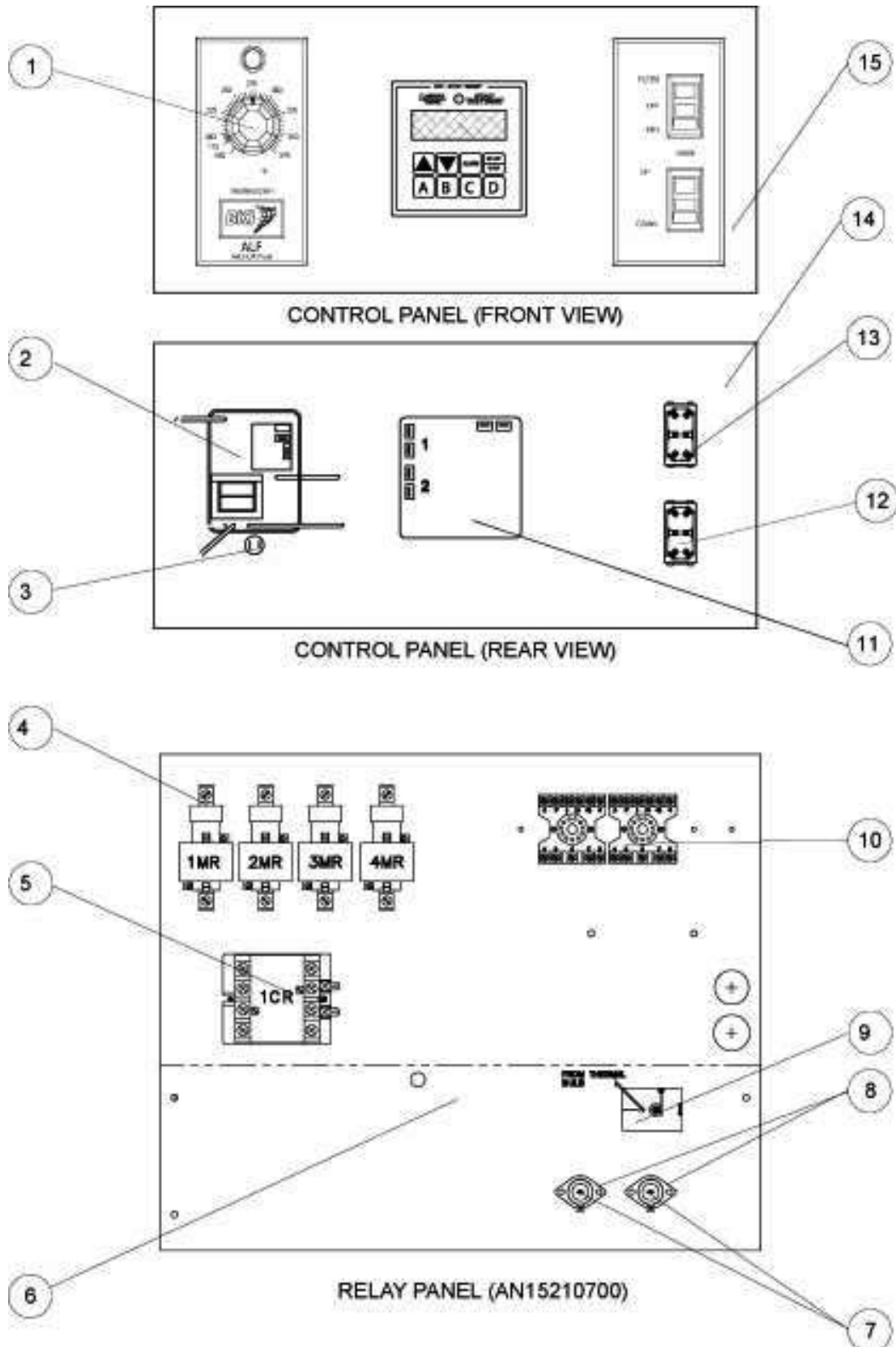

Table 3. Drain/Motor/Piping Assembly Parts

ITEM #	PART #	QTY	DESCRIPTION
1	D0060	1	VALVE, DRAIN SS BALL&PLT.CAR.STEM
2	FT0044	1	ELL, STREET 3/8 90 DEG BLACK
3	FT0412	2	NIPPLE, 3/8 NPT X 1 1/2 SCH 40
4	SB1314	1	BALL VALVE ASSY, FRYERS
5	FT0538	1	TEE, 1/2 X 1/2 X 3/8 BLK
6	FT0507	1	CONNECTOR, MALE 10FBU-S NKL PLTD
7	FT0536	3	COUPLING, 5/8 45° FLARE TO
8	FT0543	1	DRAIN VALVE BRACKET, FRYERS
9	TU0206	1	TUBING, 29" 1/2" ID
10	TU0205	1	TUBING, 12" 1/2" ID
11	P0070	1	PUMP ONLY FOR HAIGHT MOTOR
12	F0254	2	PIN, COTTER HAIRPIN #213
13	F0255	1	PIN, CLEVIS 3/16 X 1-1/4
14	F0253	1	PIN, CLEVIS 3/16 X 1 3/4
15	SP0014	2	SPACER, ALUM .5 X .125
16	SP0034	2	SPACER, DRAIN VALVE BRKT FRYERS
17	NUT253	2	NUT, 6-32 S/S 18-8 NYLON
18	FT0022	1	PLUG, HOLE 3/8" LONG PRONG
19	LZ0130	1	SWITCH, ACT. COVER FKMA247
20	S0054	1	SWITCH, MICRO BZ-2RW822-A2
21	LPFFA093	1	HANDLE PLATE LPF-F #48
22	N0277	1	DECAL, HANDLE PLATE ALF LPF
23	SCR194	2	SCREW, 6-32 X 1 SL RD HD MS
24	H0214	1	HANDLE, DRAIN VALVE LPF
25	C0672	1	COVER, DRAIN HANDLE RED
26	SCR006	3	SCREW, 8 X 1/2 PHIL PAN HEAD
27	LPFFA092	1	ACTIVATOR ROD, FILL LPF-F #48
28	C0668	1	COVER, FILL HANDLE BLACK
29	P0081	1	PLUG, F-H4F4-7-7 QUIK DISCONN
30	B0851	1	BUSHING, BLK HEX REDUCING
31	ALFFA039	1	TUBE, VALVE TO COUPLING
32	FT0132	1	ELL, STREET 1/2 90 DEG BLACK
33	M0053	1	MOTOR, LEESON LESS CORD/PUMP

Figure 4. Control Panel ALF-F



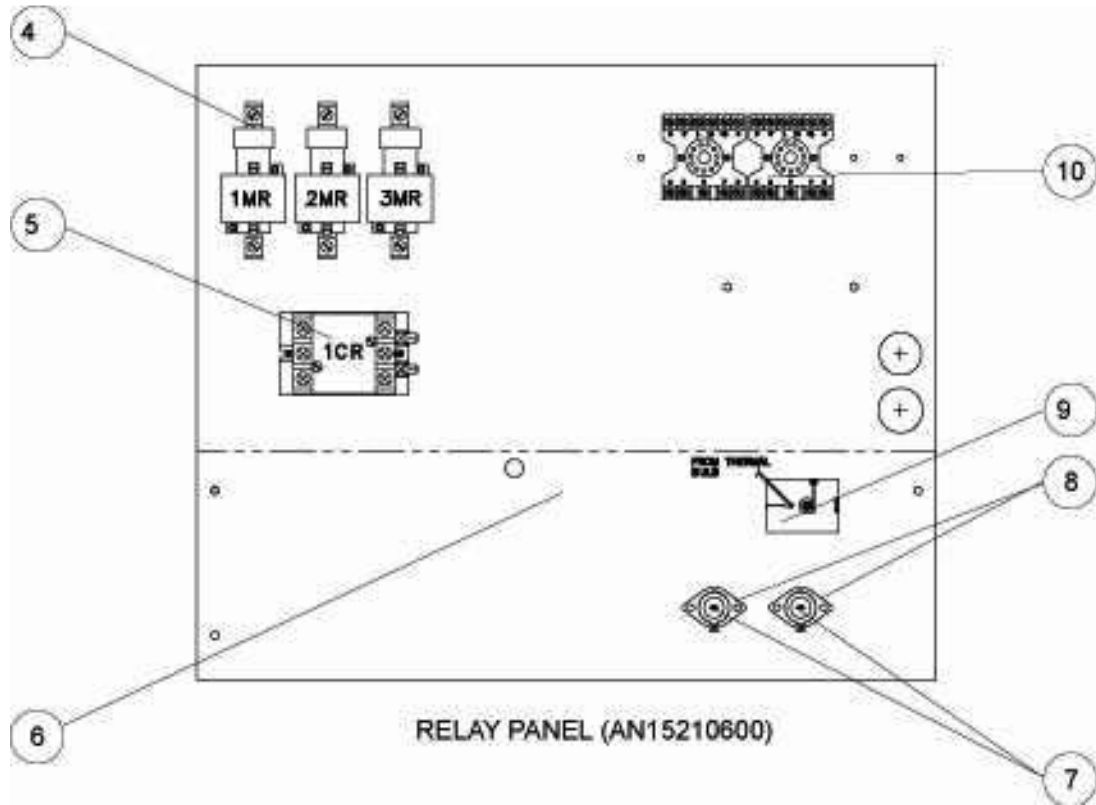
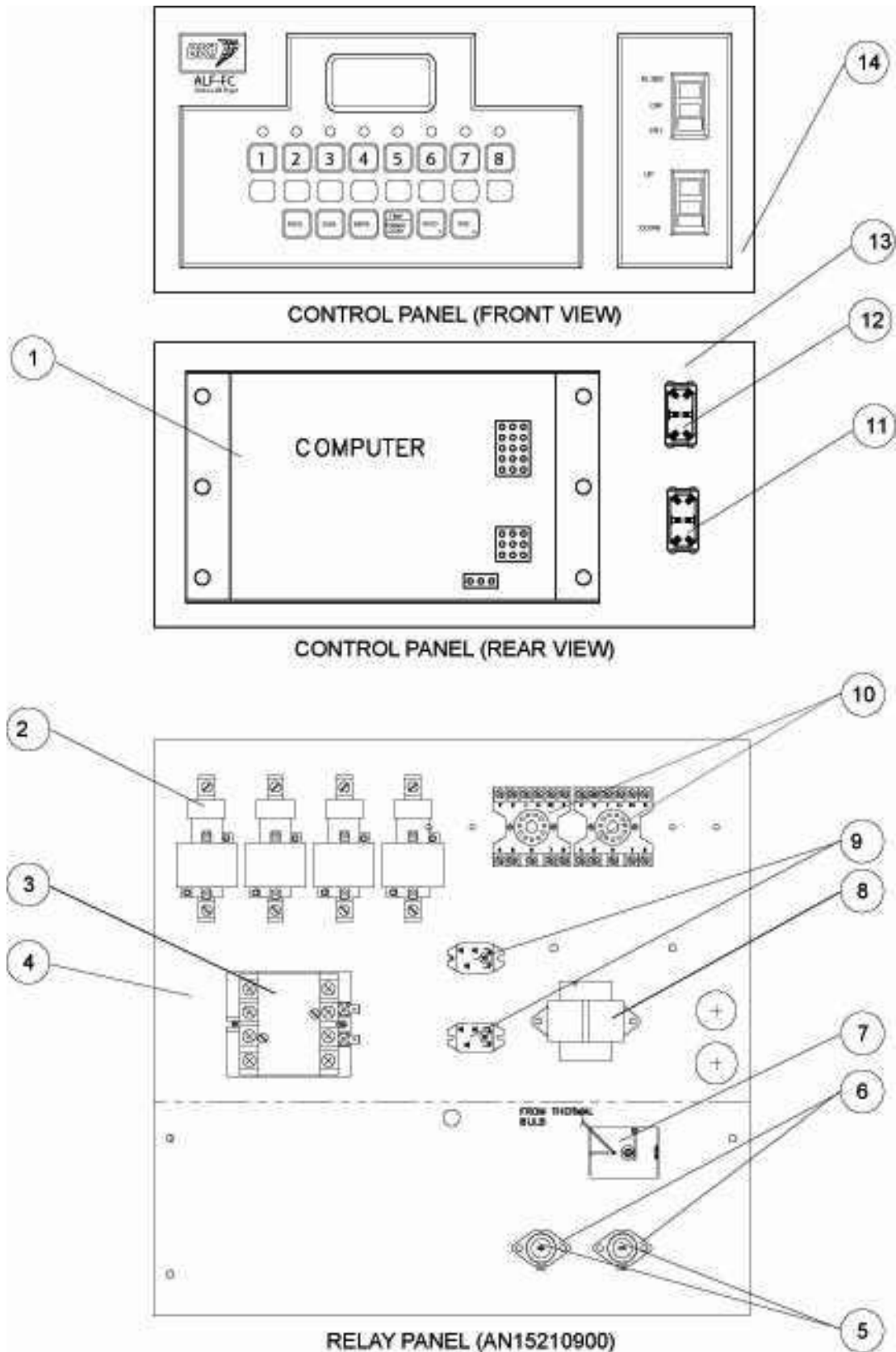

Table 4. Control Panel ALF-F Parts

ITEM #	PART #	QTY	DESCRIPTION
1	K0040	1	KNOB, S/S STRAT T0075
2	T0075	1	THERMOSTAT, SOLID STATE FRYER
3	PL0004	1	PILOT LIGHT, ROUND 250V
4	R0134	4	RELAY, MERCURY MDI 60NO220A (AN15210700)
	R0134	3	RELAY, MERCURY MDI 60NO220A (AN15210600)
5	R0150	1	RELAY, 4 POLE 208-240 60 HZ (AN15210700)
	R0148	1	RELAY, 3POLE 50A 208/240V FKM (AN15210600)
6	LPFA172	1	RELAY SUPPORT PANEL ALF LPF48
7	F0097	2	FUSE, 15A 300V SC15 TIME DELAY
8	FH0001	2	FUSE HOLDER, 15A 300V HPF-EE
9	T0036	1	THERMOSTAT, HI LIMIT 540 DEG
10	R0131	2	RELAY, PLUG IN 3PDT 240V COIL
11	TI0032	1	TIMER, 230V DIGITAL 4 BUTTON
12	S0104	1	SWITCH, RKR DPDT 15A 250V LAMP
13	S0127	1	SWITCH, ROCKER 2P, 3 POS
14	SB0197	1	CTL PNL WELD ALF-F
15	N0424	1	DECAL, CONTROL PANEL ALF LOGO

Figure 5. Control Panel ALF-FC



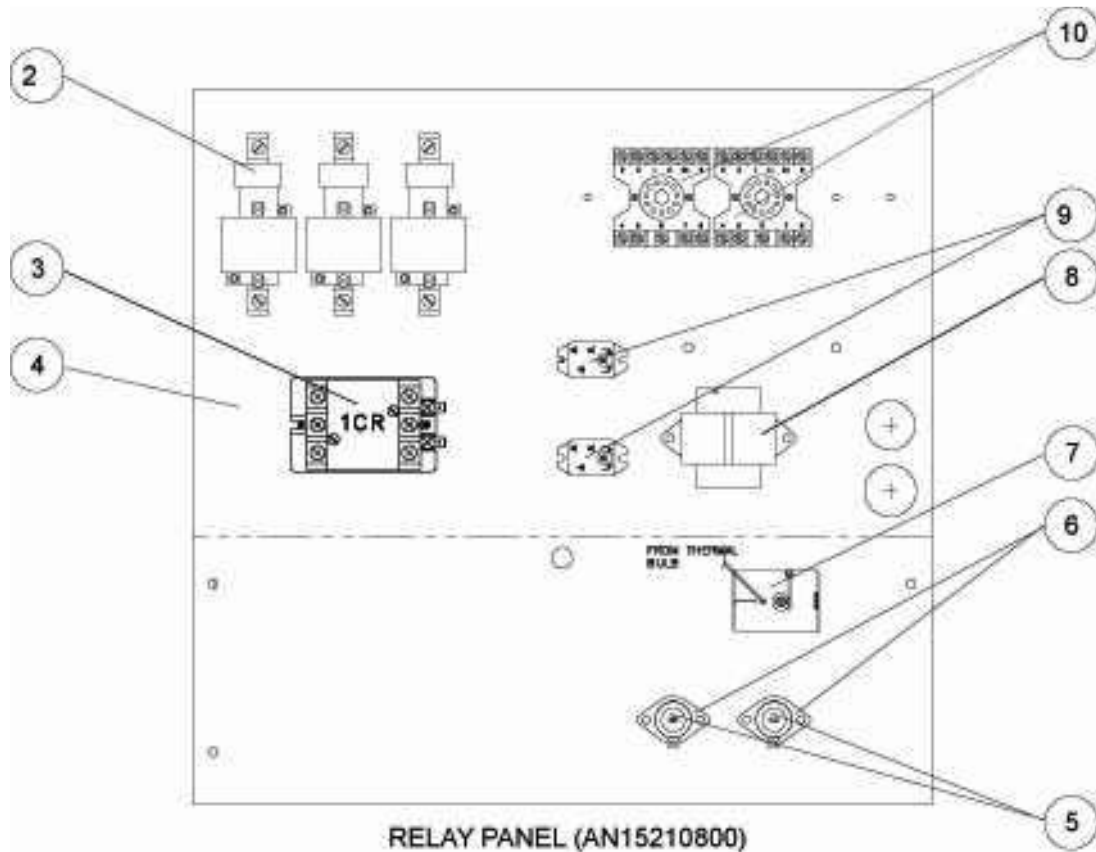

Table 5. Control Panel ALF-FC Parts

ITEM #	PART #	QTY	DESCRIPTION
1	CP0039	1	CONTROLLER, VFD LESS HARNESS
2	R0134	4	RELAY, MERCURY MDI 60NO220A (AN15210900)
	R0134	3	RELAY, MERCURY MDI 60NO220A (AN15210800)
3	R0150	1	RELAY, 4 POLE 208-240 60 HZ (AN15210900)
	R0148	1	RELAY, 3 POLE 42CF35AG (AN15210800)
4	SB1277	1	CTL PNL WELD ALF-FC
5	F0097	2	FUSE, 15A 300V SC15 TIME DELAY
6	FH0001	2	FUSE HOLDER, 15A 300V HPF-EE
7	T0036	1	THERMOSTAT, HI LIMIT 540 DEG
8	W0054	1	TRANSFORMER ASSY 240V
9	R0044	2	RELAY, X-40, SGL FRYER
10	R0131	2	RELAY, PLUG IN 3PDT 240V COIL
11	S0104	1	SWITCH, RKR DPDT 15A 250V LAMP
12	S0127	1	SWITCH, ROCKER 2P, 3 POS
13	LPFA172	1	RELAY SUPPORT PANEL ALF LPF48
14	N0407	1	DECAL, CONTROL PANEL ALFFC LOG

Figure 6. Oil Vat Assembly (AN86202800)

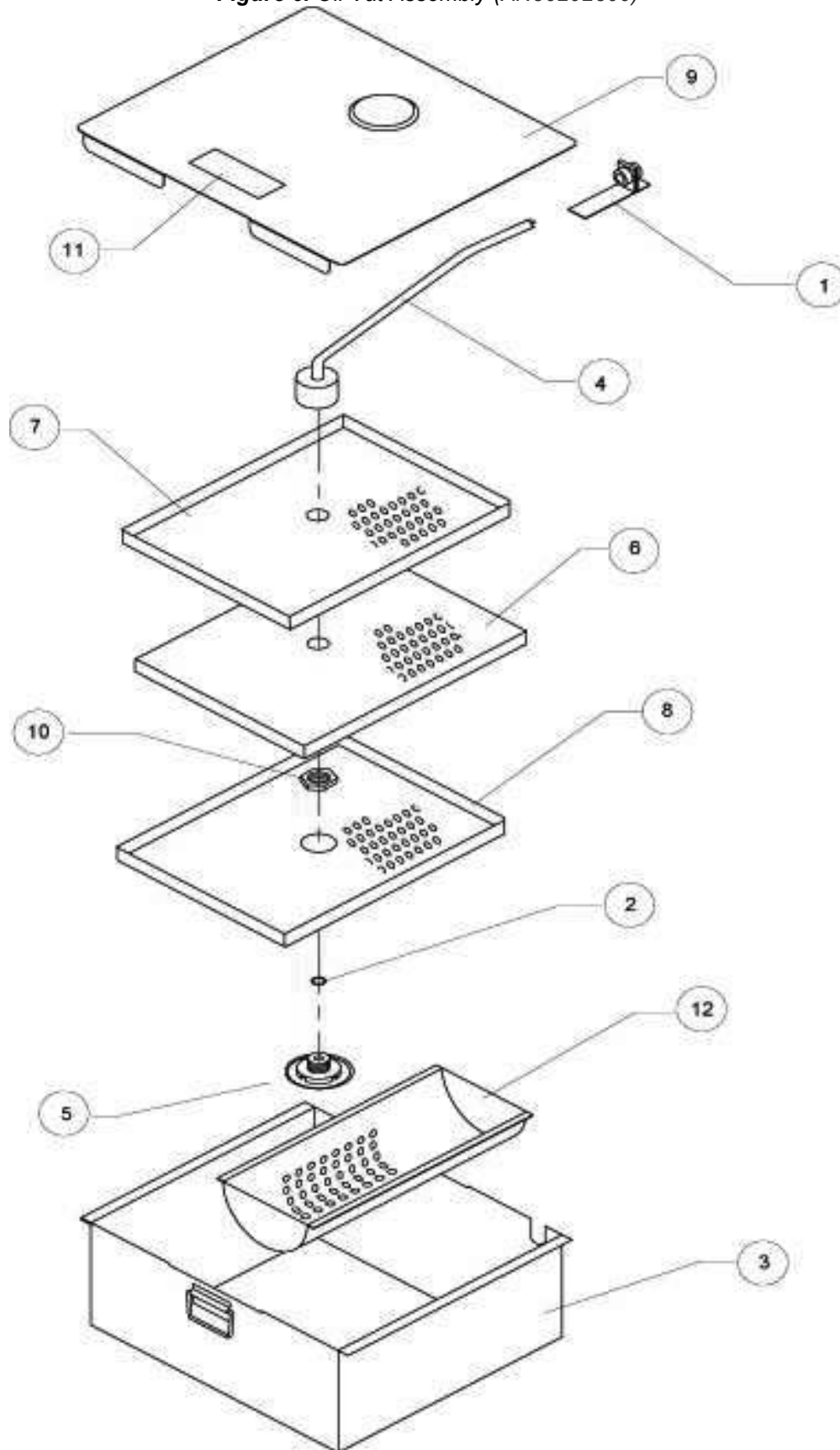

Table 6. Oil Vat Assembly (AN86202800) Parts

ITEM #	PART #	QTY	DESCRIPTION
1	SB1991	1	QUIK DISCONNECT BRACKET WELDMENT
2	O0013	1	O-RING, FLUOROCARBON V680-70
3	WB32112600	1	FILTER VAT WELD ALF LPF LGF
4	WB86202700	1	FILTER TUBING/DISCONN ALF LGF LPF
5	SB7659	1	FILTER SCREEN FITTING SPOTWELD
6	FS0002	1	FILTER SCREEN, INTERCEPTOR
7	FS0003	1	FILTER SCREEN, TOP
8	FS0001	1	FILTER SCREEN, BOTTOM
9	FB86202502	1	COVER, FILTER VAT LPF ALF
10	FC0004	1	NUT SCREEN RETAINING LPF-F &
11	N0395	1	DECAL, VAT COVER SAFETY WARN
12	SB2306	1	S/S CRUMB BASKET WELD

Figure 7. Quick Disconnect Assembly

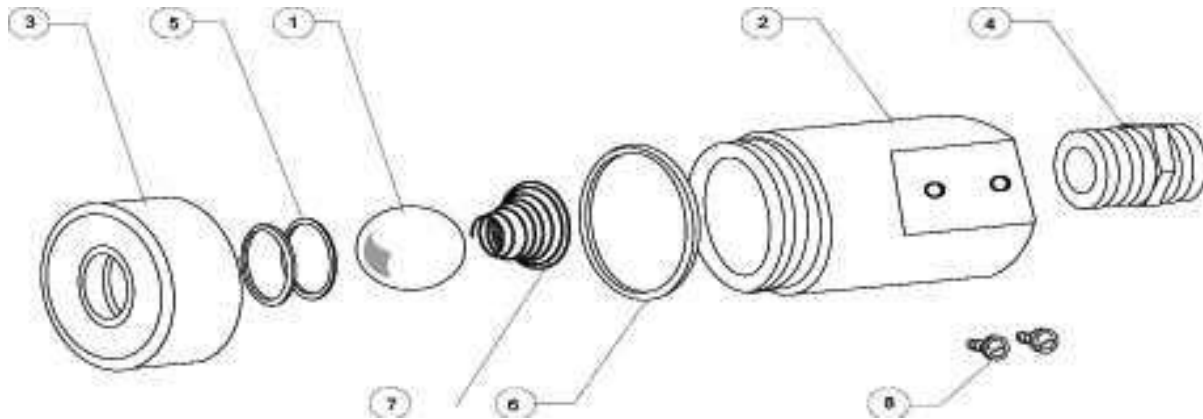

Table 7. Quick Disconnect Assembly Parts

ITEM #	PART #	QTY	DESCRIPTION
	AB86200700		
1	B0996	1	BALL, 11/16" STEEL BEARING
2	FT0429	1	QUICK DISCONNECT, PUMP SIDE
3	FT0500	1	QUICK DISCONNECT, VAT SIDE
4	FT0536	1	COUPLING, 5/8 45° FLARE TO
5	O0013	2	O-RING, FLUOROCARBON V680-70
6	O0014	1	O-RING, PARKER #2-124 LARGE
7	S0138	1	SPRING, FOR QUICK DISCONNECT
8	SCR453	2	SCREW, #10 24X3/8" WASHERED
	SB1997S		
1	B0996	1	BALL, 11/16" STEEL BEARING
2	FT0429	1	QUICK DISCONNECT, PUMP SIDE
3	FT0500	1	QUICK DISCONNECT, VAT SIDE
5	O0013	2	O-RING, FLUOROCARBON V680-70
6	O0014	1	O-RING, PARKER #2-124 LARGE
7	S0138	1	SPRING, FOR QUICK DISCONNECT

Components

Description	Component #	Figure #	Item #
CALROD, 208V 4500W LPF (W)	C0292	Figure 8	1
CALROD, 240V 4500W LPF (W)	C0294		
CASTER, 2470-DIK-075-R05/22	C0409	Figure 8	2
CASTER, 2477-DIK-075-R05/22	C0410	Figure 8	3
FILTER BAG CLIP FKM-F	ST0015	Figure 8	4
PROBE ASSEMBLY KIT, COMPUTER	SB1938	Figure 8	5
THERMISTER PROBE/FTGS ASSEMBLY	SB7656	Figure 8	6
COLLAR/LIFT ADJ WELD BLF	WA16015600	Figure 8	7
BASKET LIFT ARM LINEAR ACTUATOR WELD	WB15200300	Figure 8	8
MOTOR, BALL DRIVE ACTUATOR	M0084	Figure 8	9
CAPACITOR, 7.5 MFD 370 VAC	CP0102	Figure 8	10
HINGE, SLIP WING RH	H0051	Figure 8	11
HINGE, SLIP WING LH	H0052	Figure 8	12

Figure 8. Components



1



2



3



4



5



6



7



8



9



10



11



12

Accessories

Description	Accessory #	Figure #	Item #
BASKET, ALF USES LIFT HANDLE - option	B0115B	Figure 9	1
HANDLE, TEE STYLE LIFT	H0151	Figure 9	2
BRUSH, DRAIN (LONG WHITE)	B0075	Figure 9	3
BRUSH, L TIPPED 40152	B0063	Figure 9	4
BRUSH, POT SCRUBBER, WHITE	B0049	Figure 9	5
FILTER HOSE, FEMALE SOCKET - option	SB2332	Figure 9	6
GLOVE, NEOPRENE	G0089	Figure 9	7
FILTER, LPF-F 13.5 X 20.5	FI0007	Figure 9	8
BASKET, ALF BAIL HANDLE	B0113	Figure 9	9
FILTER VAT DOLLY ALF-F- option	AB15201100	Figure 9	10
RESTRAINT	FT0279	Figure 9	11
STORAGE COVER- option	SB1293	Figure 10	Table 8

Figure 9. Accessories



1



2

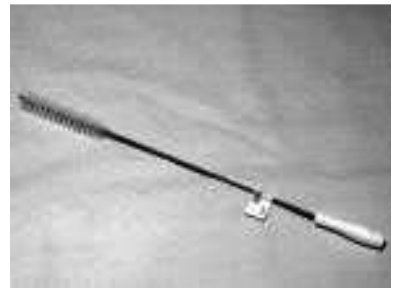

3



4



5



6



7

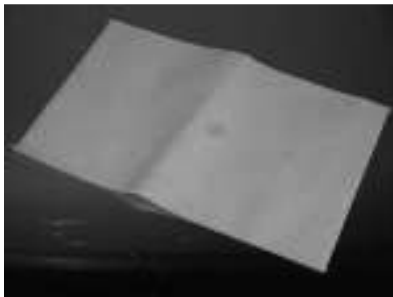

8



9



10

11

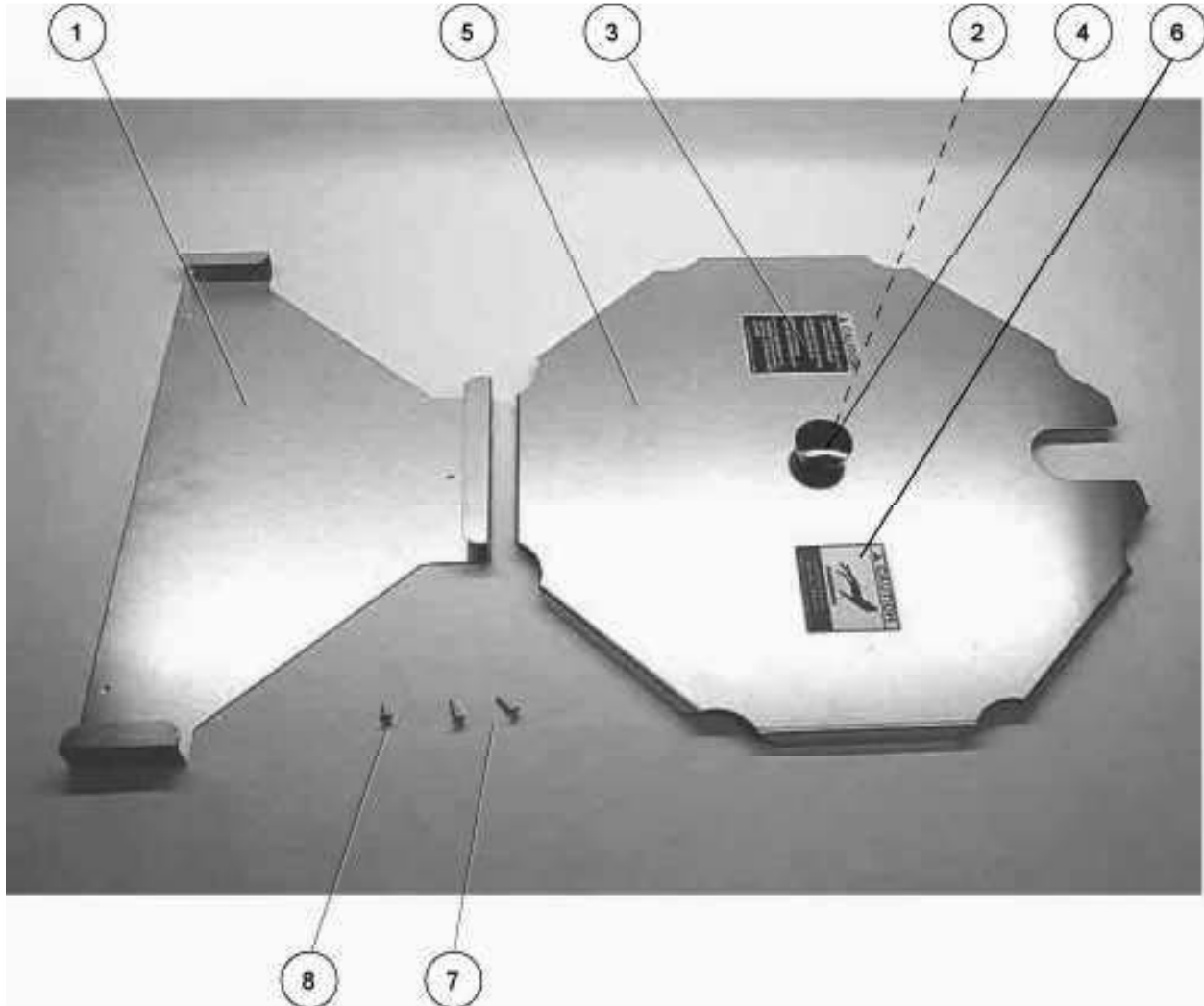
Figure 10. Storage Cover Assembly (Optional)**Table 8. Storage Cover Assembly Parts**

ITEM #	PART #	QTY	DESCRIPTION
1	ALFA123	1	HANGER, FRY POT COVER
2	SCR136	1	SCREW, 10-24 X 3/8 SLTD TRUSS
3	N0358	1	DECAL, BLF COVER CAUTION
4	K0044	1	KNOB, LARGE COVER, #3200
5	ALFA122	1	COVER, STORAGE ALF
6	N0162	1	DECAL, CAUTION HOT SURFACES
7	SCR007	2	SCREW, 8 X 3/4 PHIL TRUSS HD
8	SCR005	1	SCREW, 8 X 1/2 PHIL TRUSS HD

Wiring Diagrams

Refer to the table below to find the wiring diagram associated with your unit.

Wiring Diagram	Diagram #	Figure #	Page #
ALF-F 208V 1/3 Phase or ALF-F 240V 1/3 Phase	SB15290300	Figure 11	26
ALF-F 208V/240V/3 Phase	SB15290100	Figure 12	29
ALF-FC 208V 1/3 Phase or ALF-FC 240V 1/3 Phase	SB15290400	Figure 13	32
ALF-FC 208V/240V/3 Phase	SB15290200	Figure 14	35
ALF-F 208V/240V 60Hz 3 Phase	ALFE1027	Error! Reference source not found.	Error! Bookma rk not defined.

Figure 11. ALF-F 208V 1/3 Phase or ALF-F 240V 1/3 Phase (Sheet 1 of 3)

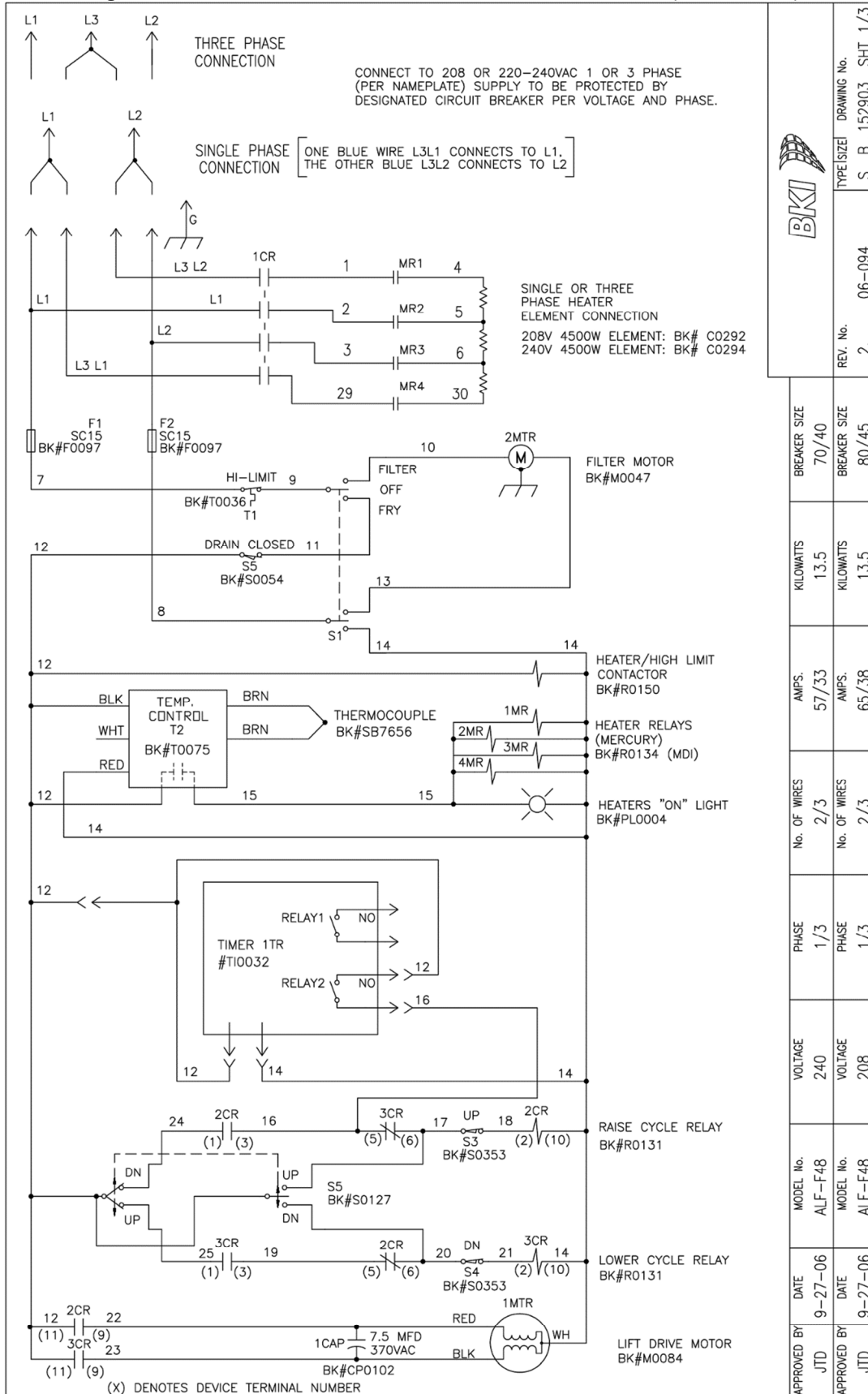

		TYPE/SIZE	DRAWING No.	
		S	B	152903
REV. No.		06-094		SHT 1/3
BREAKER SIZE		70/40		
KILOWATTS		13.5		
AMPS.		57/33		
No. OF WIRES		2/3		
PHASE		1/3		
VOLTAGE		240		
MODEL No.		ALF-F48		
DATE		9-27-06		
APPROVED BY		JTD		
BREAKER SIZE		80/45		
KILOWATTS		13.5		
AMPS.		65/38		
No. OF WIRES		2/3		
PHASE		1/3		
VOLTAGE		208		
MODEL No.		ALF-F48		
DATE		9-27-06		
APPROVED BY		JTD		

Figure 11. ALF-F 208V 1/3 Phase or ALF-F 240V 1/3 Phase (Sheet 3 of 3)

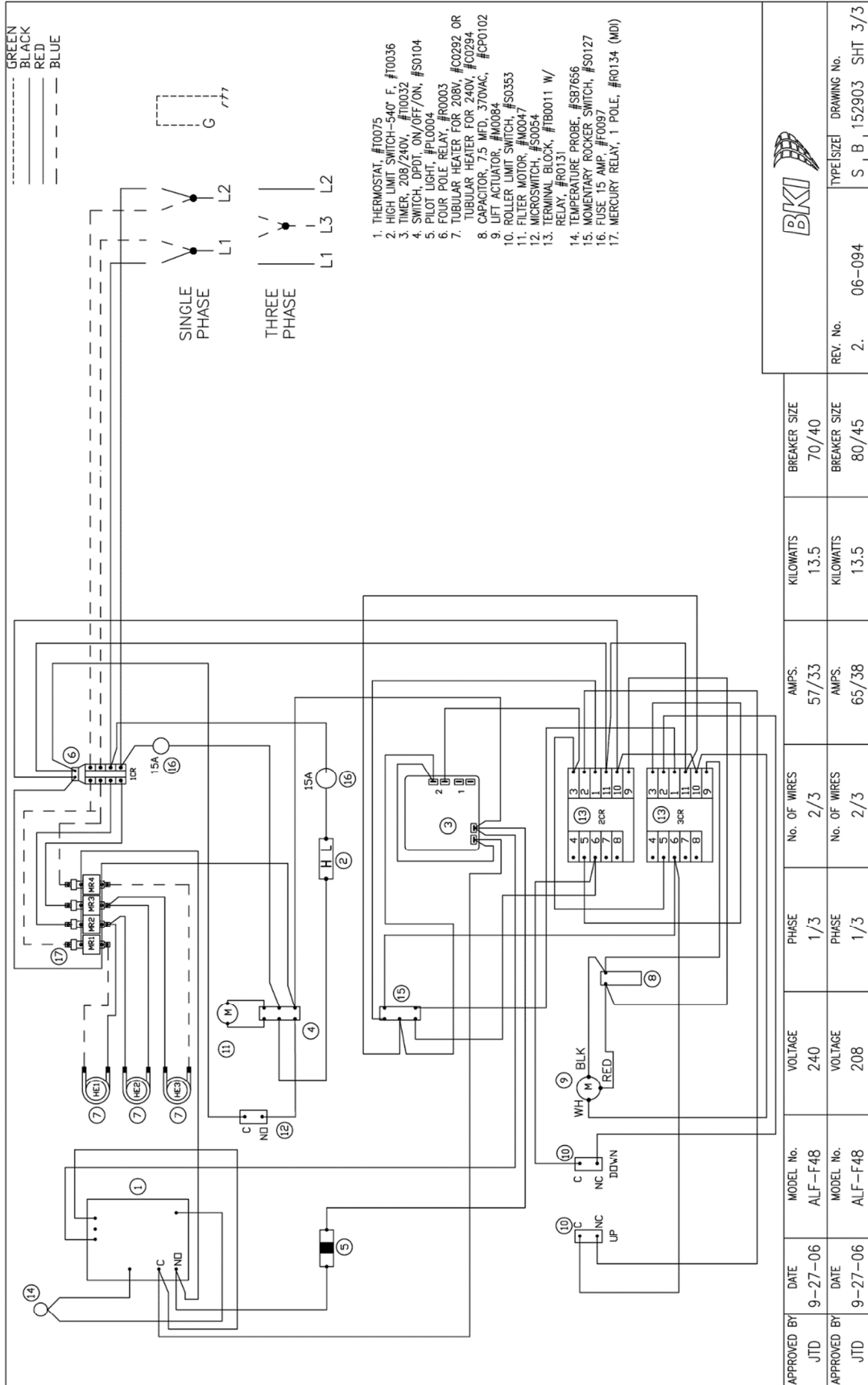

Figure 12. ALF-F 208V/240V/3 Phase (Sheet 1 of 3)

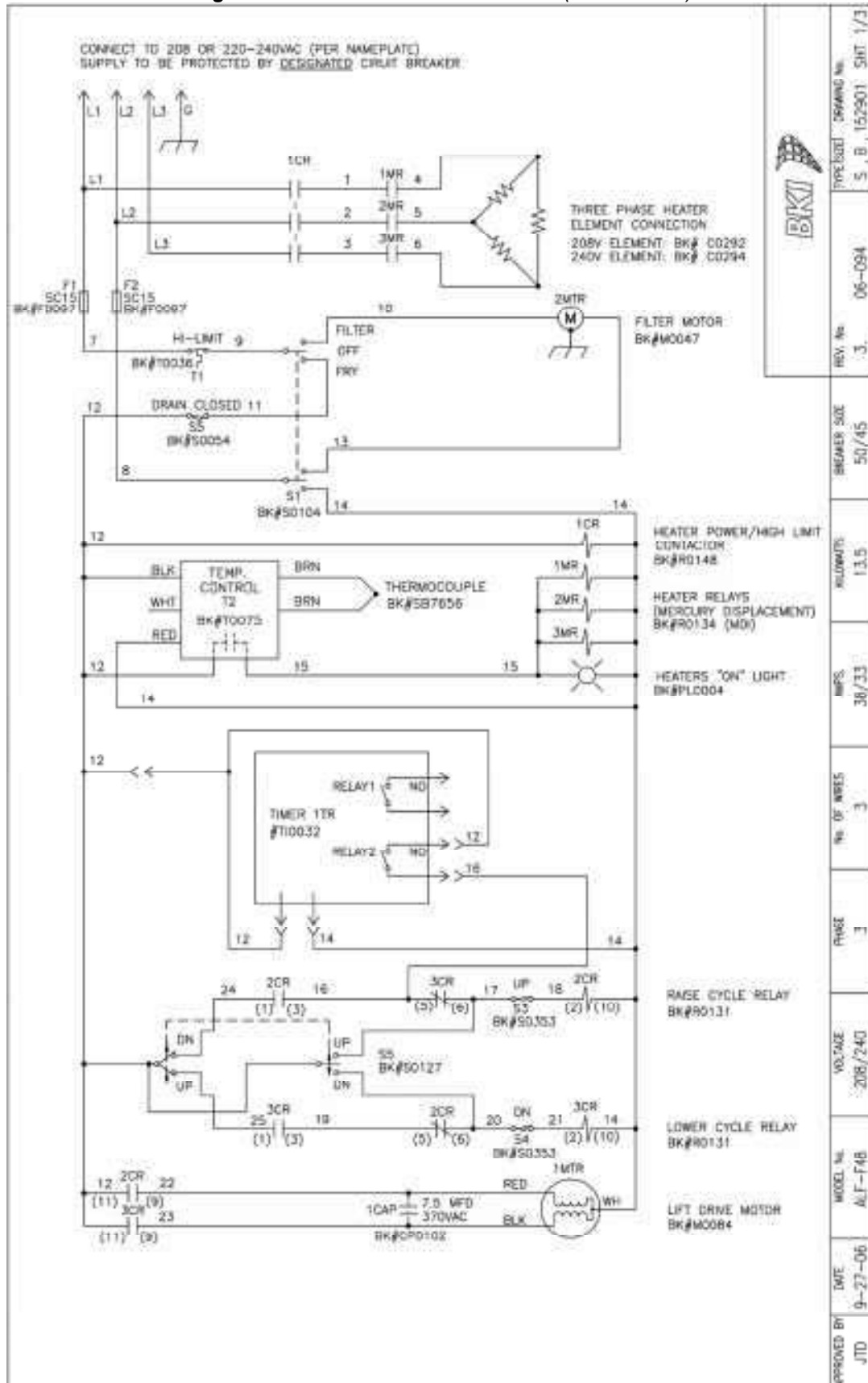

Figure 12. ALF-F 208V/240V/3 Phase (Sheet 2 of 3)

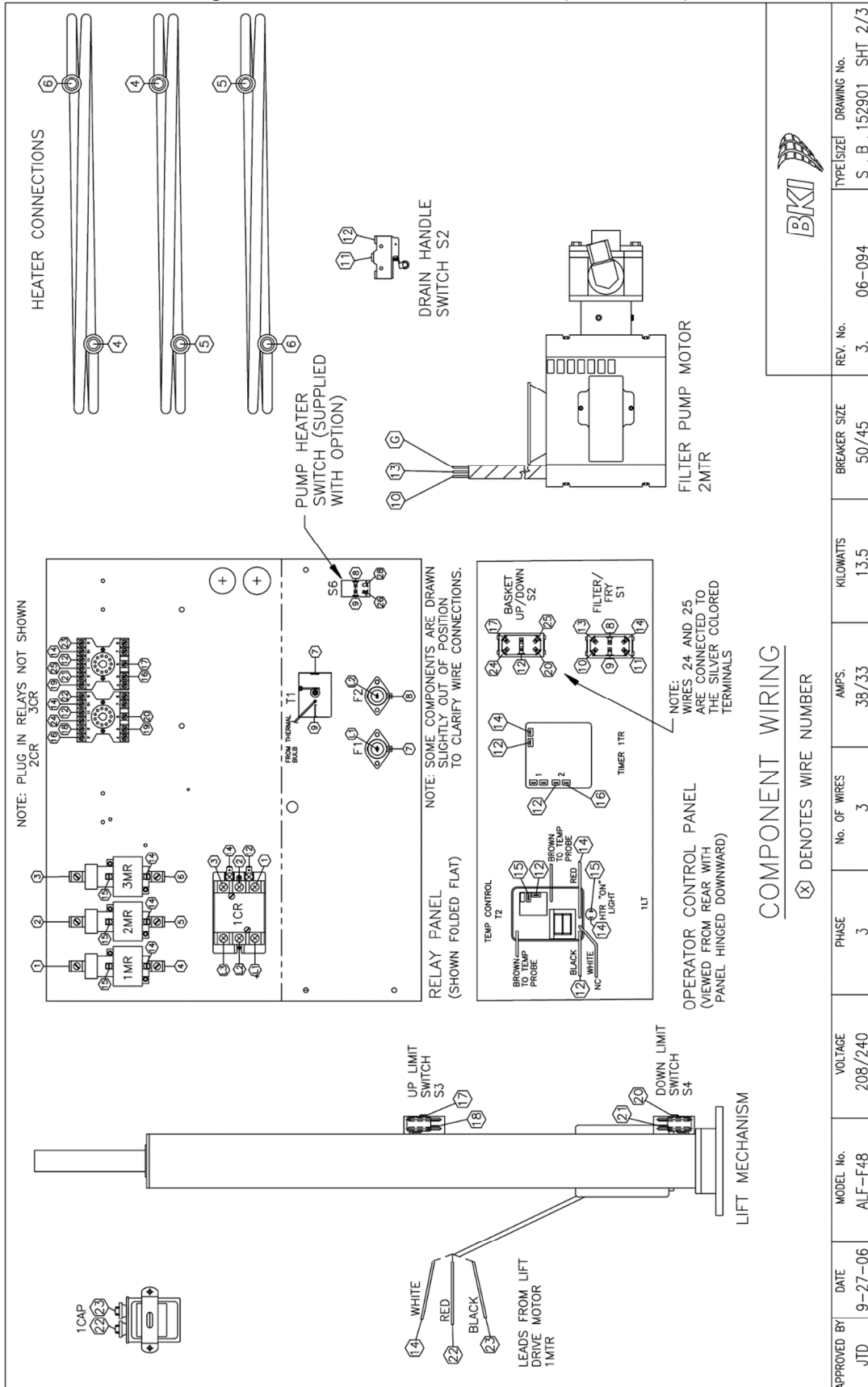

Figure 12. ALF-F 208V/240V/3 Phase (Sheet 3 of 3)

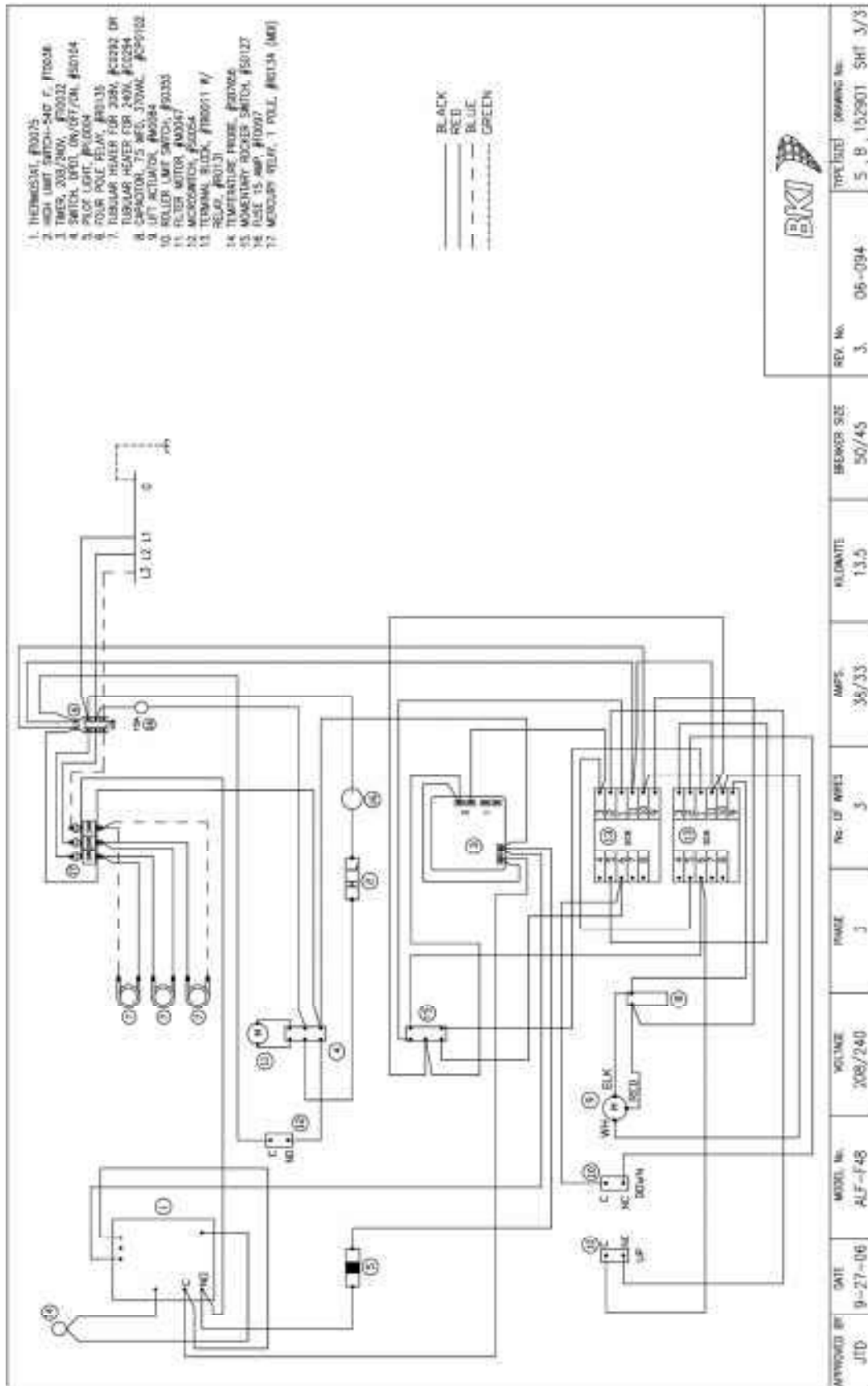

Figure 13. ALF-FC 208V 1/3 Phase or ALF-FC 240V 1/3 Phase (Sheet 1 of 3)

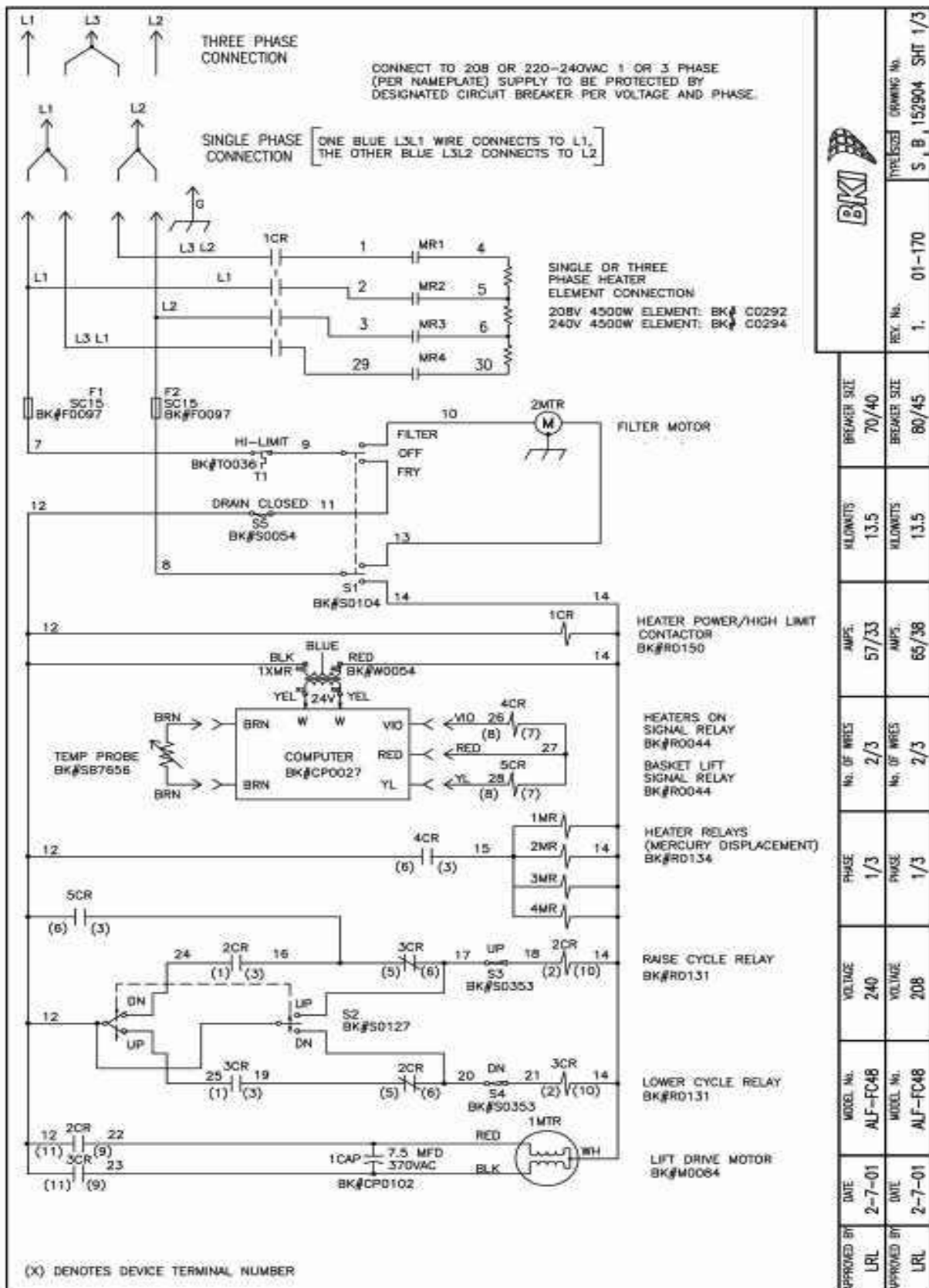

Figure 13. ALF-FC 208V 1/3 Phase or ALF-FC 240V 1/3 Phase (Sheet 2 of 3)

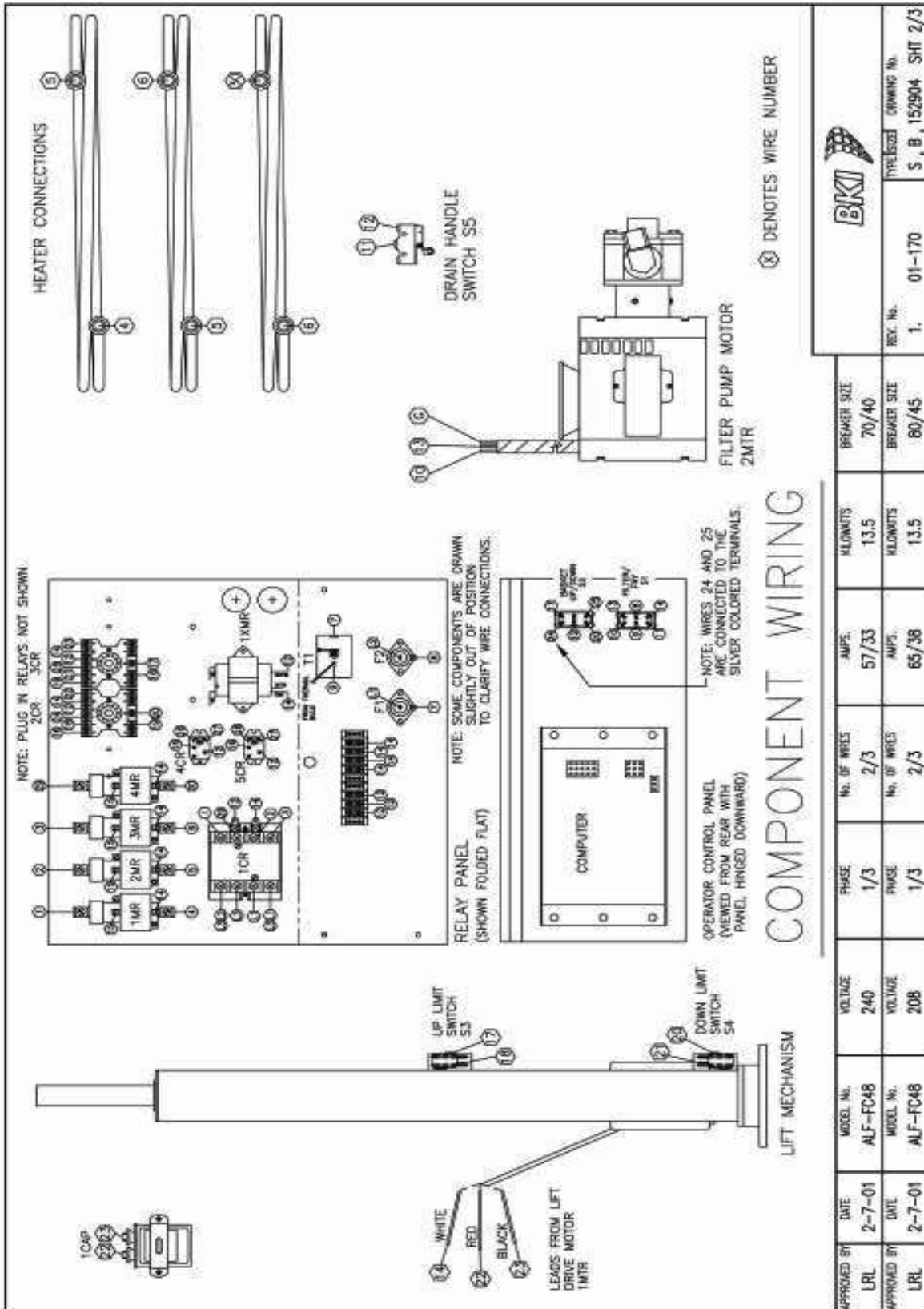

Figure 13. ALF-FC 208V 1/3 Phase or ALF-FC 240V 1/3 Phase (Sheet 3 of 3)

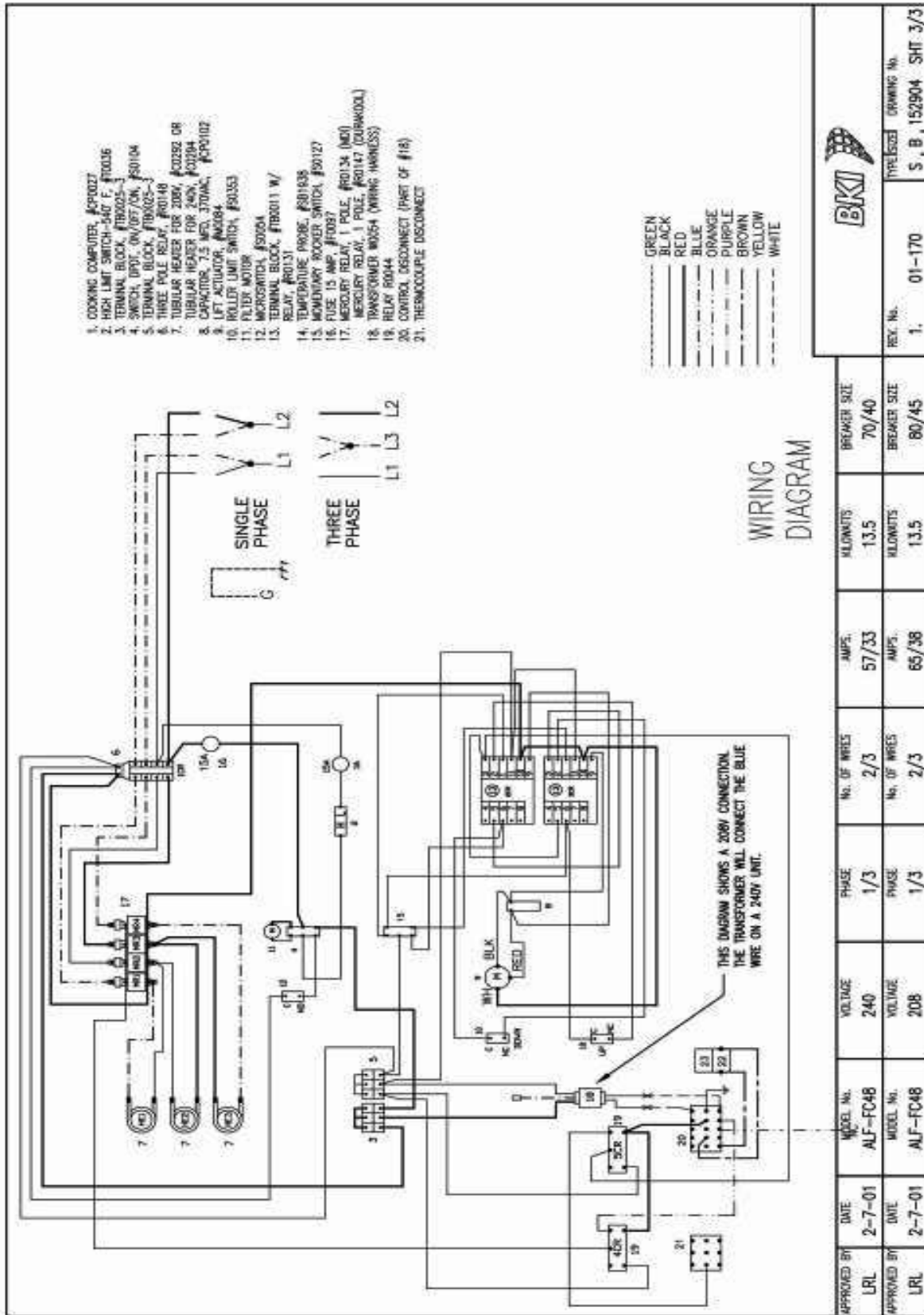

Figure 14. ALF-FC 208V/240V/3 Phase (sheet 1 of 3)

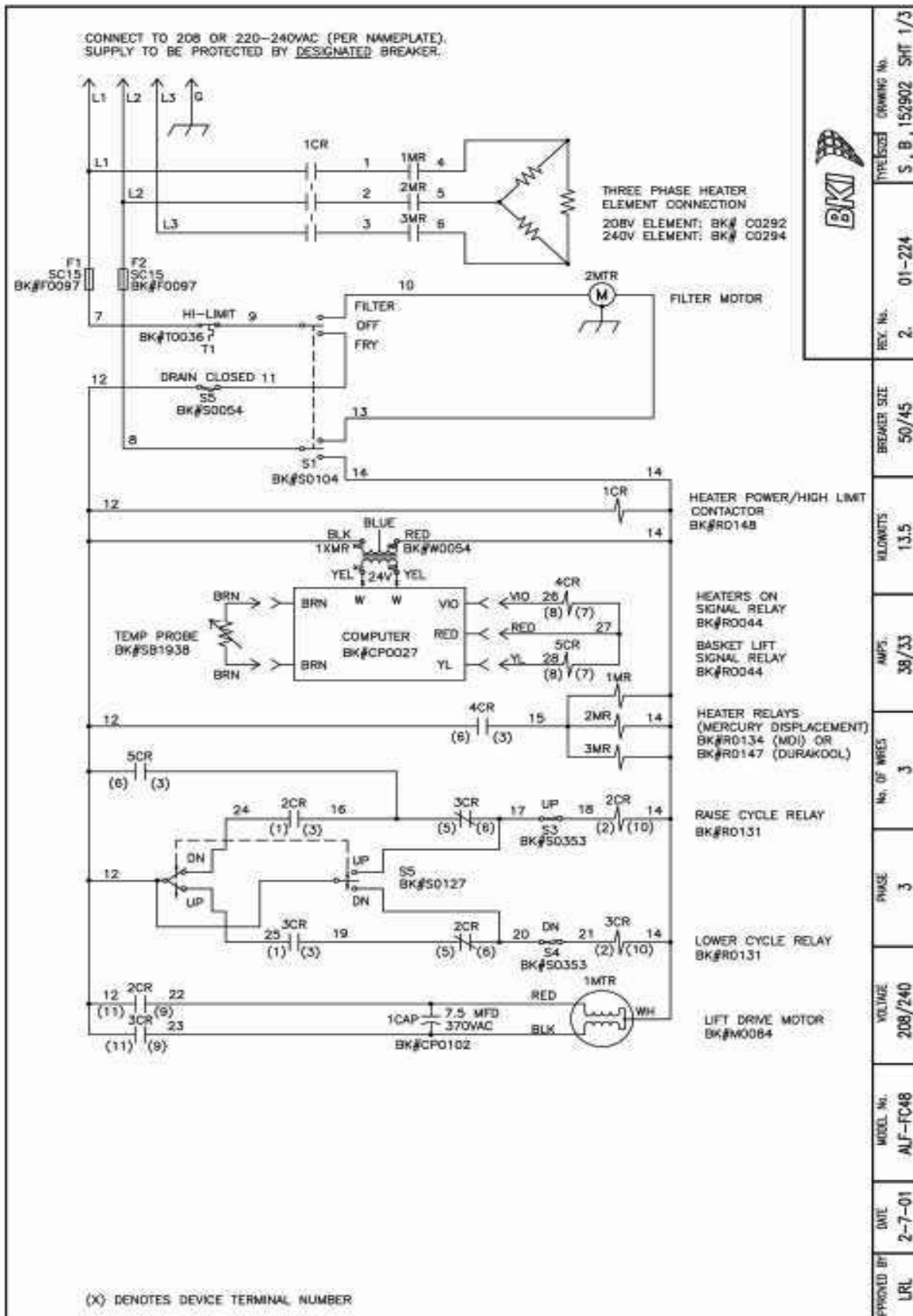

Figure 14. ALF-FC 208V/240V/3 Phase (sheet 2 of 3)

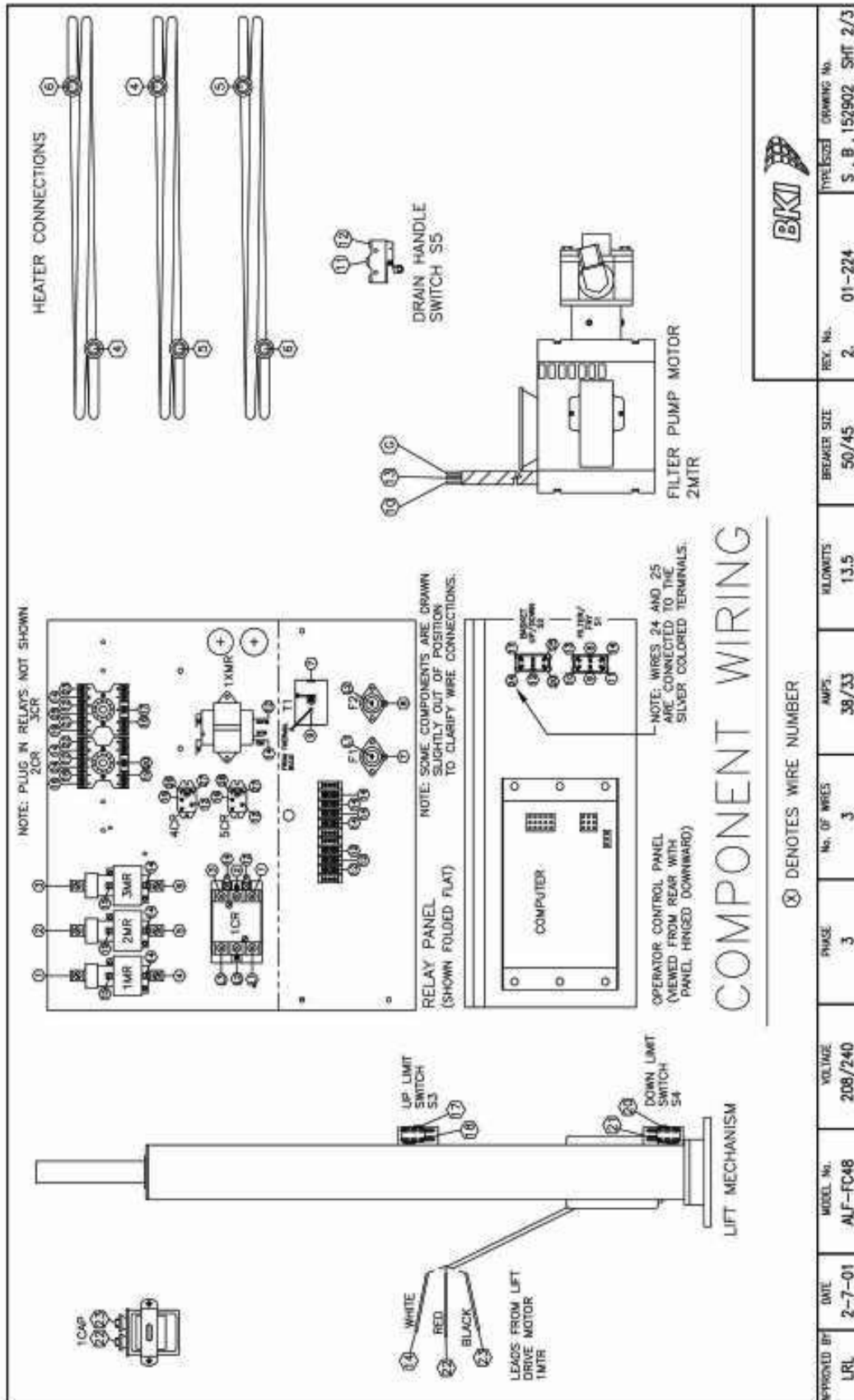
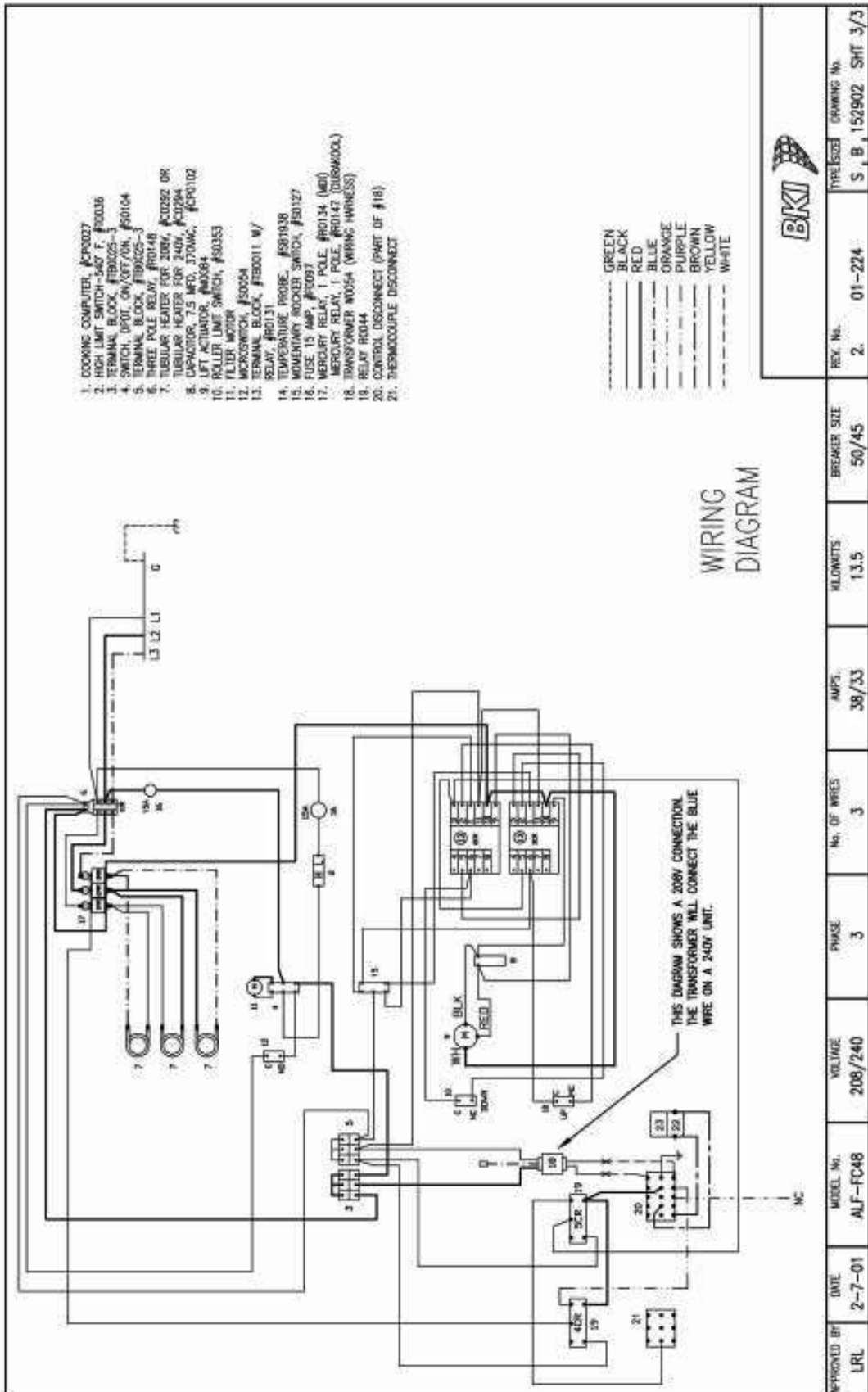

Figure 14. ALF-FC 208V/240V/3 Phase (sheet 3 of 3)



APPROVED BY	DATE	MODEL No.	VOLTAGE	PHASE	No. OF WIRES	AMPS	FEET/INCHES	BREAKER SIZE	REV. No.	DRAWING No.
LRL	2-7-01	ALF-FC48	208/240	3	3	39/33	13.5	50/45	2.	01-224 SHT 3/3

Figure 15. ALF-F 208V/240V 60Hz, 3 Phase (sheet 1 of 3)

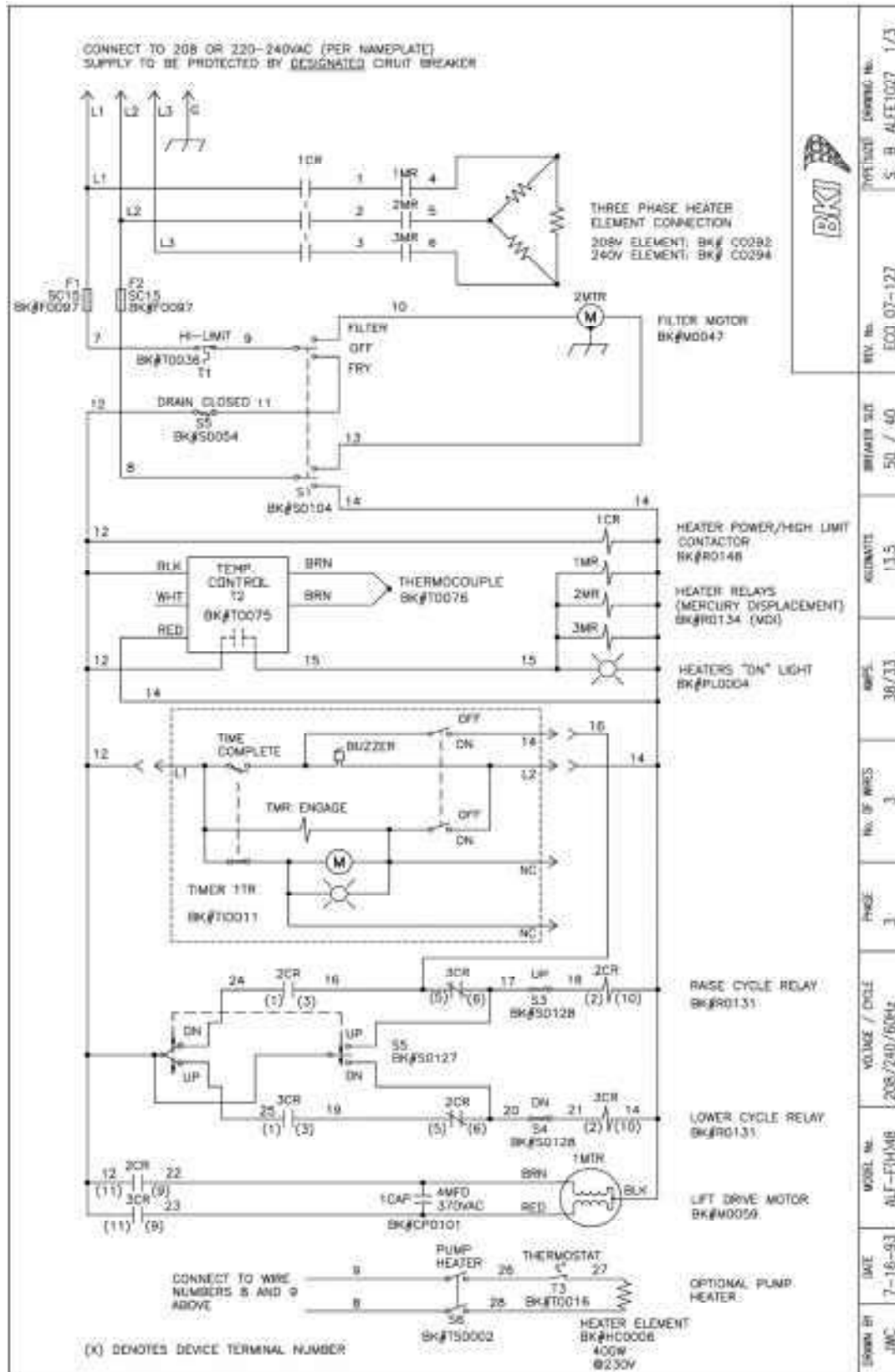

Figure 15. ALF-F 208V/240V 60Hz, 3 Phase (sheet 2 of 3)

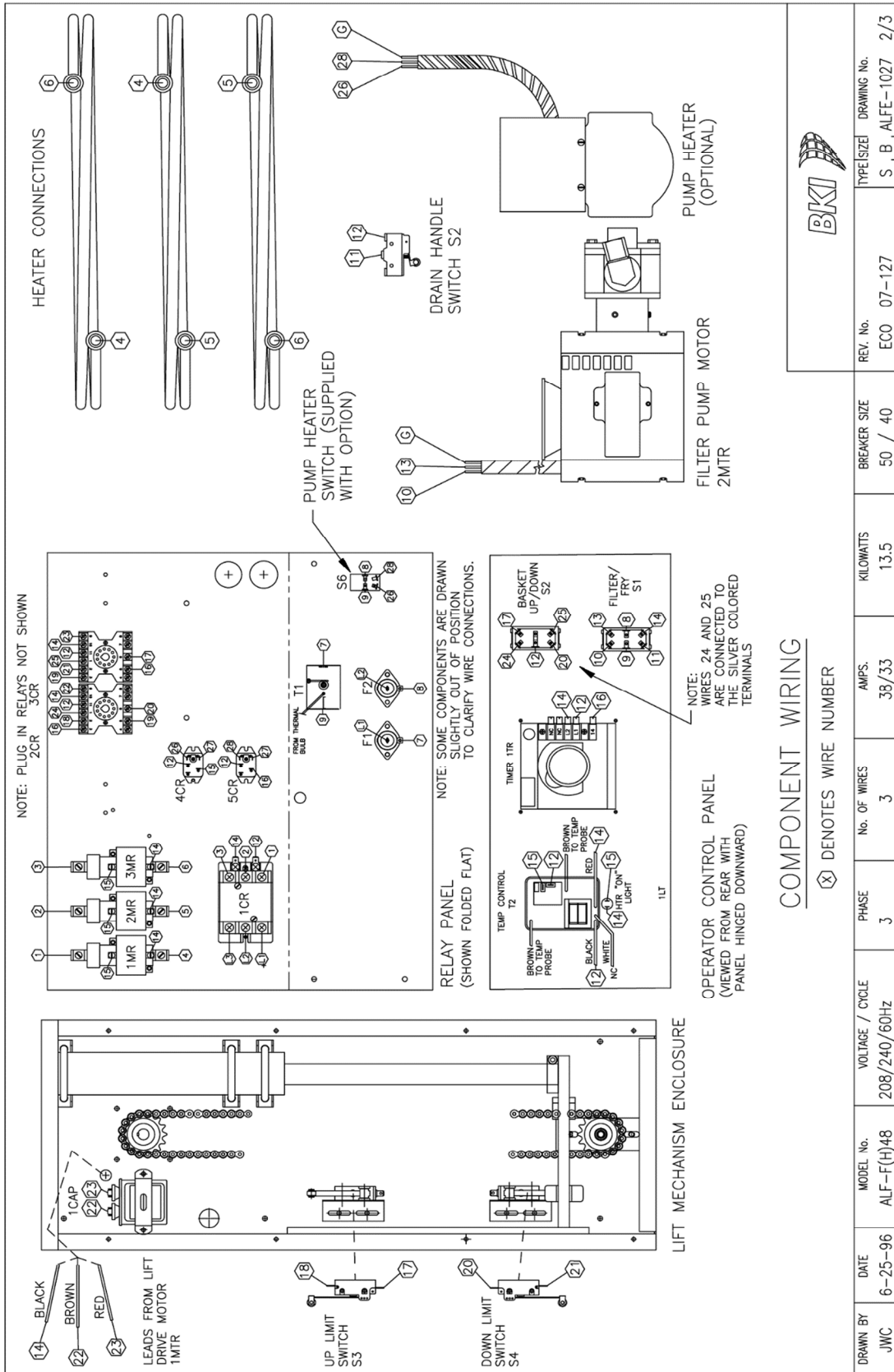
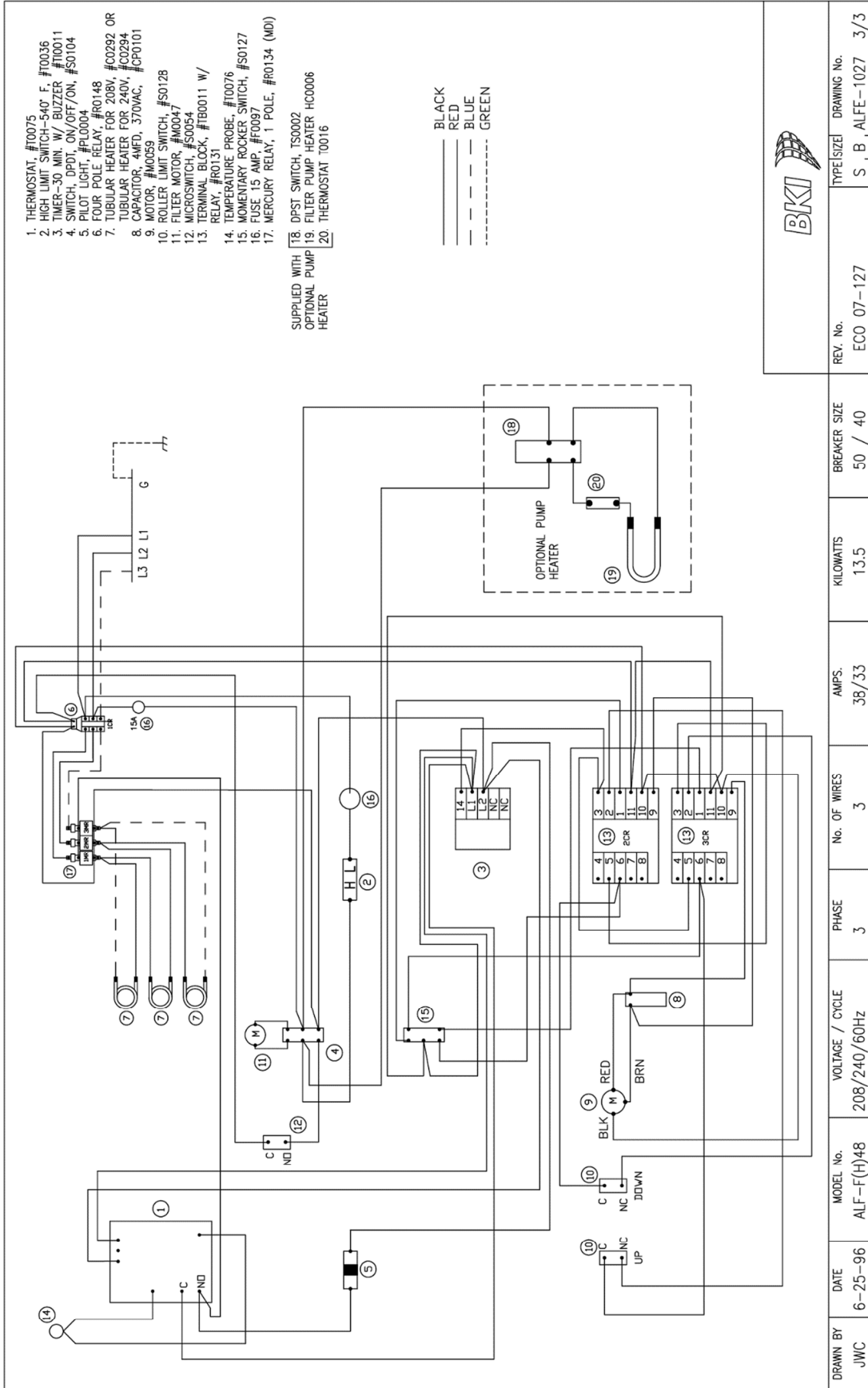

Figure 15. ALF-F 208V/240V 60Hz, 3 Phase (sheet 3 of 3)



DATE	MODEL No.	VOLTAGE / CYCLE	PHASE	No. OF WIRES	AMPS.	KILOWATTS	BREAKER SIZE	REV. No.	TYPE/SIZE	DRAWING No.
6-25-96	ALF-F(H)48	208/240/60Hz	3	3	38/33	13.5	50 / 40	ECO 07-127	S B	ALFE-1027 3/3



2812 Grandview Dr., Simpsonville, S.C. 29680, USA
<http://www.bkideas.com>

Made and printed in the U.S.A.

CS-TM-009.02

Revised 01/05/2015

NOTES: