

Convection Oven

MODEL CO

Service Manual

Serial Numbers 120317 and higher



BKI LIMITED WARRANTY

2812 Grandview Dr. • Simpsonville, SC 29680 • USA
(864) 963-3471 • Toll Free: (800) 927-6887 • Fax: (864) 963-5316

WHAT IS COVERED	<p>This warranty covers defects in material and workmanship under normal use, and applies only to the original purchaser providing that:</p> <ul style="list-style-type: none">☐ The equipment has not been accidentally or intentionally damaged, altered or misused;☐ The equipment is properly installed, adjusted, operated and maintained in accordance with national and local codes, and in accordance with the installation and operating instructions provided with this product.☐ The serial number rating plate affixed to the equipment has not been defaced or removed.
WHO IS COVERED	<p>This warranty is extended to the original purchaser and applies only to equipment purchased for use in the U.S.A.</p>
COVERAGE PERIOD	<ul style="list-style-type: none">☐ Warranty claims must be received in writing by BKI within one (1) year from date of installation or within one (1) year and three (3) months from data of shipment from the factory, whichever comes first.☐ COB Models: One (1) Year limited parts and labor.☐ COM Models: Two (2) Year limited parts and labor. COM convection ovens also have a two (2) year door warranty.☐ CO1 Models: Two (2) Year limited parts and labor. Five (5) Year limited door warranty.☐ BevLes Products: Two (2) Year limited parts and labor.☐ Warranty period begins the date of dealer invoice to customer or ninety (90) days after shipment date from BKI, whichever comes first.
WARRANTY COVERAGE	<p>This warranty covers on-site labor, parts and reasonable travel time and travel expenses of the authorized service representative up to (100) miles round trip and (2) hours travel time and performed during regular, weekday business hours.</p>
EXCEPTIONS	<p>Any exceptions must be pre-approved in advance and in writing by BKI. The extended door warranty on convection ovens years 3 through 5 is a parts only warranty and does not include labor, travel, mileage or any other charges.</p>
EXCLUSIONS	<ul style="list-style-type: none">☐ Negligence or acts of God,☐ Thermostat calibrations after (30) days from equipment installation date,☐ Air and gas adjustments,☐ Light bulbs,☐ Glass doors and door adjustments,☐ Fuses,☐ Adjustments to burner flames and cleaning of pilot burners,☐ Tightening of screws or fasteners,☐ Failures caused by erratic voltages or gas suppliers,☐ Unauthorized repair by anyone other than a BKI Factory Authorized Service Center,☐ Damage in shipment,☐ Alteration, misuse or improper installation,☐ Thermostats and safety valves with broken capillary tubes,☐ Freight - other than normal UPS charges,☐ Ordinary wear and tear,☐ Failure to follow installation and/or operating instructions,☐ Events beyond control of the company.
INSTALLATION	<p>Leveling, as well as proper installation and check out of all new equipment - per appropriate installation and use materials - is the responsibility of the dealer or installer, not the manufacturer.</p>
REPLACEMENT PARTS	<p>BKI genuine Factory OEM parts receive a (90) day materials warranty effective from the date of installation by a BKI Factory Authorized Service Center.</p>

Table of Contents

Table of Contents	1
Introduction.....	2
Safety Precautions	2
Safety Signs and Messages	2
Safe Work Practices	3
Safety Decals.....	5
Health And Sanitation Practices	7
Food Handling.....	7
Storage Of Raw Meats	7
Coding Cooked Foods	7
Storage Of Prepared Foods.....	7
Installation.....	8
Unpacking and Handling	8
Location and Clearance	8
Wiring	8
Replacement Parts	9
Assemblies	9
Components	19
Wiring Diagrams	20

Introduction

Congratulations! You have chosen a **Convection Oven** that will give you many years of fine service from the original manufacturer, **BKI**.

The **BKI** name and trademark on this unit assures you of the finest in design and engineering -- that it has been built with care and dedication -- using the best materials available. Attention to the operating instructions regarding proper installation, operation, and maintenance will result in long lasting dependability to insure the highest profitable return on your investment.

NOTICE

PLEASE READ THIS ENTIRE MANUAL BEFORE OPERATING THE UNIT. If you have any questions, please contact your BKI Distributor. If they are unable to answer your questions, contact the BKI Technical Service Department, toll free: 1-800-927-6887. Outside the U.S., call 1-864-963-3471.

Safety Precautions

Always follow recommended safety precautions listed in this manual. Below is the safety alert symbol. When you see this symbol on your equipment, be alert to the potential for personal injury or property damage.



Safety Signs and Messages

The following Safety signs and messages are placed in this manual to provide instructions and identify specific areas where potential hazards exist and special precautions should be taken. Know and understand the meaning of these instructions, signs, and messages. Damage to the equipment, death or serious injury to you or other persons may result if these messages are not followed.

⚠ DANGER

This message indicates an imminently hazardous situation, which, if not avoided, will result in death or serious injury.

⚠ WARNING

This message indicates a potentially hazardous situation, which, if not avoided, could result in death or serious injury.

⚠ CAUTION

This message indicates a potentially hazardous situation, which, if not avoided, may result in minor or moderate injury. It may also be used to alert against unsafe practices.

NOTICE

This message is used when special information, instructions or identification are required relating to procedures, equipment, tools, capacities and other special data.

Safe Work Practices

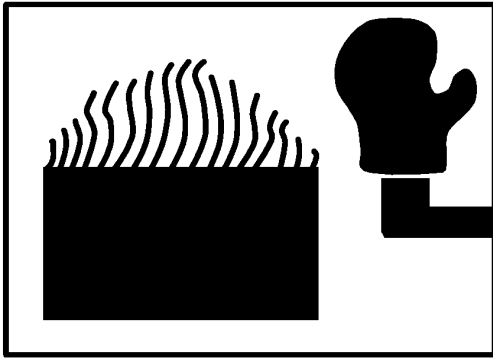

Wear Safe Clothing Appropriate To Your Job

Always wear your insulated mitts when handling hot racks or touch any hot metal surface. If you lose or damage your mitts, you can buy new ones at your local restaurant equipment supply store or from your local BKI Distributor.

Never wear loose clothing such as neckties or scarves while operating this equipment. Keep loose hair tied back or in a hair net while operating this equipment.

Always wear appropriate personal protection equipment during the cleaning process to guard against possible injury from hot cleaning solution.

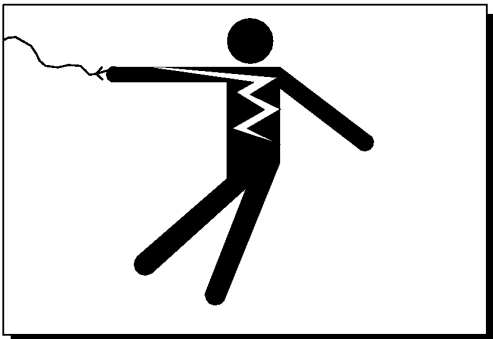

Beware of High Voltage

This equipment uses high voltage. Serious injury can occur if you or any untrained or unauthorized person installs, services, or repairs this equipment. Always use an Authorized Service agent to service your equipment.

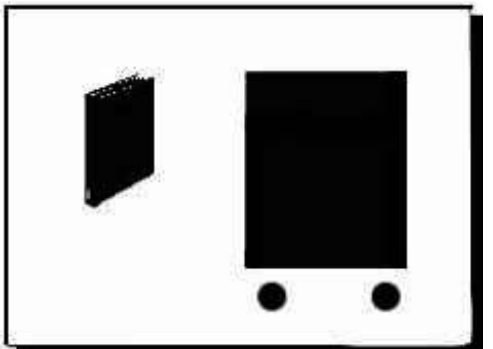

Keep this manual with the Equipment

This manual is an important part of your equipment. Always keep it near for easy access.

If you need to replace this manual, contact:

BKI
 Technical Services Department
 2812 Grandview Drive
 Simpsonville, S.C. 29680
 Or call toll free: 1-800-927-6887
 Outside the U.S., call 864-963-3471



Protect Children

Keep children away from this equipment. Children may not understand that this equipment is dangerous for them and others.

NEVER allow children to play near or operate your equipment.

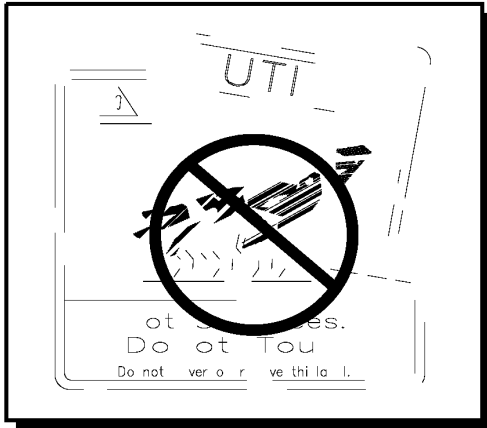

Keep Safety Labels Clean and in Good Condition

Do not remove or cover any safety labels on your equipment. Keep all safety labels clean and in good condition. Replace any damaged or missing safety labels. Refer to the Safety Labels section for illustration and location of safety labels on this unit.

If you need a new safety label, obtain the number of the specific label illustrated on page 5, then contact:

BKI
 Technical Services Department
 2812 Grandview Drive
 Simpsonville, S.C. 29680
 Or call toll free: 1-800-927-6887
 Outside the U.S., call 864-963-3471

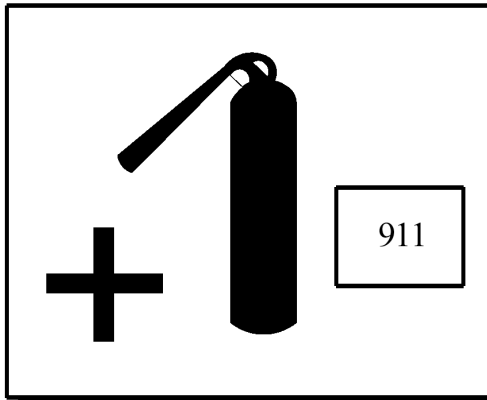

Be Prepared for Emergencies

Be prepared for fires, injuries, or other emergencies.

Keep a first aid kit and a fire extinguisher near the equipment. You must use a 40-pound Type BC fire extinguisher and keep it within 25 feet of your equipment.

Keep emergency numbers for doctors, ambulance services, hospitals, and the fire department near your telephone.

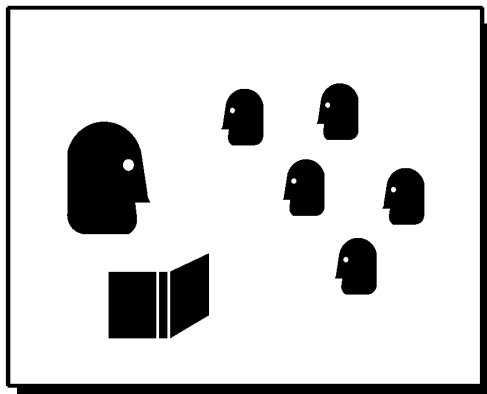

Know your responsibilities as an Employer

- Make certain your employees know how to operate the equipment.
- Make certain your employees are aware of the safety precautions on the equipment and in this manual.
- Make certain that you have thoroughly trained your employees about operating the equipment safely.
- Make certain the equipment is in proper working condition. If you make unauthorized modifications to the equipment, you will reduce the function and safety of the equipment.

Safety Decals

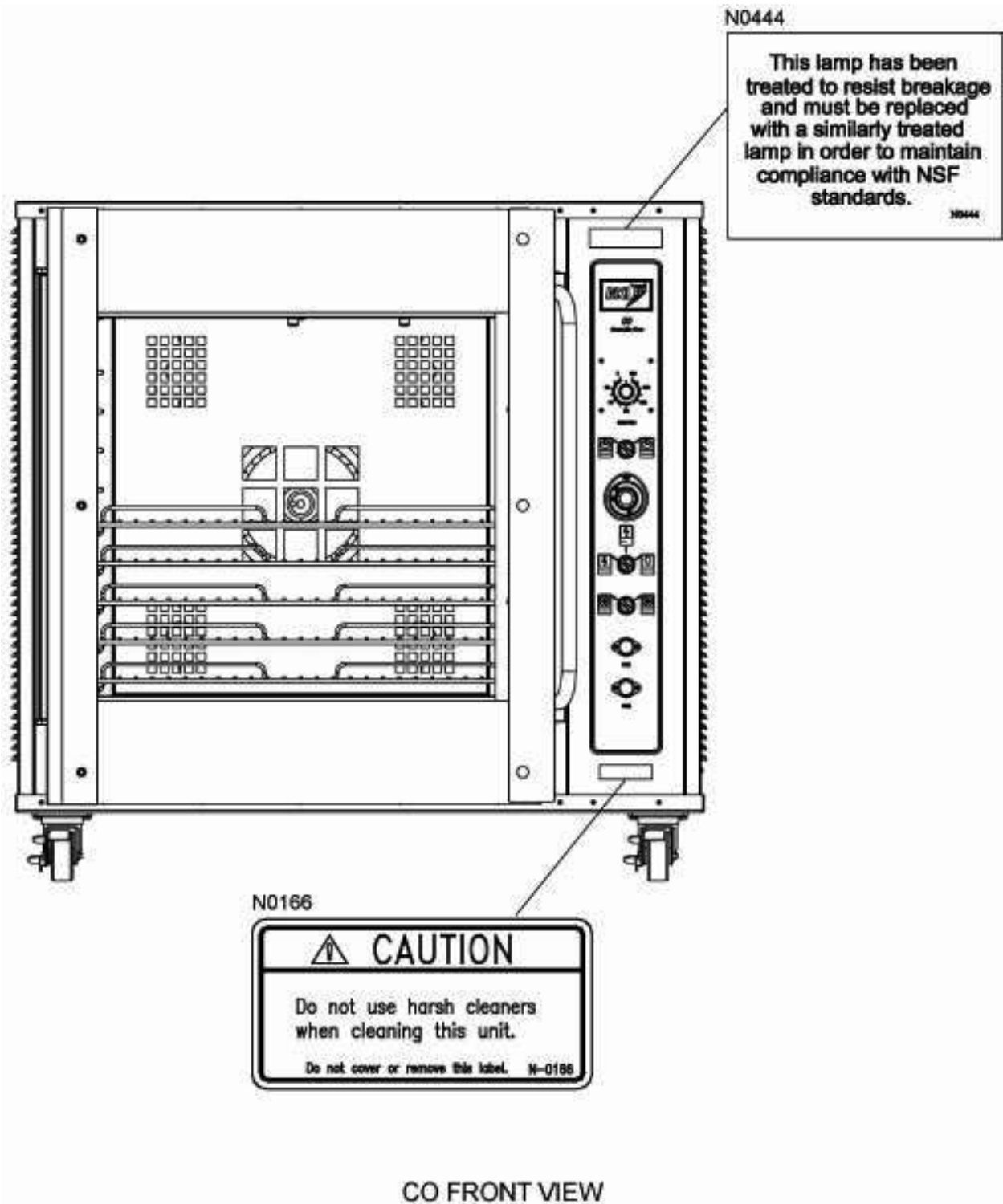

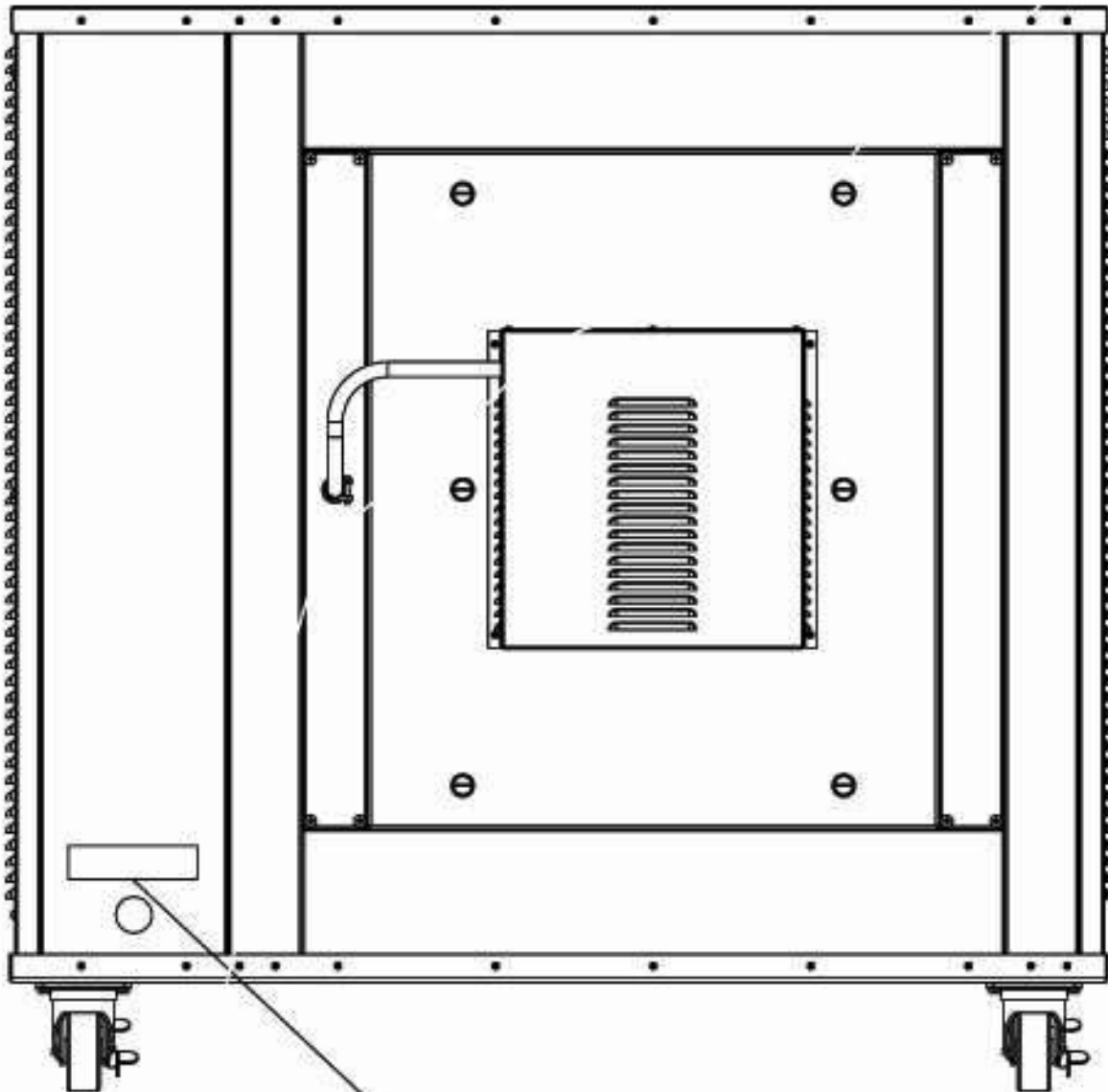

N0202



CO BACK VIEW

Health And Sanitation Practices

BKI ovens are manufactured to comply with health regulations and are tested and certified to UL[®], CUL[®], and NSF[®] standards. You must operate the equipment properly using only quality products and use meat thermometers to insure meats are thoroughly cooked.

Food Handling

- Wash hands thoroughly in warm, soapy water after handling raw poultry or meats.
- Clean and sanitize all utensils and surfaces that have been in contact with raw products.
- **Never** place cooked meats on the same surfaces used to prepare raw meats, unless the area has been thoroughly cleaned and sanitized.

Storage Of Raw Meats

- Designate an area or shelf strictly for the storage of all raw meats to be used in the oven.
- Raw product must always be stored at temperatures below 38° F. (3° C.).
- **Never** store or mix raw foods above cooked foods, as this is a health hazard. The drippings from raw foods contaminate cooked or processed foods.
- All chicken and chicken parts to be stored overnight must be thoroughly iced down and refrigerated.

Coding Cooked Foods

All products cooked during the day should be sold the same day.

NOTE: It is not the intent of the cooking program to have unsold merchandise at the end of the cooking day. Follow your company's procedures for the handling of any leftover product.

Storage Of Prepared Foods

- Cold foods should be kept at or below 38° F. (3° C.).
- Hot foods must be maintained to meet local health codes, usually a minimum 145° F. (63° C.).

Installation



WARNING

Serious injury, equipment damage or death could result if attempting to install this oven yourself. Ensure that an authorized BKI service agent install the oven.

Unpacking and Handling

It is the owners' responsibility to file all freight claims with the delivering truck line. Inspect all cartons and crates for damage as soon as they arrive. If damage to cartons or crates is found, or if a shortage is found, note this on the bill of lading (all copies) prior to signing.

If damage is found when the equipment is opened, immediately call the delivering truck line and follow up the call with a written report indicating concealed damage to your shipment. Ask for an immediate inspection of your concealed damage item. Packaging material **MUST** be retained to show the inspector from the truck line.

Remove all packing from the interior and exterior of the oven.

Location and Clearance

1. Place the oven not less than 8" from the back wall.
2. Lock the casters so the oven does not move. After every time the oven is moved, make sure the casters are locked.

Wiring



WARNING

Electrocution, equipment failure or property damage could result if an unlicensed electrician performs the electrical installation. Ensure that a licensed electrician perform the electrical installation in accordance with local codes, or in the absence of local codes, with the National Electrical Code, ANSI NFPA 70-20XX.

This unit, when installed by an authorized BKI service agent, must be wired for use in accordance with all applicable local, state, and federal codes. For specific electrical requirements and connections refer to the wiring diagram attached to the unit or provided in the Service Manual.

Replacement Parts

Use the information in this section to identify replacement parts. To order replacement parts, call your local BKI sales and service representative. Before calling, please note the serial number on the rating tag affixed to the unit.

Assemblies

Description	Assembly #	Figure #	Table #
Inner Door Assembly	AB30103000	Figure 1	Table 1
Outer Door Assembly	AB30104200	Figure 2	Table 2
Control Panel Assembly	AN30102900	Figure 3	Table 3
Blower Mounting Assembly	SB0306	Figure 4	Table 4
Caster Base Assembly	AN30102600	Figure 5	Table 5

Figure 1. Inner Door Assembly

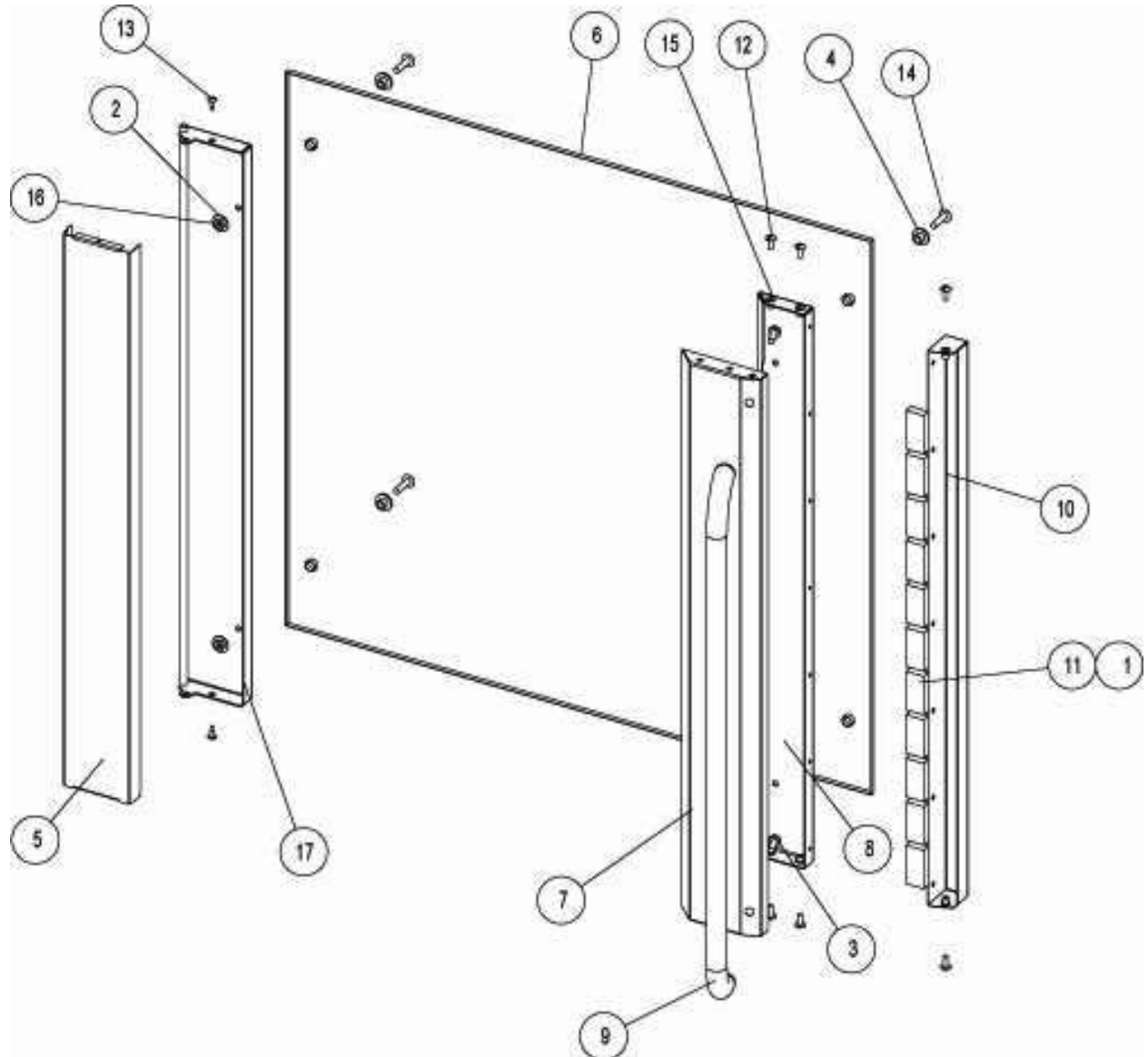

Table 1. Inner Door Assembly Parts

ITEM #	PART #	QTY	DESCRIPTION
1	TP0037	1	TAPE, 7/8 DBL SIDE 3M6381 WHITE
2	WSH038	4	WASHER, 1/4 USS FLAT
3	SCR059	2	SCREW, 1/4-20 X 3/4 HEX CAP
4	B0858	4	BUSHING, INNER DOOR GLASS VG
5	FB45419051	1	COVER, HINGE INNER DOOR VG
6	GL0298	1	GLASS, 27.06 X 28.656 VG
7	FB45442451	1	HANDLE BRKT COVER VG14
8	FB45442302	1	HANDLE BRKT VG14
9	H0209	1	HANDLE, VG COMPONENT HDWE
10	FB30102003	1	MAGNET MOUNT, INNER DOOR CO
11	MC0005	11	MAGNET, 1 7/8 X 7/8
12	SCR439	6	SCREW, 8-32 X 1/2 PHIL TR HD
13	SCR005	2	SCREW, 8 X 1/2 PHIL TRUSS HD
14	SCR418	4	SCREW, 1/4-20 X 1 SLTD TR HD
15	F0137	6	THREAD INSERT 8-32 STEEL
16	WSH248	4	WASHERED LOCKNUT, 1/4-20 ZINC
17	WB45418900	1	HINGE, INNER DOOR WELDMENT VG

Figure 2. Outer Door Assembly

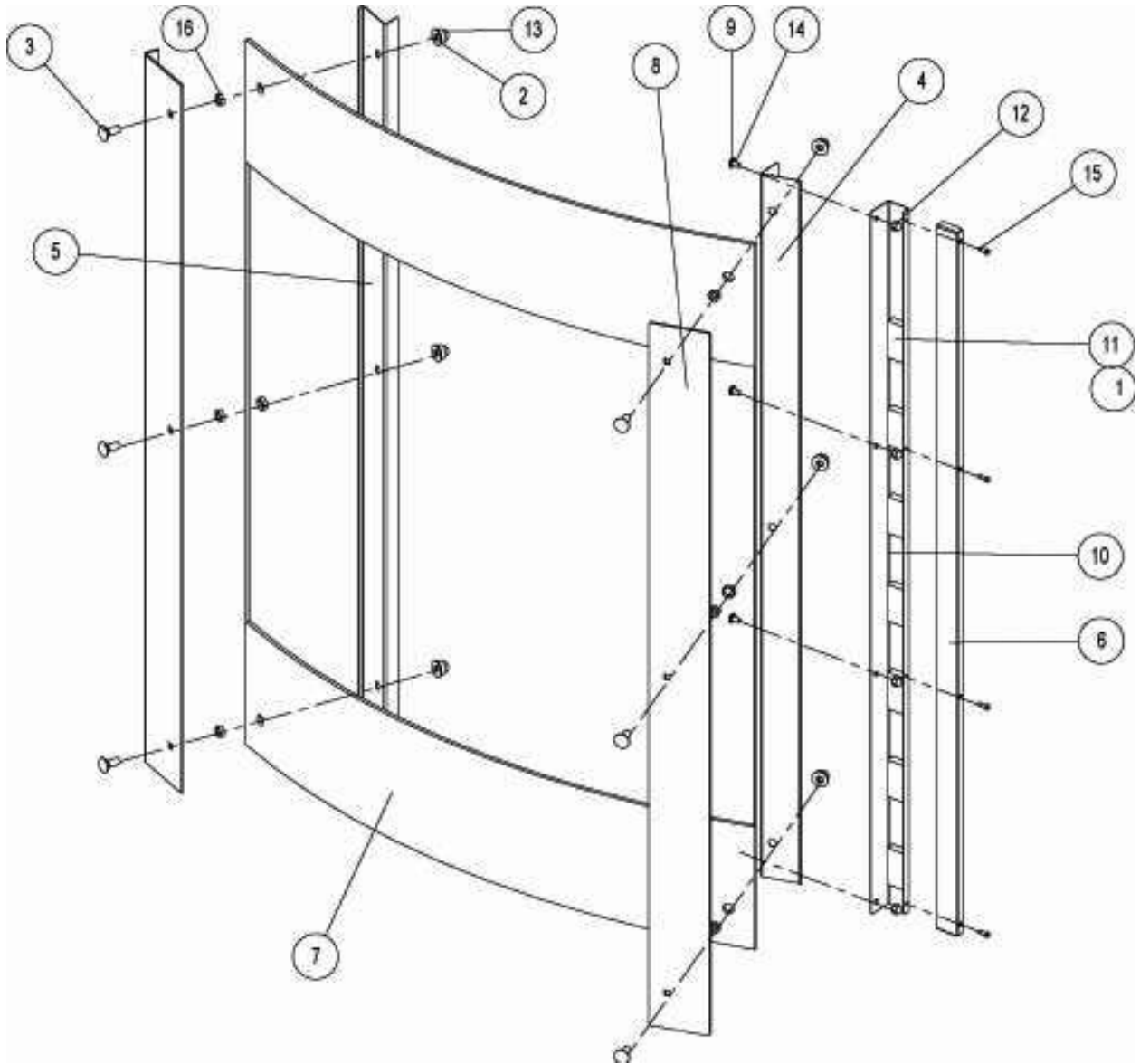

Table 2. Outer Door Assembly Parts

ITEM #	PART #	QTY	DESCRIPTION
1	TP0037	1	TAPE, 7/8 DBL SIDE 3M6381 WHITE
2	WSH038	6	WASHER, 1/4 USS FLAT
3	BLT257	6	BOLT, 1/4-20 X 5/8 CARRIAGE
4	FB45443303	1	BUMPER BRKT OUTER DOOR VG14
5	FB45443403	1	BUMPER BRKT OUTER DOOR VG14
6	FB45443503	1	COVER, MAGNET VG
7	GL0300M	1	GLASS, VG OUTER DOOR W/MATRIX
8	FB45443203	1	DOOR LATCH PLATE OUTER DOOR
9	WSH246	8	WASHER, #10 INT TOOTH S/S
10	FB45455703	1	MAGNET MOUNT, OUTER DOOR VG
11	MC0005	7	MAGNET, 1 7/8 X 7/8
12	NUT132	4	NUT, 10-24 SS 18-8 HEX CAP
13	NUT097	6	NUT, 1/4-20 SS 18-8 CAP
14	SCR434	4	SCREW, 10-24 X 3/8 PHIL TR HD
15	SCR006	4	SCREW, 8 X 1/2 PHIL PAN HEAD
16	SP0031	6	SPACER, PTFE-DOOR GLASS
17	WB30104100	1	HINGE OPER SIDE OUT.DOOR WELD CO

Figure 3. Control Panel Assembly

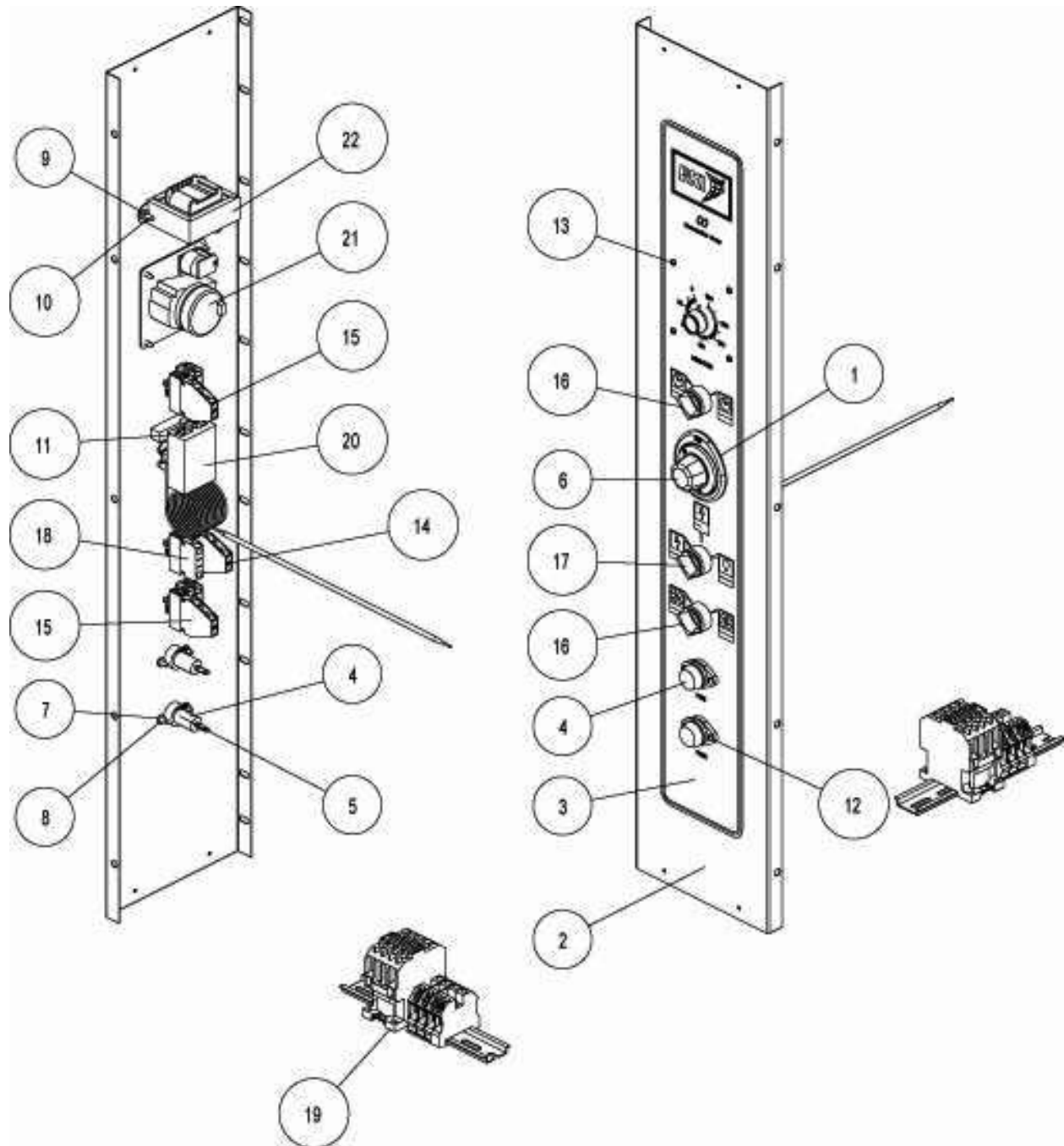

Table 3. Control Panel Assembly Parts

ITEM #	PART #	QTY	DESCRIPTION
1	B1050	1	BEZEL, ROBERTSHAW THERMOSTAT
2	FB30101603	1	CONTROL PANEL, FRONT CO
3	N0530	1	DECAL, CONTROL PANEL CO
4	FH0001	2	FUSE HOLDER, 15A 300V HPF-EE
5	F0097	2	FUSE, 15A 300V SC15 TIME DELAY
6	K0028	1	KNOB, T-STAT BLK 450DEG
7	WSH089	4	WASHER, #6 INT LOCK ZINC PLATED
8	NUT048	4	NUT, 6-32 HEX ZINC PLTD
9	NUT276	2	NUT, 8-32 WASHERED LOCKNUT
10	SCR425	2	SCREW, STUD 8-32 X 1/2 WELD
11	SCR117	2	SCREW, 6-32 X 3/8 PHIL RD HD
12	SCR118	4	SCREW, 6-32 X 5/8 SLTD RD HD
13	SCR006	4	SCREW, 8 X 1/2 PHIL PAN HEAD
14	S0347	1	SWITCH, CONTACT BLOCK 2NC
15	S0339	2	SWITCH, CONTACT BLOCK 2 NO
16	S0304	2	SWITCH, 2 POS OPERATOR BLK
17	S0338	1	SWITCH, 3 POS SATIN CHROME
18	S0307	1	SWITCH, NO BLOCK GE P9B10VN
19	AB30103100	1	TERM BLK/RELAY MNT RAIL ASSY CO
20	T0005	1	THERMOSTAT, 115-277V 450 DEG SGLPOLE
21	TI0009	1	TIMER, 3 HR
22	TF0035	1	TRANSFORMER, 230V 50/60HZ TO

Figure 4. Blower Mounting Assembly

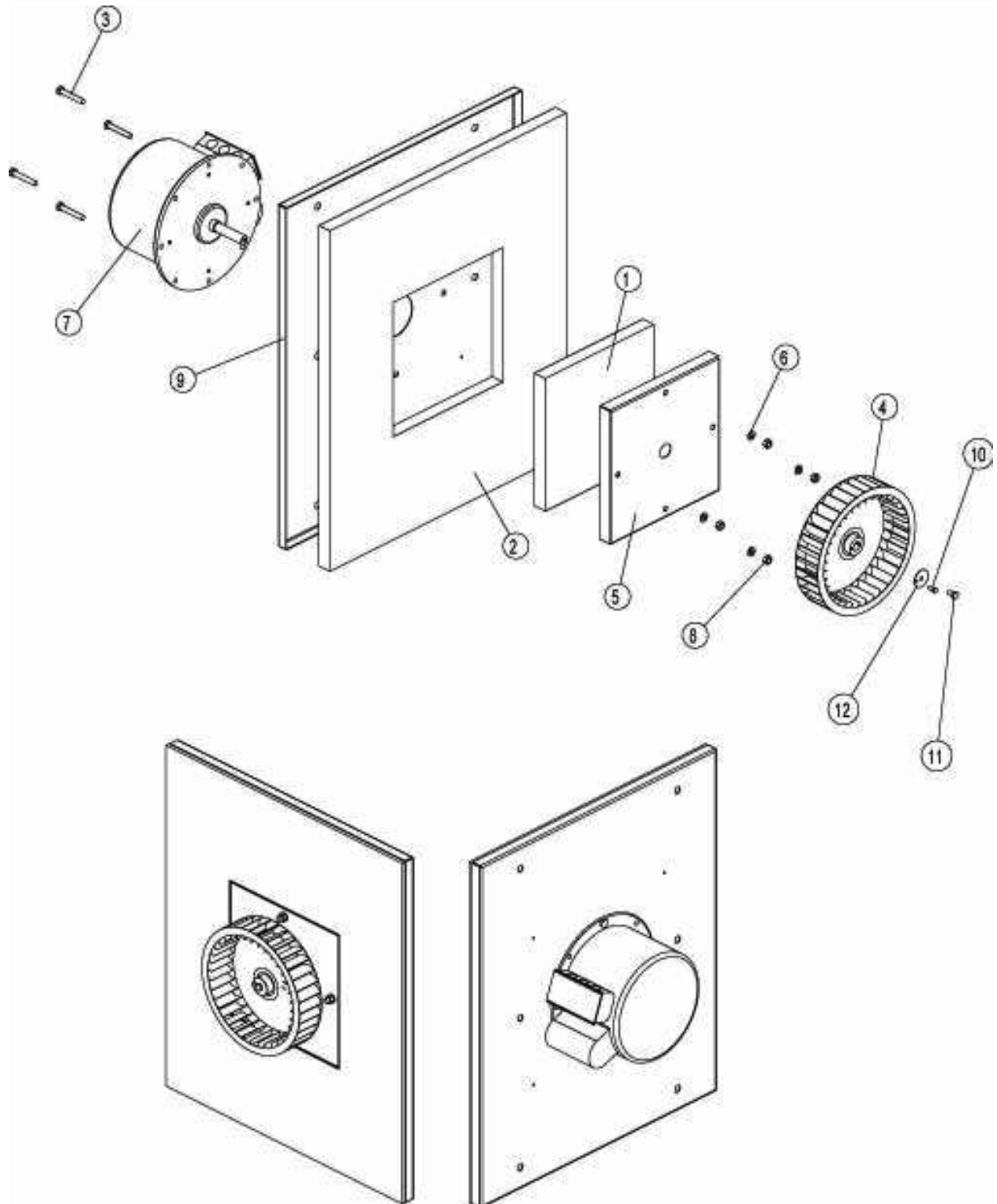

Table 4. Blower Mounting Assembly Parts

ITEM #	PART #	QTY	DESCRIPTION
1	I0005	1	.7 SQ FT INSULATION
2	I0005	1	3.3 SQ FT INSULATION
3	SCR065	4	5/16"-18 x 2" HEX SCREW
4	SRCA067	1	FAN, BLOWER SRC (USES F0099)
5	SRCA045	1	PAN, INSULATION SRC
6	WSH045	4	LOCKWASHER,5/16" SPLIT - ZINC
7	M0032	1	MOTOR, HOWELL FAN 115/230
8	NUT055	4	NUT,5/16-18X1 FINISHED HEX
9	SRCA031	1	PANEL, OUTSIDE MOTOR SRC
10	SCR272	1	SCREW, 10-24 X 1/2 HEX HD MS
11	SCR273	1	SCREW, 1/4-20 X 1/2 HEX HD
12	SRCA069	1	WASHER, BLOWER MOTOR SRC

Figure 5. Caster Base Assembly

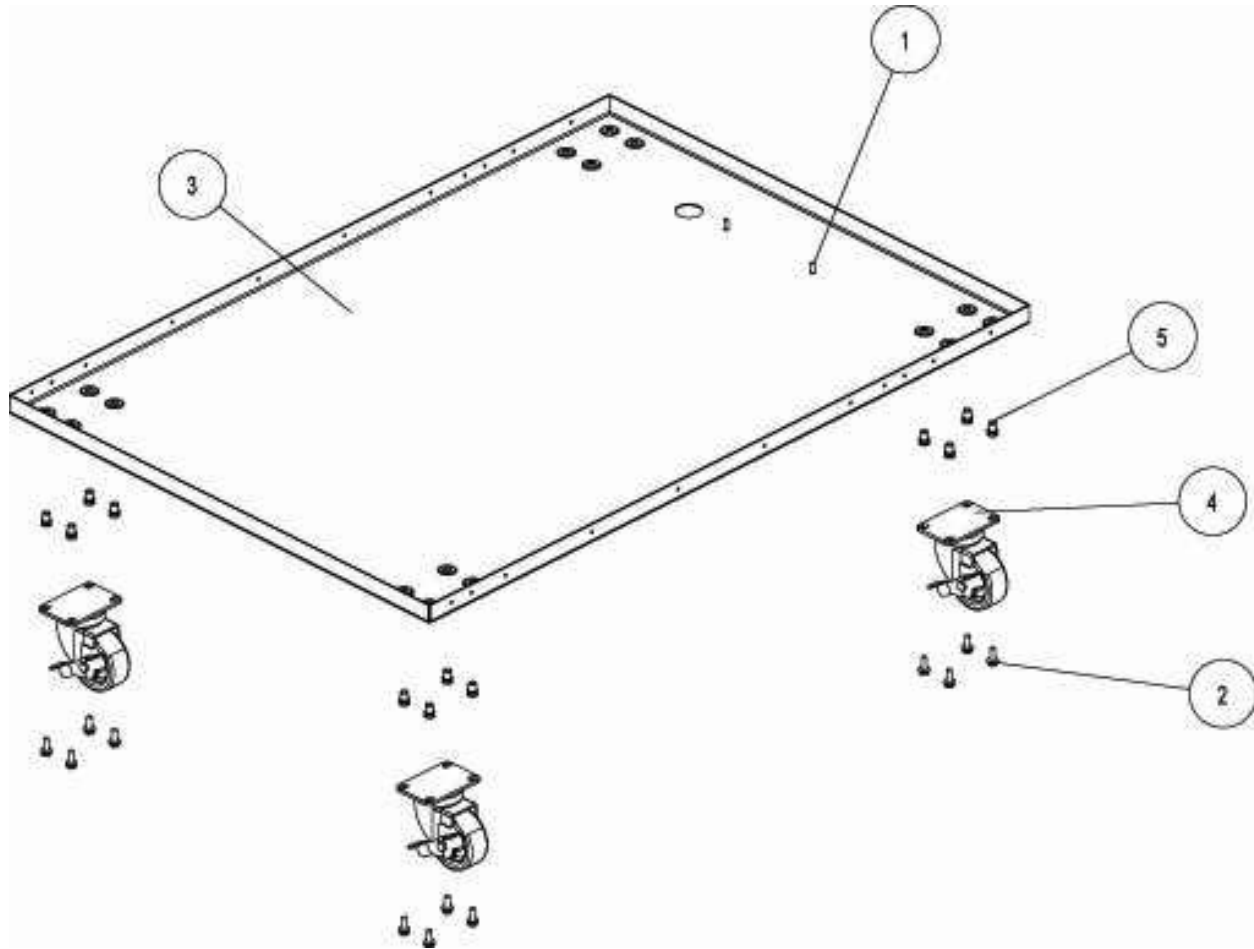

Table 5. Caster Base Assembly Parts

ITEM #	PART #	QTY	DESCRIPTION
1	SCR077	2	SCREW, STUD 10-24 X 1/2 WELD
2	SCR463	16	SCREW, 1/4-20 X 3/4 SERR FLNGD HEX
3	WB30101400	1	BOTTOM OUTSIDE WELDMENT CO
4	C0415	4	CASTER, 3" 3-30-521-2 JARVIS
5	F0140	16	THREAD INSERT 1/4-20 STL HEX

Components

PART #	DESCRIPTION
B0553	BULB, TUFFSKIN 40W 250V
DG0007	GASKET, BULB DOOR SEAL
F0063	CLAMP, SAFETY 16101-S 1/4 DIA
R0029	RACK, 19 1/4 X 25 3/4
S0346	SWITCH, MICRO 15A 125-480VAC
C0026	CALROD, 208V 2000W
C0248	CALROD, 240V 2000W
SB0305B	SIDE INSERT ASSY, ELEC NKL SRC
SR1003	RACK, SIDE TRAY SRC
SRCA086	INSIDE BLOWER CABINET, SRC
WSRCA076	SRC INSIDE BOTT PAN WELD



B0553



DG0007



F0063

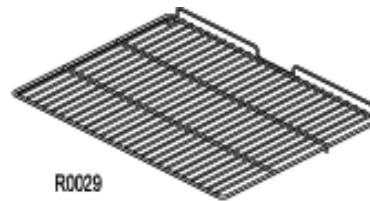

R0029

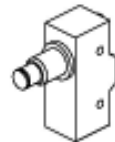

S0346



C0026 - 208V
C0248 - 240V

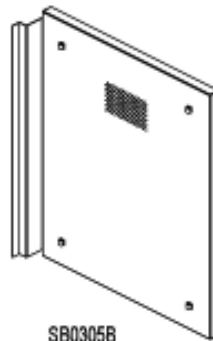

SB0305B



SR1003

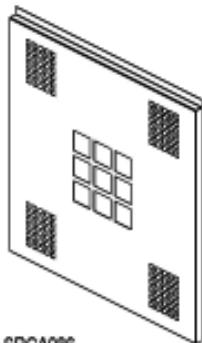

SRCA086

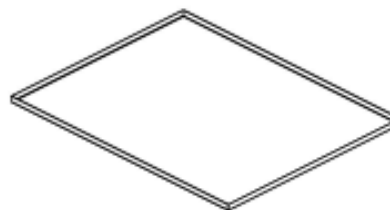

WSRCA076

Wiring Diagrams

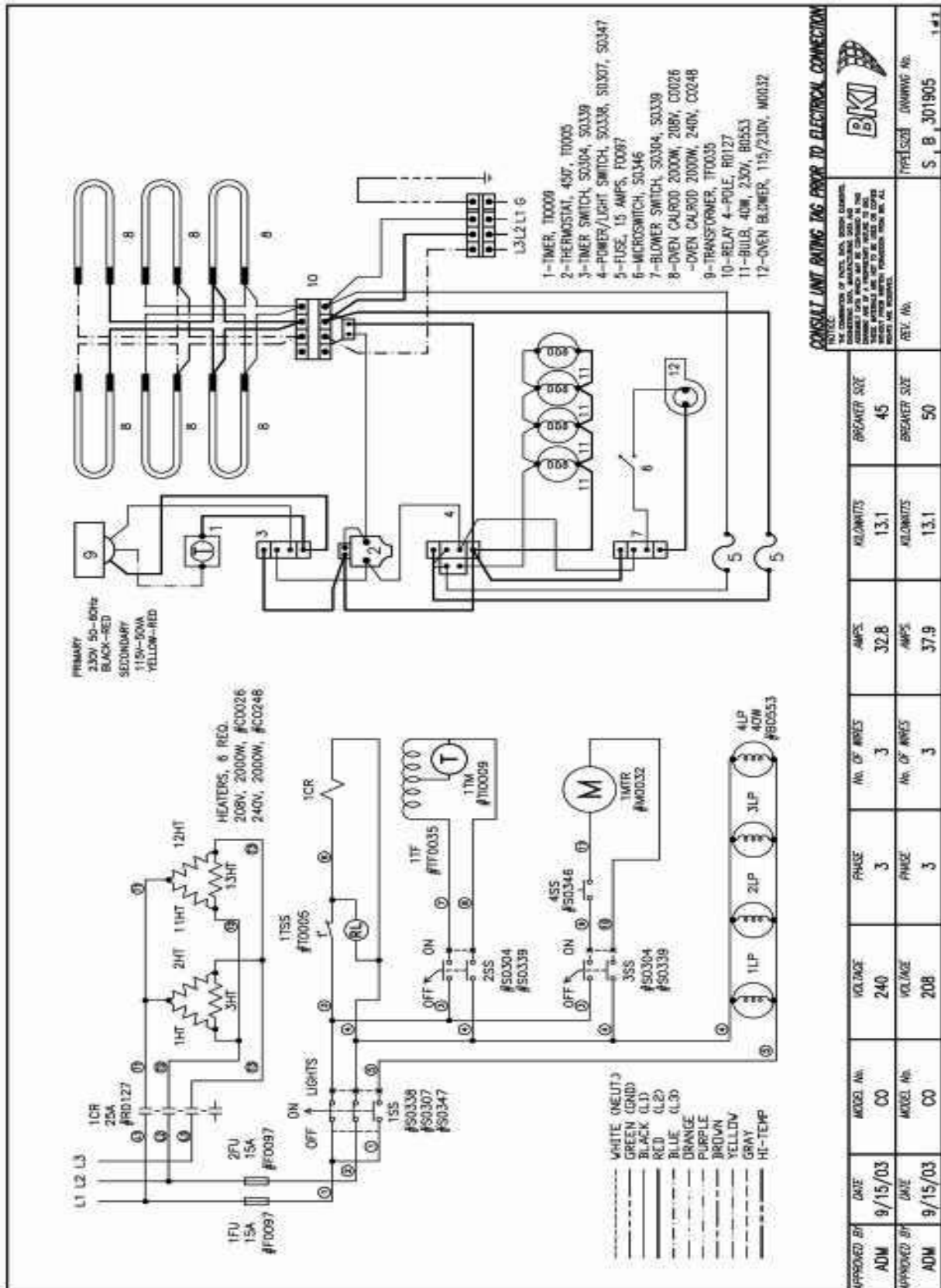

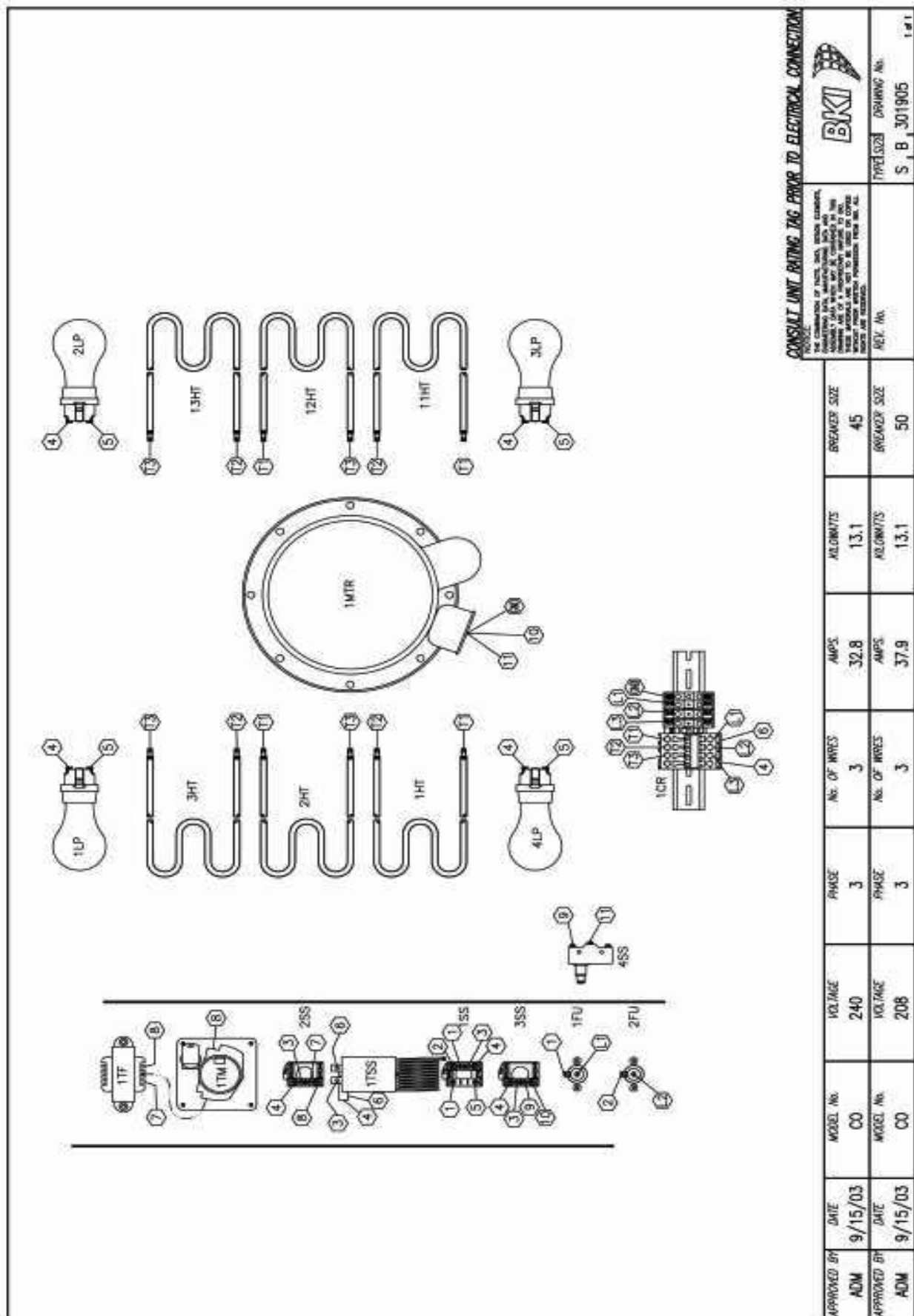

APPROVED BY	DATE	MODEL No.	VOLTAGE	PHASE	NO. OF WIRES	AMPS.	ALLOWITS	BREAKER SIZE
ADM	9/15/03	CO	240	3	3	32.8	13.1	45
APPROVED BY	DATE	MODEL No.	VOLTAGE	PHASE	NO. OF WIRES	AMPS.	ALLOWITS	BREAKER SIZE
ADM	9/15/03	CO	208	3	3	37.9	13.1	50

REV. No. _____
 TYPE/SIZE _____
 DRAWING No. S_B_301905
 1 of 1

NOTES



2812 Grandview Dr., Simpsonville, S.C. 29680, USA
<http://www.bkideas.com>

Made and printed in the U.S.A
LI0217/0407

CS-TM-019.01

Revised 03/22/13

REVISION HISTORY

<u>REVISION</u>	<u>DATE</u>	<u>REVISED BY</u>	<u>DESCRIPTION</u>
01	03/22/13	KW	Initial Release-Supersedes all previous releases