

Gourmet Oven

MODEL GO-36, GO-36T

Service Manual

Serial Numbers 122192 and higher



BKI LIMITED WARRANTY
2812 Grandview Dr. • Simpsonville, SC 29680 • USA
(864) 963-3471 • Toll Free: (800) 927-6887 • Fax: (864) 963-5316

WHAT IS COVERED	<p>This warranty covers defects in material and workmanship under normal use, and applies only to the original purchaser providing that:</p> <ul style="list-style-type: none">☐ The equipment has not been accidentally or intentionally damaged, altered or misused;☐ The equipment is properly installed, adjusted, operated and maintained in accordance with national and local codes, and in accordance with the installation and operating instructions provided with this product.☐ The serial number rating plate affixed to the equipment has not been defaced or removed.
WHO IS COVERED	<p>This warranty is extended to the original purchaser and applies only to equipment purchased for use in the U.S.A.</p>
COVERAGE PERIOD	<ul style="list-style-type: none">☐ Warranty claims must be received in writing by BKI within one (1) year from date of installation or within one (1) year and three (3) months from data of shipment from the factory, whichever comes first.☐ COB Models: One (1) Year limited parts and labor.☐ COM Models: Two (2) Year limited parts and labor. COM convection ovens also have a two (2) year door warranty.☐ CO1 Models: Two (2) Year limited parts and labor. Five (5) Year limited door warranty.☐ BevLes Products: Two (2) Year limited parts and labor.☐ Warranty period begins the date of dealer invoice to customer or ninety (90) days after shipment date from BKI, whichever comes first.
WARRANTY COVERAGE	<p>This warranty covers on-site labor, parts and reasonable travel time and travel expenses of the authorized service representative up to (100) miles round trip and (2) hours travel time and performed during regular, weekday business hours.</p>
EXCEPTIONS	<p>Any exceptions must be pre-approved in advance and in writing by BKI. The extended door warranty on convection ovens years 3 through 5 is a parts only warranty and does not include labor, travel, mileage or any other charges.</p>
EXCLUSIONS	<ul style="list-style-type: none">☐ Negligence or acts of God,☐ Thermostat calibrations after (30) days from equipment installation date,☐ Air and gas adjustments,☐ Light bulbs,☐ Glass doors and door adjustments,☐ Fuses,☐ Adjustments to burner flames and cleaning of pilot burners,☐ Tightening of screws or fasteners,☐ Failures caused by erratic voltages or gas suppliers,☐ Unauthorized repair by anyone other than a BKI Factory Authorized Service Center,☐ Damage in shipment,☐ Alteration, misuse or improper installation,☐ Thermostats and safety valves with broken capillary tubes,☐ Freight - other than normal UPS charges,☐ Ordinary wear and tear,☐ Failure to follow installation and/or operating instructions,☐ Events beyond control of the company.
INSTALLATION	<p>Leveling, as well as proper installation and check out of all new equipment - per appropriate installation and use materials - is the responsibility of the dealer or installer, not the manufacturer.</p>
REPLACEMENT PARTS	<p>BKI genuine Factory OEM parts receive a (90) day materials warranty effective from the date of installation by a BKI Factory Authorized Service Center.</p>

Table of Contents

Table of Contents	1
Introduction	2
Safety Precautions	2
Safety Signs and Messages	2
Safe Work Practices	3
Safety Decals.....	5
Health And Sanitation Practices	6
Food Handling.....	6
Storage Of Raw Meats	6
Coding Cooked Foods	6
Storage Of Prepared Foods.....	6
Installation	7
Unpacking and Handling	7
GO-36 Stacking Instructions	7
Location and Clearance	8
Wiring	8
Maintenance	9
Scheduled Maintenance.....	9
Oven Cleaning	9
Troubleshooting	16
Replacement Parts	18
Wiring Diagrams	30

Introduction

The **BKI** GO-36 is a cook and hold gourmet oven. It consists of a cooking cabinet, door assembly and control unit. The cooking cabinet contains rack supports that hold 4 racks and 1 drip pan. To seal the oven cavity, a door with a magnetized door latch is provided. The control unit contains heating elements for cooking as well as a time/temperature computer and manual switches for quick setup and operation. It also contains a fan for cooling and a blower for heat circulation.

The **BKI** name and trademark on this unit assures you of the finest in design and engineering -- that it has been built with care and dedication -- using the best materials available. Attention to the operating instructions regarding proper installation, operation, and maintenance will result in long lasting dependability to insure the highest profitable return on your investment.

NOTICE

PLEASE READ THIS ENTIRE MANUAL BEFORE OPERATING THE UNIT. If you have any questions, please contact your BKI Distributor. If they are unable to answer your questions, contact the BKI Technical Service Department, toll free: 1-800-927-6887. Outside the U.S., call 1-864-963-3471.

Safety Precautions

Always follow recommended safety precautions listed in this manual. Below is the safety alert symbol. When you see this symbol on your equipment, be alert to the potential for personal injury or property damage.



Safety Signs and Messages

The following Safety signs and messages are placed in this manual to provide instructions and identify specific areas where potential hazards exist and special precautions should be taken. Know and understand the meaning of these instructions, signs, and messages. Damage to the equipment, death or serious injury to you or other persons may result if these messages are not followed.

⚠ DANGER

This message indicates an imminently hazardous situation, which, if not avoided, will result in death or serious injury.

⚠ WARNING

This message indicates a potentially hazardous situation, which, if not avoided, could result in death or serious injury.

⚠ CAUTION

This message indicates a potentially hazardous situation, which, if not avoided, may result in minor or moderate injury. It may also be used to alert against unsafe practices.

NOTICE

This message is used when special information, instructions or identification are required relating to procedures, equipment, tools, capacities and other special data.

Safe Work Practices

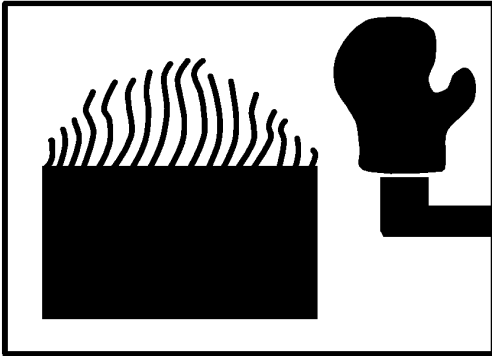

Wear Safe Clothing Appropriate To Your Job

Always wear your insulated mitts when handling hot racks or touch any hot metal surface. If you lose or damage your mitts, you can buy new ones at your local restaurant equipment supply store or from your local BKI Distributor.

Never wear loose clothing such as neckties or scarves while operating this equipment. Keep loose hair tied back or in a hair net while operating this equipment.

Always wear appropriate personal protection equipment during the cleaning process to guard against possible injury from hot cleaning solution.

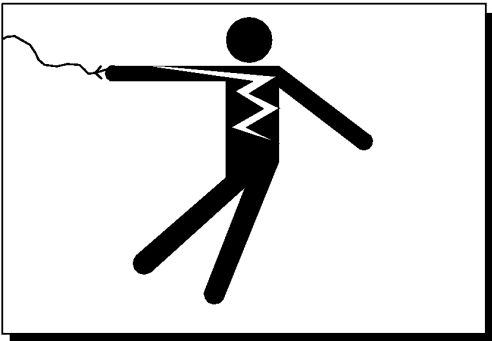

Beware of High Voltage

This equipment uses high voltage. Serious injury can occur if you or any untrained or unauthorized person installs, services, or repairs this equipment. Always use an Authorized Service agent to service your equipment.

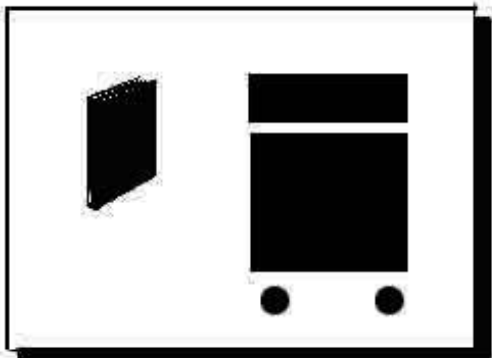

Keep this manual with the Equipment

This manual is an important part of your equipment. Always keep it near for easy access.

If you need to replace this manual, contact:

BKI
 Technical Services Department
 2812 Grandview Drive
 Simpsonville, S.C. 29680
 Or call toll free: 1-800-927-6887
 Outside the U.S., call 864-963-3471



Protect Children

Keep children away from this equipment. Children may not understand that this equipment is dangerous for them and others.

NEVER allow children to play near or operate your equipment.

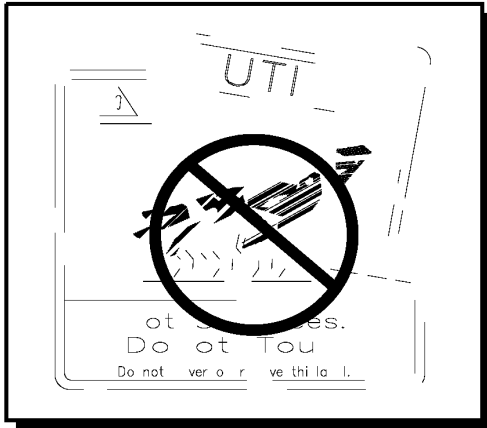

Keep Safety Labels Clean and in Good Condition

Do not remove or cover any safety labels on your equipment. Keep all safety labels clean and in good condition. Replace any damaged or missing safety labels. Refer to the Safety Labels section for illustration and location of safety labels on this unit.

If you need a new safety label, obtain the number of the specific label illustrated on page 5, then contact:

BKI
 Technical Services Department
 2812 Grandview Drive
 Simpsonville, S.C. 29680
 Or call toll free: 1-800-927-6887
 Outside the U.S., call 864-963-3471

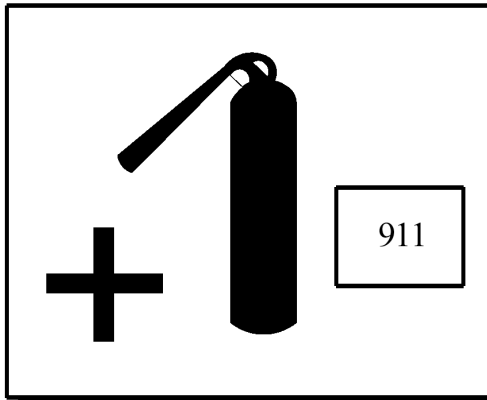

Be Prepared for Emergencies

Be prepared for fires, injuries, or other emergencies.

Keep a first aid kit and a fire extinguisher near the equipment. You must use a 40-pound Type BC fire extinguisher and keep it within 25 feet of your equipment.

Keep emergency numbers for doctors, ambulance services, hospitals, and the fire department near your telephone.

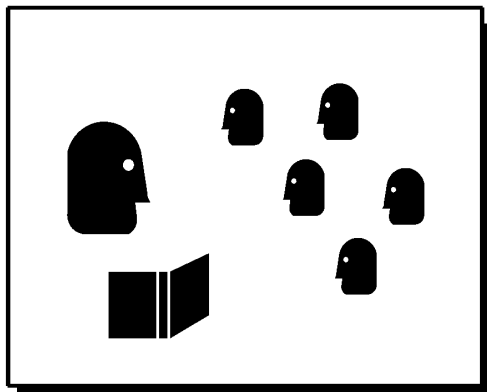

Know your responsibilities as an Employer

- Make certain your employees know how to operate the equipment.
- Make certain your employees are aware of the safety precautions on the equipment and in this manual.
- Make certain that you have thoroughly trained your employees about operating the equipment safely.
- Make certain the equipment is in proper working condition. If you make unauthorized modifications to the equipment, you will reduce the function and safety of the equipment.

Safety Decals

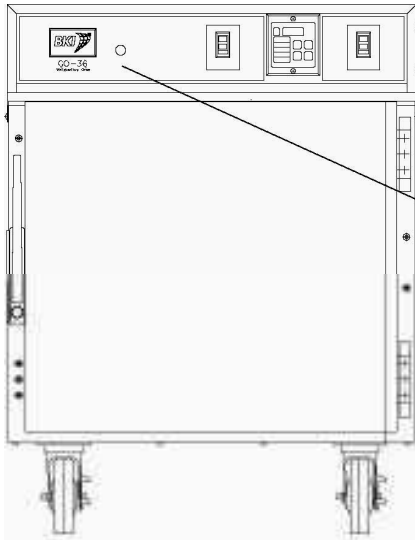

N0536

! WARNING

WHEN LIT UNIT IS MALFUNCTIONING. TURN OFF and CALL FOR SERVICE.

N0536

CAUTION

DISCONNECT FROM POWER SUPPLY BEFORE SERVICING.

FUSE: 250V, 2A, DUAL ELEMENT, TIME DELAY
BUSSMAN TYPE FNM 2

WARNING

FOR CONTINUED PROTECTION AGAINST FIRE AND ELECTRIC SHOCK, REPLACE WITH SAME TYPE AND RATING OF FUSE.

N0539

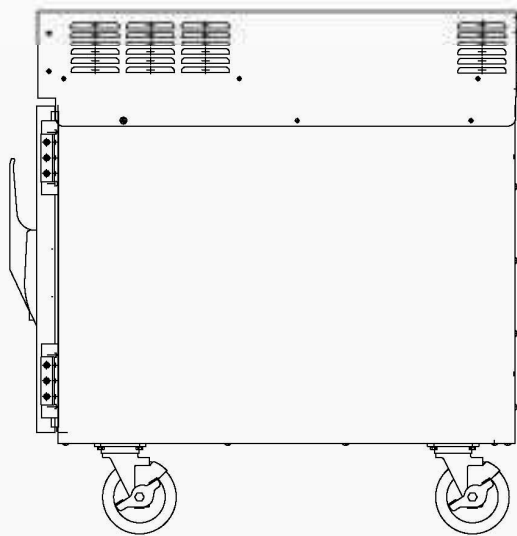

N0202

! DANGER

HIGH VOLTAGE. Turn power off before servicing. May have more than one disconnect switch.

Do not cover or remove label. N0202

N0158

<p>! WARNING</p> <p>CONNECT ONLY TO APPROVED 3 PRONG GROUNDED CIRCUIT. FAILURE TO DO SO COULD RESULT IN SERIOUS INJURY.</p>	<p>! WARNING</p> <p>CONNECT ONLY TO APPROVED 3 PRONG GROUNDED CIRCUIT. FAILURE TO DO SO COULD RESULT IN SERIOUS INJURY.</p>
DO NOT COVER OR REMOVE THIS LABEL	
N0158	

Health And Sanitation Practices

BKI ovens are manufactured to comply with health regulations and are tested and certified to UL[®], CUL[®], and NSF[®] standards. You must operate the equipment properly using only quality products and use meat thermometers to insure meats are thoroughly cooked.

Food Handling

- Wash hands thoroughly in warm, soapy water after handling raw poultry or meats.
- Clean and sanitize all utensils and surfaces that have been in contact with raw products.
- **Never** place cooked meats on the same surfaces used to prepare raw meats, unless the area has been thoroughly cleaned and sanitized.

Storage Of Raw Meats

- Designate an area or shelf strictly for the storage of all raw meats to be used in the oven.
- Raw product must always be stored at temperatures below 38° F. (3° C.).
- **Never** store or mix raw foods above cooked foods, as this is a health hazard. The drippings from raw foods contaminate cooked or processed foods.
- All chicken and chicken parts to be stored overnight must be thoroughly iced down and refrigerated.

Coding Cooked Foods

All products cooked during the day should be sold the same day.

NOTE: It is not the intent of the cooking program to have unsold merchandise at the end of the cooking day. Follow your company's procedures for the handling of any leftover product.

Storage Of Prepared Foods

- Cold foods should be kept at or below 38° F. (3° C.).
- Hot foods must be maintained to meet local health codes, usually a minimum 145° F. (63° C.).

Installation

**WARNING**

Serious injury, equipment damage or death could result if attempting to install this oven. Ensure that an authorized BKI service agent install the oven.

Unpacking and Handling

It is the owners' responsibility to file all freight claims with the delivering truck line. Inspect all cartons and crates for damage as soon as they arrive. If damage to cartons or crates is found, or if a shortage is found, note this on the bill of lading (all copies) prior to signing.

If damage is found when the equipment is opened, immediately call the delivering truck line and follow up the call with a written report indicating concealed damage to your shipment. Ask for an immediate inspection of your concealed damage item. Packaging material **MUST** be retained to show the inspector from the truck line.

Remove all packing from the interior and exterior of the oven.

GO-36 Stacking Instructions

Tools Required: 7/16 combination wrench
 7/16 socket and ratchet
 (2) 2x4x30" pieces of wood

NOTE: Remove all plastic from stacking kit parts.

1. Remove racks and drip pans from inside both ovens.
2. Place two wood 2x4x30" pieces on the floor. Tilt unit back onto wood pieces being careful not to crush fuse holders or power cord.
3. Remove casters and place large aluminum base WB56210600 (lip goes downward) between the bottom of the oven and the casters. Install the caster hardware that was removed.
4. Carefully place unit upright.
5. Remove the heater control unit of the base unit (3 screws on each side). Place four (4) small stainless steel angles (FA56210702) at the outside corners of the gasket on the oven cabinet. Replace heater control unit.
6. Carefully place second unit on its back just as in step 2.
7. Remove casters and store. Place stacking kit piece AB56210500 (with louvers on sides) with notches toward the oven back. Install hardware removed from the casters to secure the stacking kit piece to the oven bottom. Install four (4) handles on sides of stacking kit piece using 1/4-20 x 1" bolts and lockwashers.

NOTE: Be sure handles are secure.

8. Place unit upright.

NOTE: Lock the casters on the bottom unit.



CAUTION Be careful not to pinch hands while installing the top unit.

9. Carefully lift the oven with the handles and place on top of other oven.
10. Seal the base and the stacking kit piece to the oven bottoms using silicone rubber RTV (S0018) approved for this use.
11. Replace racks and drip pans.

Location and Clearance

Allow enough air space around the unit to provide for proper ventilation.

Wiring



Electrocution, equipment failure or property damage could result if an unlicensed electrician performs the electrical installation. Ensure that a licensed electrician perform the electrical installation.

The oven, when installed by an authorized BKI service agent, must be grounded in accordance with local codes, or in the absence of local codes, with the National Electrical Code, ANSI NFPA 70-2002. You can obtain this code from:

The National Fire Protection Association
Batterymarch Park
Quincy, MA 02269

Maintenance

⚠ CAUTION

Failure to comply with the maintenance below could result in a serious accident or equipment damage.

⚠ DANGER

Failure to remove power from this unit before performing maintenance may cause severe electrical shock. This unit may have more than one disconnect switch.

Scheduled Maintenance

Oven Cleaning

The oven must be cleaned at the end of each business day. It is easier to clean while still warm. Cleaning is not only necessary for sanitary reasons, but will increase sales appeal and maximize operating efficiency.

⚠ DANGER

Failure to remove power from this unit may cause severe electrical shock. This unit may have more than one disconnect switch.

⚠ CAUTION

Using abrasive cleaners may damage the cabinet finish. Use only a mild soap and water solution.

Never steam clean or get excess water in the interior of the cabinet as this can damage unit.

DO NOT USE OVEN CLEANER on this machine. Caustic cleaners can cause damage to the machine.

Always wear appropriate personal protection equipment during the cleaning process to guard against possible injury from hot cleaning solution.

1. Place the POWER ON/POWER OFF rocker switch in the POWER OFF position and unplug the power cord.
2. Wearing your insulated mitts, remove all food pans from the unit.
3. Let the oven cool to room temperature.
4. Remove racks and drip pan from the unit and place them in a large sink to soak in hot cleaning solution (BKI Cleaner).



5. Remove the rack supports by following the appropriate procedure below:

For GO-36:

- a. Lift the left-side rack support up and off of its mounting studs.



- b. Once the rack support is off of its studs, tilt the top toward the center of the oven.



- c. Pull rack support out of oven and clean.



- d. Repeat these steps for the right-side rack support.

For GO-36T:

- a. Lift the left-side rack support with attached baffle up and off of its mounting studs.



- b. Once the rack support is off of its studs, tilt the top toward the center of the oven.



- c. Pull rack support with attached baffle out of oven opening.



- d. Disconnect baffle from rack support and clean both parts.

- e. Repeat these steps for the right-side rack support and baffle.
6. Clean the outside and inside of the oven with warm water, a sponge and approved cleaner which is authorized for use on food surface areas.
7. Wipe the unit dry with a soft cloth.
8. To reinstall rack supports follow the procedures below:

For GO-36:

- a. Insert the left rack support into the oven against the back wall.



- b. Hook the rack support hangers on the corresponding mounting studs.



- c. Repeat these steps for the right side rack support.

For GO-36T:

- a. To install baffle onto rack support, hold the rack side of the support at a 45° angle to a level surface.



- b. Slide baffle into position as shown allowing hooks on baffle to engage rack support.

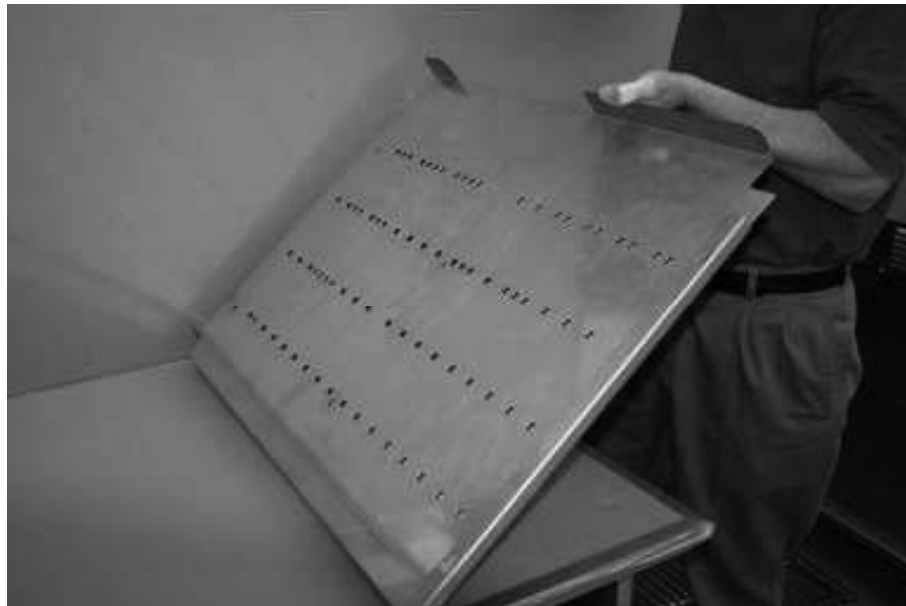

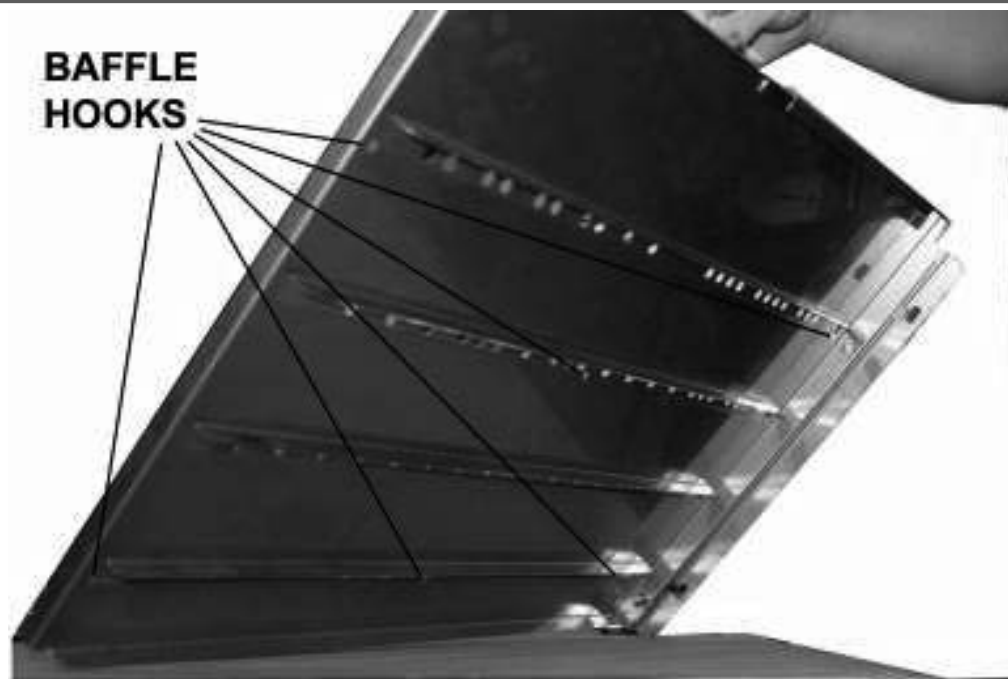

- c. While holding the top of the baffle and the rack support together (keeping hooks from disengaging), tilt top of assembly inward as installing into oven.



- d. While holding the pieces with your hand, upright the assembly and install onto studs in oven. Be careful not to disengage the baffle hooks from the rack support.



- e. Repeat these steps for the right side support.
9. Reinsert the racks and drip pan.

Troubleshooting

Refer to the table below for troubleshooting information.

Problem	Cause	Possible Solution
Unit will not turn on	Oven is not plugged in.	Plug in the oven.
	Power to unit is not on. Problem with building power panel, circuit breaker/fuse or receptacle.	Check circuit breaker or fuses at building power panel.
	Blown fuse on unit.	Contact an authorized BKI service agent for corrective action.
	Defective power switch.	Contact an authorized BKI service agent for corrective action.
	Power supply cord has been damaged.	Contact an authorized BKI service agent for corrective action.
Unit operates for a period of time, then, the control turns off (no display).	Inlet to cooling fan has been blocked, loss of power to cooling fan or defective cooling fan.	Remove blockage from around cooling fan inlet. If problem persists, contact an authorized BKI service agent for corrective action.
	Defective over-temperature switch.	Contact an authorized BKI service agent for corrective action.
	Solid-state relay is defective; causing excessive heat.	Contact an authorized BKI service agent for corrective action.
Oven heats beyond 400° F then drops approximately 50° to 75°, heats, then drops again.	Heater plenum has exceeded allowable temperature limit (450° F). This condition may result from the following: <ul style="list-style-type: none"> • Heat circulation blower not functioning properly. • Failure of solid-state relay. • Failure of surge suppressor (shorted). • Short circuit (to ground) in heater bank. • Controller failure. • Defective thermocouple. 	Contact an authorized BKI service agent for corrective action.
Malfunction Warning Light on Control Unit is illuminated indicating overtemperature condition in the Control Unit Assembly. (For units with indicating light).	Refer to previous 2 problems above.	Place the POWER ON/ POWER OFF switch in the POWER OFF position and contact an authorized BKI service agent for corrective action.
Oven does not heat at all.	Improper control settings.	Reset the control.
	Loose wire on heater circuit.	Contact an authorized BKI service agent for corrective action.

Problem	Cause	Possible Solution
	Defective relay.	Contact an authorized BKI service agent for corrective action.
	Heating elements not functioning.	Contact an authorized BKI service agent for corrective action.
	Oven over-temperature switch defective.	Contact an authorized BKI service agent for corrective action.
Oven has very slow heat up or recovery. NOTE: This is normal when using the LOW POWER setting.	Improper power line voltage.	Contact an authorized BKI service agent for corrective action.
	Heating elements not functioning.	Contact an authorized BKI service agent for corrective action.
	Defective HIGH POWER/LOW POWER switch.	Contact an authorized BKI service agent for corrective action.
Oven will not come up to temperature	Oven HIGH POWER/LOW POWER switch is in the LOW POWER position with the oven control set in the 300°-400° F range.	For these temperatures, operate oven on HIGH POWER.
	One or more heater elements not operating.	Contact an authorized BKI service agent for corrective action.
Control displays "PROB".	Damaged probe.	Contact an authorized BKI service agent for corrective action.
	Thermocouple connection is loose.	Contact an authorized BKI service agent for corrective action.
Control displays "EEEE".	Temperature inside the oven is below 50° F.	Reprogram the controller.
	Time/Temperature controller has failed.	Contact an authorized BKI service agent for corrective action.
Product not cooked thoroughly	Oven not preheated.	Be sure to preheat the oven to 300 degrees before placing product in oven.
	Improper time and temperature.	Check program for proper time and temperature setting.

Replacement Parts

Use the information in this section to identify replacement parts. To order replacement parts, call your local BKI sales and service representative. Before calling, please note the serial number on the rating tag affixed to the unit.

Description	Assembly #	Figure #	Table #
Cabinet Assembly	N/A	Figure 1	Table 1
Control Unit Assembly (GO-36) Control Unit Assembly (ENGLAND, GO-36) Control Unit Assembly (GO-36T)	AB56200400 AN56212300 AB56213000	Figure 2	Table 2
Heated Plenum Assembly (GO-36) Heated Plenum Assembly (GO-36T)	AB56201300 AB56212500	Figure 3 Figure 4	Table 3 Table 4
Door Assembly (GO-36/GO-36T)	WB56201600	Figure 5	Table 5
Stacking Kit Assembly	AN56211200	Figure 6	Table 6

Figure 1. Cabinet Assembly

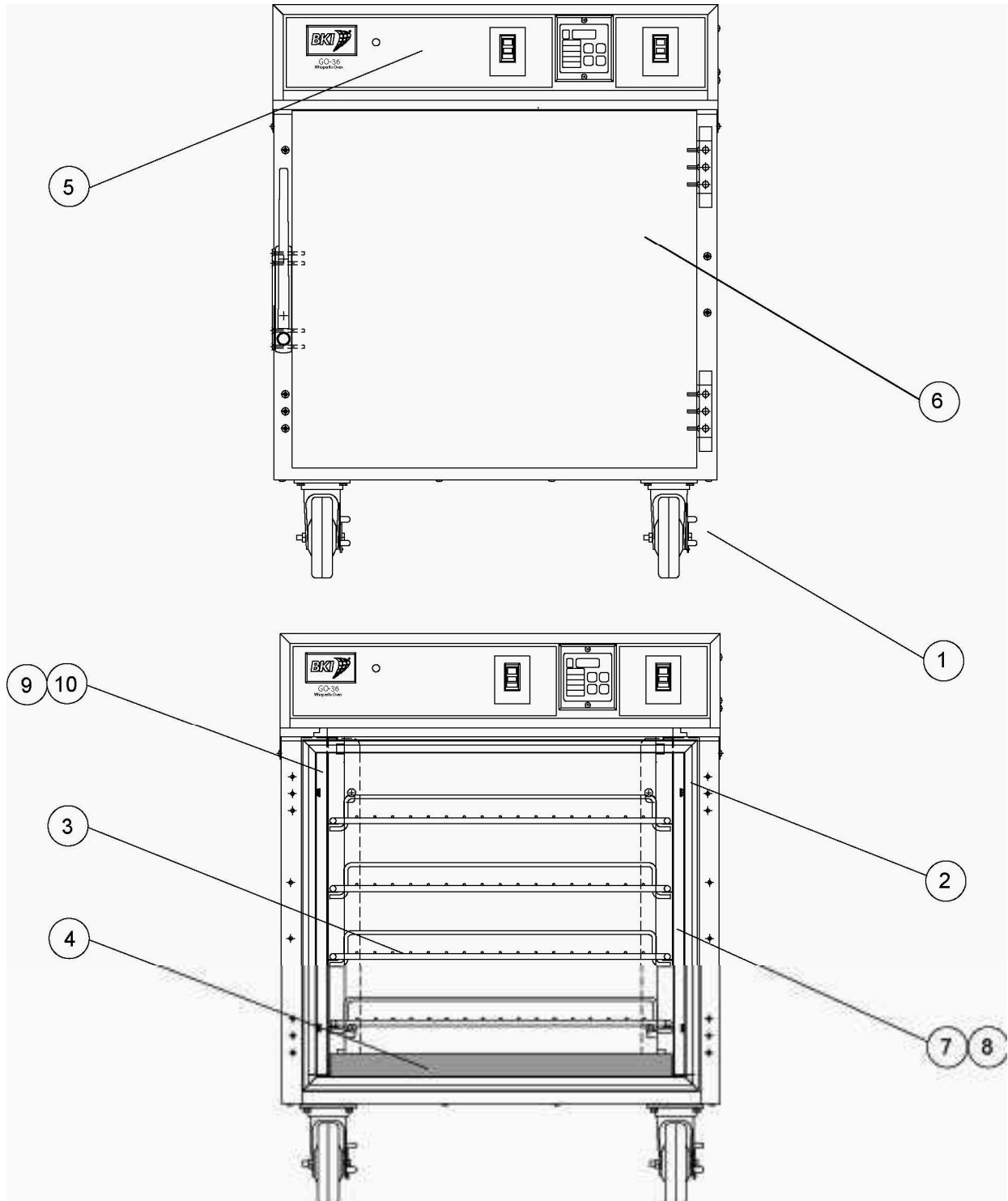

Table 1. Cabinet Assembly Parts

ITEM #	PART #	QTY	DESCRIPTION
1	C0406 <i>or</i> C0415	4	CASTER, W/TOP PLATE 5" <i>or</i> CASTER, 3" 3-30-521-2 JARVIS
2	G0068	1	GASKET, DOOR GO36
3	R0078	4	RACK, 21 3/8 X 28 1/2
4	WB56208300	1	DRIP PAN WELD, GO-36
5	AB56200400 AN56212300 AB56213000	1	CONTROL UNIT
6	AB56211800 WB562016	1	DOOR
7	FB56202502	1	RACK SUPPORT, RIGHT
8	FB56207702	1	BAFFLE, RIGHT RACK SUPPORT (GO-36T)
9	FB56202402	1	RACK SUPPORT, LEFT
10	FB56207602	1	BAFFLE, LEFT RACK SUPPORT (GO-36T)

Figure 2. Control Unit Assembly

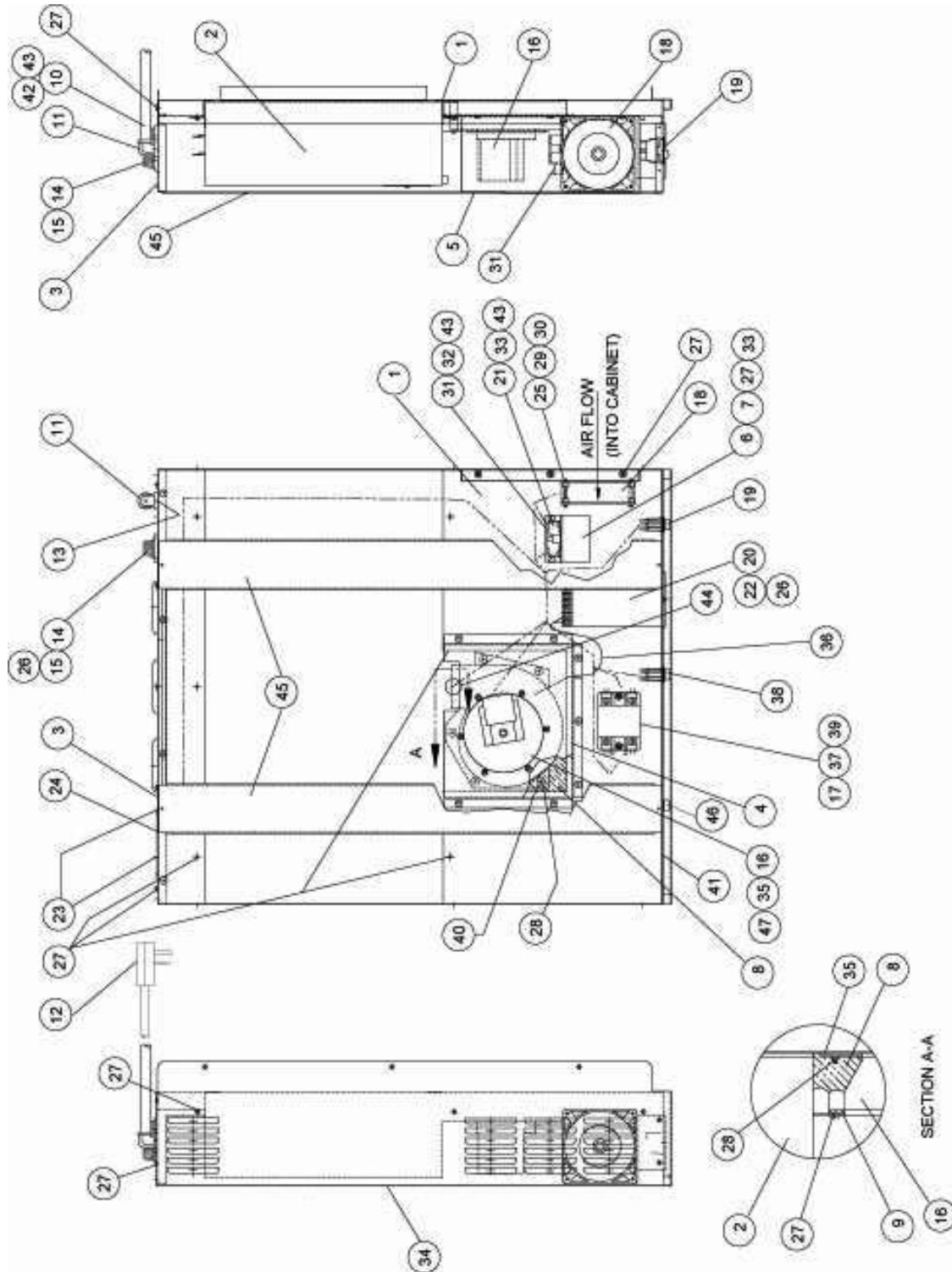

Table 2. Control Unit Assembly Parts

ITEM #	PART #	QTY	DESCRIPTION
1	WB56201000	1	CTRL UNIT BASE WELD, GO-36
2	AB56201300	1	HEATED PLENUM ASSY, GO36
	AB56212500		FOUR HEATER PLENUM ASSY, GO36T

ITEM #	PART #	QTY	DESCRIPTION
3	FB56203303 FB56213103	1	REAR PANEL, CONTROL UNIT (GO36) REAR PANEL, CTRL. UNIT (GO-36T)
4	FB56204202	1	COVER, BLOWER SCROLL INSUL
5	FB56204002	1	MOUNT, FAN C&H
6	MA56206100	1	HEATSINK, SOLID STATE RELAY
7	FA56206802	1	BRACKET, HEAT SINK
8	I0005 I0030	0.5 sq. ft.	INSULATION, 1"TK (GO36) 1" BGF MAT INSULATION (GO36T)
9	TP0026	0.75 ft.	TAPE, SILICONE RUBBER 1" X 1/8
10	CS0023 W0134	1	CORD SET, 250V 6' 12/3 SO (GO36) CORD, 10/3 SOOW, 7' (GO-36T)
11	F0157 F0390	1	CORD GRIP, 90 DEG, 1/2" COND (GO36) CORD GRIP, RT ANG., 3/4"C HUB, .625-.750" (GO-36T)
12	FT0564	1	PLUG, RT ANG., NEMA 6-30 (GO-36T)
13	FT0185/F0067 FT0268	1	LOCKNUT, 1/2"/WASHER, REDUCER #100-50 (GO36) 3/4" CONDUIT LOCKNUT (GO-36T)
14	FH0006	2	FUSE HOLDER, 30A 600V HPF
15	F0108	2	FUSE, 2A 250V FNM-2 TIME DELAY
16	M0095	1	BLOWER MOTOR & HOUSING (HIGH TEMPERATURE)
17	R0136	1	RELAY, 2 POLE, 35A RESISTIVE
18	FN0012	1	FAN, 230V, 50/60 HZ 'BOXER'
19	S0103	1	SWITCH, RKR DPST 15A 250V LAMP
20	CP0015 CP0032	1	TIME/TEMP CONTROLLER (for AB56200400) TIME/TEMP CTRLR CELSIUS (for AN56212300)
21	R0137	1	RELAY, SOLID STATE 90-280V
22	N0274	1	DECAL, GO36/DR34 CONTROLLER
23	RIV173	1	RIVET, SSD44 SSBS POP
24	N0023 N0303	1	NAME & RATING TAG, UL (GO36) NAME & RATING TAG, UL (GO36T)
25	SCR315	4	SCREW, 6-32 X 2 RD HD SLTD
26	SCR006	6	SCREW, 8 X 1/2 PHIL PAN HEAD
27	SCR138	46	SCREW, 10 X 1/2 PHIL TR HD
28	NUT076	5	NUT, 10-24 PALNUTS
29	NUT048	4	NUT, 6-32 HEX ZINC PLTD
30	WSH089	8	WASHER, #6 INT LOCK ZINC PLATED
31	S0112	1	SWITCH, OVERTEMPERATURE
32	SCR219	2	SCREW, 4-40 X 3/8 PHIL PAN HD
33	SCR280	4	SCREW, 8-32 X 3/8 PHIL TRUSS
34	FB56205203	1	COVER, CONTROL UNIT
35	G0088	1	GASKET, BLOWER GASKET GO36
36	WA56208700	1	THERMOCOUPLE WIRE WELD GO36
37	SP0001	2	SPACER, ALUM 3/4 X 1/4
38	S0119	1	SWITCH, ROCKER SPST 250VA 15A
39	SCR007	2	SCREW, 8 X 3/4 PHIL TRUSS HD
40	SCR077	5	SCREW, STUD 10-24 X 1/2 WELD
41	N0359	1	DECAL, CONTROL PANEL GO36
42	F0054	1	LUG, RING TERMINAL
43	F0332	2	WIRE JOINT, RC-55 T&B STAKON
44	WSH251	1	WASHER, 7/32 ID X 1 OD STEEL
45	FB56211309	2	TOP SUPPORT CHANNEL, GO36
46	PL0004	1	PILOT LIGHT, ROUND 250V
47	FN0030 or FN0028	1	FAN BLADE (GO-36T) or FAN BLADE (GO-36)

Figure 3. Heated Plenum Assembly (AB56201300)

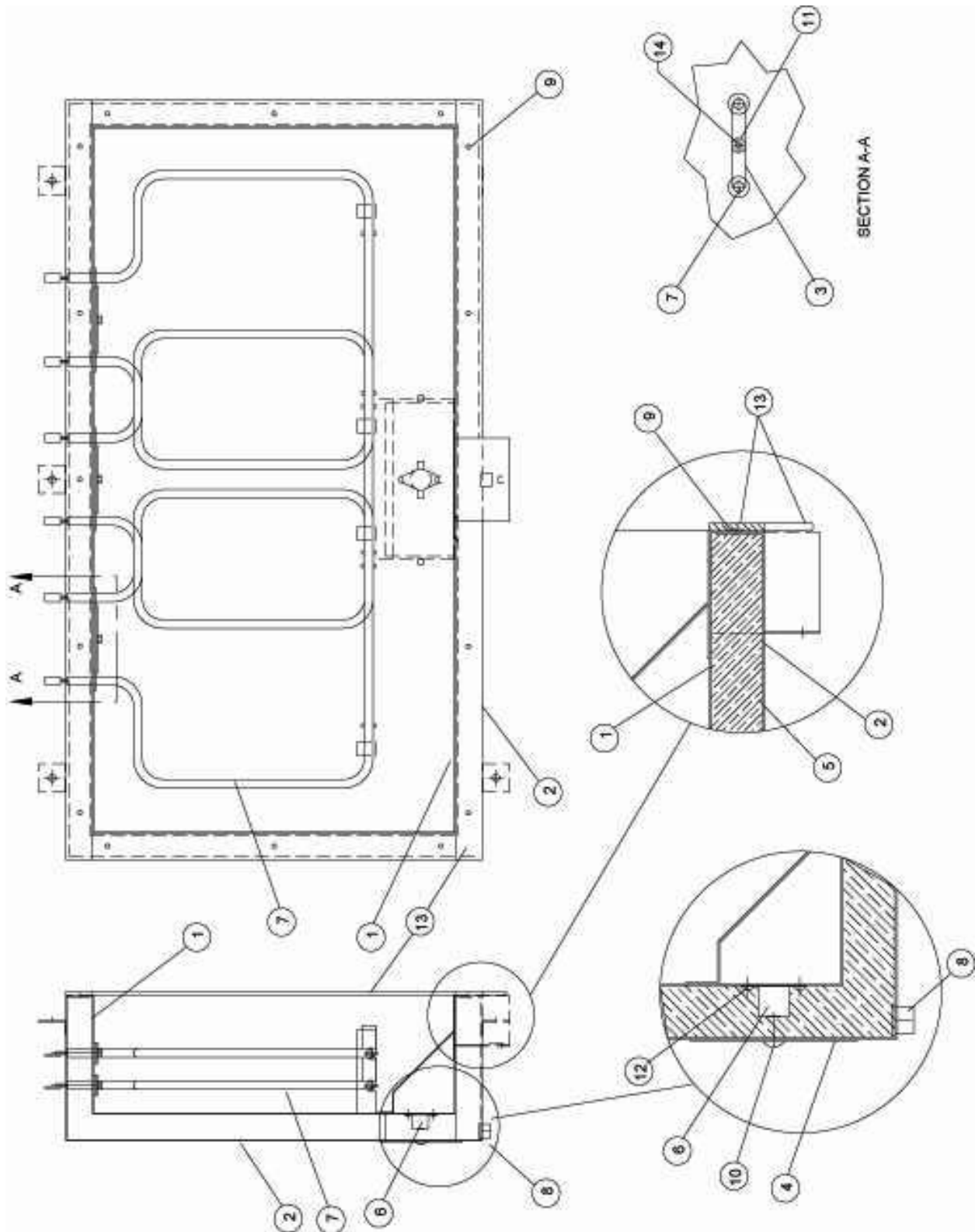

Table 3. Heated Plenum Assembly (AB56201300) Parts

ITEM #	PART #	QTY	DESCRIPTION
1	WB56201100	1	HEATED PLEN INSIDE WELD GO36
2	WB56201200	1	HEATED PLENUM OUTSIDE GO-36
3	FA56205002	3	BRACKET, ELEMENT RETAINING GO36
4	FB56205602	1	ACCESS PLATE, PLENUM OVER T SW
5	I0005	3	INSULATION, 1"TK
6	S0115	1	SWITCH, OVERTEMPERATURE
7	C0212	3	CALROD, 208/220V 1100W
8	F0158	1	BUSHING, BLK 1/2 HEYCO SNAP
9	RIV173	16	RIVET, SSD44 SSBS POP
10	SCR138	2	SCREW, 10 X 1/2 PHIL TR HD
11	NUT076	3	NUT, 10-24 PALNUTS
12	SCR334	2	SCREW, 4 X 3/8 SLTD PAN HD A
13	TP0026	7.5 ft.	TAPE, SILICONE RUBBER 1" X 1/8
14	SCR077	3	SCREW, STUD 10-24 X 1/2 WELD

Figure 4. Heated Plenum Assembly (AB56212500)

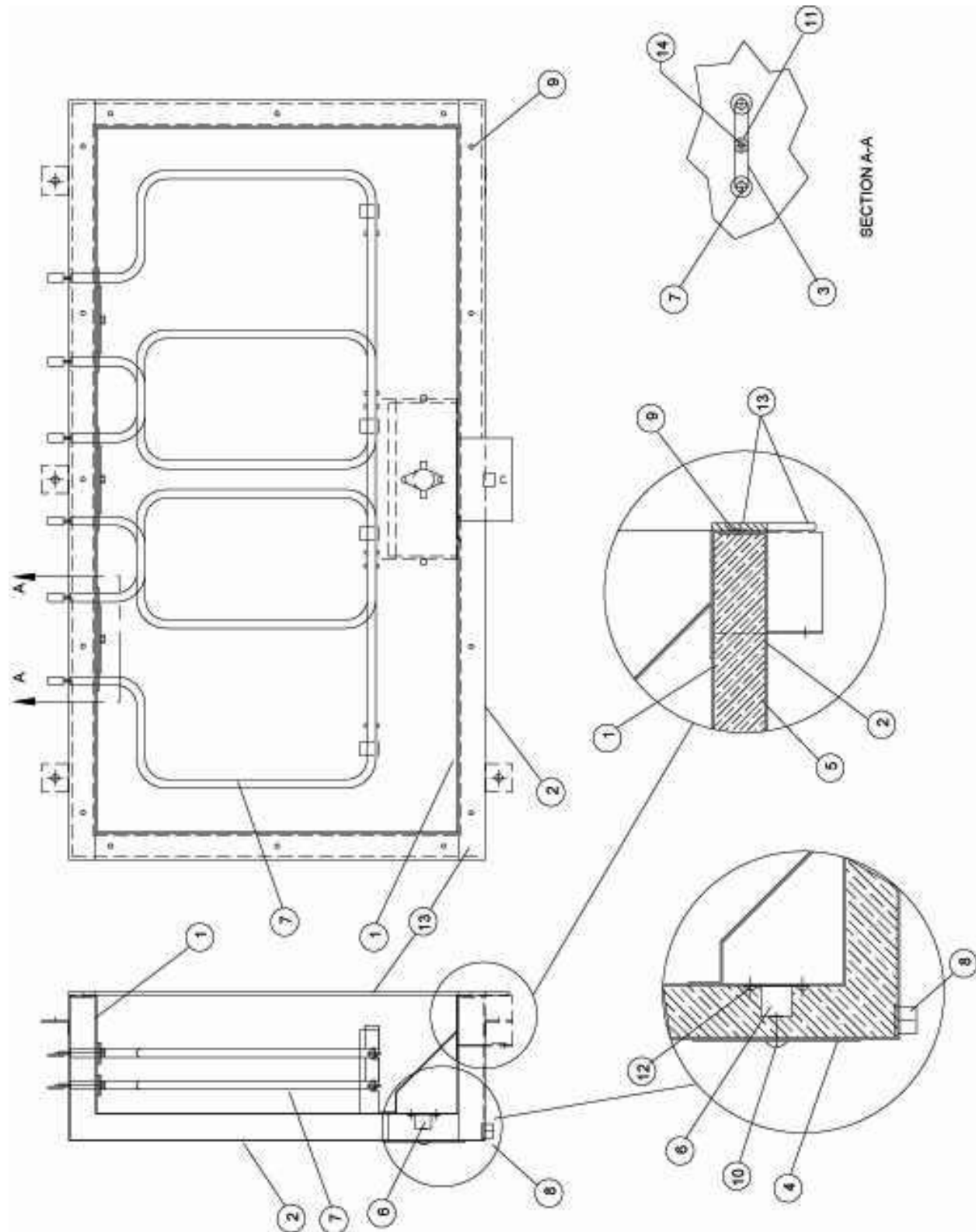

Table 4. Heated Plenum Assembly (AB56212500) Parts

ITEM #	PART #	QTY	DESCRIPTION
1	WB56212600	1	PLENUM INSIDE, WELD.4HRT, GO-36T
2	WB56212800	1	PLENUM OUTSIDE WELD.4HTR, GO-36T
3	FA56205002	4	BRACKET, ELEMENT RETAINING GO36
4	FB56205602	1	ACCESS PLATE, PLENUM OVER T SW
5	I0030	3	INSULATION, BGF MAT
6	S0115	1	SWITCH, OVERTEMPERATURE
7	C0212	4	CALROD, 208/220V 1100W
8	F0158	1	BUSHING, BLK 1/2 HEYCO SNAP
9	RIV173	16	RIVET, 1/8 SS (.187-.250)
10	SCR138	2	SCREW, 10 X 1/2 PHIL TR H
11	NUT076	4	NUT, 10-24 PALNUTS
12	SCR334	2	SCREW, 4 X 3/8 SLTD PAN
13	TP0026	7.5 ft.	TAPE, SILICONE RUBBER 1" X 1/8
14	SCR077	4	SCREW, STUD 10-24 X 1/2 WELD

Figure 5. Door Assembly

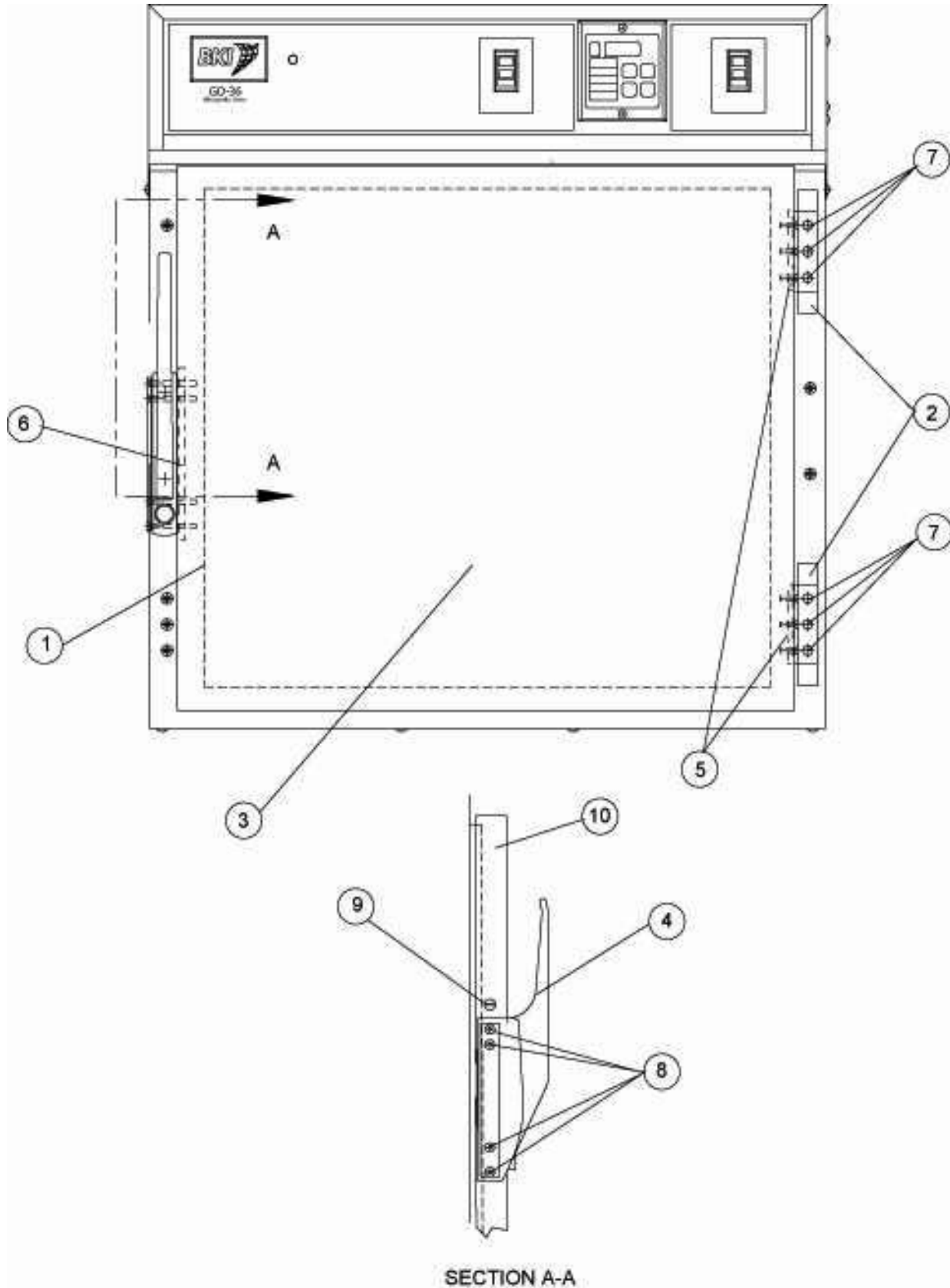

Table 5. Door Assembly Parts

ITEM #	PART #	QTY	DESCRIPTION
	AB56201700	1	DOOR ASSY
1	WB56202200	1	DOOR BACK WELDMENT, GO-36
2	H0075	2	HINGE, 4 INCH, 1-1/8" OFFSET
3	I0005	3.1 sq. ft.	INSULATION, 1"TK
4	L0103	1	LATCH, MAGNETIC COMPOSITE
5	MA56203710	2	MOUNTING PLATE, HINGE GO-36
6	MA56208510	1	MOUNTING PLATE, MAGNETIC LATCH GO-36
7	SCR006	6	SCREW, 8 X 1/2 PHIL PAN
8	SCR320	4	SCREW, 10-24 X 2 PHIL FLT
9	SCR300	1	SCREW, 10-24 X 3/4 SLTD TRUSS
10	WB56201900	1	DOOR FRONT WELD, GO-36

Figure 6. Stacking Kit Assembly

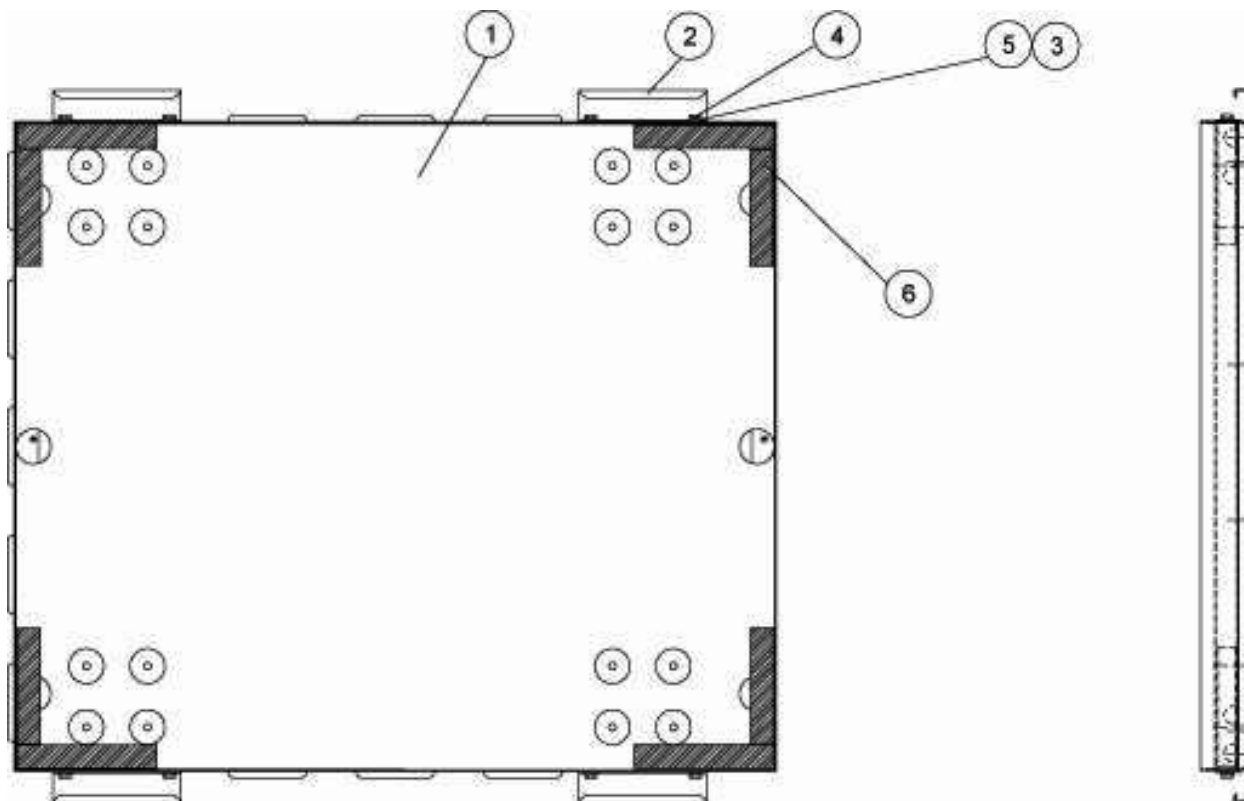

Table 6. Stacking Kit Assembly Parts

ITEM #	PART #	QTY	DESCRIPTION
	AB56210500	1	STACK KIT ASSY W/HANDLES, GO36
1	WB56210400	1	GO STACK KIT W/HANDLES WELDMNT
2	FA56210302	4	HANDLE, STACKING KIT GO36
3	F0079	8	THREAD INSERT 1/4-20 STEEL
4	SCR060	8	SCREW, 1/4-20 X 1 HEX CAP GR 5
5	WSH044	8	WASHER, 1/4 LOCK ZINC PLTD
6	TP0023	3.6667 ft.	TAPE, 1 X 1/8 ADHESIVE CORK
7	FA56210702 *	4	CONTROL UNIT SUPP SPACER GO
8	N0298 *	2	DECAL, CAUTION DISCONNECT PWR
9	WB56210600 *	1	DOLLY BASE GO36 STACK KIT WELD
10	LI0150 *	1	GO STACKING KIT INSTRUCTIONS
11	SCR060 *	16	SCREW, 1/4-20 X 1 HEX CAP
12	S0018 *	1	SEAL, SILICONE SEALANT ALUM
13	F0140 *	16	THREAD INSERT 1/4-20 STL HEX

* - Not Shown

Wiring Diagrams

Refer to the table below to find the wiring diagram associated with your unit.

Wiring Diagram	Figure #	Page #
GO-36, 208V, 240V, 1 Phase	Figure 7	31
GO-36, 240/415V, 220/380V, 1 Phase	Figure 8	32
GO-36T, 208V, 230V, 1 Phase	Figure 9	19

Figure 8. GO-36 (240/415V, 220/380V, 1 Phase)

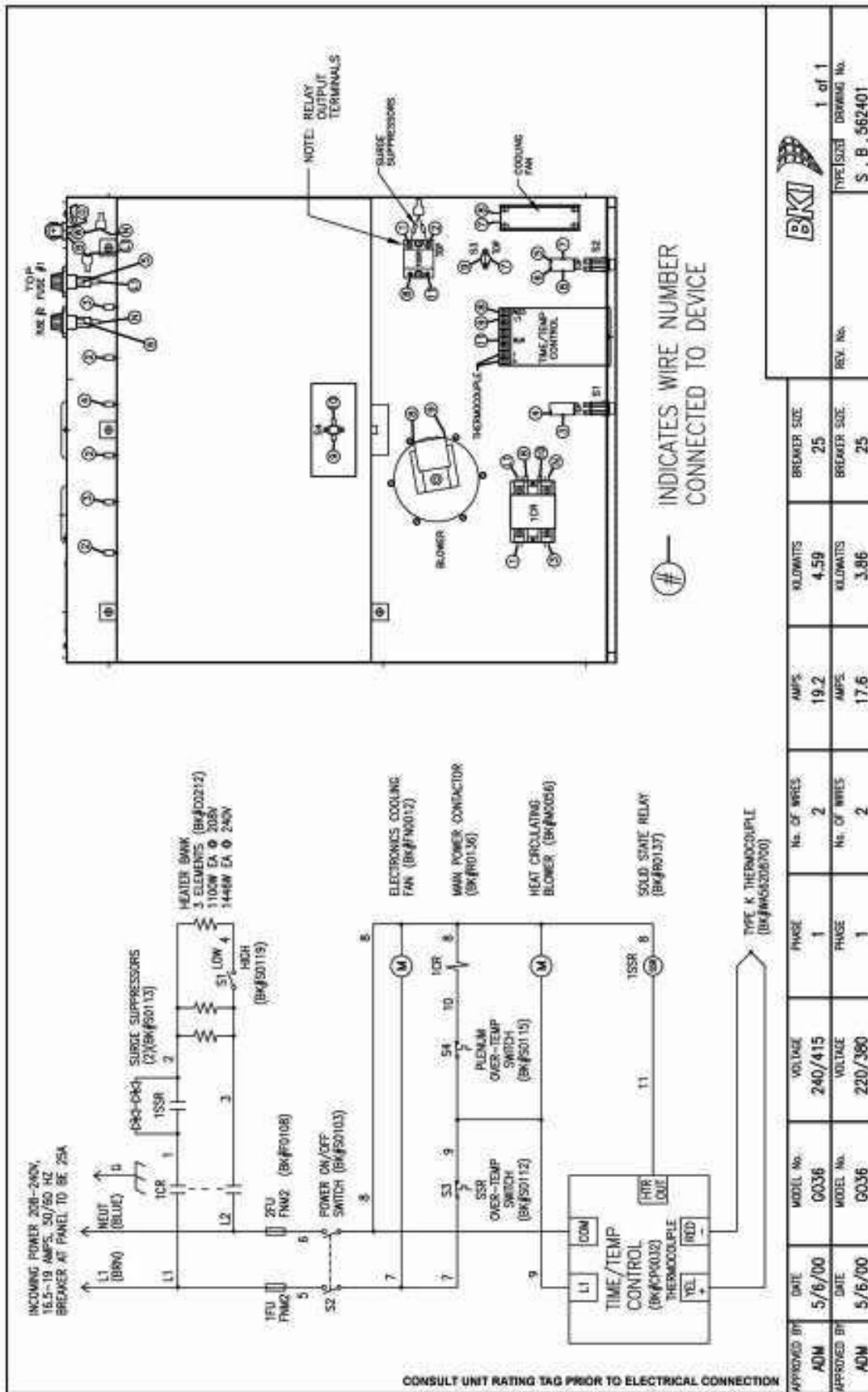
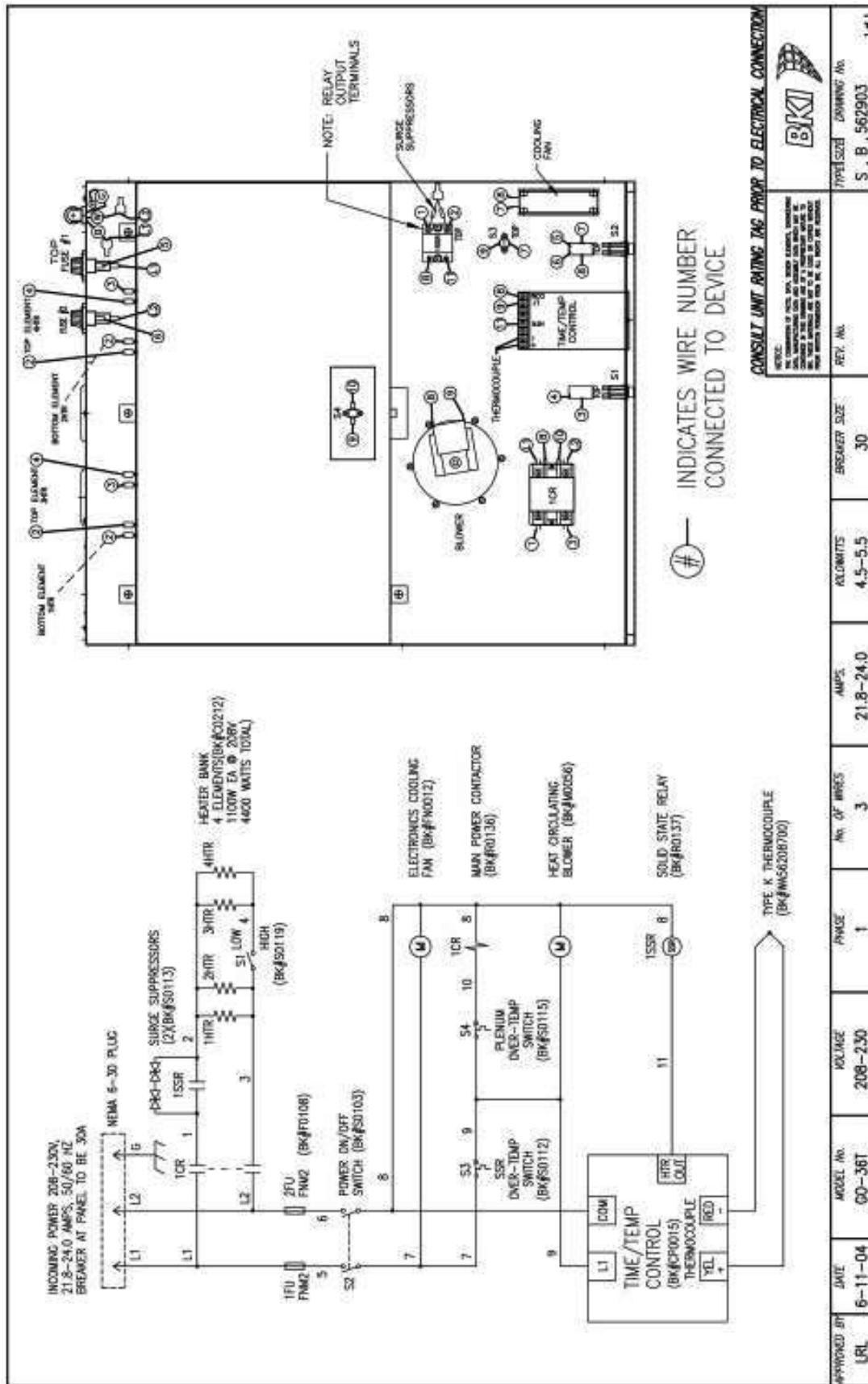

Figure 9. GO-36T (208V, 230V, 1 Phase)





2812 Grandview Dr., Simpsonville, S.C. 29680, USA
<http://www.bkideas.com>

Made and printed in the U.S.A
LI0208/0407

CS-TM-026.01

Revised 3/27/13

REVISION HISTORY

<u>REVISION</u>	<u>DATE</u>	<u>REVISED BY</u>	<u>DESCRIPTION</u>
01	03/27/13	KW	Initial Release-Supersedes all previous releases