

Heated/Humidified Holding Cabinet

Models HC-36, HC-36/2, HC-72

Service Manual

Serial Numbers 122695 and Higher



Fresh ideas in foodservice equipment

Warranty Information

LIMITED ONE YEAR WARRANTY

BKI (The "Company") warrants to the original purchaser that at time of shipment from the Company factory, this equipment will be free from defect in materials and workmanship. Written notice of a claim under this warranty must be received by the Company within ONE YEAR from the date of installation, but no longer than ONE YEAR AND THREE MONTHS from date of shipment from the factory. Defective conditions caused by abnormal use or misuse, lack of or improper maintenance, damage by third parties, alterations by unauthorized personnel, acts of God, failure to follow installation and/or operating instructions, or any other events beyond the reasonable control of the Company will NOT be covered under this warranty. The obligation of the Company under this warranty shall be limited to repairing or replacing (at the option of the Company) any part, with the exception of lamps, fuses, and glass (which are not covered under warranty), which is found defective in the reasonable opinion of the Company. Any part found defective by the Company will be repaired or replaced without charge F.O.B. factory, Simpsonville, South Carolina or F.O.B. authorized BKI Distributor. The Company and/or its authorized representatives will assume the normal replacement labor expense for the defective part for the period of the warranty as stated above, excluding travel and/or other expenses incidental to the replacement of the defective part, where replacement work is performed during standard business hours and not subject to overtime, holiday rates, and/or any additional fees. IN NO EVENT SHALL THE COMPANY BE LIABLE FOR LOSS OF USE, LOSS OF REVENUE OR LOSS OF PRODUCT OR PROFIT OR FOR INDIRECT OR CONSEQUENTIAL DAMAGES INCLUDING BUT NOT LIMITED TO, FOOD SPOILAGE OR PRODUCT LOSS. WARRANTY DOES NOT COVER GLASS BREAKAGE. THE ABOVE WARRANTY IS EXCLUSIVE AND ALL OTHER WARRANTIES, EXPRESS OR IMPLIED, ARE EXCLUDED INCLUDING THE IMPLIED WARRANTIES OF MERCHANTABILITY AND FITNESS FOR A PARTICULAR PURPOSE.

REPLACEMENT PARTS

Any appliance replacement part, with the exception of lamps, fuses, and glass, which proves to be defective in material or workmanship within ninety (90) days of installation will be replaced without charge F.O.B. Factory, Simpsonville, SC or F.O.B. authorized BKI Distributor. The user shall have the responsibility and expense of removing and returning the defective part to the Company as well as the cost of reinstalling the replacement or repaired part.

Table of Contents

Table of Contents	1
Introduction	2
Safety Precautions	2
Safety Signs and Messages	2
Safe Work Practices	3
Safety Labels	5
Installation	6
Instructions For Shipping Damage	6
Location and Placement	6
Electrical Information	6
Replacement Parts	7
Assemblies	7
Accessories	28
Wiring Diagrams	29
Notes	33

Introduction

Congratulations! You have chosen a **Heated/Humidified Holding Cabinet** that will give you many years of fine service from the original manufacturer, **BKI**.

The **BKI** name and trademark on this unit assures you of the finest in design and engineering — that it has been built with care and dedication — using the best materials available. Attention to the operating instructions regarding proper installation, operation, and maintenance will result in long lasting dependability to insure the highest profitable return on your investment.

NOTICE

PLEASE READ THIS ENTIRE MANUAL BEFORE OPERATING THE UNIT. If you have any questions, please contact your **BKI** Distributor. If they are unable to answer your questions, contact the **BKI** Technical Service Department, toll free: 1-800-927-6887. Outside the U.S., call 1-864-963-3471.

Safety Precautions

Always follow recommended safety precautions listed in this manual. Below is the safety alert symbol. When you see this symbol on your equipment, be alert to the potential for personal injury or property damage.



Safety Signs and Messages

The following Safety signs and messages are placed in this manual to provide instructions and identify specific areas where potential hazards exist and special precautions should be taken. Know and understand the meaning of these instructions, signs, and messages. Damage to the equipment, death or serious injury to you or other persons may result if these messages are not followed.

⚠ DANGER

This message indicates an imminently hazardous situation that, if not avoided, will result in death or serious injury.

⚠ WARNING

This message indicates a potentially hazardous situation, which, if not avoided, could result in death or serious injury.

⚠ CAUTION

This message indicates a potentially hazardous situation, which, if not avoided, may result in minor or moderate injury. It may also be used to alert against unsafe practices.

NOTICE

This message is used when special information, instructions or identification are required relating to procedures, equipment, tools, capacities and other special data.

Safe Work Practices



Beware of High Voltage

This equipment uses high voltage. Serious injury can occur if you or any untrained or unauthorized person installs, services, or repairs this equipment. Always Use an Authorized Service agent to Service Your Equipment.

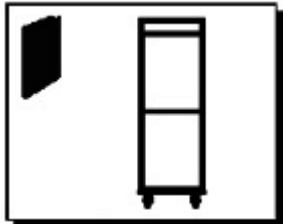

Keep this manual with the Equipment

This manual is an important part of your equipment. Always keep it near for easy access. If you need to replace this manual, contact:

BKI

Technical Services Department
 P.O. Box 80400
 Simpsonville, S.C. 29680-0400
 Or call toll free: 1-800-927-6887
 Outside the U.S., call 864-963-3471



Protect Children

Keep children away from this equipment. Children may not understand that this equipment is dangerous for them and others.

NEVER allow children to play near or operate your equipment.



Keep Safety Labels Clean and in Good Condition

Do not remove or cover any safety labels on your equipment. Keep all safety labels clean and in good condition. Replace any damaged or missing safety labels. Refer to the Safety Labels section for illustration and location of safety labels on this unit. If you need a new safety label, obtain the number of the specific label illustrated on page 5, then contact:

BKI

Technical Services Department
 P.O. Box 80400
 Simpsonville, S.C. 29680-0400
 Or call toll free: 1-800-927-6887
 Outside the U.S., call 864-963-3471

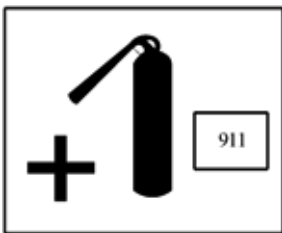

Be Prepared for Emergencies

Be prepared for fires, injuries, or other emergencies.

Keep a first aid kit and a fire extinguisher near the equipment. You must use a 40-pound Type BC fire extinguisher and keep it within 25 feet of your equipment.

Keep emergency numbers for doctors, ambulance services, hospitals, and the fire department near your telephone.



Know your responsibilities as an Employer

- Make certain your employees know how to operate the equipment.
- Make certain your employees are aware of the safety precautions on the equipment and in this manual.
- Make certain that you have thoroughly trained your employees about operating the equipment safely.
- Make certain the equipment is in proper working condition. If you make unauthorized modifications to the equipment, you will reduce the function and safety of the equipment.

Safety Labels

N0158

<p>⚠ WARNING CONNECT ONLY TO APPROVED 3 PRONG GROUNDED CIRCUIT. FAILURE TO DO SO COULD RESULT IN SERIOUS INJURY.</p>	<p>⚠ WARNING CONNECT ONLY TO APPROVED 3 PRONG GROUNDED CIRCUIT. FAILURE TO DO SO COULD RESULT IN SERIOUS INJURY.</p>
<p>DO NOT COVER OR REMOVE THIS LABEL</p>	
<p>N0158</p>	

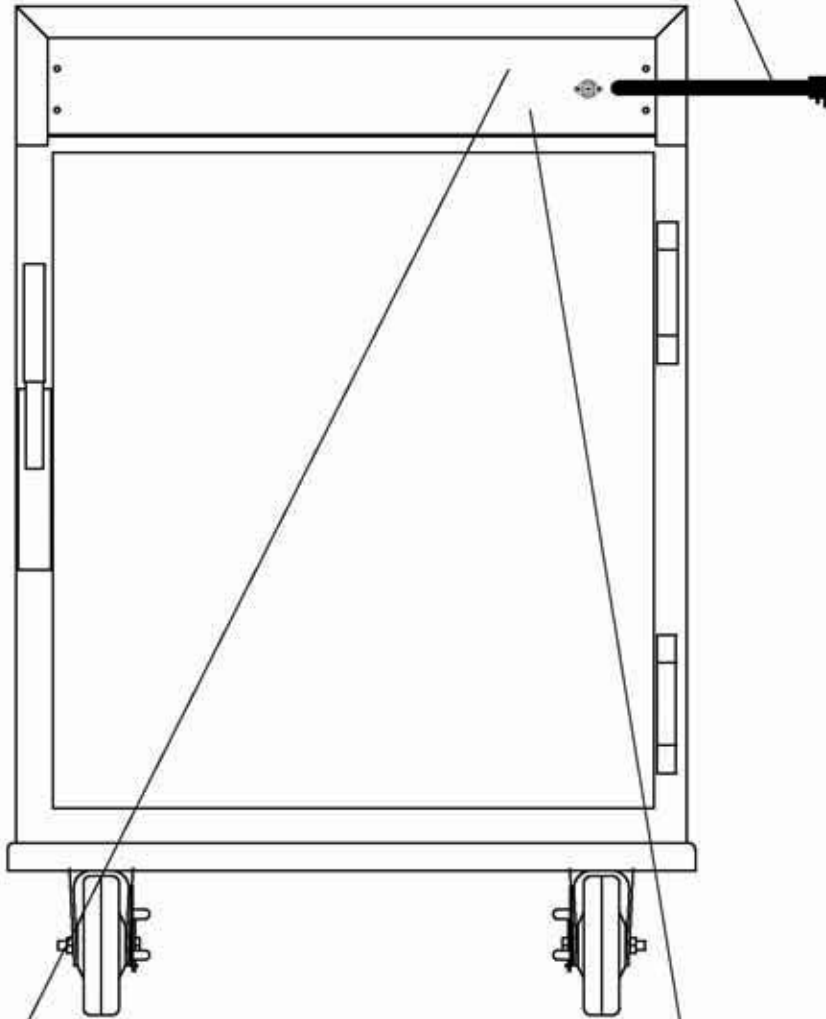

N0298

<p>⚠ CAUTION</p> <p>THIS APPLIANCE HAS MORE THAN ONE POWER SUPPLY CONNECTION POINT. DISCONNECT ALL POWER SUPPLIES BEFORE SERVICING.</p>
<p>N0298</p>

N0202

	<p>⚠ DANGER</p> <p>HIGH VOLTAGE. Turn power off before servicing. May have more than one disconnect switch. <small>Do not cover or remove label. N0202</small></p>
--	---

Installation

⚠ WARNING

Serious injury, equipment damage or death could result if attempting to install this unit yourself. Ensure that an authorized BKI service agent installs the unit.

Instructions For Shipping Damage

You are responsible for filing all freight claims with the delivering truck line. Inspect all cartons and crates for damage when they arrive. If there is damage noted to shipping crates or cartons, or, if a shortage is found, note this on the bill of lading (all copies) before signing.

If damage is detected when the equipment is uncrated, immediately call the delivering truck line and follow up the call with a written report indicating concealed damage to your equipment. Ask for an immediate inspection of your concealed damage item. Crating material **MUST** be retained to show the inspector from the truck line.

Location and Placement

Move the unit to a permanent location and lock the swivel casters before using.

Electrical Information

⚠ WARNING

Electrocution, equipment failure or property damage could result if an unlicensed electrician performs the electrical installation. Ensure that a licensed electrician perform the electrical installation in accordance with local codes, or in the absence of local codes, with the National Electrical Code, ANSI NFPA 70-20XX.

This unit, when installed by an authorized BKI service agent, must be wired for use in accordance with all applicable local, state, and federal codes. For specific electrical requirements and connections refer to the wiring diagram attached to the unit or provided in the Service Manual.

Replacement Parts

Use the information in this section to identify replacement parts. To order replacement parts, call your local BKI sales and service representative. Before calling, please note the serial number on the rating tag affixed to the unit.

Assemblies

Description	Assembly #	Figure #	Table #
BASE (HC72, HC36)	AB57028800 AB57008000	Figure 1	Table 1
DOOR HARDWARE (HC36 LEFT HINGE)	AN57020800	Figure 2	Table 2
DOOR/HARDWARE (HC36 RIGHT HINGE)	AB57017100	Figure 4	Table 4
DOOR/HARDWARE (HC72 LEFT HINGE)	AB57018300	Figure 5	Table 5
DOOR/HARDWARE (HC72 RIGHT HINGE)	AB57015700	Figure 7	Table 7
HEAT MODULE (120V HC36 VENTED)	AN57028300	Figure 8	Table 8
HEAT MODULE (120V HC36)	AN57022600		
HEAT MODULE (120V HC72)	AN57023700		
HEAT MODULE (240V HC72 VENTED)	AN57028000		
HEAT MODULE (HC36 ENGLAND)	AN57022700		
HEAT MODULE (HC72 ENGLAND)	AN57023800		
TRAY RACK (HC36)	AB57017000	Figure 14	-
LOWER TRAY RACK (HC72)	AB57008200	Figure 15	-
UPPER TRAY RACK (HC72)	AB57008300	Figure 16	-

Figure 1. Base (HC72, HC36)

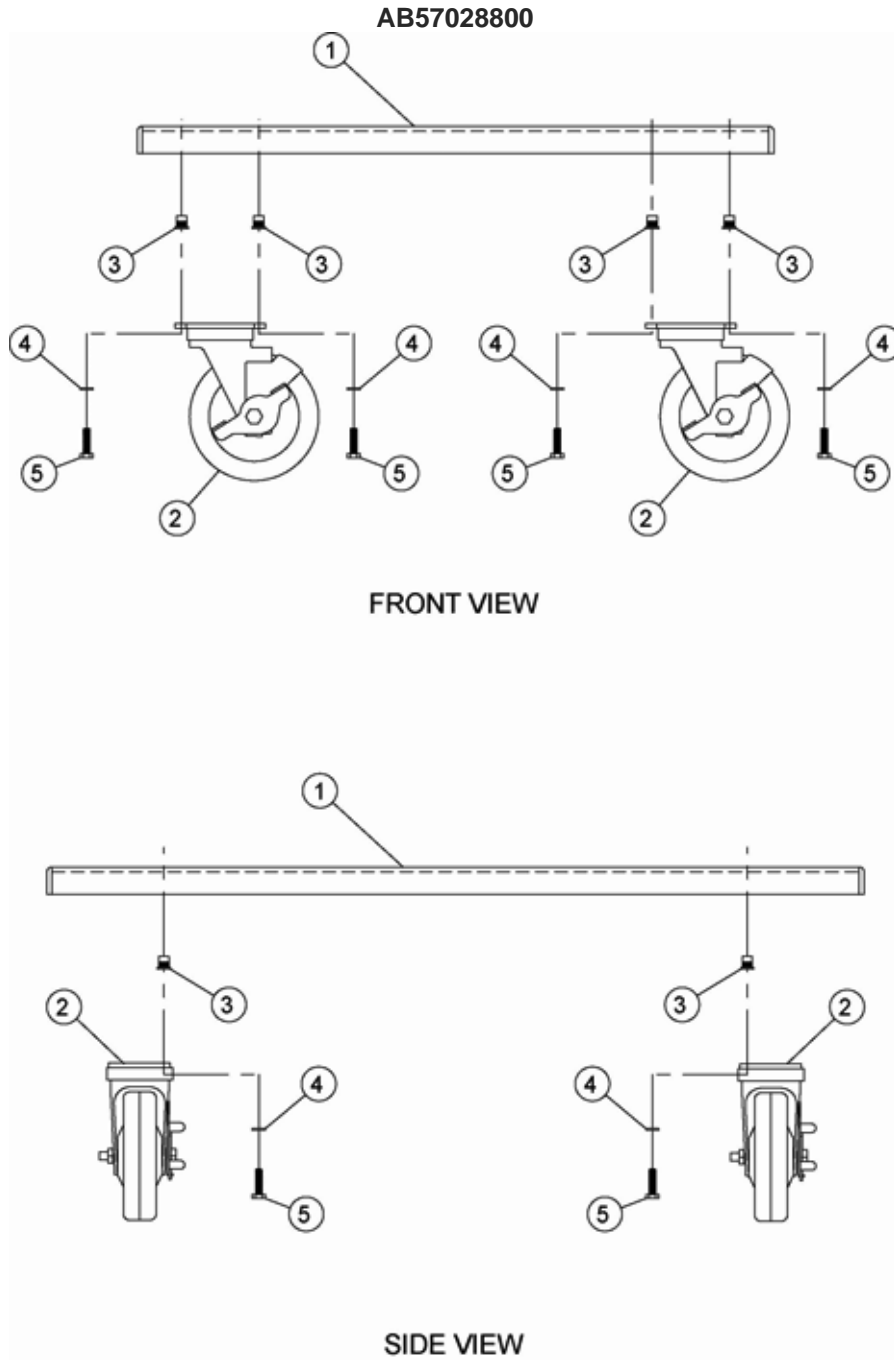

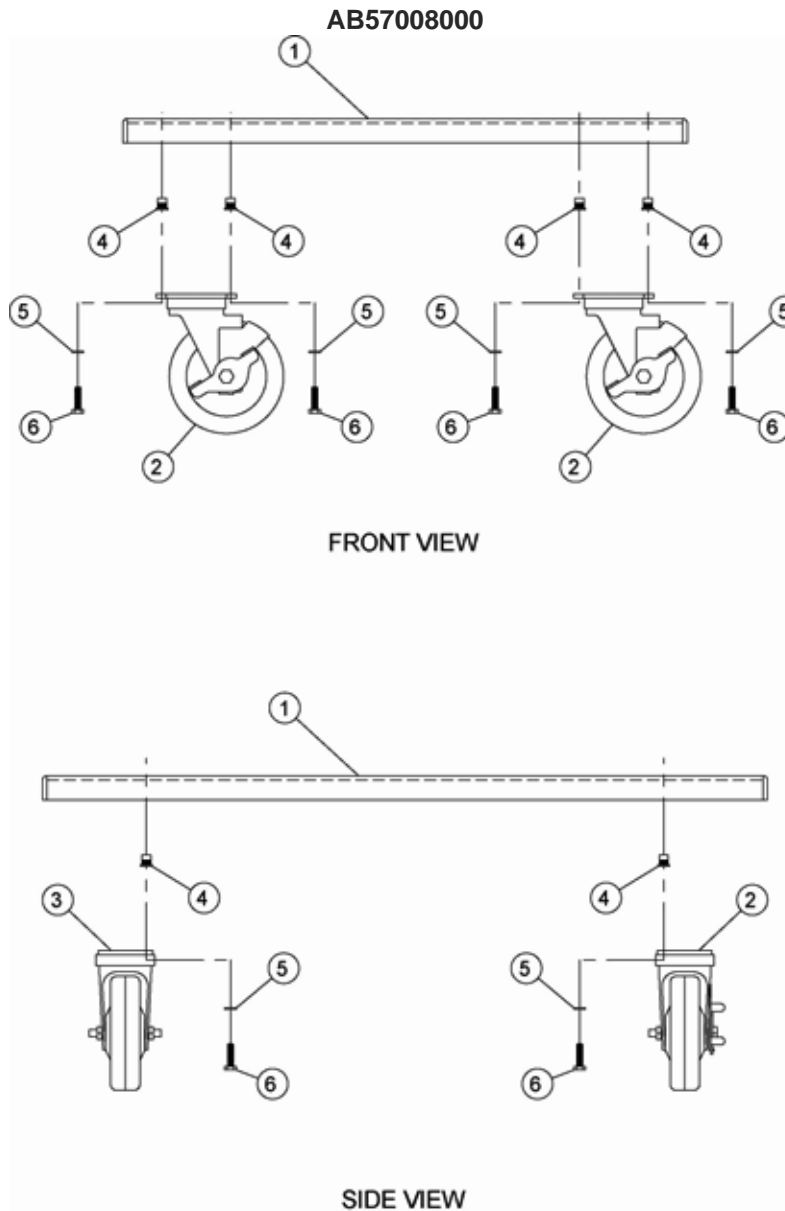

Table 1. Base (HC72, HC36) Parts

ITEM #	PART #	QTY	DESCRIPTION
AB57028800			
1	WB57013600	1	BASE WELDMENT HC'S FB57013610
2	C0415	4	CASTER, 3"SWIVEL W/BREAK
3	F0082	12	THREAD INSERT 1/4-20 STEEL
4	WSH102	12	WASHER, 1/4 INT LOCK
5	SCR060	12	SCREW, 1/4-20 X 1 HEX CAP
AB57008000			
1	WB57013600	1	BASE WELDMENT HC'S
2	C0411	2	CASTER, W/BRAKE HC-36, 72
3	C0412	2	CASTER, W/O BRAKE
4	F0082	16	THREAD INSERT 1/4-20 STEEL
5	WSH102	16	WASHER, 1/4 INT LOCK
6	SCR060	16	SCREW, 1/4-20 X 1 HEX CAP

Figure 2. Door Hardware (HC36 Left Hinge)

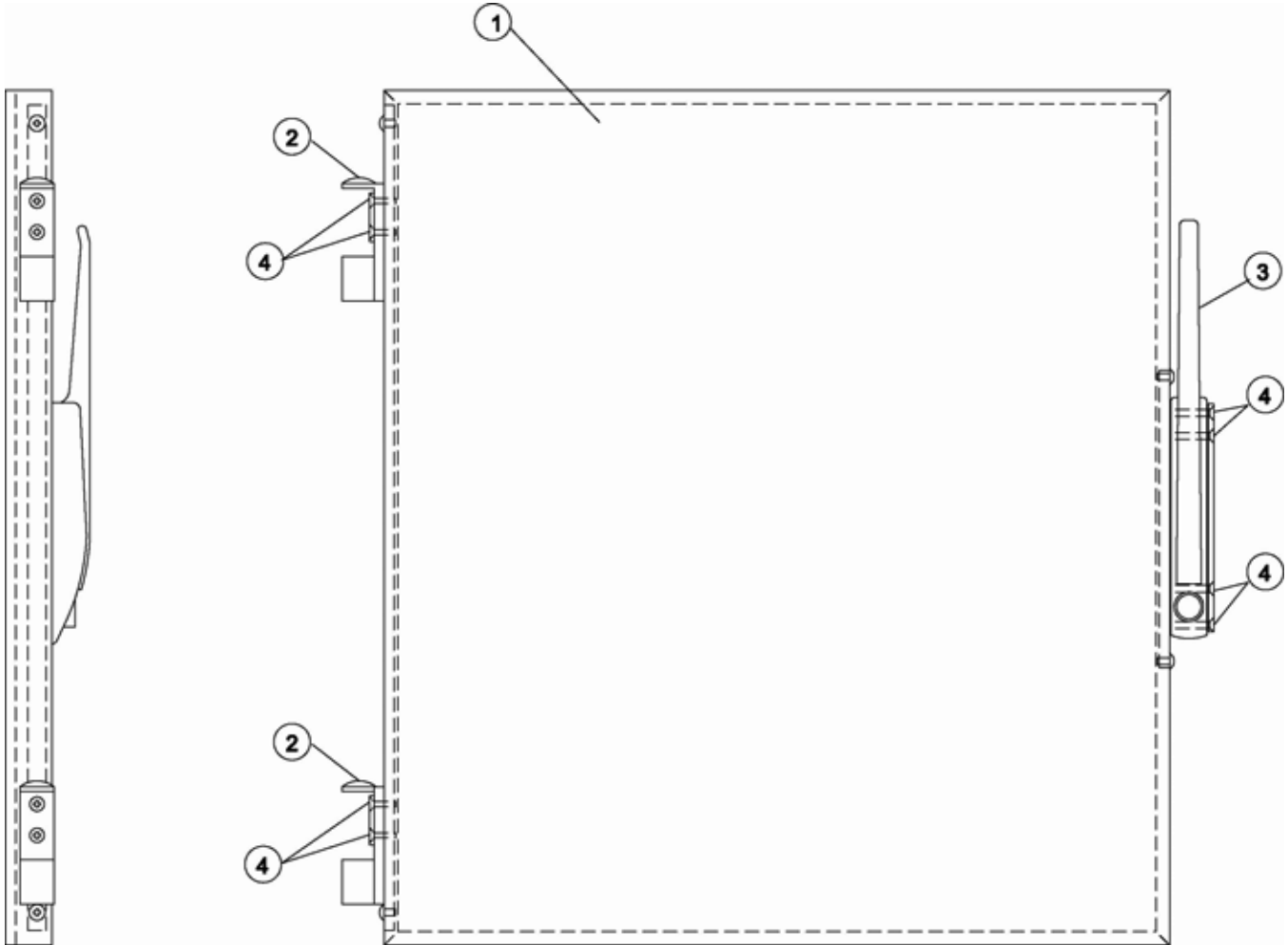

Table 2. Door Hardware (HC36 Left Hinge) Parts

ITEM #	PART #	QTY	DESCRIPTION
1	AC57009200 (see <i>Figure 3</i>)	1	DOOR ASSY HC36
2	H0008	2	HINGE, FOR HC-36, 72
3	L0100	1	LATCH, MAGNETIC HC-36, 72
4	SCR197	8	SCREW, 10-24 X 1 1/2 PHIL FL

Figure 3. Door Assembly HC36

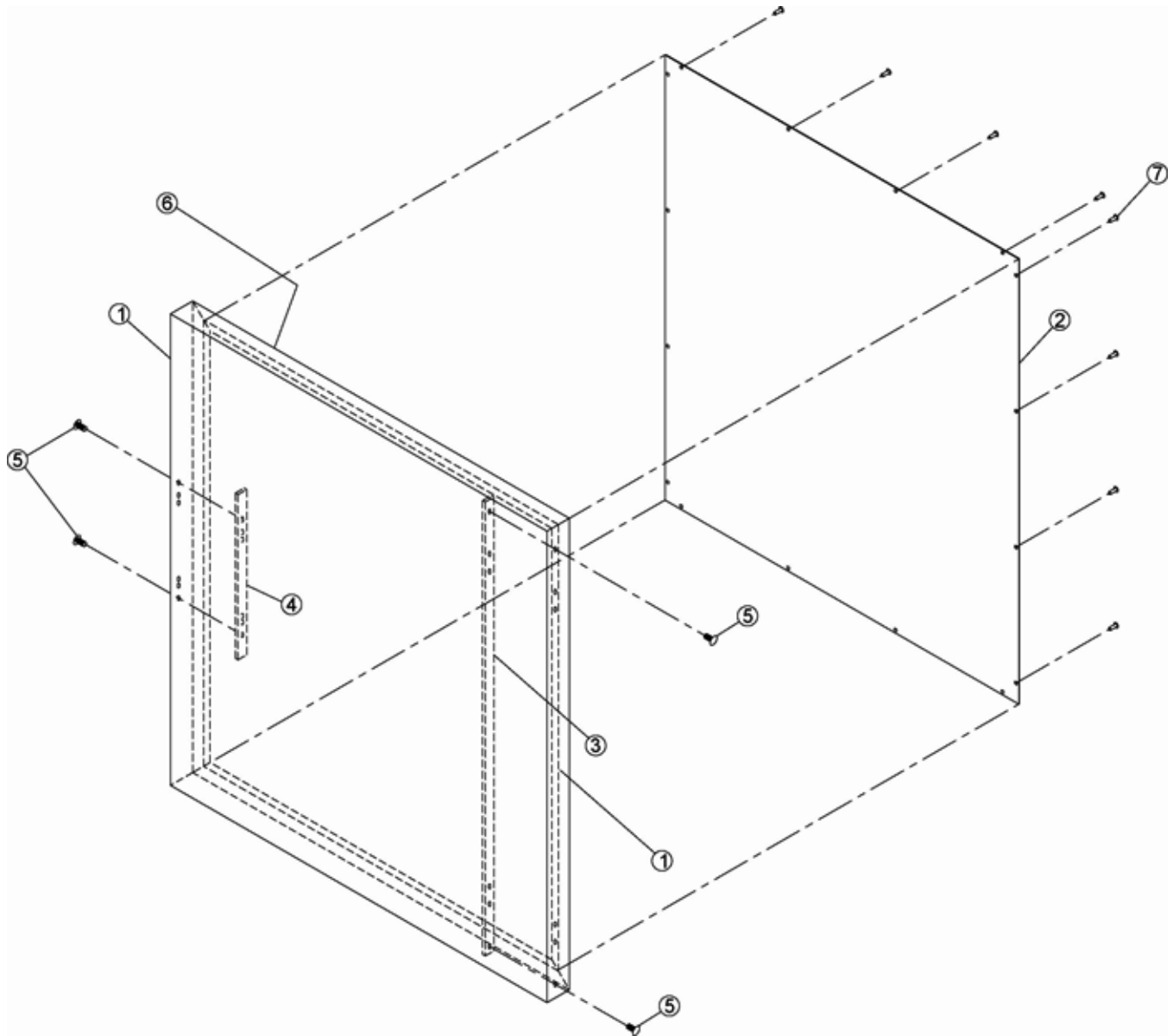

Table 3. Door Assembly HC36 Parts

ITEM #	PART #	QTY	DESCRIPTION
1	WB57004200	1	DOOR, CORNERS WELDED
2	FB57004102	1	INSIDE DOOR, HC-36
3	MB57011210	1	MOUNTING PLATE, HINGE HC-36
4	MB57005410	1	MOUNTING PLATE, LATCH HC
5	SCR383	4	SCREW, 10-24 X 1/2" PHIL TRUSS HD
6	I0010	3.5 SF	INSULATION, RANGE 1" FIBERGLASS
7	RIV180	16	RIVET, 1/8 SS (.063-.125)

Figure 4. Door/Hardware (HC36 Right Hinge)

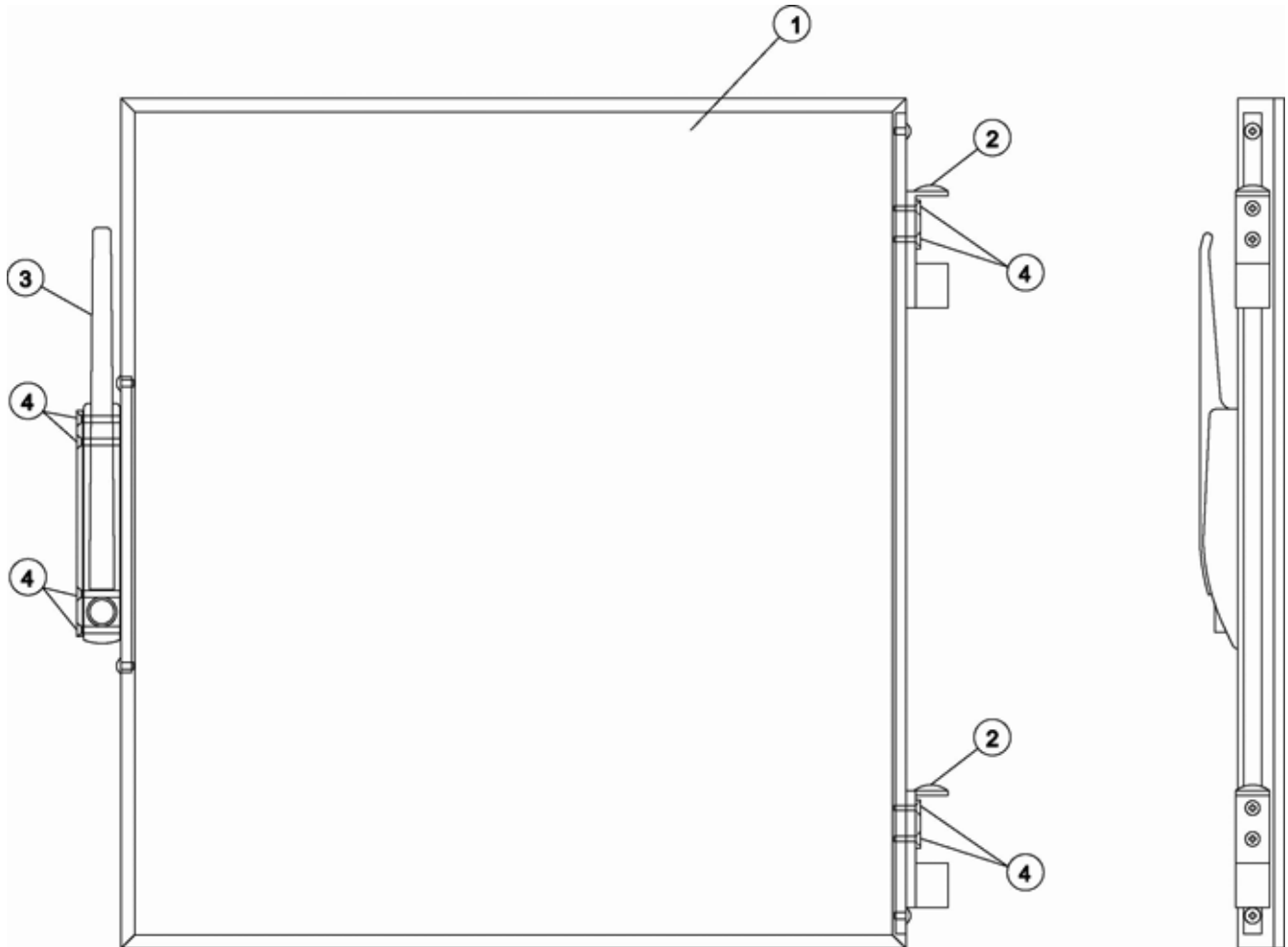

Table 4. Door/Hardware (HC36 Right Hinge) Parts

ITEM #	PART #	QTY	DESCRIPTION
1	AC57009200 (see Figure 3)	1	DOOR ASSY HC36
2	H0008	2	HINGE, FOR HC-36, 72
3	L0100	1	LATCH, MAGNETIC HC-36, 72
4	SCR197	8	SCREW, 10-24 X 1 1/2 PHIL FL

Figure 5. Door/Hardware (HC72 Left Hinge)

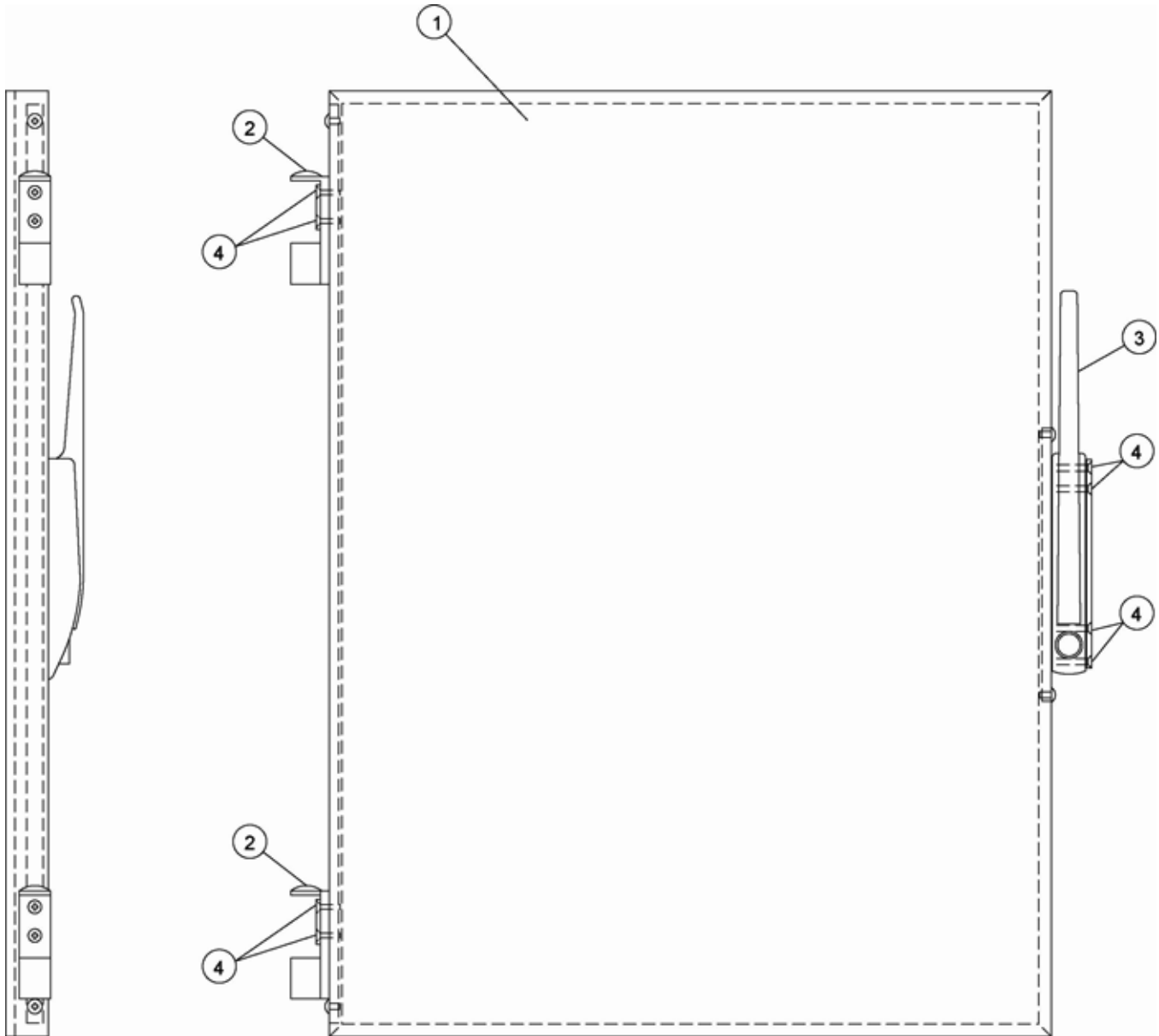

Table 5. Door/Hardware (HC72 Left Hinge) Parts

ITEM #	PART #	QTY	DESCRIPTION
1	AC57007900 (see Figure 6)	1	DOOR ASSY HC72
2	H0008	2	HINGE, FOR HC-36, 72
3	L0100	1	LATCH, MAGNETIC HC-36, 72
4	SCR197	8	SCREW, 10-24 X 1 1/2 PHIL FL

Figure 6. Door Assembly HC72

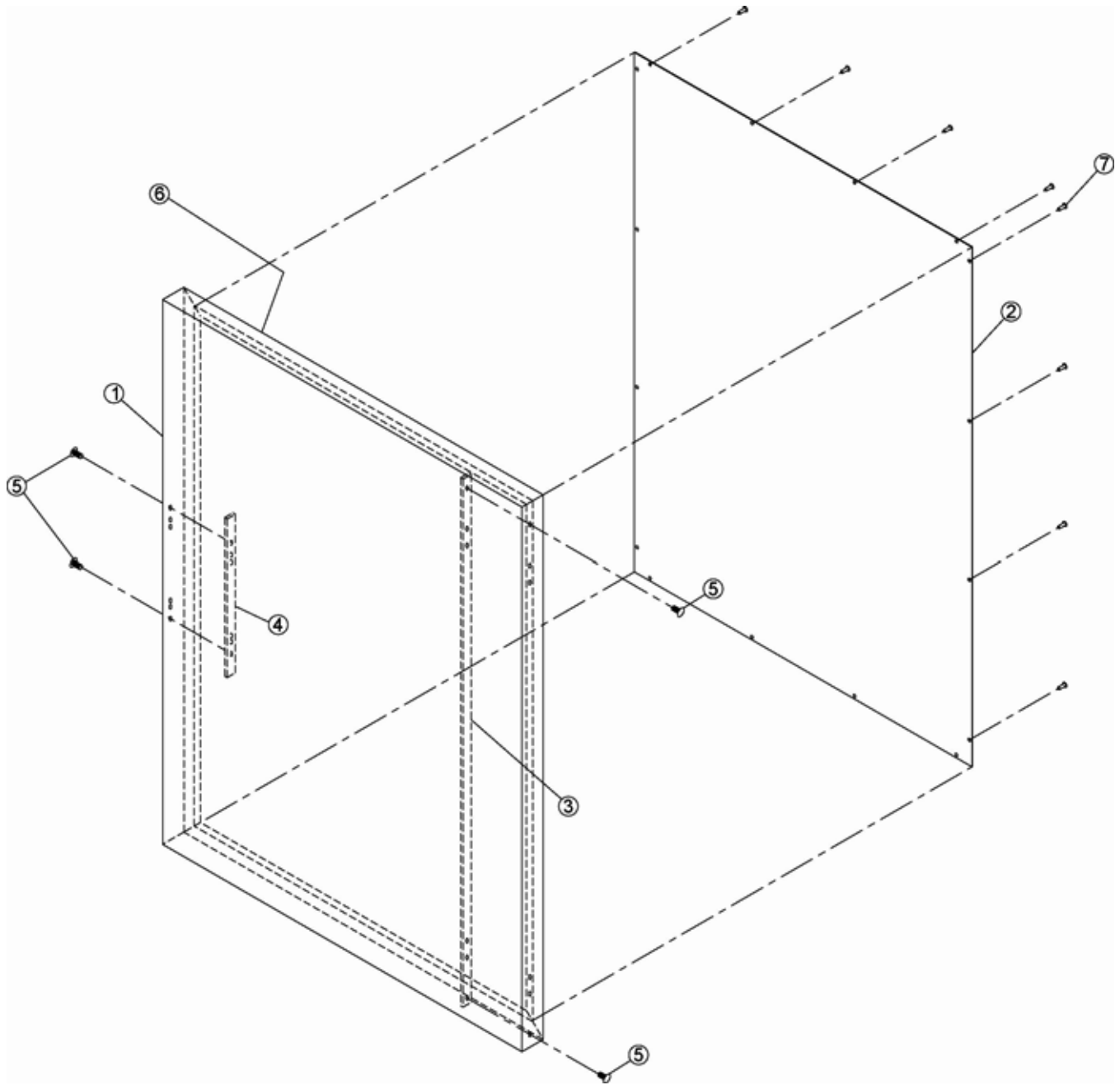

Table 6. Door Assembly HC72 Parts

ITEM #	PART #	QTY	DESCRIPTION
1	WB57000300	1	DOOR, CORNERS WELDED HC72
2	FB57024902	1	INSIDE DOOR HC72
3	MB57005410	1	MOUNTING PLATE, LATCH HC
4	MB57005100	1	MTG PLATE, HINGE HC72
5	SCR383	4	SCREW, 10-24 X 1/2" PHIL TRUSS HD
6	I0010	4	INSULATION, RANGE 1" FIBERGLASS
7	RIV180	16	RIVET, 1/8 SS (.063-.125)

Figure 7. Door/Hardware (HC72 Right Hinge)

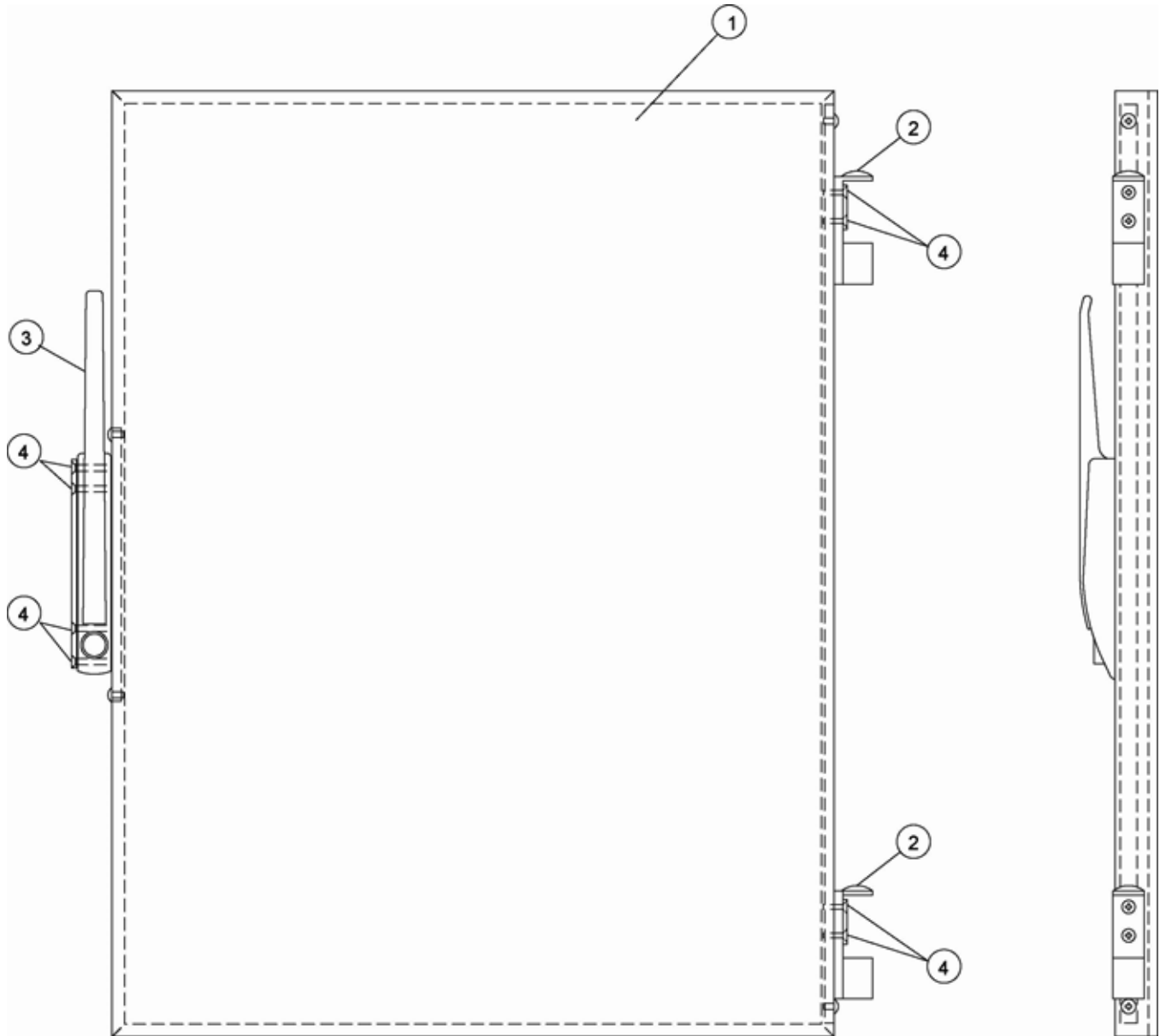

Table 7. Door/Hardware (HC72 Right Hinge) Parts

ITEM #	PART #	QTY	DESCRIPTION
1	AC57007900 (see Figure 6)	1	DOOR ASSY HC72
2	H0008	2	HINGE, FOR HC-36, 72
3	L0100	1	LATCH, MAGNETIC HC-36, 72
4	SCR197	8	SCREW, 10-24 X 1 1/2 PHIL FL

Figure 8. Heat Module

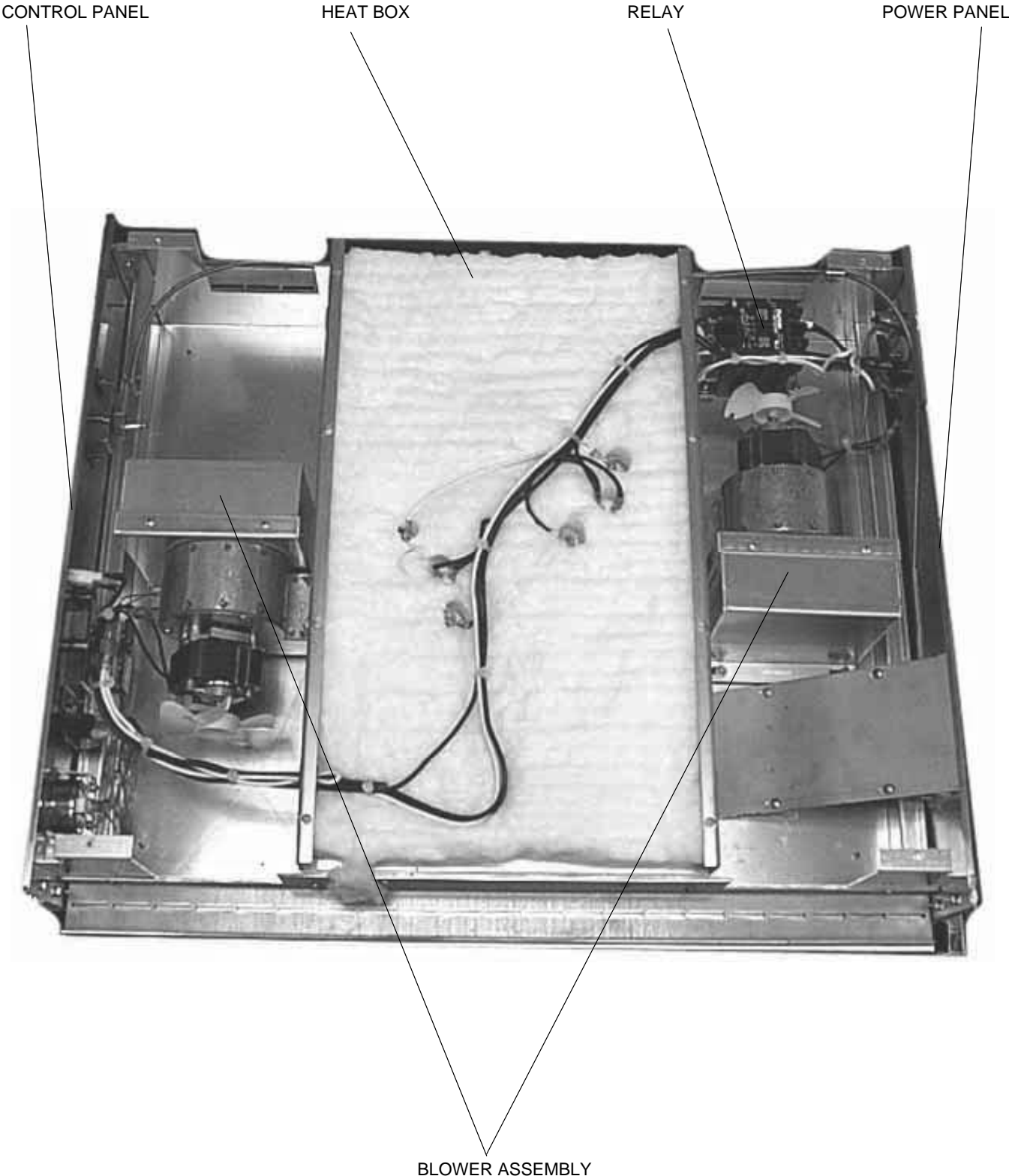

Table 8. Heat Module Parts

PART	QTY	DESCRIPTION	FIGURE #	TABLE #
R0002 or R0004	1	RELAY, 2 POLE 110/120V or RELAY, 2 POLE 208/240V	Figure 8	-
AB57022500	2	BLOWER (HC 36/72, 230V)	Figure 9	Table 9
AB57022400	2	BLOWER (HC36/72, 120V)	Figure 10	Table 10
AN57022800	1	CONTROL PANEL HC36 120V	Figure 11	Table 11
AN57023000	1	CONTROL PANEL HC36 240V ENGLAND		
AN57027200	1	CONTROL PANEL HC36 VENTED		
AN57023600	1	CONTROL PANEL HC72 120V		
AN57024000	1	CONTROL PANEL HC72 240V ENGLAND		
AN57028400	1	CONTROL PANEL HC72 VENTED		
AC57022200	1	HEAT BOX HC36 120V	Figure 12	Table 12
AN57023500	1	HEAT BOX HC72 120V		
AN57024100	1	HEAT BOX HC36 230V ENGLAND		
AN57023900	1	HEAT BOX HC72 240V ENGLND		
AN57028700	1	POWER SUPPLY PANEL 120V HC36/72 VENTED	Figure 13	Table 13
AN57027300	1	POWER SUPPLY PANEL 240V HC36/72 VENTED		
AN57022900	1	POWER SUPPLY PANEL HC72 120V		
AN57023100	1	POWER SUPPLY PANEL HC72 240V		

Figure 9. Blower (HC 36/72, 230V)

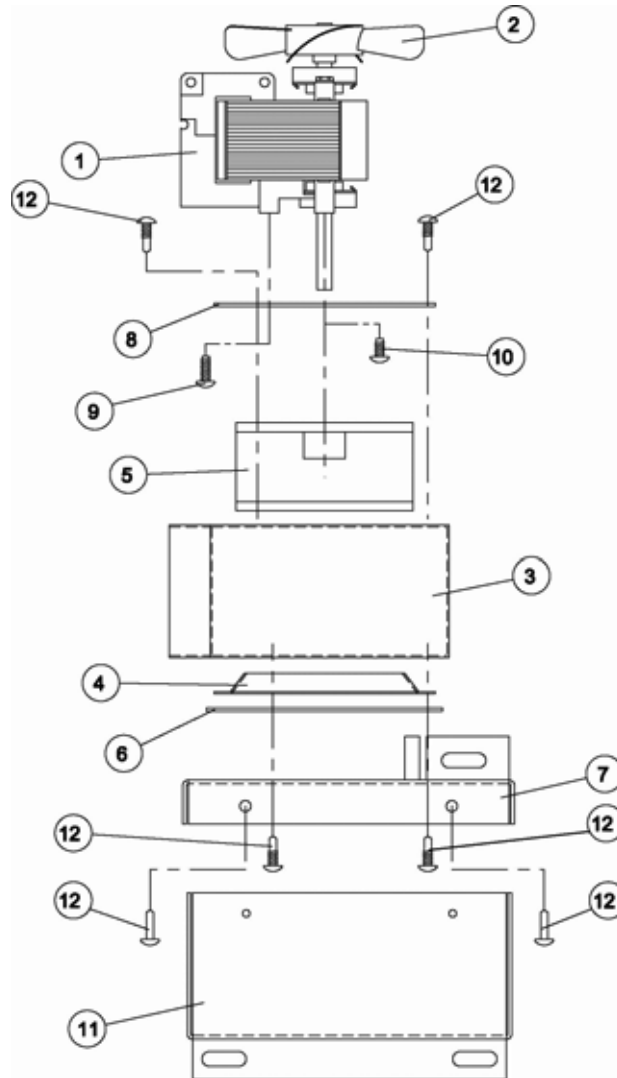

Table 9. Blower (HC 36/72, 230V) Parts

ITEM #	PART #	QTY	DESCRIPTION
1	M0068	1	MOTOR, 208/240V 60 HZ
2	FN0008	1	FAN BLADE
3	FN0009	1	BLOWER HOUSING
4	FN0010	1	INLET RING
5	FN0011	1	BLOWER WHEEL, 3" DIA 1 1/2" W
6	G0085	1	GASKET, SILICONE RUBBER HC
7	FB57021410	1	INTAKE COVER, HC36 AIR DIS BOX
8	FB57002902	1	BLOWER MTG PLATE
9	SCR323	2	SCREW, 6-32 X 1/2 PHIL RD
10	SCR117	2	SCREW, 6-32 X 3/8 PHIL RD
11	FB57021510	1	INTAKE BODY AIR DIST BOX HC36
12	SCR354	6	SCREW, 8 X 1/2 PHIL PAN
13	TP0021	0.63 FT	TAPE, ARMAFLEX 1/8 X 3/4 X 50'
14	RIV171	6	RIVET, 1/8 ALUM (.187-.250)

Figure 10. Blower (HC 36/72, 120V)

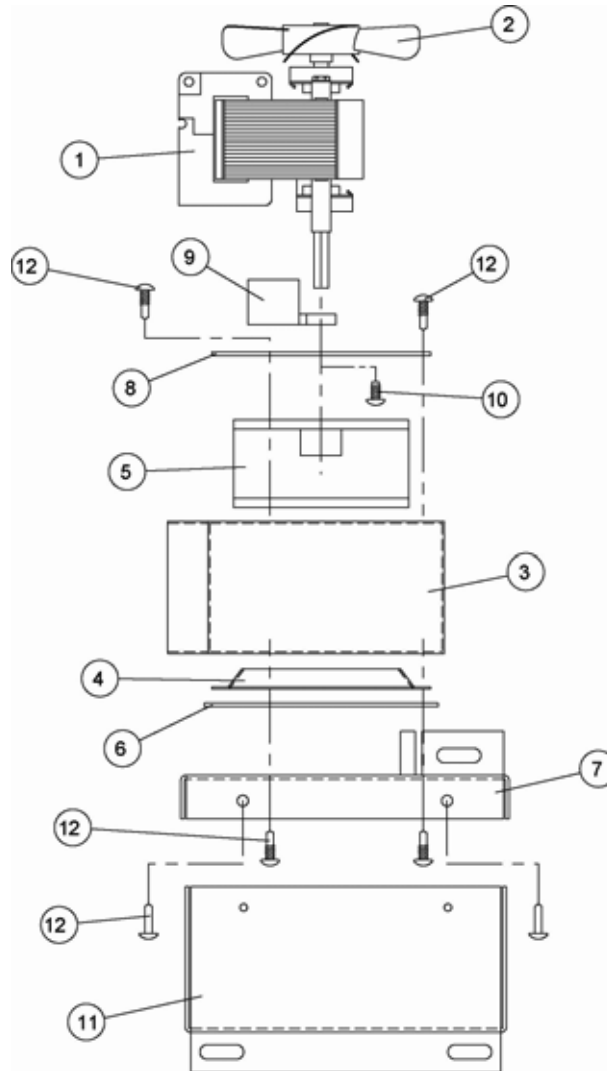
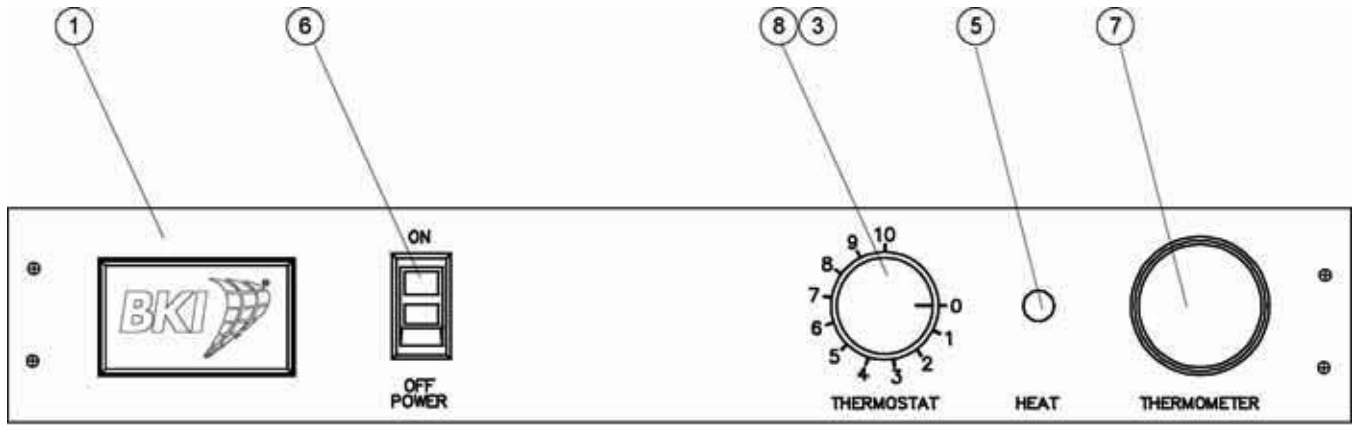

Table 10. Blower (HC 36/72, 120V) Parts

ITEM #	PART #	QTY	DESCRIPTION
1	M0063	1	MOTOR, 120V SHADED POLE
2	FN0008	1	FAN BLADE
3	FN0009	1	BLOWER HOUSING
4	FN0010	1	INLET RING
5	FN0011	1	BLOWER WHEEL, 3" DIA 1 1/2" W
6	G0085	1	GASKET, SILICONE RUBBER HC
7	FB57021410	1	INTAKE COVER, HC36 AIR DIS BOX
8	FB57002902	1	BLOWER MTG PLATE
9	FSA113	1	FAN SUPPORT
10	SCR118	2	SCREW, 6-32 X 5/8 SLTD RD
11	FB57021510	1	INTAKE BODY AIR DIST BOX HC36
12	SCR354	6	SCREW, 8 X 1/2 PHIL PAN
13	TP0021	0.63 FT	TAPE, ARMAFLEX 1/8 X 3/4 X 50'
14	RIV171	6	RIVET, 1/8 ALUM (.187-.250)

Figure 11. Control Panel



HC36/HC72 CONTROL PANEL

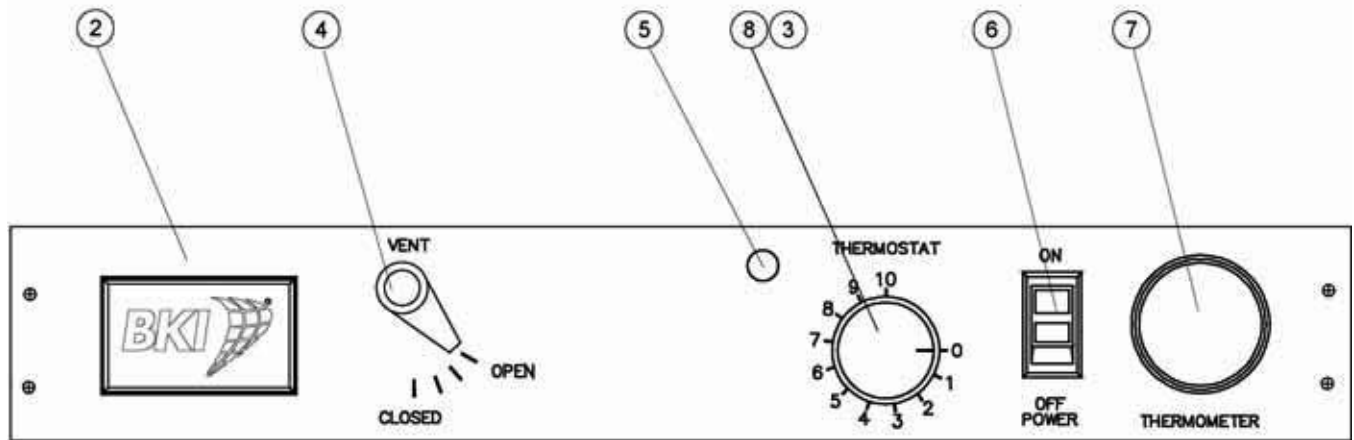

HC36/HC72 VENTED CONTROL PANEL

Table 11. Control Panel Parts

ITEM #	PART #	QTY	DESCRIPTION
1	N0431 or N0432	1	DECAL, CONTROL PANEL HC36 or DECAL, CONTROL PANEL HC72
2	N0447 or N0448		DECAL, HC36 VENTED CONTROL PNL or DECAL, HC72 VENTED CONTROL PNL
3	K0041	1	KNOB, BLACK W/BUSHING
4	K0045	1	KNOB, BLK
5	PL0004	1	PILOT LIGHT, ROUND 250V
6	S0102 or S0107	1	SWITCH, RCKR SPST W/LITE 250V or SWITCH, RKR SPST 15A 125V LAMP
7	TG0024 or TG0001	1	THERMOMETER 100-220 F/C 36" CAP. or THERMOMETER 30-300 F/C 72" CAP.
8	T0071	1	THERMOSTAT

Figure 12. Heat Box

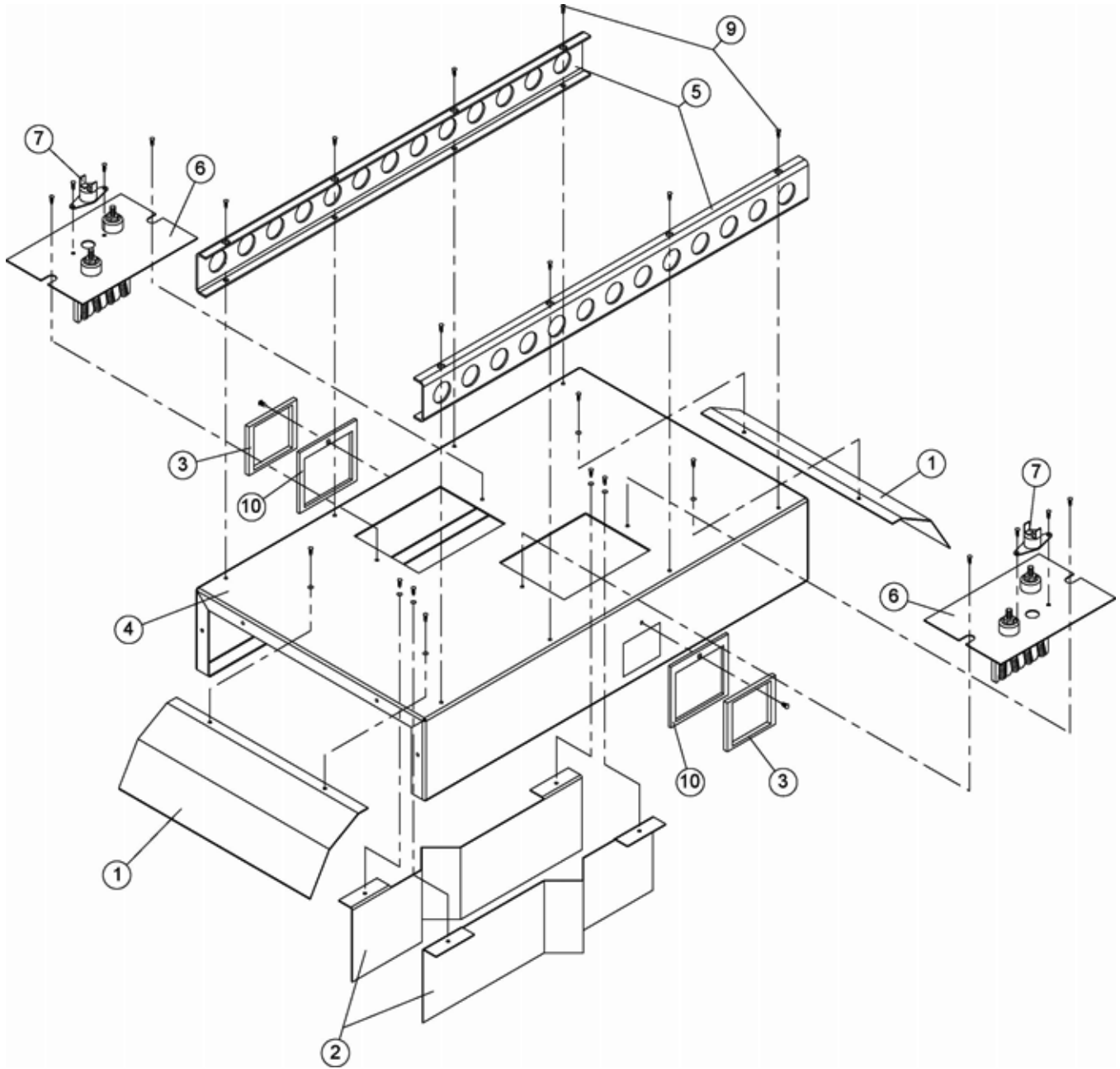

Table 12. Heat Box Parts

ITEM #	PART #	QTY	DESCRIPTION
1	FB57001610	2	AIR DEFLECTOR
2	FB57001502	2	AIR BAFFLE
3	G0084	2	GASKET, CLOSED CELL NEOPRENE
4	FB57021310	1	HEAT MODULE DIST BOX HC36
5	FB57021609	2	BRACE, TOP HC36
6	C0287B or C0288B or C0303B or C0304B	2	CALROD, 120V 1000W W/BRACKET or CALROD, 120V 750W W/BRACKET or CALROD, 240V 1000W W/BRACKET or CALROD, 240V 750W W/BRACKET
7	T0074	2	TEMP SENSOR
8	F0155 *	2	BUSHING, BLK 7/8 HEYCO SNAP
9	SCR354	26	SCREW, 8 X 1/2 PHIL PAN
10	FB57022310	2	GASKET RETAINING FRAME, HC36

* - Not shown on drawing.

Figure 13. Power Supply Panel

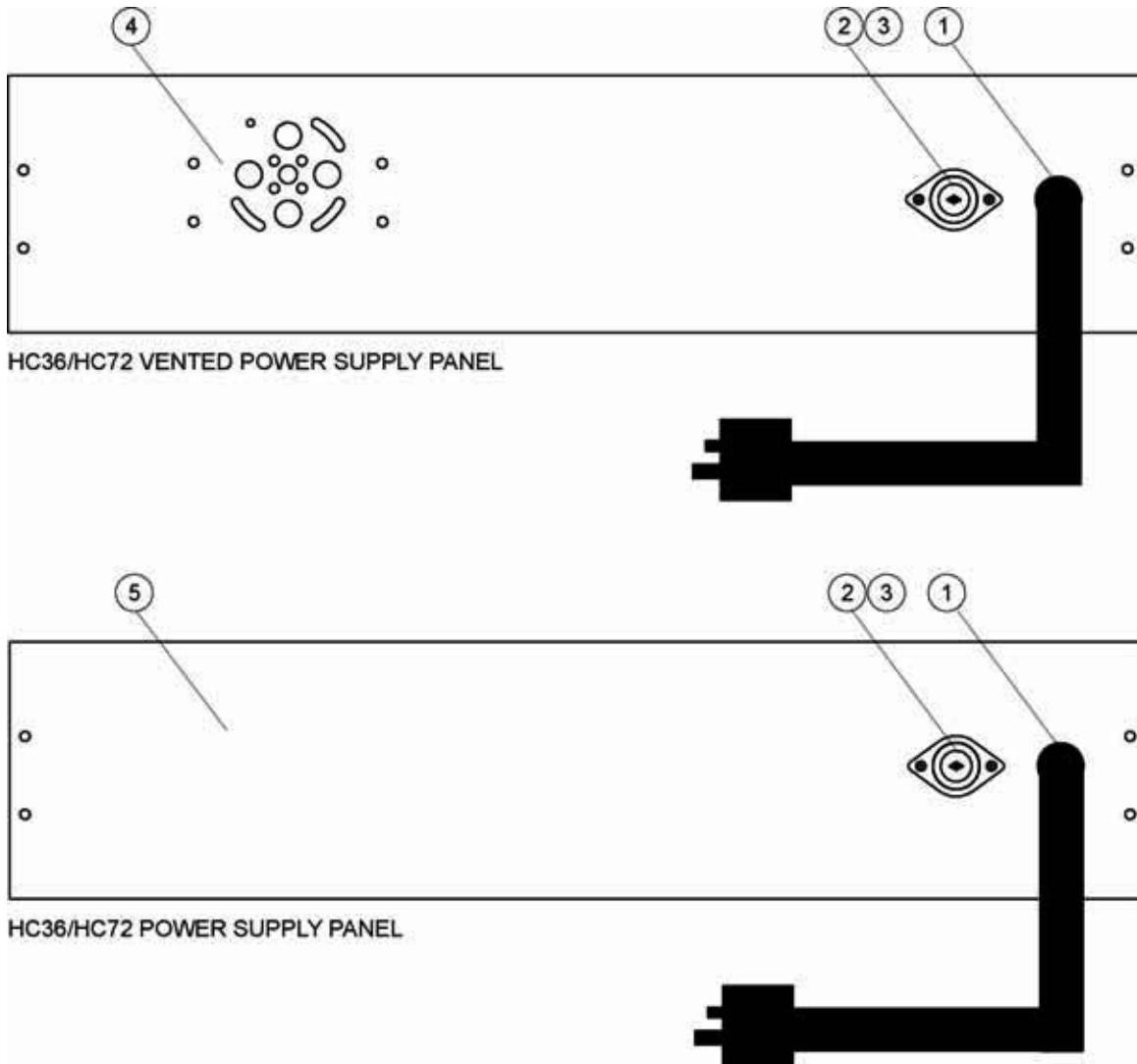

Table 13. Power Supply Panel Parts

ITEM #	PART #	QTY	DESCRIPTION
1	CS0024	1	CORD SET, 12/3 SJTO 8' 30"LEAD
2	FH0001	1	FUSE HOLDER, 15A 300V
3	F0123 or F0124	1	FUSE, 2A SC2 BUSSMAN or FUSE, 4A SC4 BUSSMAN
4	LZ0024	1	POWER SUPPLY PANEL LASER CUT HC
5	FB57021903	1	POWER SUPPLY PANEL, HC36

Figure 14. Tray Rack (HC36)

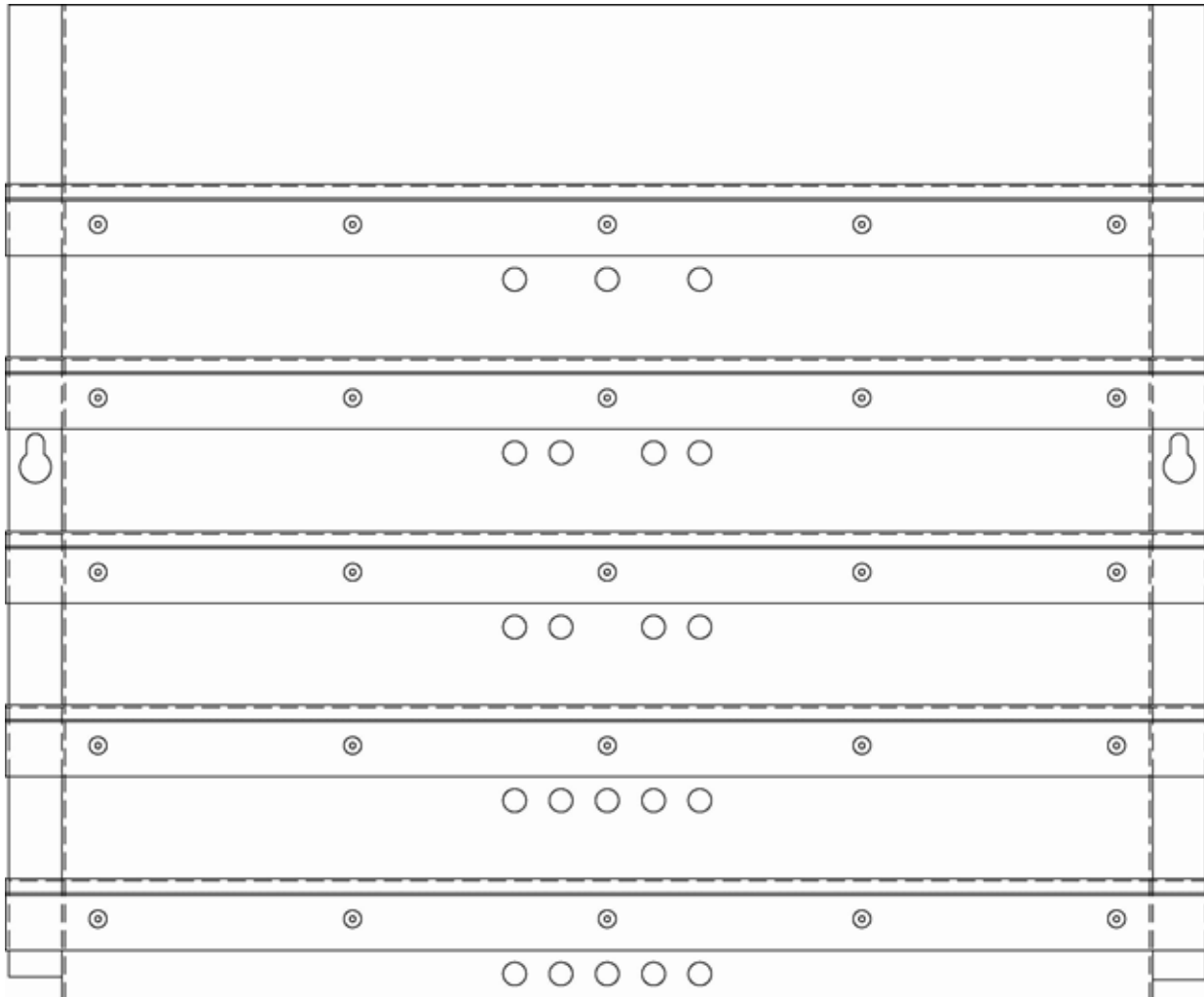

Figure 15. Lower Tray Rack (HC72)

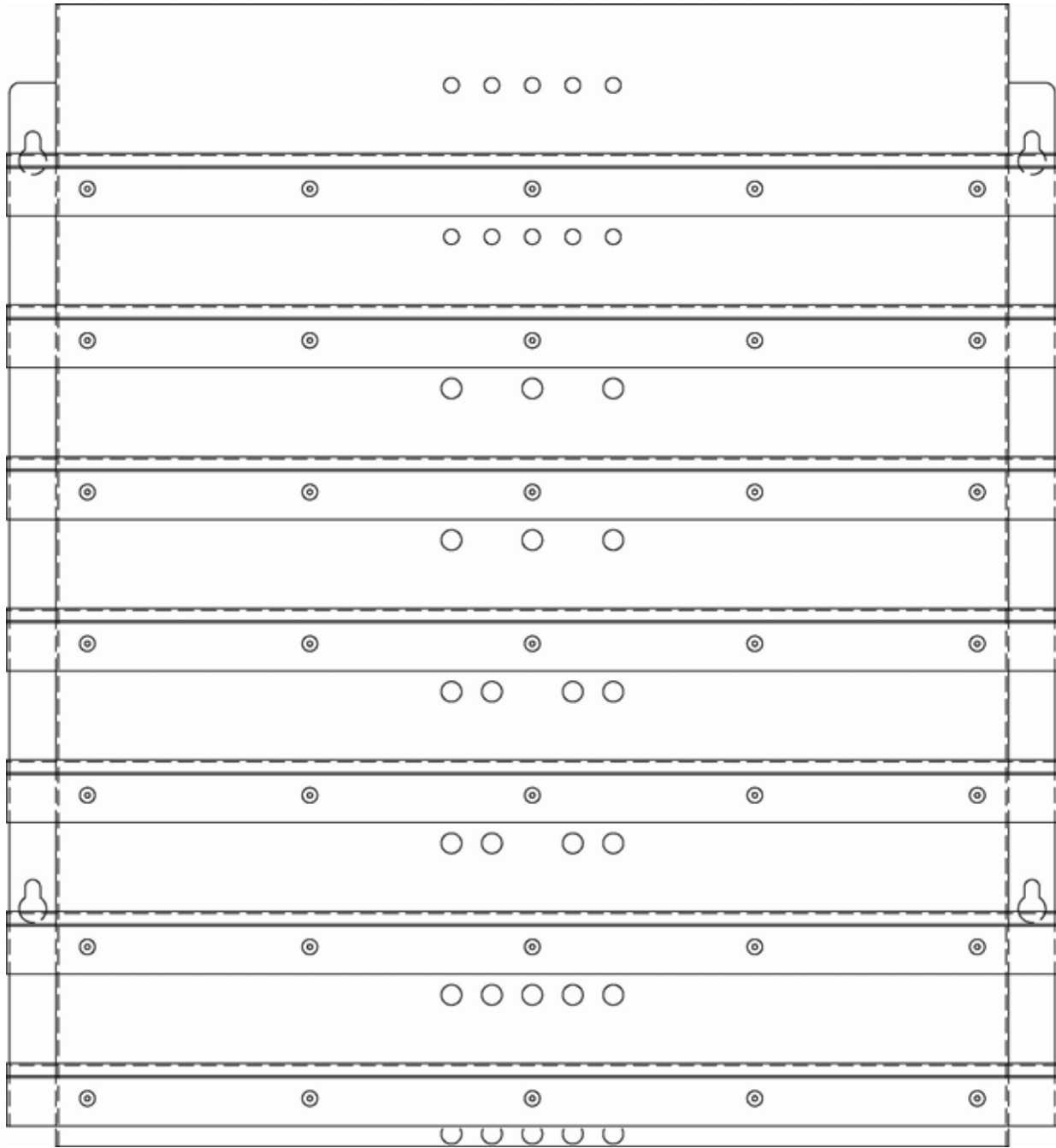
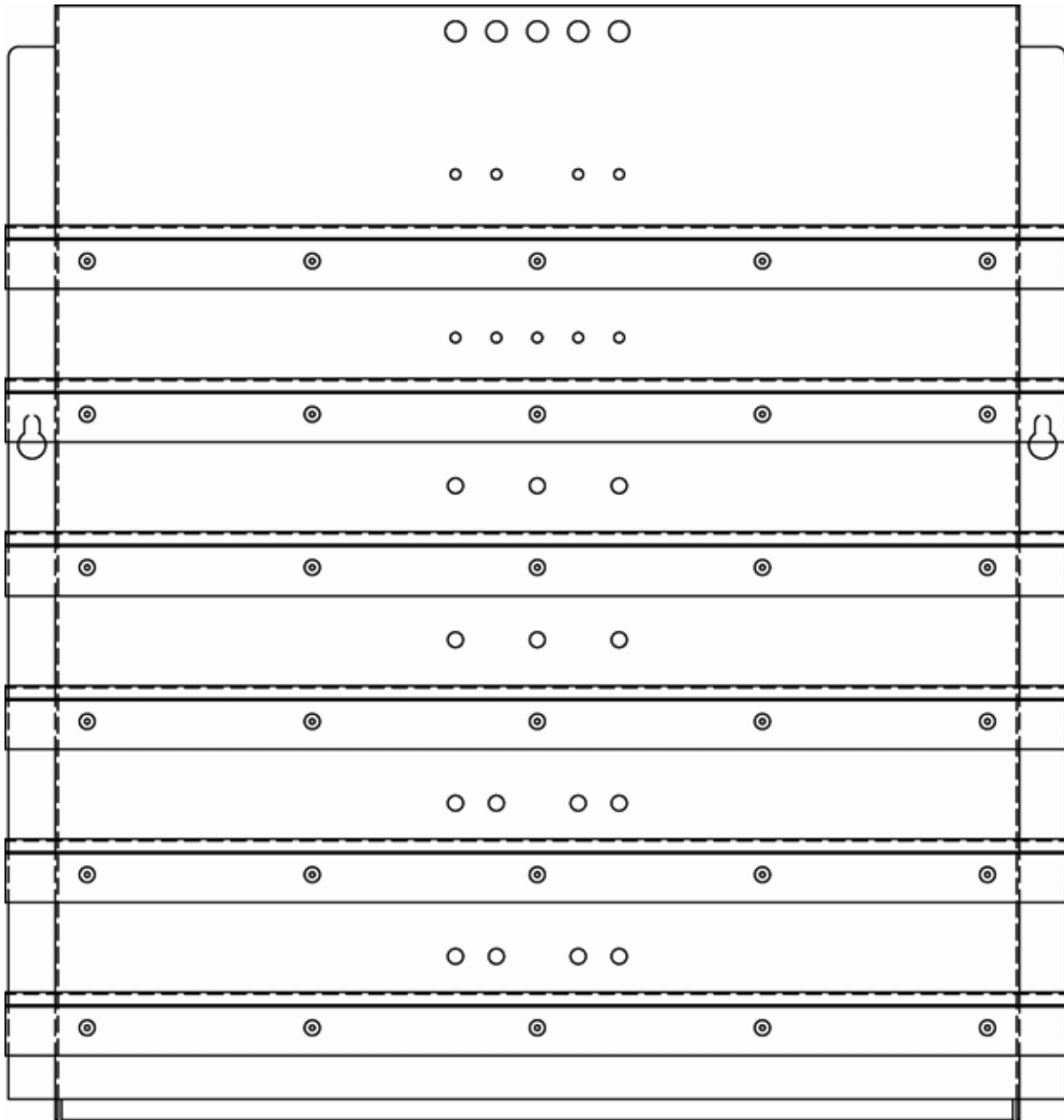





Figure 16. Upper Tray Rack (HC72)



Accessories

PART #	DESCRIPTION	PICTURE
G0052	Insulated Mitt, 13"	
P0057	Pan, Bun Sheet	
R0075	Rack	

Wiring Diagrams

Refer to the table below to find the wiring diagram associated with your unit.

Wiring Diagram	Part #	Figure #
HC36/72 120V/1 Phase	SA57021200	Figure 17
HC36/72 220V/1 Phase	SA57090000	Figure 19
HC36/72 240V/1 Phase (ENGLAND)	SA57023200	Figure 18

Figure 17. HC36/72 120V/1 Phase

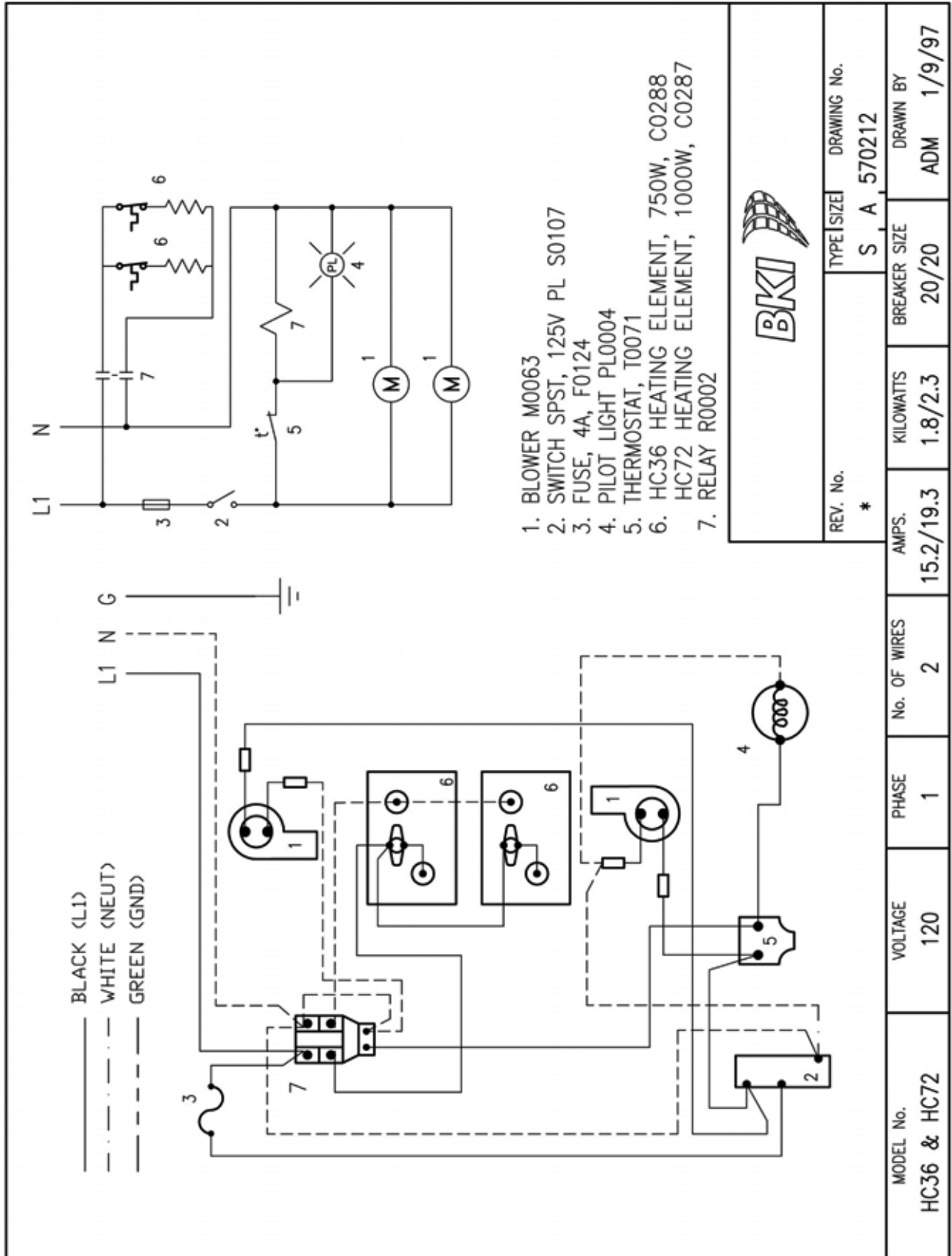

Figure 18. HC36/72 220V/1 Phase

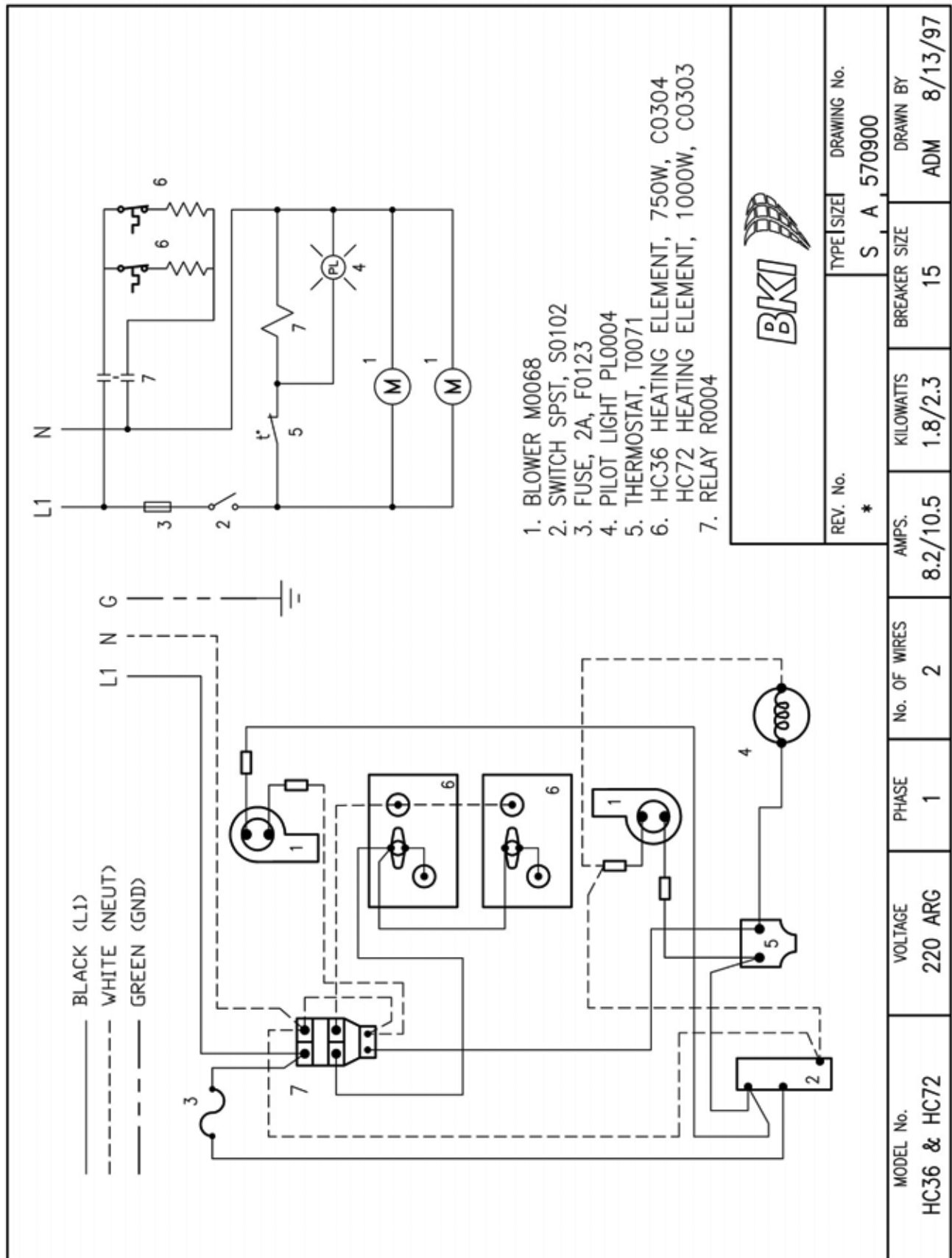
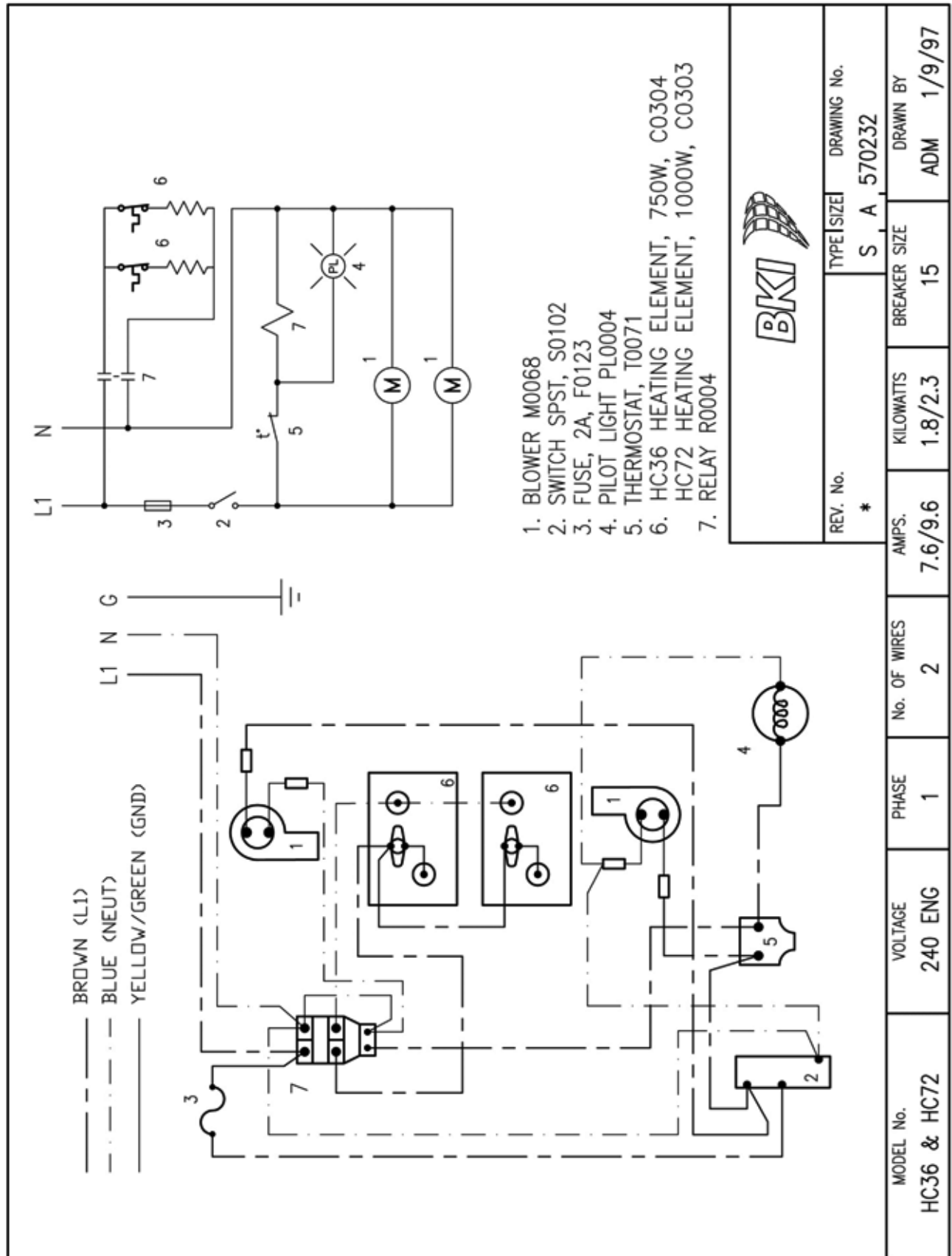

Figure 19. HC36/72 240V/1 Phase (ENGLAND)



Notes



P.O. Box 80400, Simpsonville, S.C. 29680-0400, USA
<http://www.bkideas.com>

Made and printed in the U.S.A
LI0258/0407