

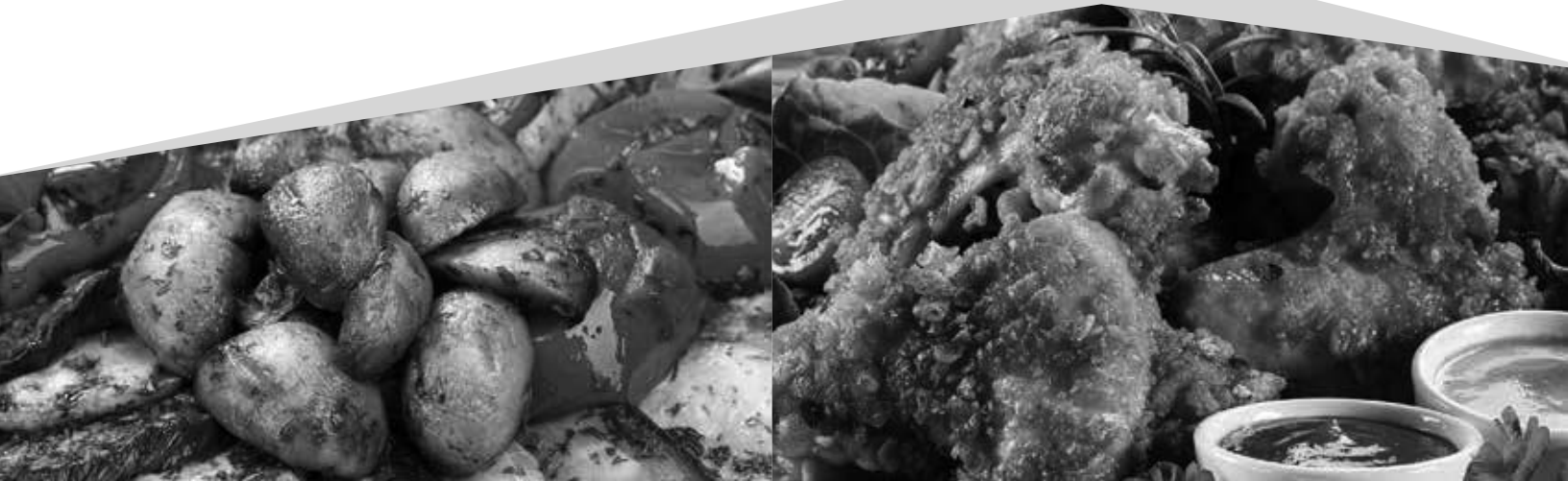

## *Multi - Shelf Merchandiser Series*

**Series: HSS**

**Operation & Service Manual**



## BKI LIMITED WARRANTY

2812 Grandview Drive • Simpsonville, SC 29680 • USA  
(864) 963-3471 • Toll Free: (800) 927-6887 • Fax: (864) 963-5316

WHAT IS COVERED	<p>This warranty covers defects in material and workmanship under normal use, and applies only to the original purchaser providing that:</p> <ul style="list-style-type: none"><li><input type="checkbox"/> The equipment has not been accidentally or intentionally damaged, altered or misused;</li><li><input type="checkbox"/> The equipment is properly installed, adjusted, operated and maintained in accordance with national and local codes, and in accordance with the installation and operating instructions provided with this product.</li><li><input type="checkbox"/> The serial number rating plate affixed to the equipment has not been defaced or removed.</li></ul>
WHO IS COVERED	<p>This warranty is extended to the original purchaser and applies only to equipment purchased for use in the U.S.A.</p>
COVERAGE PERIOD	<ul style="list-style-type: none"><li><input type="checkbox"/> Warranty claims must be received in writing by BKI within one (1) year from date of installation or within one (1) year and three (3) months from date of shipment from the factory, whichever comes first.</li><li><input type="checkbox"/> COB Models: One (1) Year limited parts and labor.</li><li><input type="checkbox"/> COM Models: Two (2) Year limited parts and labor. COM convection ovens also have a two (2) year door warranty.</li><li><input type="checkbox"/> CO1 Models: Two (2) Year limited parts and labor. Five (5) Year limited door warranty.</li><li><input type="checkbox"/> BevLes Products: Two (2) Year limited parts and labor.</li><li><input type="checkbox"/> Warranty period begins the date of dealer invoice to customer or ninety (90) days after shipment date from BKI, whichever comes first.</li></ul>
WARRANTY COVERAGE	<p>This warranty covers on-site labor, parts and reasonable travel time and travel expenses of the authorized service representative up to (100) miles round trip and (2) hours travel time and performed during regular, weekday business hours.</p>
EXCEPTIONS	<p>Any exceptions must be pre-approved in advance and in writing by BKI. The extended door warranty on convection ovens years 3 through 5 is a parts only warranty and does not include labor, travel, mileage or any other charges.</p>
EXCLUSIONS	<ul style="list-style-type: none"><li><input type="checkbox"/> Negligence or acts of God,</li><li><input type="checkbox"/> Thermostat calibrations after (30) days from equipment installation date,</li><li><input type="checkbox"/> Air and gas adjustments,</li><li><input type="checkbox"/> Light bulbs,</li><li><input type="checkbox"/> Glass doors and door adjustments,</li><li><input type="checkbox"/> Fuses,</li><li><input type="checkbox"/> Adjustments to burner flames and cleaning of pilot burners,</li><li><input type="checkbox"/> Tightening of screws or fasteners,</li><li><input type="checkbox"/> Failures caused by erratic voltages or gas suppliers,</li><li><input type="checkbox"/> Unauthorized repair by anyone other than a BKI Factory Authorized Service Center,</li><li><input type="checkbox"/> Damage in shipment,</li><li><input type="checkbox"/> Alteration, misuse or improper installation,</li><li><input type="checkbox"/> Thermostats and safety valves with broken capillary tubes,</li><li><input type="checkbox"/> Freight - other than normal UPS charges,</li><li><input type="checkbox"/> Ordinary wear and tear,</li><li><input type="checkbox"/> Failure to follow installation and/or operating instructions,</li><li><input type="checkbox"/> Events beyond control of the company.</li></ul>
INSTALLATION	<p>Leveling, as well as proper installation and check out of all new equipment - per appropriate installation and use materials - is the responsibility of the dealer or installer, not the manufacturer.</p>
REPLACEMENT PARTS	<p>BKI genuine Factory OEM parts receive a (90) day materials warranty effective from the date of installation by a BKI Factory Authorized Service Center.</p>

Warranty is in lieu of all other warranties, expressed or implied, and all other obligations or liabilities on the manufacturer's part. BKI shall in no event be liable for any special, indirect or consequential damages, or in any event for damages in excess of the purchase price of the unit. The repair or replacement of proven defective parts shall constitute a fulfillment of all obligations under the terms of this warranty.

# Table of Contents

<b>Table of Contents</b> .....	<b>1</b>
<b>Introduction</b> .....	<b>2</b>
Shipping Damage .....	2
Safety Precautions .....	3
Safety Signs and Messages .....	3
Specific Precautions .....	3
Safe Work Practices .....	4
Health And Sanitation Practices .....	6
Food Handling .....	6
Storage Of Raw Meats .....	6
Coding Cooked Foods .....	6
Storage Of Prepared Foods .....	6
<b>Installation</b> .....	<b>7</b>
Floor Model .....	7
Counter Model .....	8
Caster Model .....	8
Wiring .....	8
General Guidelines .....	8
Guidelines for European Appliances .....	8
<b>Operation</b> .....	<b>10</b>
Controls and Indicators .....	10
Power Up and Preheating .....	10
Operational Guidelines .....	11
Unit Shutdown .....	11
Temperature Adjustment .....	12
<b>Maintenance</b> .....	<b>13</b>
Cleaning (Daily) .....	13
Troubleshooting .....	14
<b>Parts Lists</b> .....	<b>15</b>
Exterior Parts .....	15
Shelves .....	17
Blower / Heater Assembly .....	18
Control Parts .....	19
<b>Wiring Diagrams</b> .....	<b>20</b>
<b>Notes</b> .....	<b>34</b>

*BKI Worldwide is a wholly owned subsidiary of Standex International Corporation.*

## Introduction

Your **BKI** HSS is a multi-deck, self-service hot food merchandiser. It utilizes a gentle hot air convection to maintain products at a safe temperature for an extended period of time. The temperature of each heated zone can be controlled independently. The shelves have a marine edge to retain spills and are made of stainless steel for durability and easy cleaning.

The **BKI** name and trademark on this unit assures you of the finest in design and engineering -- that it has been built with care and dedication -- using the best materials available. Attention to the operating instructions regarding proper installation, operation, and maintenance will result in long lasting dependability to ensure the highest profitable return on your investment.

### **NOTICE**

PLEASE READ THIS ENTIRE MANUAL BEFORE OPERATING THE UNIT. If you have any questions, please contact your BKI Distributor. If they are unable to answer your questions, phone the applicable BKI Technical Services Department:

**BKI North America:** (864) 963-3471

**BKI Europe:** (44) 0870 9904242

### **WARNING**

Serious injury, equipment damage or death could result if attempting to install this unit yourself. Ensure that an authorized **BKI** service agent install the oven.

## **Shipping Damage**

Inspect all cartons and crates for damage as soon as they arrive. If damage to cartons or crates is found, or if a shortage is found, note this on the bill of lading (all copies) prior to signing.

If damage is found when the equipment is opened, immediately call the carrier and follow up the call with a written report indicating concealed damage to your shipment. Ask for an immediate inspection of your concealed damage item. Packaging material **MUST** be retained to show the inspector from the carrier.

This equipment is carefully packed or crated at our factory. The carrier has assumed responsibility to delivery it safely. If damaged, the owners must file claim with the carrier.

### **WARNING**

Do not place heavy objects on top of the unit or damage could occur. The units are not structurally designed to support excessive external loading.

## Safety Precautions

Always follow recommended safety precautions listed in this manual. Below is the safety alert symbol. When you see this symbol on your equipment, be alert to the potential for personal injury or property damage.

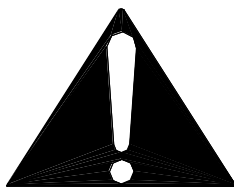

## Safety Signs and Messages

The following Safety signs and messages are placed in this manual to provide instructions and identify specific areas where potential hazards exist and special precautions should be taken. Know and understand the meaning of these instructions, signs, and messages. Damage to the equipment, death or serious injury to you or other persons may result if these messages are not followed.



This message indicates an imminently hazardous situation which, if not avoided, will result in death or serious injury.



This message indicates a potentially hazardous situation, which, if not avoided, could result in death or serious injury.



This message indicates a potentially hazardous situation, which, if not avoided, may result in minor or moderate injury. It may also be used to alert against unsafe practices.



This message is used when special information, instructions or identification are required relating to procedures, equipment, tools, capacities and other special data.

## Specific Precautions



**California Residents Only. This product can expose you to chemicals including chromium, and lead which are known to the State of California to cause cancer and birth defects or other reproductive harm. For more information go to [www.P65Warnings.ca.gov](http://www.P65Warnings.ca.gov).**



### Equipotential Ground Plane

When a high current flows through a conductor, differences in potential appear between the conductor and nearby metallic surfaces near the appliance. As a result, sparks may be produced between the appliance and surrounding metal surfaces. These sparks could cause serious injury, damage, or fire.

**NOTICE****Full Disconnection for IEC / CE Regulations**

In accordance with Local and/or National wiring codes, the installer must provide a means of full disconnection for overvoltage Category III conditions. An IEC approved cord and plug combination will meet this requirement.

Units not provided with a cord and plug do not meet this requirement. In accordance with Local and/or National wiring codes, the installer must provide the means of full disconnection.

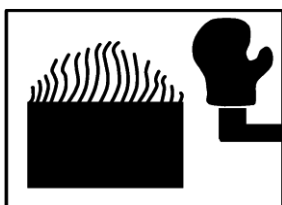
**Safe Work Practices****Wear Safe Clothing Appropriate To Your Job**

Always wear insulated mitts when handling hot products or touching any hot metal surface. You can buy insulated mitts at your local restaurant equipment supply store or from your local **BKI** Distributor.

Always wear non-skid shoes when working around the oven or any other equipment.

Always wear appropriate personal protection equipment during the cleaning process to guard against possible injury.

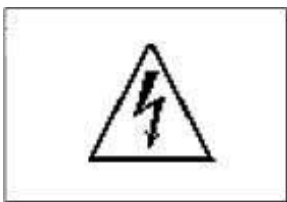
**WARNING – DANGEROUS VOLTAGE**

This equipment uses high voltage. Serious injury can occur if you or any untrained or unauthorized person installs, services, or repairs this equipment. Always Use an Authorized Service agent to Service Your Equipment.

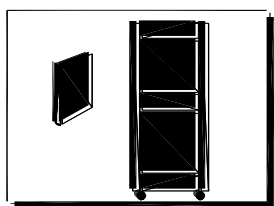
**Keep this manual with the Equipment**

This manual is an important part of your equipment. Always keep it near for easy access. If you need to replace this manual, phone the applicable BKI Technical Services Department:

**BKI North America:** (864) 963-3471

**BKI Europe:** (44) 0870 9904242



**Protect Children**

Keep children away from this equipment. Children may not understand that this equipment is dangerous for them and others.

NEVER allow children to play near or operate your equipment.



**Keep Safety Labels Clean and in Good Condition**

Do not remove or cover any safety labels on your equipment. Keep all safety labels clean and in good condition. Replace any damaged or missing safety labels. Refer to the Safety Labels section for illustration and location of safety labels on this unit. If you need a new safety label, obtain the number of the specific label illustrated on page 5, then phone the applicable BKI Technical Services Department:

**BKI North America:** (864) 963-3471

**BKI Europe:** (44) 0870 9904242

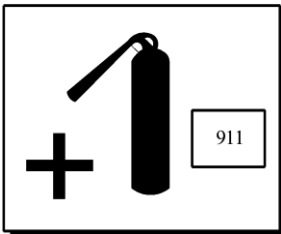

**Be Prepared for Emergencies**

Be prepared for fires, injuries, or other emergencies.

Keep a first aid kit and a fire extinguisher near the equipment. You must use a 40-pound Type BC fire extinguisher and keep it within 25 feet of your equipment.

Keep emergency numbers for doctors, ambulance services, hospitals, and the fire department near your telephone.

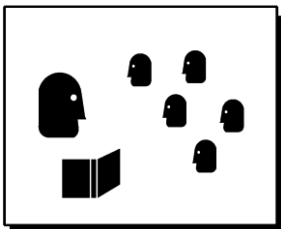

**Know your responsibilities as an Employer**

- Make certain your employees know how to operate the equipment.
- Make certain your employees are aware of the safety precautions on the equipment and in this manual.
- Make certain that you have thoroughly trained your employees about operating the equipment safely.
- Make certain the equipment is in proper working condition. If you make unauthorized modifications to the equipment, you will reduce the function and safety of the equipment.

## Health and Sanitation Practices

**BKI** hot food merchandisers are manufactured to comply with health regulations and are tested and certified to NSF and FSA standards. You must operate the equipment properly, using only quality products and use meat thermometers to insure meats are thoroughly cooked.

## Food Handling

- Wash hands thoroughly in warm, soapy water after handling raw poultry or meats.
- Clean and sanitize all utensils and surfaces that have been in contact with raw products. Clean and sanitize the meat forks or baskets between cooking.
- **Never** place cooked meats on the same surfaces used to prepare raw meats, unless the area has been thoroughly cleaned and sanitized.

## Storage of Raw Meats

- Designate an area or shelf strictly for the storage of all raw meats to be used.
- Raw product must always be stored at temperatures below 38° F. (3° C.).
- **Never** store or mix raw foods above cooked foods, as this is a health hazard. The drippings from raw foods contaminate cooked or processed foods.
- All chicken and chicken parts to be stored overnight must be thoroughly iced down and refrigerated.

## Coding Cooked Foods

All products cooked during the day should be sold the same day.

**NOTE:** It is not the intent of the rotisserie program to have unsold merchandise at the end of the cooking day. Follow your company's procedures for the handling of any leftover product.

## Storage of Prepared Foods

- Cold foods should be kept at or below 38° F. (3° C.).
- Hot foods must be maintained to meet local health codes, usually a minimum 145° F. (63° C.).



## Installation

### **WARNING**

Serious injury, equipment damage or death could result if attempting to install this unit yourself. Ensure that an authorized **BKI** service agent install the unit.

Move the unit as close as possible to its permanent location before moving it off of the shipping pallet. Make certain there are no separately packed accessories before discarding packaging material.

### **Floor Model**

Follow the procedure below to level the unit and mount the kick plates.

1. Slide kick plates, ends first, between the base frame and outer panels. Secure in raised position with tape. Make sure that the end kick plates fit behind the front and rear kick plates.
2. Using a carpenter's level on the lowest shelf, level the unit by adjusting the leg levelers at the corners of the unit. Raise the low end of the unit to level it, do not lower the high end. Check for level side-to-side and front-to-back.
3. Remove the tape from the kick plates and make certain that the kick plates are flush to the floor.
4. Drill 9/64" [3.5 mm] diameter holes in the base frame to match the pre-drilled holes in the kick plates.
5. Attach the kick plates to the base frame with the #8x1/2" black sheet metal screws provided (SCR355).
6. Seal kick plates to floor using a silicone-type sealant (Dow Corning RTV #732 or equivalent).

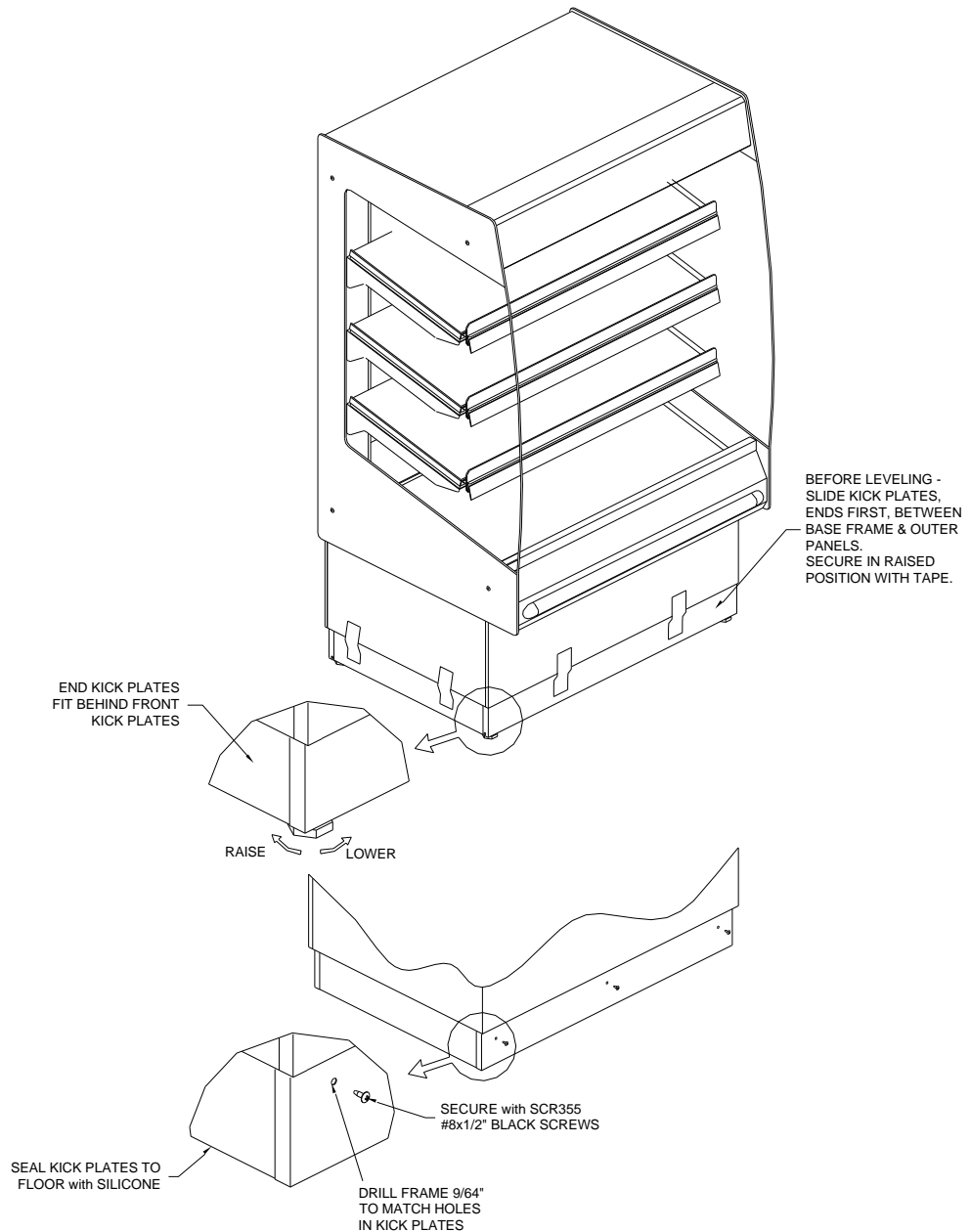

**Figure 1. Floor Model – Leveling & Kick Plate Mounting**

## Counter Model

Counter mounted units must be mounted on a level surface that can support the weight of the unit and its contents. Use a carpenter's level to level the unit.

These units are to be sealed to the counter if required by local health codes. Seal the perimeter of the units to the counter using a silicone-type sealant (Dow Corning RTV #732 or equivalent).

## Caster Model

Caster mounted units must be moved to a permanent location and the two swivel casters locked before using.

**WARNING** Do not place heavy objects on top of the unit or damage could occur. The units are not structurally designed to support excessive external loading.

## Wiring

**WARNING** Electrocutation, equipment failure or property damage could result if an unlicensed electrician performs the electrical installation. Ensure that a licensed electrician perform the electrical installation in accordance with local codes, or in the absence of local codes, with the National Electrical Code, ANSI NFPA 70-20XX.

This unit, when installed by an authorized BKI service agent, must be wired for use in accordance with all applicable local, state, and federal codes. For specific electrical requirements and connections refer to the wiring diagram attached to the unit or provided in the Service Manual.

## General Guidelines

- In the absence of local codes refer to the latest edition of one of the following:
  - National Electrical Code, ANSI/NFPA 70-20XX (USA) which can be obtained from:

The National Fire Protection Association  
Batterymarch Park  
Quincy, MA 02269

- I.E.E. Wiring Regulations (Europe)
- Verify that the power supply conforms to the electrical rating listed on the oven data plate.
- Ensure that the appliance is grounded (earthed).

## Guidelines for European Appliances

**Note:** - A method of disconnection from the main supply having a contact separation of least 3mm in all poles must be incorporated in the fixed wiring.

- It is recommended that an **R.C.D.** with a 30ma trip and contact rating to suit the appliance current be installed adjacent to the appliance.
- Type C/ 3 circuit breakers or appropriate rated fuses are recommended for installation at the supply end.

**Note:** - surge currents are present when this appliance is switched on from cold.

- Industrial plugs and sockets must comply with BS 4343/EN60309 (IEC309.2/CEE17).

**Supply Cable Connection**

- It is recommended that the power supply cable shall be an oil resistance sheathed flexible cable to BS 6007 (code designation HO7 RN-F).
- It is required that the power supply cable connection to the appliance terminal block, the earth conductor is to be made at least 50mm longer than the length of the live (L) and neutral (N) conductors so that if the supply cable is strained the earth conductor is the last to become disconnected.
- To gain access to the control panel and mains block connection, remove the 4-side panel securing screws on the drive side of the oven.
- The mains block is sited toward the bottom right hand side of the control box. Cable entry is provided through the base of the oven.
- Refer to the mains wiring diagram for correct connection.

## Operation

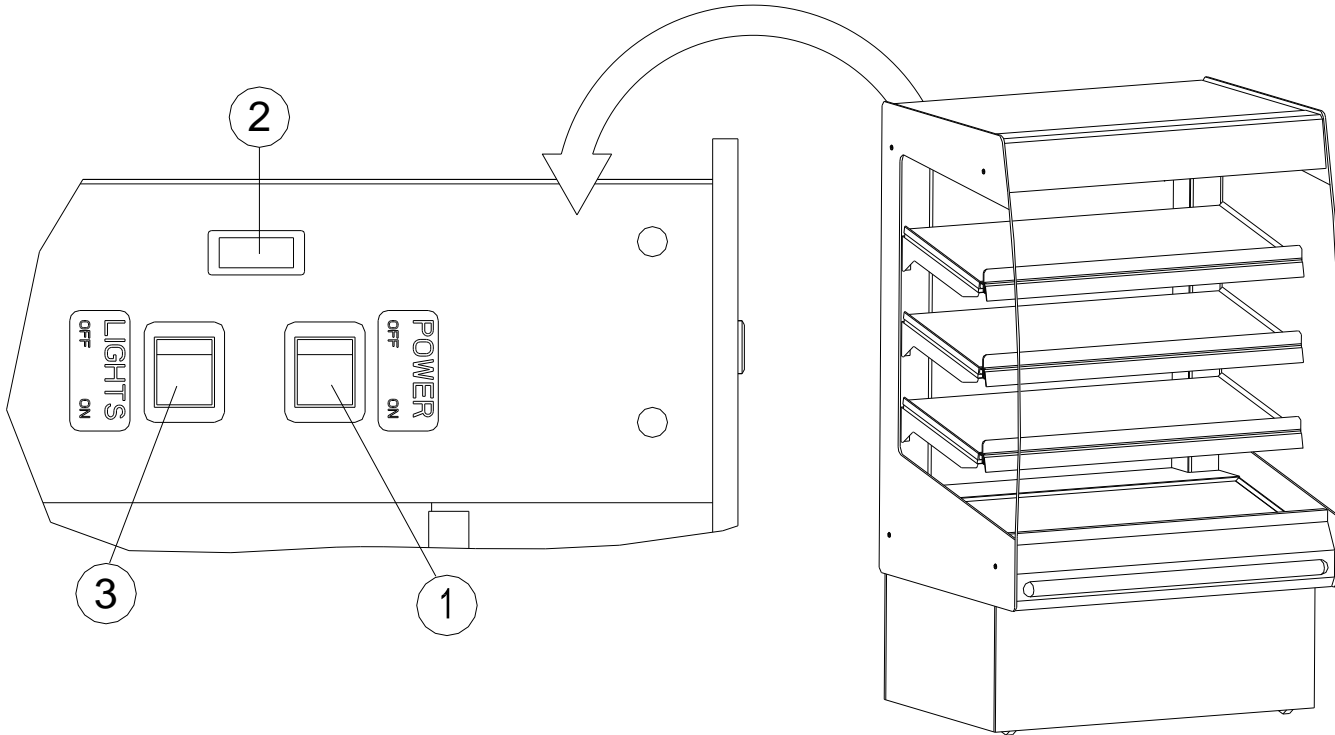

Figure 2. Main Power & Light Switches

## Controls and Indicators

Item #	Description	Function
1	Main Power Switch	Turns power to the entire unit on or off. When placed in the on position, the unit heats to the preset temperature. When placed in the off position, power is removed from the entire unit.
2	Main Power Isolator Light	This light illuminates to indicate that power is being applied to the unit from the Main Power Isolator (Circuit Breaker).
3	Light Switch	Turns power to the lights on or off. Operates only when the Main Power Switch is placed in the on position.

## Power Up and Preheating

1. Ensure that the power supply cord is connected to an appropriate power receptacle.
2. Place the Main Power Switch in the ON position.
3. Place the Light Switch in the ON position.
4. **Allow the unit to preheat for a minimum of 30 minutes before loading it with product.**

## Operational Guidelines

*Unit is intended for pre-package food products only.*

*All food products should be preheated to 70°C (160°F) minimum before being placed in the unit.*

Only use product packaging suitable for the application.

Do not stack product packages on the shelf. Bottom of all product packages must be in contact with shelf service.

Maintain a minimum 50 mm [2 in.] space between the top of the product package and the bottom of the shelf above it.

Measure the internal temperature of the food products hourly with a food thermometer.

Check Federal and State Health and Sanitation Regulations for internal temperature required for holding cooked foods for sale. Maintaining these temperatures often tends to allow continued cooking of certain products. Therefore, smaller amounts of bulk foods should be displayed at non-peak periods and the unit refilled as needed.

Foods held for long periods of time are more difficult to maintain at proper temperature. Also, freshness and product quality diminish if foods are held too long. Most areas of the country have sanitation regulations governing how long foods can be held. Make certain to check with your local authorities.

## Unit Shutdown

1. Remove product from the unit.
2. Place the Main Power Switch in the OFF position.
3. Place the Light Switch in the OFF position.
4. After the unit has cooled down, remove any residue from the shelves and clean the unit thoroughly with mild soapy solution.
5. Clean and polish glass with a good quality glass cleaner.

### CAUTION

DO NOT FLOOD! Use only enough solution the clean surface. Water or solution must not drip down into base.

Never use ammonia based cleaners, abrasive cleansers or scouring pads.

### Temperature Adjustment

The temperature of each shelf's surface is individually controlled via an adjustable thermostat. All of the thermostats are preset at the factory. It may be necessary to adjust the controls due to the food product type or store ambient conditions.

Remove power from the unit before adjusting the thermostats.

**⚠ DANGER** Failure to remove power from this unit may cause severe electrical shock. This unit may have more than one disconnect switch.

The thermostats for the intermediate shelves are accessed by removing the lamp guard and lamp then the cover on the face of the wireway below each shelf. The thermostat for the base warmer is accessed by removing the cover on the lower back of the unit.

Temperature setting is indicated by the three holes in the thermostat mount. Refer to Figure 2 below. Adjust the temperature setting of each thermostat up or down as required. It is recommended that the temperature setting not be adjusted more than 5°C (8° F).

After adjustment verify the temperature settings by monitoring the internal temperature of the food products. The temperature should be adjusted to the lowest possible setting that will maintain the proper product temperature.

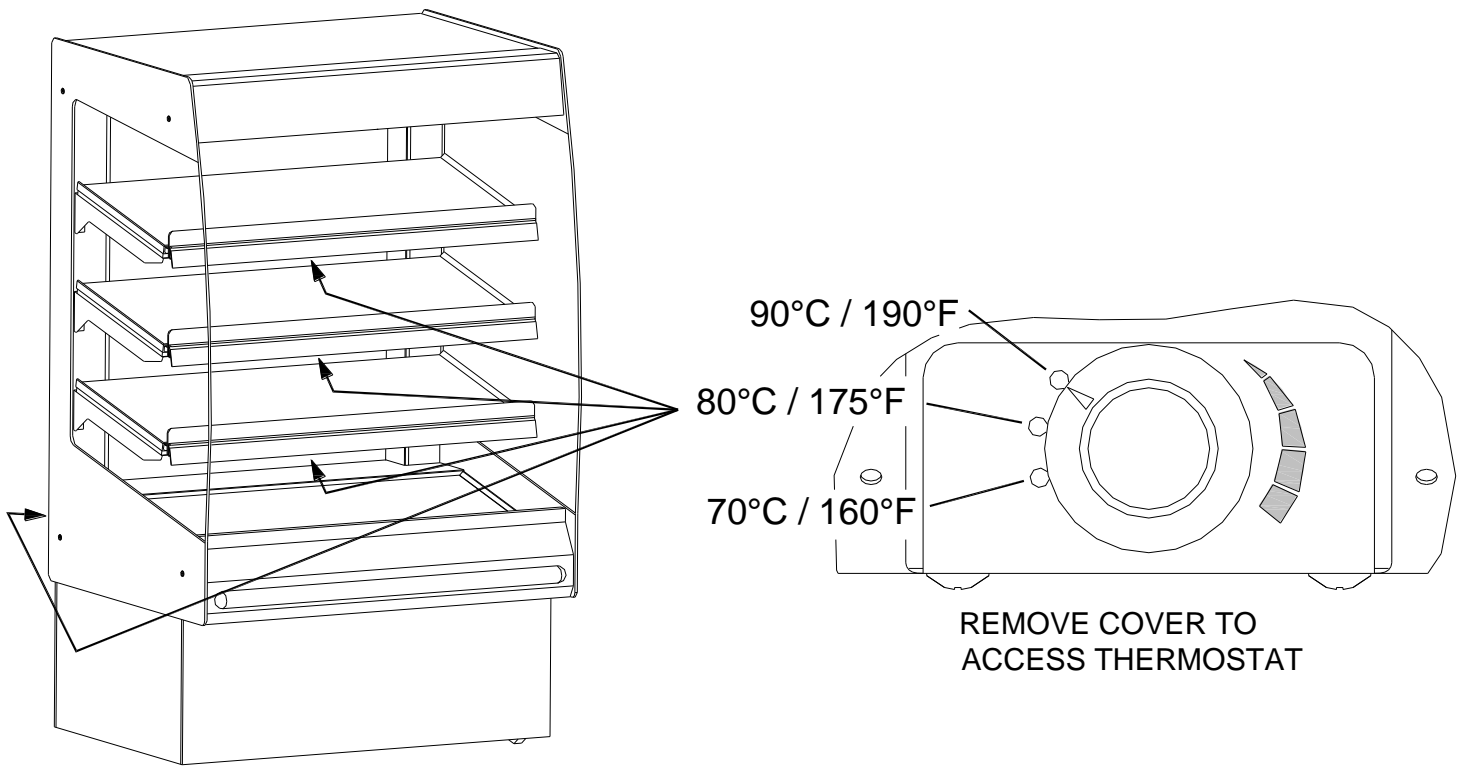

Figure 3. Thermostat Adjustment

---

## Maintenance

### *Cleaning (Daily)*

Cleaning is not only necessary for sanitary reasons, but will increase sales appeal and maximize operating efficiency of the unit.

**⚠ DANGER**

Failure to remove power from this unit may cause severe electrical shock. This unit may have more than one disconnect switch.

**⚠ CAUTION**

Always wear appropriate personal protection equipment during the cleaning process to guard against possible injury.

Never use ammonia based cleaners, abrasive cleansers or scouring pads. These may damage the unit's finish. Use only a mild soap and water solution.

DO NOT USE OVEN CLEANER on this machine. Caustic cleaners can cause damage to the unit.

DO NOT FLOOD! Use only enough solution to clean the surface. Water or solution must not drip down into base.

This appliance is not intended to be cleaned with a water jet. Never steam clean or get excess water in the interior of the cabinet as this can damage unit.

1. Remove product from the unit.
2. Place the Main Power Switch circuit breaker in the OFF position.
3. Place the Light Switch in the OFF position.
4. After the unit has cooled down, remove any residue from the shelves and clean the unit thoroughly with mild soapy solution.
5. Apply a soft, damp cloth with soapy water to the polycarbonate shelf risers. **NOTE:** DO NOT use glass cleaner or paper towels on the polycarbonate shelf risers as they may scratch the surfaces.
6. Clean and polish glass with a good quality glass cleaner.

## Troubleshooting

Problem	Cause	Possible Solution
Unit will not turn on. Main Power Isolator Light is not lit.	Unit power plug disconnected (where applicable).	Plug unit into mating receptacle.
	Problem with building power supply	Check circuit breaker at building power panel. If problem persists, contact BKI service agent for corrective action.
	Fuse in power cord plug is blown (British units only).	Contact BKI service agent for corrective action.
Unit will not turn on. Main Power Isolator Light is lit.	Defective contactor.	Contact BKI service agent for corrective action.
	Defective rocker switch	Contact BKI service agent for corrective action.
Air curtain is weak or non-existent.	Block air curtain discharge.	Remove any items blocking the air curtain discharge. Make certain no signage is obstructing discharge.
	Defective fan(s)	Contact BKI service agent for corrective action.
A shelf does not maintain product temperature.	Shelf thermostat setting is too low.	Contact BKI service agent for corrective action.
	Defective heating element(s).	Contact BKI service agent for corrective action.
A shelf does not heat to temperature.	Defective thermostat.	Contact BKI service agent for corrective action.
	Defective heating element(s).	Contact BKI service agent for corrective action.
A shelf overheats.	Defective thermostat.	Contact BKI service agent for corrective action.
Lights do not illuminate when switch is on.	Blown fuse.	Contact BKI service agent for corrective action.
	Defective bulb.	Contact BKI service agent for corrective action.
	Defective ballast.	Contact BKI service agent for corrective action.



## Parts Lists

Use the information in the section to identify parts. To order parts, call your local **BKI** sales and service representative. Before calling, please note the model and serial numbers on the rating tag affixed to the unit.

### Exterior Parts

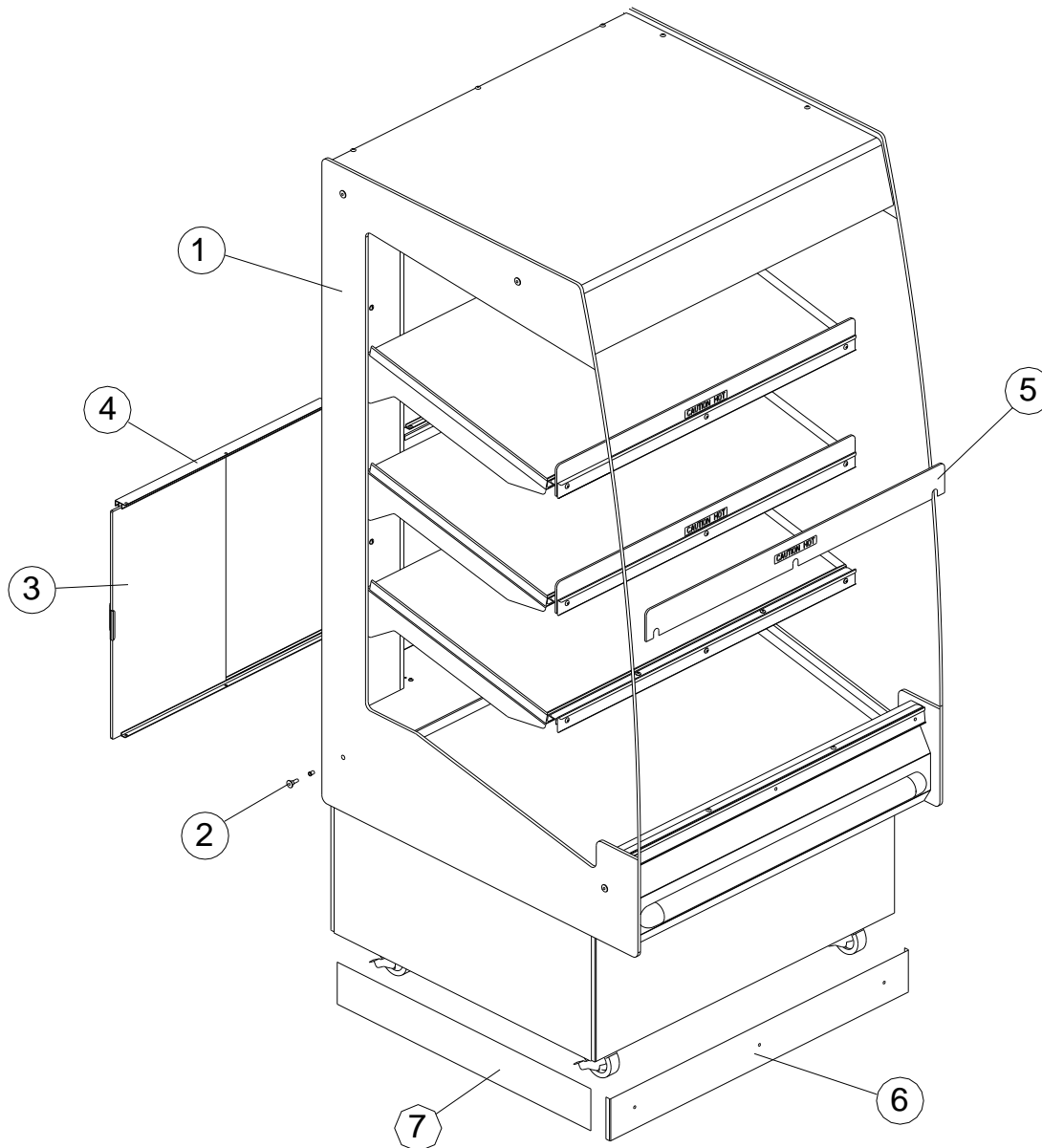

Table 1. Exterior Parts

ITEM#	MODEL#	PART #	QTY	DESCRIPTION
1	HSS-2T	GL0425G	1	LH End Glass, Gray, HSS-2T
		GL0424G	1	RH End Glass, Gray, HSS-2T
	HSS-3T & 4S	GL0422M	1	LH End Glass, Black, HSS-3T & 4S
		GL0422G		LH End Glass, Gray, HSS-3T & 4S
		GL0423M	1	RH End Glass, Black, HSS-3T & 4S
		GL0423G		RH End Glass, Gray, HSS-3T & 4S
	HSS-4T & 5T	GL0420M	1	LH End Glass, Black, HSS-4T & 5T
		GL0420G		LH End Glass, Gray, HSS-4T & 5T
		GL0421M	1	RH End Glass, Black, HSS-4T & 5T
		GL0421G		RH End Glass, Gray, HSS-4T & 5T
2	ALL	BLT248	8	Bolt, 1/4"-20 Joint, Black
		B0233	8	Bearing, Cylinder
3	HSS4-2T	AN7003700S	1	LH Inner Service Door
		AN7003710S	1	RH Outer Service Door
	HSS3-3T & 4S	AN7003720S	4	Service Door, Lexan
	HSS3-4T & 5T	AN7003730S	4	Service Door, Lexan
	HSS4-3T & 4S	AN7003740S	4	Service Door, Lexan
	HSS4-4T & 5T	AN7003750S	4	Service Door, Lexan
4	HSS3-3T & 4T	MB70034000	2	Door Track, Set (top & Bottom)
	HSS4-3T & 4T	MB70034100	2	Door Track, Set (top & Bottom)
	ALL	SCR268	12	Screw, #8 x 1/2" Flat Head
5	HSS2	R0177	2, 3 or 4	Shelf Riser
	HSS3	R0181	2, 3 or 4	Shelf Riser
	HSS4	R0178	2, 3 or 4	Shelf Riser
	ALL	N0594	2, 3 or 4	Decal, Caution Hot
6	HSS4-2T	FB70005601	1	Front Kick Plate, Bright SSTL
		FB70005701	1	Rear Kick Plate, Bright SSTL
	HSS2-3T, 4S, 4T & 5T	FB70036451	2	Front & Rear Kick Plate, Black
	HSS3-3T, 4S, 4T & 5T	FB70036551	2	Front & Rear Kick Plate, Black
	HSS4-3T, 4S, 4T & 5T	FB70036651	2	Front & Rear Kick Plate, Black
7	HSS4-2T	FB67636301	1	Left End Kick Plate, Bright SSTL
		FB67636401	1	Right End Kick Plate, Bright SSTL
	ALL OTHERS	FB70036351	2	End Kick Plate, Black

### Shelves

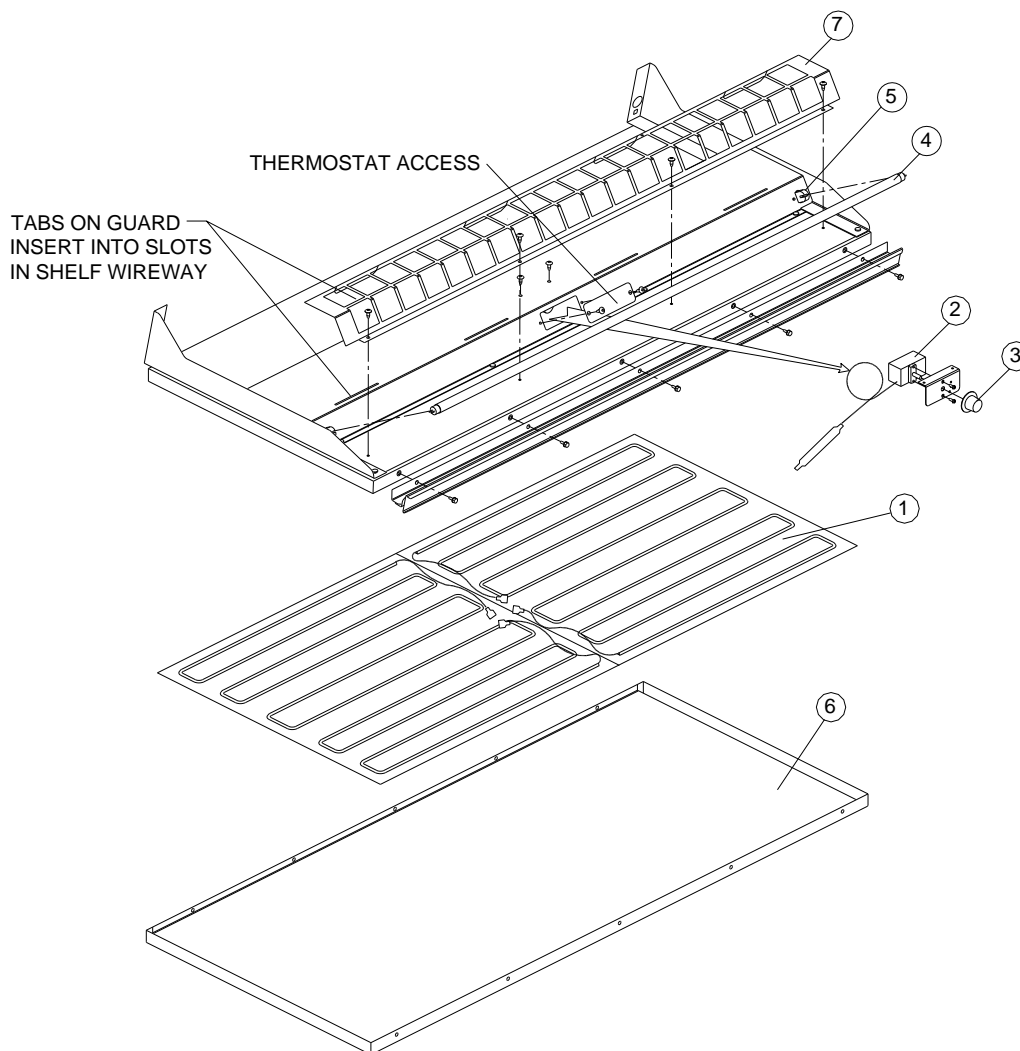
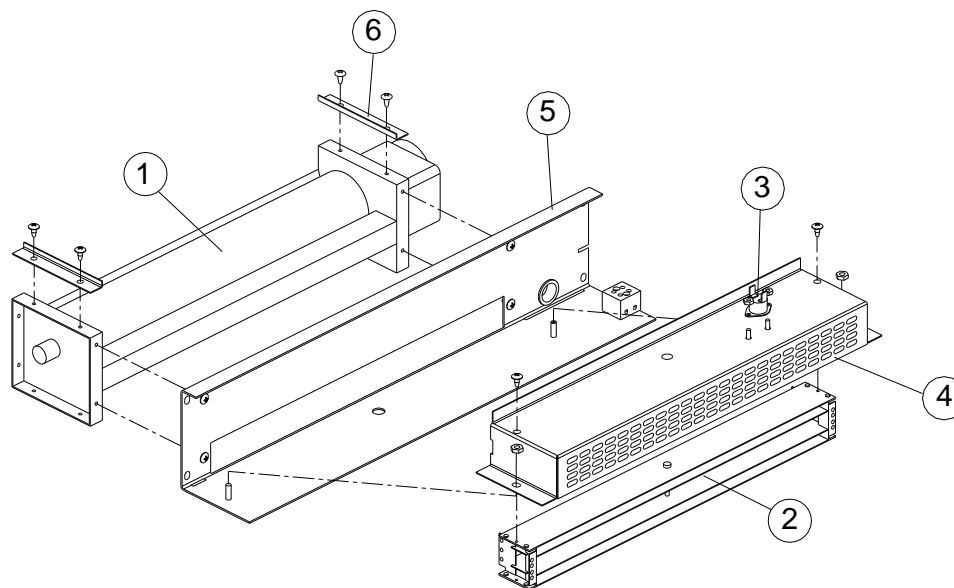

Table 2. Shelf Parts

ITEM#	MODEL#	PART #	QTY	DESCRIPTION
1	HSS2	C0157	1	Heating Element, 300W, 208V
		C0158	1	Heating Element, 300W, 230V
	HSS3	C0763	1	Heating Element, 450W, 208V
		C0762	1	Heating Element, 450W, 230V
	HSS4	C0157	2	Heating Element, 300W, 208V
		C0158	2	Heating Element, 300W, 230V
2	ALL	T0106	1	Thermostat, 85-230F
		TP0040	6"	Foil Tape, 3" Wide
3	ALL	K0049	1	Knob, Thermostat
4	HSS2	FL0047	1	Lamp, Coated Fluorescent, F14T5
	HSS3	FL0044	1	Lamp, Coated Fluorescent, F21T5
	HSS4	FL0045	1	Lamp, Coated Fluorescent, F28T5
5	ALL	LH0025	2	Lampholder, T5
6	HSS2	WB70003700	1	Shelf Top, HSS2
	HSS3	WB70028900	1	Shelf Top, HSS3
	HSS4	WB70003800	1	Shelf Top, HSS4
7	HSS2	FB70025103	1	Lamp Guard, Shelf
	HSS3	FB70030103	1	Lamp Guard, Shelf
	HSS4	FB70025203	1	Lamp Guard, Shelf

**Blower / Heater Assembly****Table 3. Blower / Heater Assembly Parts**

ITEM#	MODEL#	PART #	QTY	DESCRIPTION
1	HSS2-3T, 4S, 4T &5T	EN7003680S	1	Fan, 368 mm, 230V, Capacitor Type
	HSS3-3T, 4S, 4T &5T	EN7003690S	2	Fan, 306 mm, 230V, Capacitor Type
	HSS4-3T, 4S, 4T &5T	EN7003680S	2	Fan, 368 mm, 230V, Capacitor Type
	HSS4-2T	EN7003670S	2	Fan, 368mm, 230V, Shaded Pole Type
	ALL	SCR004	4	Screw, #8 x 3/8" Philips Head
2	HSS2-3T, 4S, 4T &5T	C0349	1	Heating Element, 2 x 925W, 230V
	HSS3-3T, 4S, 4T &5T	C0761	2	Heating Element, 2 x 750W, 230V
	HSS4-3T, 4S, 4T &5T	C0349	2	Heating Element, 2 x 925W, 230V
	HSS4-2T	C0349	2	Heating Element, 2 x 925W, 230V
	ALL	SCR004	2	Screw, #8 x 3/8" Philips Head
3	ALL	T0107	1	Thermostat, 280F, N.O.
	ALL	SCR117	2	Screw, #6-32 x 3/8" Phillips Head
	ALL	NUT262	2	Nut, #6-32 Lock
4	HSS2-3T, 4S, 4T &5T	FB70017503	1	Upper Duct, Heater
	HSS3-3T, 4S, 4T &5T	FB70027703	2	Upper Duct, Heater
	HSS4-3T, 4S, 4T &5T	FB70017503	2	Upper Duct, Heater
	HSS4-2T	FB70017503	2	Upper Duct, Heater
	ALL	NUT286	2	Nut, #10-32 Keps
5	HSS2-3T, 4S, 4T &5T	FB70034218	1	Mount, Blower & Heater
	HSS3-3T, 4S, 4T &5T	FB70034318	2	Mount, Blower & Heater
	HSS4-3T, 4S, 4T &5T	FB70034218	2	Mount, Blower & Heater
	HSS4-2T	FB70034218	2	Mount, Blower & Heater
6	ALL	FB70036009	2	End Flange, Blower
	ALL	SCR004	4	Screw, #8 x 3/8" Philips Head

**Control Parts**

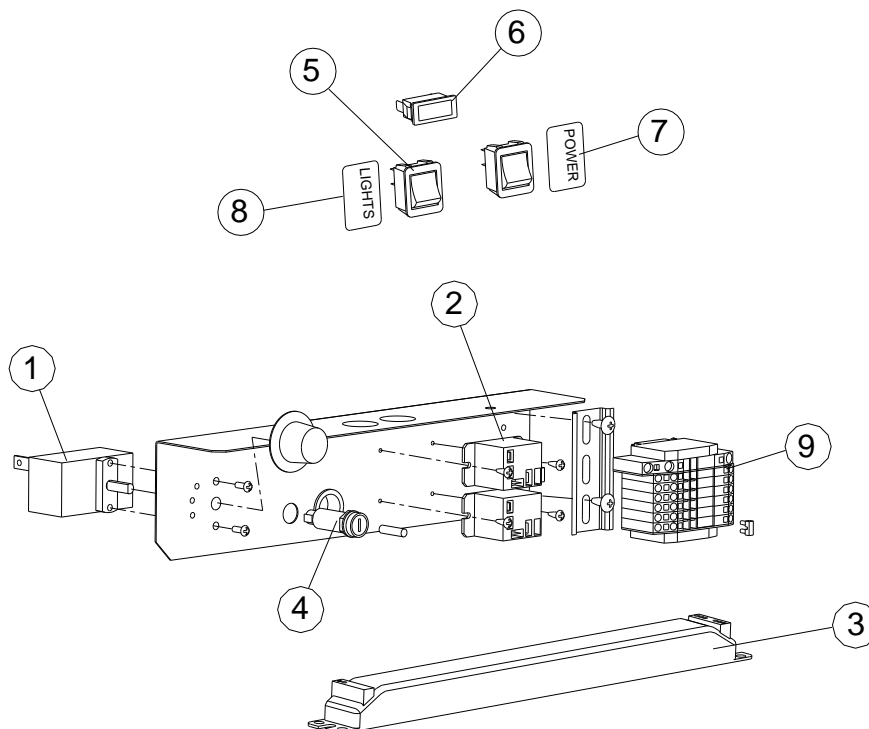

**Table 4. Control Parts**

ITEM#	MODEL#	PART #	QTY	DESCRIPTION
1	ALL	T0106	1	Thermostat. 85-230F
		K0049	1	Knob, Thermostat
2	ALL	TP0040	6"	Foil Tape, 3" Wide
		R0180	2	Relay, SPST, N.O., 240V
3	ALL USA (UL)	SCR004	4	Screw, #8 x 3/8" Philips Head
		B0090	1 or 2	Ballast, 2 x T5 Lamps, UL
		B0091	1 or 2	Ballast, 2 x T5 Lamps, CE
		B0093	1	Ballast, 2 x T5 Lamps, CE
4	ALL	B0094	1	RFI Filter
		FU019UK	1	Fuseholder
		FU004UK	1	Fuse, 2 A
5	ALL	SW040UK	2	Switch, Rocker, DPDT
6	ALL	LI016UK	1	Pilot Light
7	ALL	N0507	1	Decal, Power
8	ALL	N0508	1	Decal, Lights
9	ALL	TB0100	6	Terminal Block Section, 10 AWG
	ALL	TB0102	1	End Plate for above
	ALL	TB0005	1	Terminal Section, Ground
	ALL	TB0004	1	End Plate for above
	ALL	TB0106	2	Jumper, 2 position

# Wiring Diagrams

**COMPONENT LEGEND**

KEY	Part No.	DESCRIPTION
B1	B0090	BALLAST, T5 x 2 LAMPS
F1	FU004UK	FUSE HOLDER
	FU019UK	FUSE, 2 A
FN1	FN0045 (HSS3)	FAN, 306 mm, 230V
	FN0042 (HSS4)	FAN, 368 mm, 230V
H1	C0761 (HSS3)	ELEMENT, 230V, 1500W
	C0159 (HSS4)	ELEMENT, 230V, 1850W
H2	C0763 (HSS3)	ELEMENT, 208V, 450W
	C0762 (HSS3)	ELEMENT, 230V, 450W
	C0157 (HSS4)	ELEMENT, 208V, 300W (2 per SHELF)
	C0158 (HSS4)	ELEMENT, 230V, 300W (2 per SHELF)
L1	LI010UK	PILOT LIGHT, CLEAR, 250 V
L2	FL0044 (HSS3)	21W LAMP (COATED)
	FL0045 (HSS4)	28W LAMP (COATED)
R1	R0180	RELAY, SPST, N.O., 240V
R2	R0180	RELAY, SPST, N.O., 240V
SW1	SW040UK	SWITCH, ROCKER
SW2	SW040UK	SWITCH, ROCKER
T1	T0107	THERMOSTAT, BI-METAL
T2	T0106	THERMOSTAT, 30-120°C, NO
	K0049	KNOB, THERMOSTAT
TB1	TB0004	3 x 8AWG TERM. EARTH SEC.
	TB0005	3 x 8AWG TERM. END PLATE
	TB0100	3 x 10 AWG TERM. SECTION
	TB0102	3 x 10 AWG TERM. END PLATE
	TB0106	JUMPER, 2 POLE x 10 AWG
	TB0109	END STOP
TB2	TB0059	TERMINAL BLOCK, 2 POLE
TB3 &	TB0064	4 cond. TERM. SECTION
TB4	TB0068	END PLATE

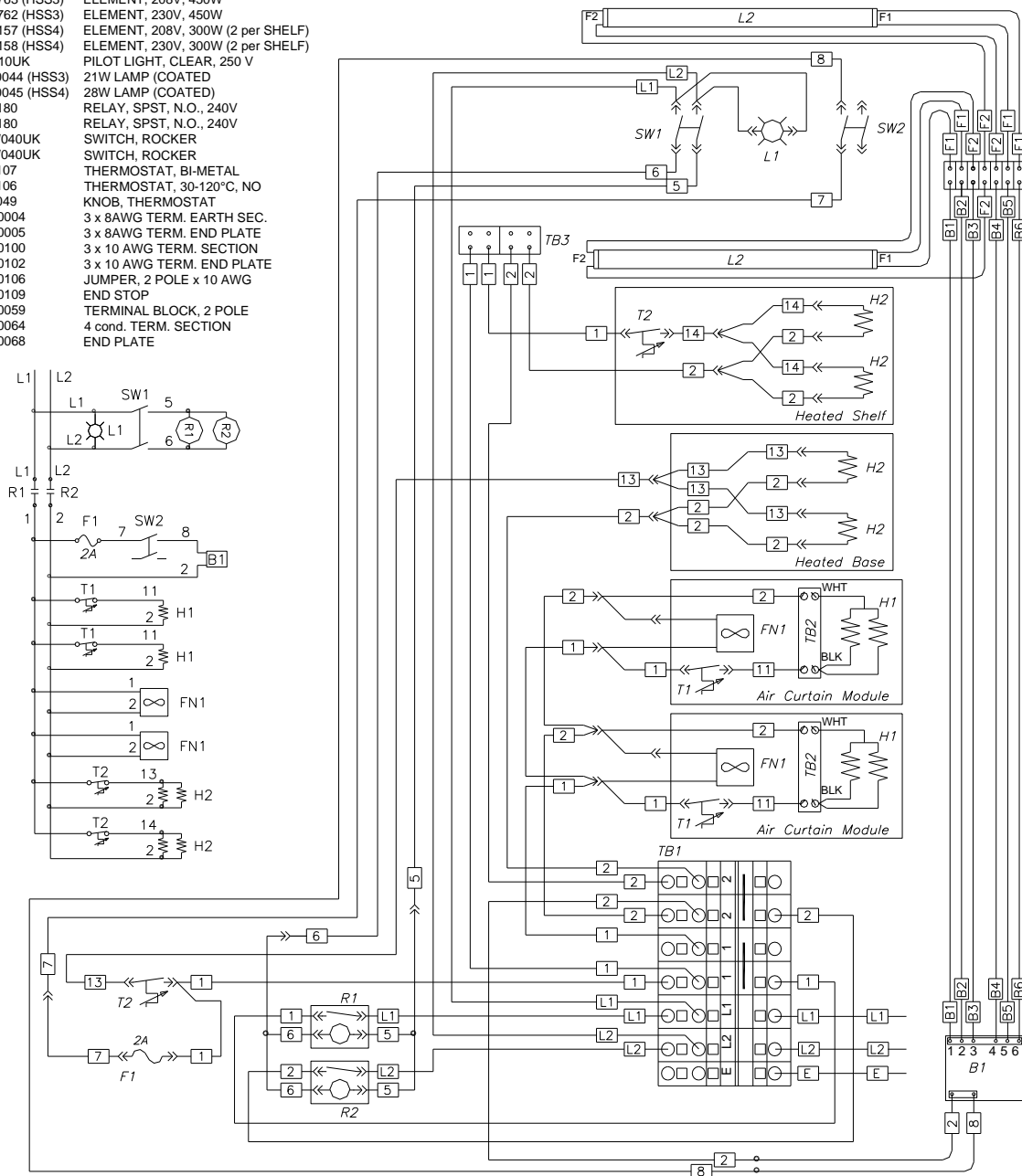

**HSS3-2**

VOLTAGE	AMPS	KILOWATTS	BREAKER
208	16.6	3.45	30
220	16.7	3.68	30
230	17.5	4.02	30
240	18.2	4.38	30

WIRING DIAGRAM: SB70092400

**HSS4-2**

VOLTAGE	AMPS	KILOWATTS	BREAKER
208	20.8	4.33	30
220	20.9	4.60	30
230	21.8	5.02	30
240	22.8	5.47	30

WIRING DIAGRAM: SB70091200

**HSS3-2 & HSS4-2 (UL)**

**COMPONENT LEGEND**

KEY	Part No.	DESCRIPTION
B1	B0090	BALLAST, T5 x 2 LAMPS
F1	FU004UK	FUSE HOLDER
	FU019UK	FUSE, 2 A
FN1	FN0045 (HSS3)	FAN, 306 mm, 230V
	FN0044 (HSS4)	FAN, 368 mm, 230V
H1	C0761 (HSS3)	ELEMENT, 230V, 1500W
	C0159 (HSS4)	ELEMENT, 230V, 1850W
H2	C0763 (HSS3)	ELEMENT, 208V, 450W
	C0762 (HSS3)	ELEMENT, 230V, 450W
	C0157 (HSS4)	ELEMENT, 208V, 300W (2 per SHELF)
	C0158 (HSS4)	ELEMENT, 230V, 300W (2 per SHELF)
L1	LI010UK	PILOT LIGHT, CLEAR, 250 V
L2	FL0044 (HSS3)	21W LAMP (COATED)
	FL0045 (HSS4)	28W LAMP (COATED)
R1	R0180	RELAY, SPST, N.O., 240V
R2	R0180	RELAY, SPST, N.O., 240V
SW1	SW040UK	SWITCH, ROCKER
SW2	SW040UK	SWITCH, ROCKER
T1	T0107	THERMOSTAT, BI-METAL
T2	T0106	THERMOSTAT, 30-120°C, NO KNOB, THERMOSTAT
TB1	TB0004	3 x 8AWG TERM. EARTH SEC.
	TB0005	3 x 8AWG TERM. END PLATE
	TB0100	3 x 10 AWG TERM. SECTION
	TB0102	3 x 10 AWG TERM. END PLATE
	TB0106	JUMPER, 2 POLE x 10 AWG
	TB0109	END STOP
TB2	TB0059	TERMINAL BLOCK, 2 POLE
TB3 & TB0064		4 cond. TERM. SECTION
TB4	TB0068	END PLATE

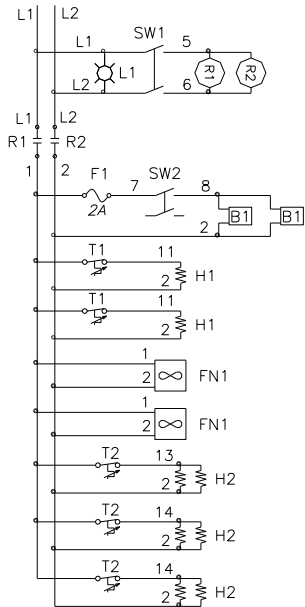

**HSS3-3**

VOLTAGE	AMPS	KILOWATTS	BREAKER
208	18.8	3.90	30
220	18.6	4.10	30
230	19.4	4.47	40
240	20.3	4.88	30

WIRING DIAGRAM: SB70092500

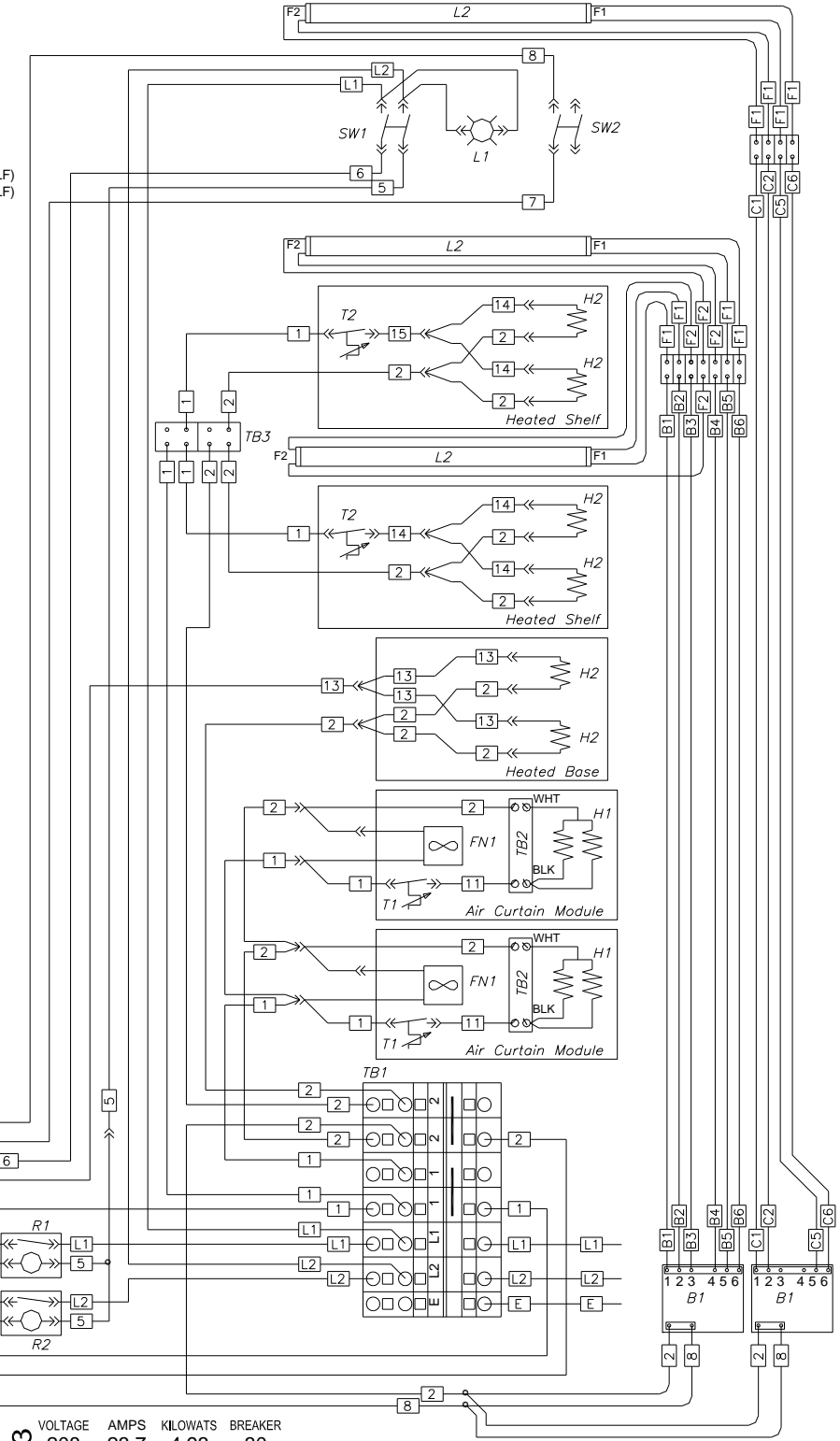

**HSS4-3**

VOLTAGE	AMPS	KILOWATTS	BREAKER
208	23.7	4.93	30
220	23.4	5.14	30
230	24.4	5.62	40
240	25.5	6.12	40

WIRING DIAGRAM: SB70091300

**HSS3-3 & HSS4-3 (UL)**

**COMPONENT LEGEND**

KEY	Part No.	DESCRIPTION
B1	B0090	BALLAST, T5 x 2 LAMPS
F1	FU004UK	FUSE HOLDER
	FU019UK	FUSE, 2 A
FN1	FN0045 (HSS3)	FAN, 306 mm, 230V
	FN0044 (HSS4)	FAN, 306 mm, 230V
H1	C0761 (HSS3)	ELEMENT, 230V, 1500W
	C0159 (HSS4)	ELEMENT, 230V, 1850W
H2	C0763 (HSS3)	ELEMENT, 208V, 450W
	C0762 (HSS3)	ELEMENT, 230V, 450W
	C0157 (HSS4)	ELEMENT, 208V, 300W (2 per SHELF)
	C0158 (HSS4)	ELEMENT, 230V, 300W (2 per SHELF)
L1	LI010UK	PILOT LIGHT, CLEAR, 250 V
L2	FL0044 (HSS3)	21W LAMP (COATED)
	FL0045 (HSS4)	28W LAMP (COATED)
R1	R0180	RELAY, SPST, N.O., 240V
R2	R0180	RELAY, SPST, N.O., 240V
SW1	SW040UK	SWITCH, ROCKER
SW2	SW040UK	SWITCH, ROCKER
T1	T0107	THERMOSTAT, BI-METAL
T2	T0106	THERMOSTAT, 30-120°C, NO
	K0049	KNOB, THERMOSTAT
TB1	TB0004	3 x 8AWG TERM. EARTH SEC.
	TB0005	3 x 8AWG TERM. END PLATE
	TB0100	3 x 10 AWG TERM. SECTION
	TB0102	3 x 10 AWG TERM. END PLATE
	TB0106	JUMPER, 2 POLE x 10 AWG
	TB0109	END STOP
TB2	TB0059	TERMINAL BLOCK, 2 POLE
TB3 & TB0064	TB0064	4 cond. TERM. SECTION
TB4	TB0068	END PLATE

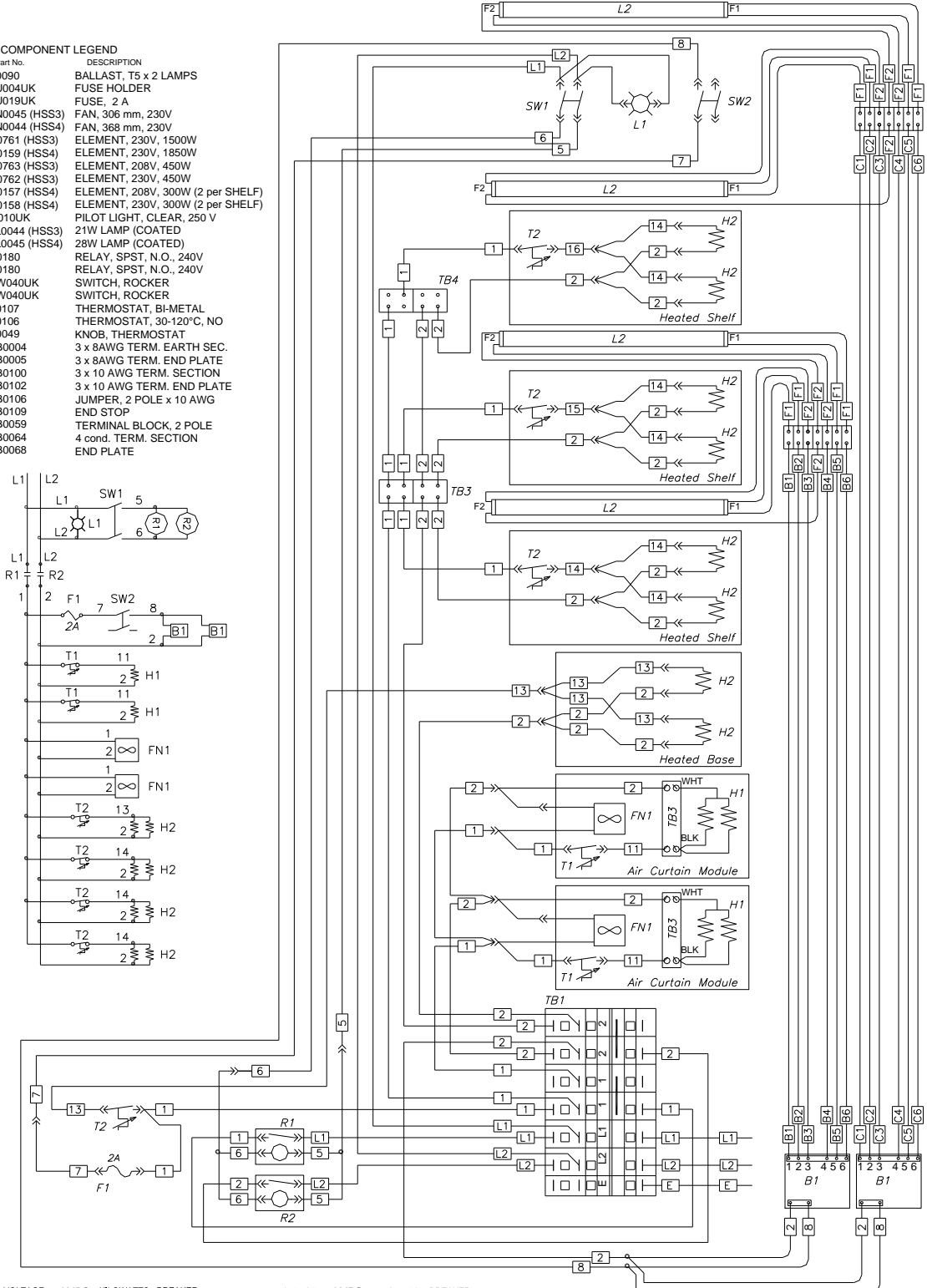

**HSS3-4**

VOLTAGE	AMPS	KILOWATTS	BREAKER
208	20.9	4.35	30
220	20.5	4.50	30
230	21.4	4.92	40
240	22.3	5.36	30

WIRING DIAGRAM: SB70092600

**HSS4-4**

VOLTAGE	AMPS	KILOWATTS	BREAKER
208	26.6	5.53	40
220	25.9	5.69	40
230	27.1	6.22	40
240	28.2	6.77	40

WIRING DIAGRAM: SB70091400

**HSS3-4 & HSS4-4 (UL)**



**COMPONENT LEGEND**

KEY	Part No.	DESCRIPTION
B1	B0090	BALLAST, T5 x 2 LAMPS
F1	FU004UK	FUSE HOLDER
	FU019UK	FUSE, 2 A
FN1	FN0045 (HSS3)	FAN, 306 mm, 230V
	FN0044 (HSS4)	FAN, 368 mm, 230V
H1	C0761 (HSS3)	ELEMENT, 230V, 1500W
	C0159 (HSS4)	ELEMENT, 230V, 1850W
H2	C0763 (HSS3)	ELEMENT, 208V, 450W
	C0762 (HSS3)	ELEMENT, 230V, 450W
	C0157 (HSS4)	ELEMENT, 208V, 300W (2 per SHELF)
	C0158 (HSS4)	ELEMENT, 230V, 300W (2 per SHELF)
L1	LI010UK	PILOT LIGHT, CLEAR, 250 V
L2	FL0044 (HSS3)	21W LAMP (COATED)
	FL0045 (HSS4)	28W LAMP (COATED)
R1	R0180	RELAY, SPST, N.O., 240V
R2	R0180	RELAY, SPST, N.O., 240V
SW1	SW040UK	SWITCH, ROCKER
SW2	SW040UK	SWITCH, ROCKER
T1	T0107	THERMOSTAT, BI-METAL
T2	T0106	THERMOSTAT, 30-120°C, NO
	K0049	KNOB, THERMOSTAT
TB1	TB0004	3 x 8AWG TERM. EARTH SEC.
	TB0005	3 x 8AWG TERM. END PLATE
	TB0100	3 x 10 AWG TERM. SECTION
	TB0102	3 x 10 AWG TERM. END PLATE
	TB0106	JUMPER, 2 POLE x 10 AWG
	TB0109	END STOP
TB2	TB0059	TERMINAL BLOCK, 2 POLE
TB3 & TB0064		4 cond. TERM. SECTION
TB4	TB0068	END PLATE

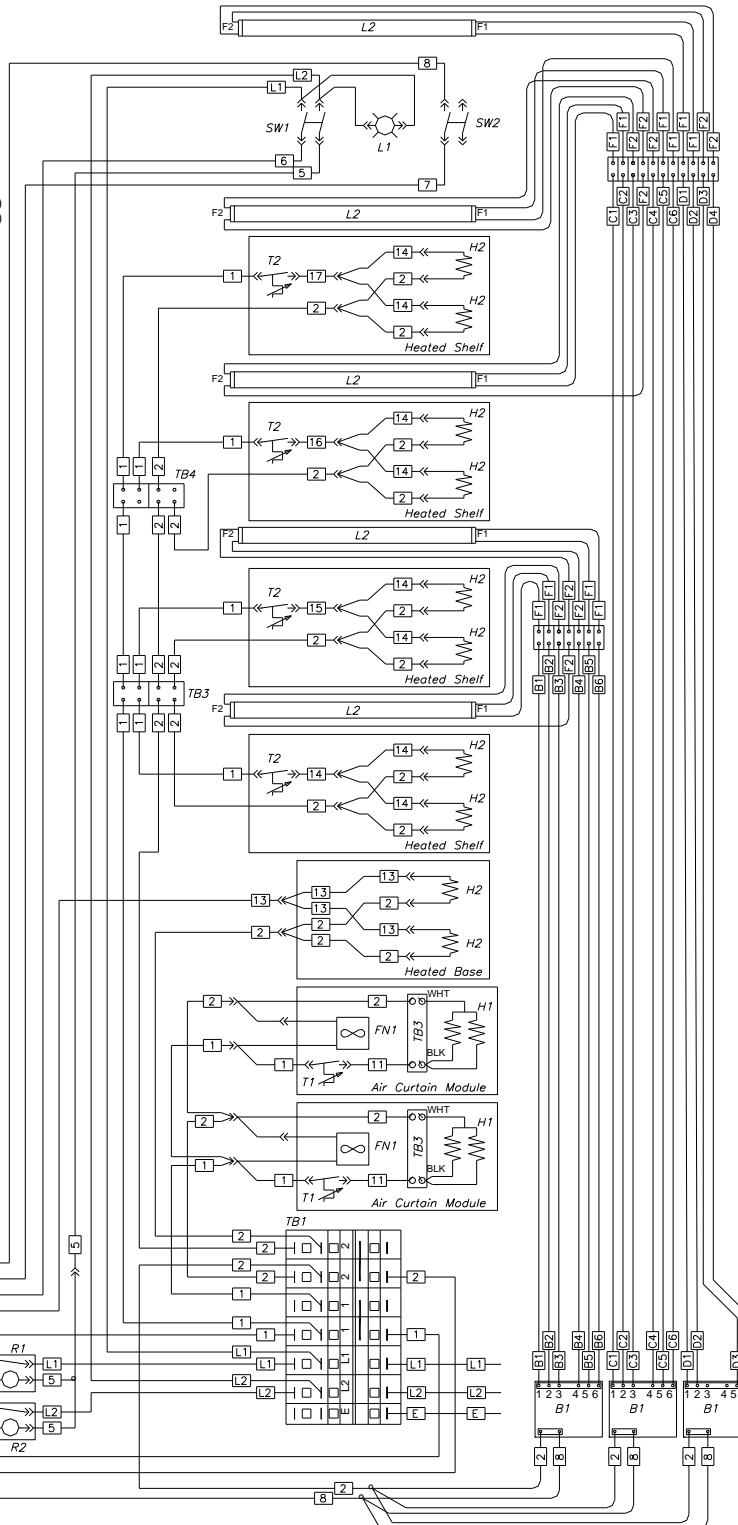
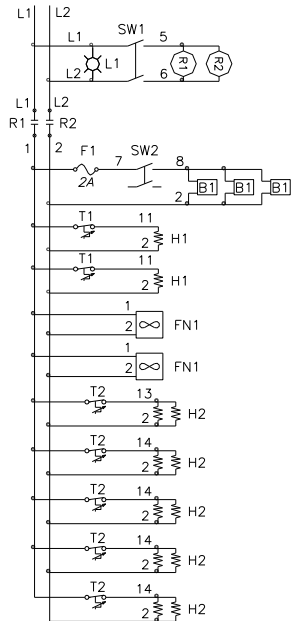

**HSS3-5**

VOLTAGE	AMPS	KILOWATTS	BREAKER
208	23.1	4.80	30
220	22.3	4.91	30
230	24.4	5.85	40
240	23.3	5.37	30

WIRING DIAGRAM: SB70093000

**HSS4-5**

VOLTAGE	AMPS	KILOWATTS	BREAKER
208	29.5	6.13	40
220	28.4	6.24	40
230	29.7	6.82	40
240	31.0	7.43	40

WIRING DIAGRAM: SB70093100

**HSS3-5 & HSS4-5 (UL)**

**COMPONENT LEGEND**

KEY	Part No.	DESCRIPTION
B1	B0090	BALLAST, T5 x 2 LAMPS
F1	FU004UK	FUSE HOLDER
	FU019UK	FUSE, 2 A
FN1	FN0042	FAN, 368 mm, 230V
H1	C0159	ELEMENT, 230V, 1850W
H2	C0157	ELEMENT, 208V, 300W
	C0158	ELEMENT, 230V, 300W
L1	LI010UK	PILOT LIGHT, CLEAR, 250 V
L2	FL0047	14W LAMP (COATED)
R1	R0180	RELAY, SPST, N.O., 240V
R2	R0180	RELAY, SPST, N.O., 240V
SW1	SW040UK	SWITCH, ROCKER
SW2	SW040UK	SWITCH, ROCKER
T1	T0107	THERMOSTAT, BI-METAL
T2	T0106	THERMOSTAT, 30-120°C, NO
	K0049	KNOB, THERMOSTAT
TB1	TB0004	3 x 8AWG TERM. EARTH SEC.
	TB0005	3 x 8AWG TERM. END PLATE
	TB0100	3 x 10 AWG TERM. SECTION
	TB0102	3 x 10 AWG TERM. END PLATE
	TB0106	JUMPER, 2 POLE x 10 AWG
	TB0109	END STOP
TB2	TB0059	TERMINAL BLOCK, 2 POLE
TB3	TB0064	4 cond. TERM. SECTION
	TB0068	END PLATE

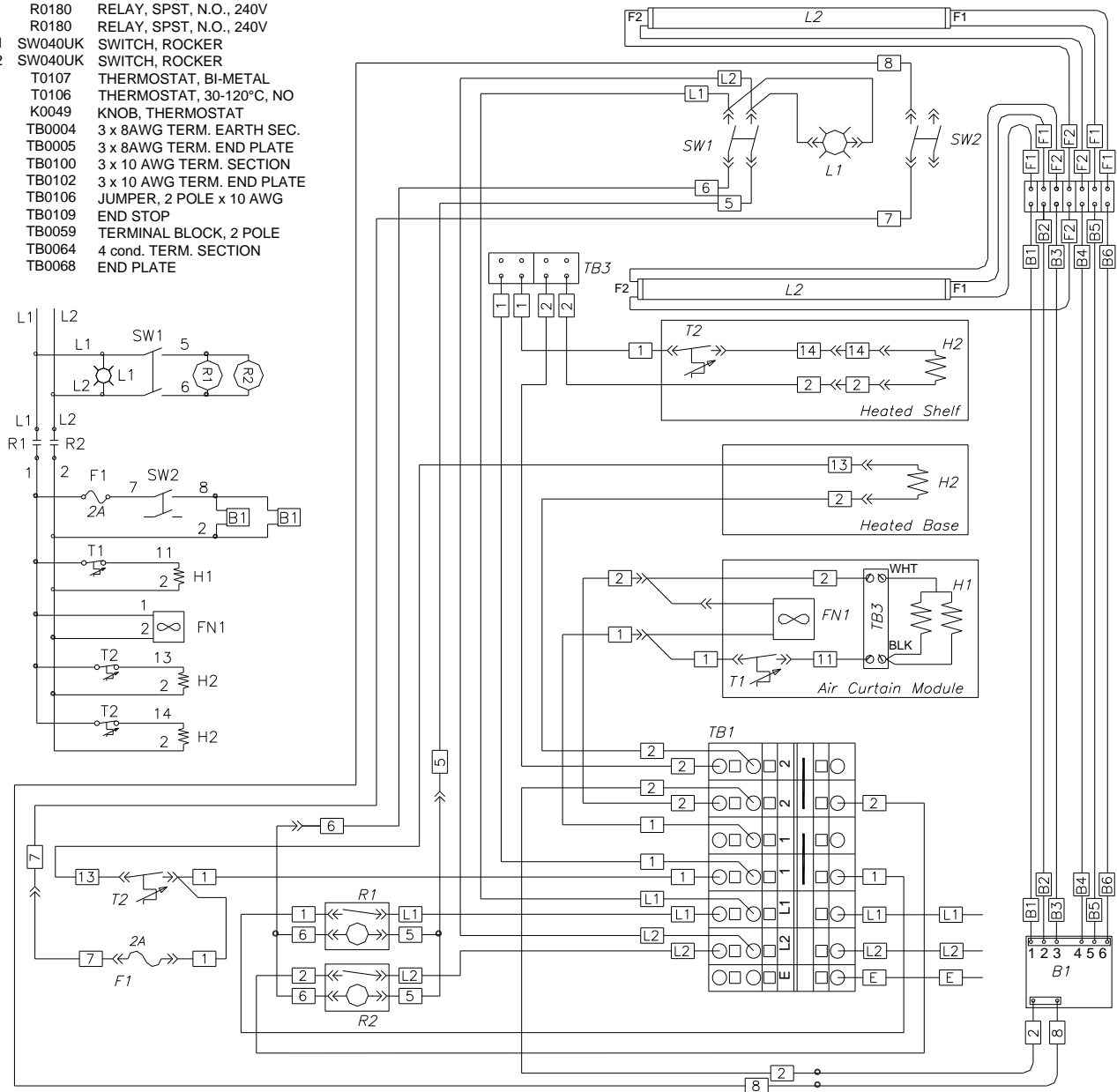

**HSS2-2**

VOLTAGE	AMPS	KILOWATTS	BREAKER
208	10.5	2.18	15
220	10.5	2.32	15
230	11.0	2.54	15
240	11.5	2.76	15

WIRING DIAGRAM: SB70091500

**HSS2-2 (UL)**

**COMPONENT LEGEND**

KEY	Part No.	DESCRIPTION
B1	B0090	BALLAST, T5 x 2 LAMPS
F1	FU004UK	FUSE HOLDER
	FU019UK	FUSE, 2 A
FN1	FN0044	FAN, 368 mm, 230V
H1	C0159	ELEMENT, 230V, 1850W
H2	C0157	ELEMENT, 208V, 300W
	C0158	ELEMENT, 230V, 300W
L1	LI010UK	PILOT LIGHT, CLEAR, 250 V
L2	FL0047	14W LAMP (COATED)
R1	R0180	RELAY, SPST, N.O., 240V
R2	R0180	RELAY, SPST, N.O., 240V
SW1	SW040UK	SWITCH, ROCKER
SW2	SW040UK	SWITCH, ROCKER
T1	T0107	THERMOSTAT, BI-METAL
T2	T0106	THERMOSTAT, 30-120°C, NO K0049
	K0049	KNOB, THERMOSTAT
TB1	TB0004	3 x 8AWG TERM. EARTH SEC.
	TB0005	3 x 8AWG TERM. END PLATE
	TB0100	3 x 10 AWG TERM. SECTION
	TB0102	3 x 10 AWG TERM. END PLATE
	TB0106	JUMPER, 2 POLE x 10 AWG
	TB0109	END STOP
TB2	TB0059	TERMINAL BLOCK, 2 POLE
TB3	TB0064	4 cond. TERM. SECTION
	TB0068	END PLATE

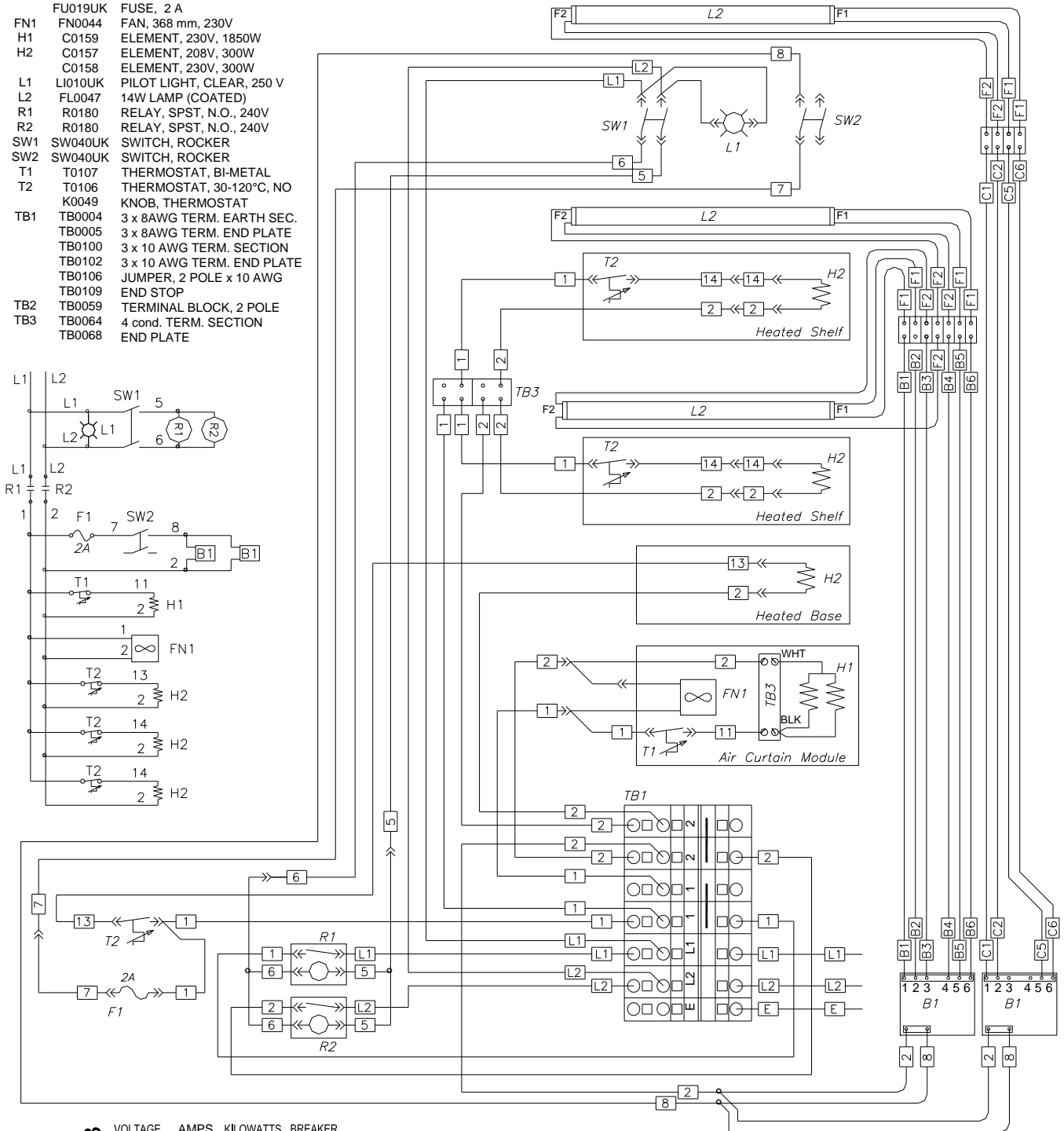

**HSS2-3**

VOLTAGE	AMPS	KILOWATTS	BREAKER
208	11.9	2.48	15
220	11.8	2.59	15
230	12.3	2.84	20
240	12.9	3.09	20

WIRING DIAGRAM: SB70091600

**HSS2-3 (UL)**

**COMPONENT LEGEND**

KEY	Part No.	DESCRIPTION
B1	B0090	BALLAST, T5 x 2 LAMPS
F1	FU004UK	FUSE HOLDER
	FU019UK	FUSE, 2 A
FN1	FN0044	FAN, 368 mm, 230V
H1	C0159	ELEMENT, 230V, 1850W
H2	C0157	ELEMENT, 208V, 300W
	C0158	ELEMENT, 230V, 300W
L1	LI010UK	PILOT LIGHT, CLEAR, 250 V
L2	FL0047	14W LAMP (COATED)
R1	R0180	RELAY, SPST, N.O., 240V
R2	R0180	RELAY, SPST, N.O., 240V
SW1	SW040UK	SWITCH, ROCKER
SW2	SW040UK	SWITCH, ROCKER
T1	T0107	THERMOSTAT, BI-METAL
T2	T0106	THERMOSTAT, 30-120°C, NO
	K0049	KNOB, THERMOSTAT
TB1	TB0004	3 x 8AWG TERM. EARTH SEC.
	TB0005	3 x 8AWG TERM. END PLATE
	TB0100	3 x 10 AWG TERM. SECTION
	TB0102	3 x 10 AWG TERM. END PLATE
	TB0106	JUMPER, 2 POLE x 10 AWG
	TB0109	END STOP
TB2	TB0059	TERMINAL BLOCK, 2 POLE
TB3 &	TB0064	4 cond. TERM. SECTION
TB4	TB0068	END PLATE

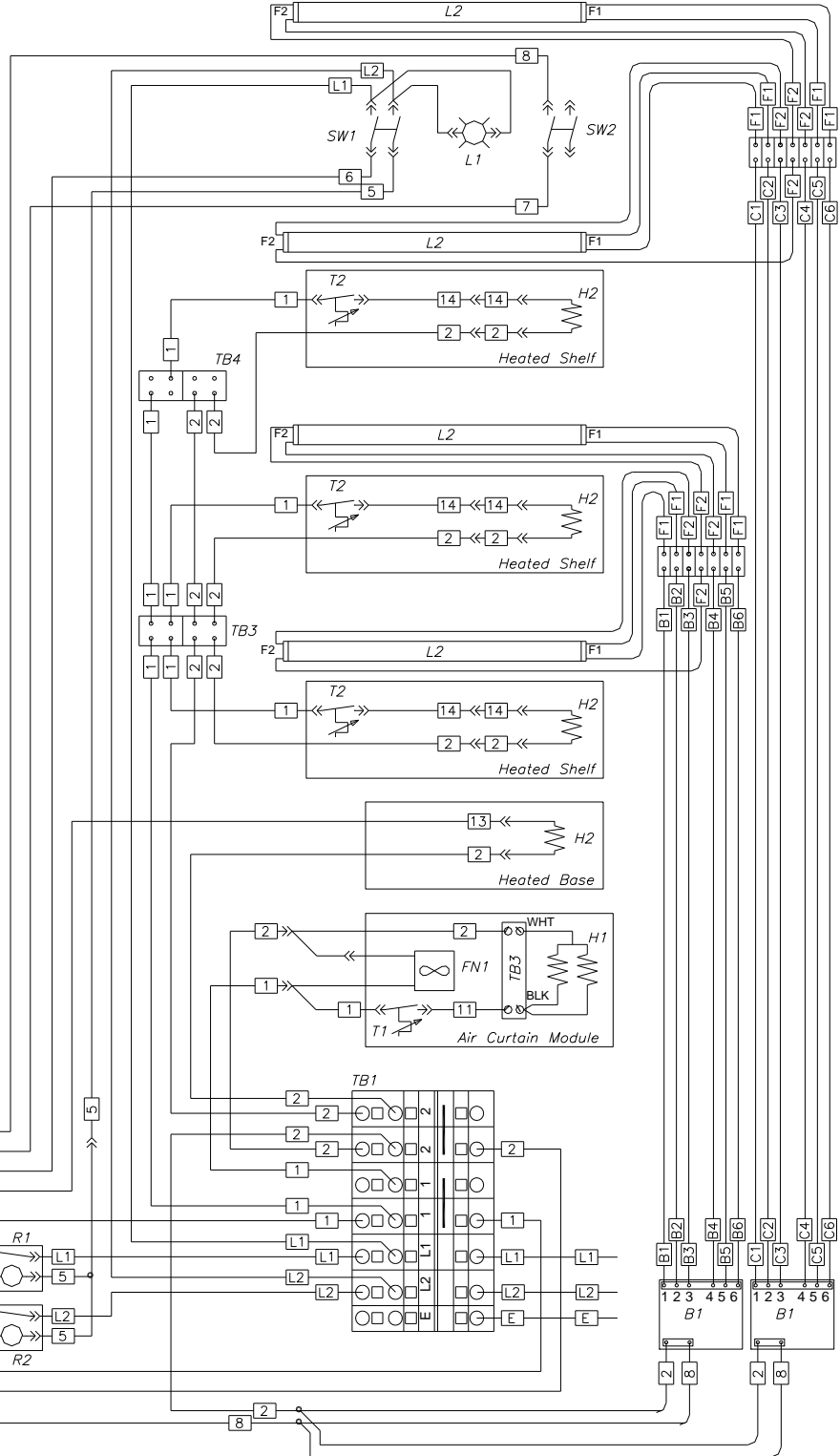
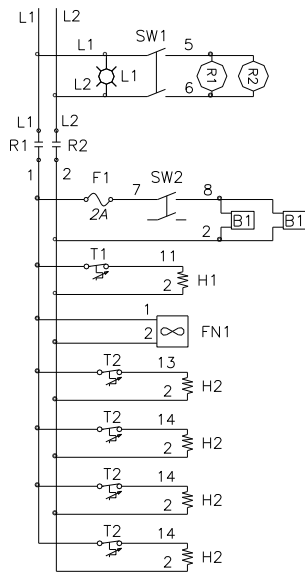

**HSS2-4**

VOLTAGE	AMPS	KILOWATTS	BREAKER
208	13.4	2.78	20
220	13.0	2.87	20
230	13.6	3.14	20
240	14.2	3.41	20

WIRING DIAGRAM: SB70091700

**HSS2-4 (UL)**

**COMPONENT LEGEND**

KEY	Part No.	DESCRIPTION
B1	B0090	BALLAST, T5 x 2 LAMPS
B2	B0094	FILTER, RFI
F1	FU004UK	FUSE HOLDER
	FU019UK	FUSE, 2 A
FN1	FN0045	FAN, 306 mm, 230V
	FN0042	FAN, 368 mm, 230V
H1	C0761 (HSS3)	ELEMENT, 230V, 1500W
	C0159 (HSS4)	ELEMENT, 230V, 1850W
H2	C0762 (HSS3)	ELEMENT, 230V, 450W
	C0158 (HSS4)	ELEMENT, 230V, 300W (2 per SHELF)
L1	LI010UK	PILOT LIGHT, CLEAR, 250 V
L2	FL0044 (HSS3)	21W LAMP (COATED)
	FL0045 (HSS4)	28W LAMP (COATED)
R1	R0180	RELAY, SPST, N.O., 240V
R2	R0180	RELAY, SPST, N.O., 240V
SW1	SW040UK	SWITCH, ROCKER
SW2	SW040UK	SWITCH, ROCKER
T1	T0107	THERMOSTAT, BI-METAL
T2	T0106	THERMOSTAT, 30-120°C, NO
	K0049	KNOB, THERMOSTAT
TB1	TB0004	3 x 8AWG TERM. EARTH SEC.
	TB0005	3 x 8AWG TERM. END PLATE
	TB0100	3 x 10 AWG TERM. SECTION
	TB0102	3 x 10 AWG TERM. END PLATE
	TB0106	JUMPER, 2 POLE x 10 AWG
	TB0109	END STOP
TB2	TB0059	TERMINAL BLOCK, 2 POLE
TB3 & TB4	TB0064	4 cond. TERM. SECTION
TB4	TB0068	END PLATE

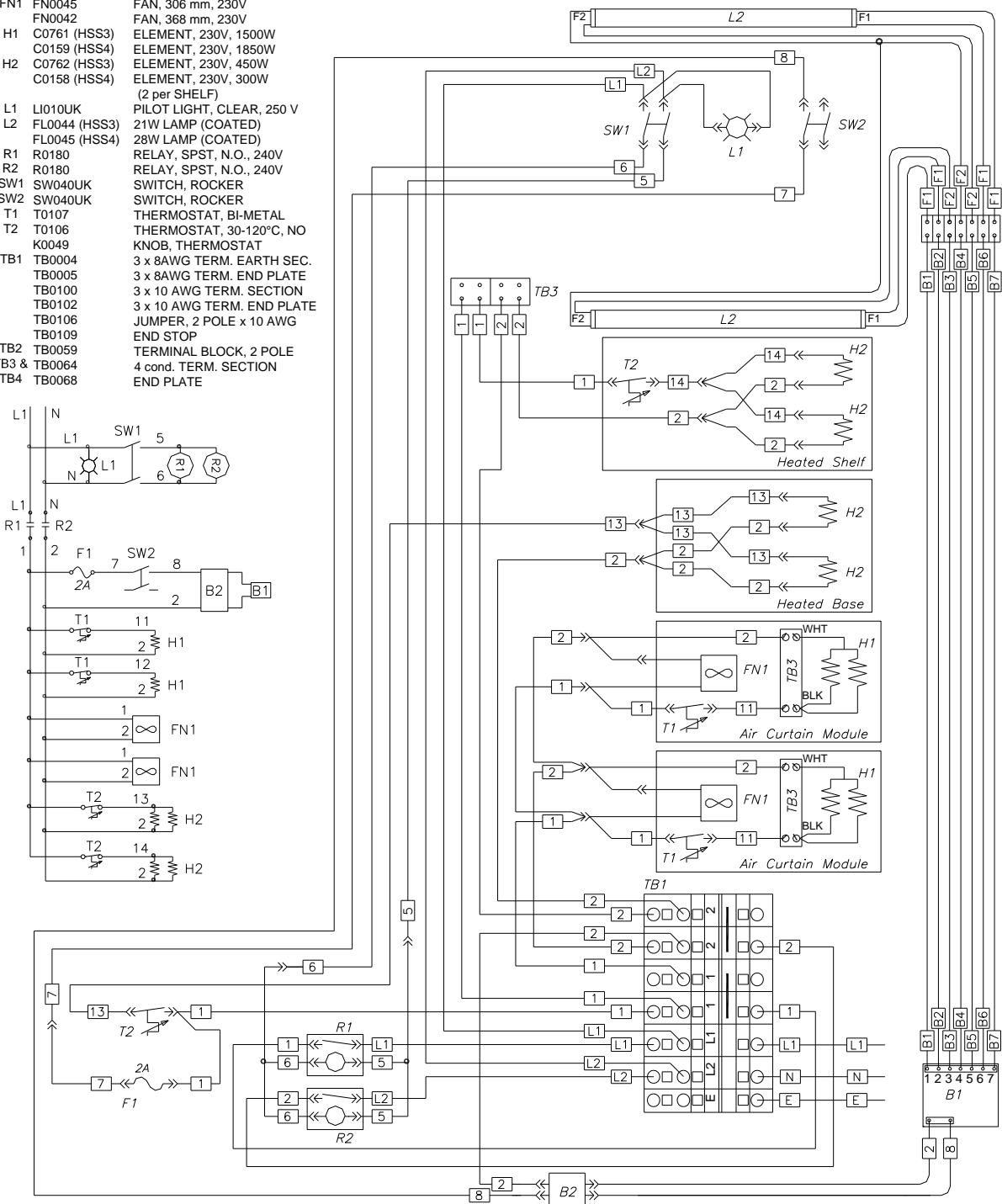

HSS3-2	VOLTAGE	AMPS	KILOWATTS	BREAKER
	220	16.7	3.68	32
	230	17.5	4.02	32

WIRING DIAGRAM: SB70092700

HSS4-2	VOLTAGE	AMPS	KILOWATTS	BREAKER
	220	20.9	4.60	32
	230	21.8	5.02	32

WIRING DIAGRAM: SB70091800

**HSS3-2 & HSS4-2 (CE)**

**COMPONENT LEGEND**

KEY	Part No.	DESCRIPTION
B1	B0090	BALLAST, T5 x 2 LAMPS
B2	B0094	FILTER, RFI
F1	FU004UK	FUSE HOLDER
	FU019UK	FUSE, 2 A
FN1	FN0045	FAN, 306 mm, 230V
	FN0044	FAN, 368 mm, 230V
H1	C0761 (HSS3)	ELEMENT, 230V, 1500W
	C0159 (HSS4)	ELEMENT, 230V, 1850W
H2	C0762 (HSS3)	ELEMENT, 230V, 450W
	C0158 (HSS4)	ELEMENT, 230V, 300W (2 per SHELF)
L1	LI010UK	PILOT LIGHT, CLEAR, 250 V
L2	FL0044 (HSS3)	21W LAMP (COATED)
	FL0045 (HSS4)	28W LAMP (COATED)
R1	R0180	RELAY, SPST, N.O., 240V
R2	R0180	RELAY, SPST, N.O., 240V
SW1	SW040UK	SWITCH, ROCKER
SW2	SW040UK	SWITCH, ROCKER
T1	T0107	THERMOSTAT, BI-METAL
T2	T0106	THERMOSTAT, 30-120°C, NO KNOB, THERMOSTAT
TB1	TB0004	3 x 8AWG TERM. EARTH SEC.
	TB0005	3 x 8AWG TERM. END PLATE
	TB0100	3 x 10 AWG TERM. SECTION
	TB0102	3 x 10 AWG TERM. END PLATE
	TB0106	JUMPER, 2 POLE x 10 AWG
	TB0109	END STOP
TB2	TB0059	TERMINAL BLOCK, 2 POLE
TB3 & TB0064	TB0064	4 cond. TERM. SECTION
TB4	TB0068	END PLATE

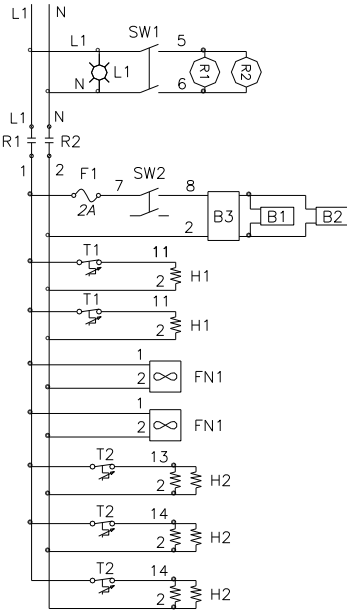

**HSS3-3** VOLTAGE 220 18.6 4.09 32  
 230 19.4 4.47 32  
**WIRING DIAGRAM: SB70092800**

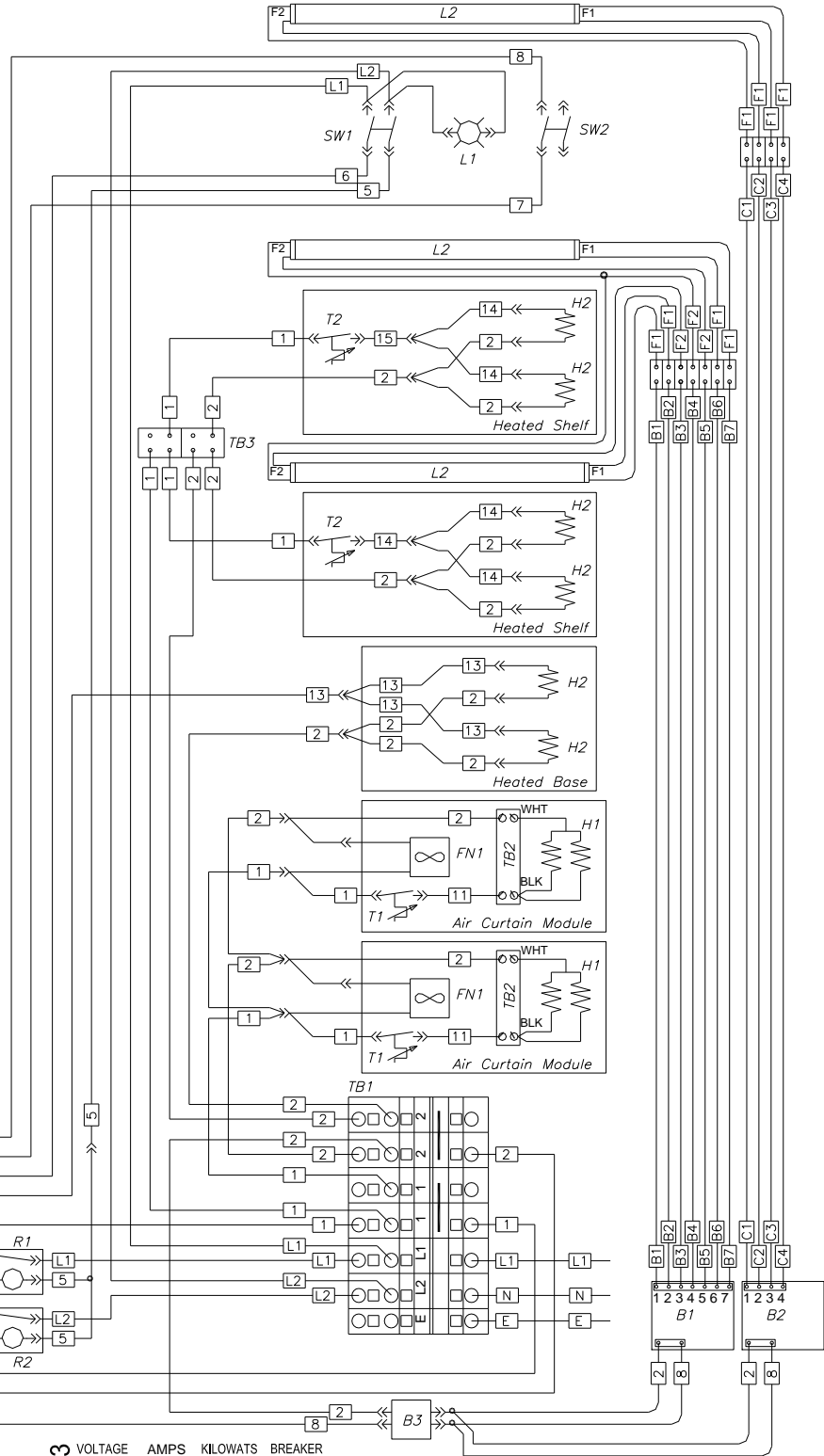

**HSS4-3** VOLTAGE 220 23.4 5.14 32  
 230 24.4 5.62 32  
**WIRING DIAGRAM: SB70091900**

**HSS3-3 & HSS4-3 (CE)**

**COMPONENT LEGEND**

KEY	Part No.	DESCRIPTION
B1	B0090	BALLAST, T5 x 2 LAMPS
B2	B0094	FILTER, RFI
F1	FU004UK	FUSE HOLDER
	FU019UK	FUSE, 2 A
FN1	FN0045	FAN, 306 mm, 230V
	FN0044	FAN, 368 mm, 230V
H1	C0761 (HSS3)	ELEMENT, 230V, 1500W
	C0159 (HSS4)	ELEMENT, 230V, 1850W
H2	C0762 (HSS3)	ELEMENT, 230V, 450W
	C0158 (HSS4)	ELEMENT, 230V, 300W
(2 per SHELF)		
L1	LI010UK	PILOT LIGHT, CLEAR, 250 V
L2	FL0044 (HSS3)	21W LAMP (COATED)
	FL0045 (HSS4)	28W LAMP (COATED)
R1	R0180	RELAY, SPST, N.O., 240V
R2	R0180	RELAY, SPST, N.O., 240V
SW1	SW040UK	SWITCH, ROCKER
SW2	SW040UK	SWITCH, ROCKER
T1	T0107	THERMOSTAT, BI-METAL
T2	T0106	THERMOSTAT, 30-120°C, NO
K0049	K0049	KNOB, THERMOSTAT
TB1	TB0004	3 x 8AWG TERM. EARTH SEC.
	TB0005	3 x 8AWG TERM. END PLATE
	TB0100	3 x 10 AWG TERM. SECTION
	TB0102	3 x 10 AWG TERM. END PLATE
	TB0106	JUMPER, 2 POLE x 10 AWG
	TB0109	END STOP
TB2	TB0059	TERMINAL BLOCK, 2 POLE
TB3 & TB0064	TB0064	4 cond. TERM. SECTION
TB4	TB0068	END PLATE

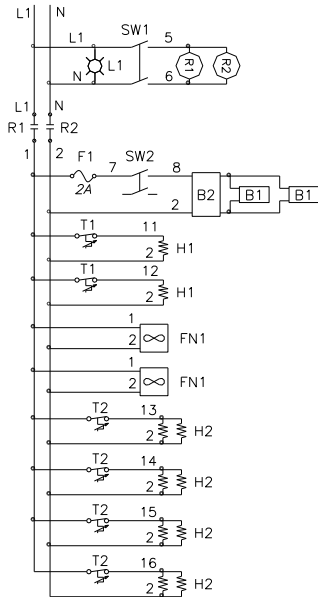

HSS3-4	VOLTAGE	AMPS	KILOWATTS	BREAKER
	220	20.5	4.50	32
	230	21.4	4.92	32

WIRING DIAGRAM: SB70092900

HSS4-4	VOLTAGE	AMPS	KILOWATTS	BREAKER
	220	25.9	5.69	32
	230	27.1	6.22	32

WIRING DIAGRAM: SB70092000

**HSS3-4 & HSS4-4 (CE)**

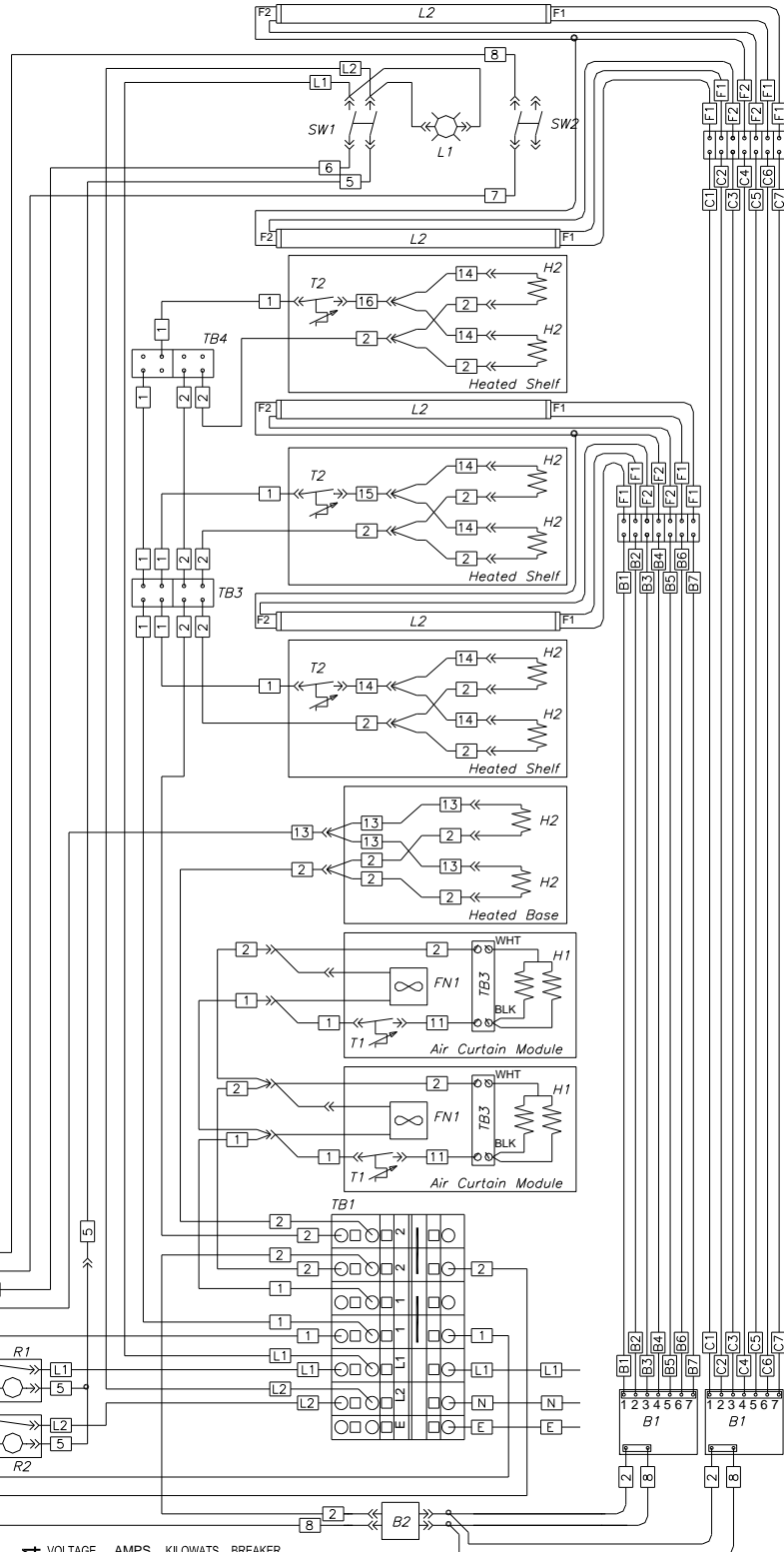

**COMPONENT LEGEND**

KEY	Part No.	DESCRIPTION
B1	B0090	BALLAST, T5 x 2 LAMPS
B2	B0094	FILTER, RFI
F1	FU004UK	FUSE HOLDER
	FU019UK	FUSE, 2 A
FN1	FN0045	FAN, 306 mm, 230V
	FN0044	FAN, 368 mm, 230V
H1	C0761 (HSS3)	ELEMENT, 230V, 1500W
	C0159 (HSS4)	ELEMENT, 230V, 1850W
H2	C0762 (HSS3)	ELEMENT, 230V, 450W
	C0158 (HSS4)	ELEMENT, 230V, 300W
		(2 per SHELF)
L1	LI010UK	PILOT LIGHT, CLEAR, 250 V
L2	FL0044 (HSS3)	21W LAMP (COATED)
	FL0045 (HSS4)	28W LAMP (COATED)
R1	R0180	RELAY, SPST, N.O., 240V
R2	R0180	RELAY, SPST, N.O., 240V
SW1	SW040UK	SWITCH, ROCKER
SW2	SW040UK	SWITCH, ROCKER
T1	T0107	THERMOSTAT, BI-METAL
T2	T0106	THERMOSTAT, 30-120°C, NO K0049
TB1	TB0004	3 x 8AWG TERM. EARTH SEC.
	TB0005	3 x 8AWG TERM. END PLATE
	TB0100	3 x 10 AWG TERM. SECTION
	TB0102	3 x 10 AWG TERM. END PLATE
	TB0106	JUMPER, 2 POLE x 10 AWG
	TB0109	END STOP
TB2	TB0059	TERMINAL BLOCK, 2 POLE
TB3 &	TB0064	4 cond. TERM. SECTION
TB4	TB0068	END PLATE

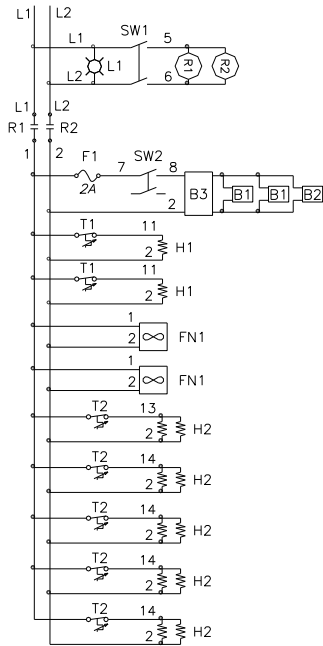

**HSS3-5**

VOLTAGE	AMPS	KILOWATTS	BREAKER
220	22.3	4.91	32
230	23.3	5.37	32

WIRING DIAGRAM: SB70093200

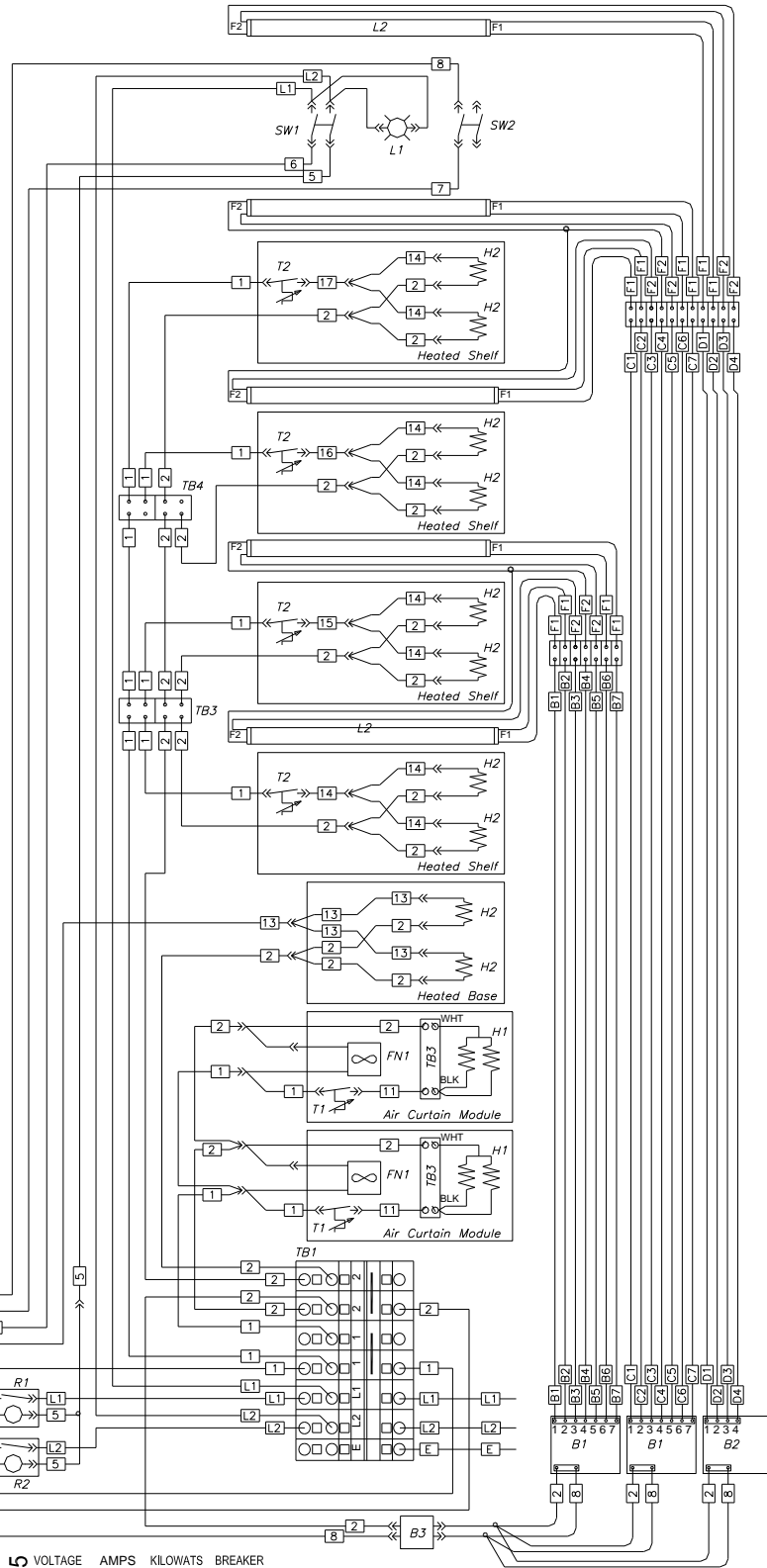

**HSS4-5**

VOLTAGE	AMPS	KILOWATTS	BREAKER
220	28.4	6.24	32
230	29.7	6.82	32

WIRING DIAGRAM: SB70093300

**HSS3-5 & HSS4-5 (CE)**



**COMPONENT LEGEND**

KEY	Part No.	DESCRIPTION
B1	B0091	BALLAST, T5 x 2 LAMPS
B2	B0094	FILTER, RFI
F1	FU004UK	FUSE HOLDER
	FU019UK	FUSE, 2 A
FN1	FN0042	FAN, 368 mm, 230V
H1	C0159	ELEMENT, 230V, 1850W
H2	C0158	ELEMENT, 230V, 300W
L1	LI010UK	PILOT LIGHT, CLEAR, 250 V
L2	FL0047	14 W LAMP (COATED)
R1	R0180	RELAY, SPST, N.O., 240V
R2	R0180	RELAY, SPST, N.O., 240V
SW1	SW040UK	SWITCH, ROCKER
SW2	SW040UK	SWITCH, ROCKER
T1	T0107	THERMOSTAT, BI-METAL
T2	T0106	THERMOSTAT, 30-120°C, NO KNOB, THERMOSTAT
KB0049		KNOB, THERMOSTAT
TB1	TB0004	3 x 8AWG TERM. EARTH SEC.
	TB0005	3 x 8AWG TERM. END PLATE
	TB0100	3 x 10 AWG TERM. SECTION
	TB0102	3 x 10 AWG TERM. END PLATE
	TB0106	JUMPER, 2 POLE x 10 AWG
	TB0109	END STOP
TB2	TB0059	TERMINAL BLOCK, 2 POLE
TB3	TB0064	4 cond. TERM. SECTION
	TB0068	END PLATE

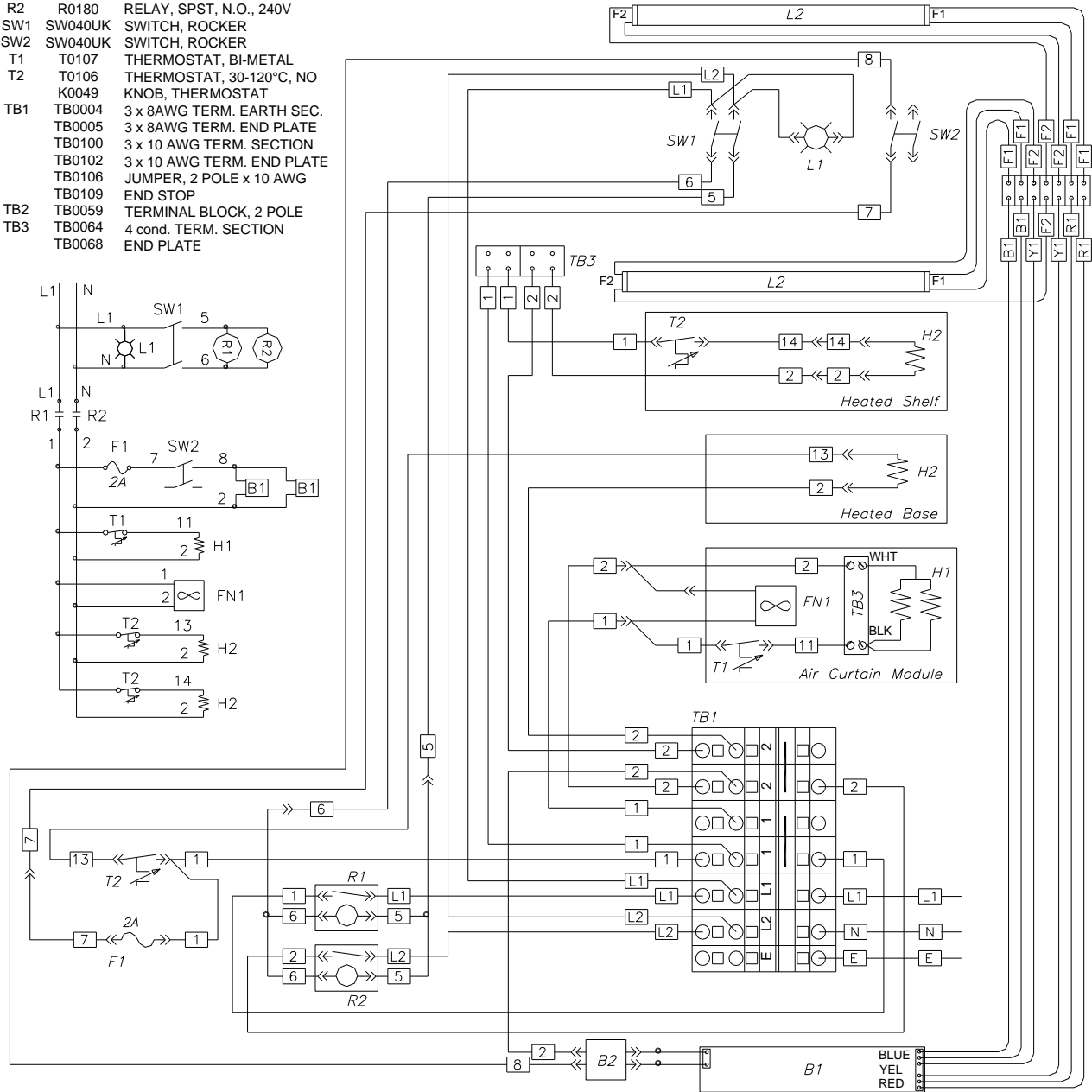

HSS2-2	VOLTAGE	AMPS	KILOWATTS	BREAKER
	220	10.5	2.32	16
	230	11.0	2.54	16

WIRING DIAGRAM: SB70092100

**HSS2-2 (CE)**

**COMPONENT LEGEND**

KEY	Part No.	DESCRIPTION
B1	B0091	BALLAST, T5 x 2 LAMPS
B2	B0093	BALLAST, T5 x 1 LAMP
B3	B0094	FILTER, RFI
F1	FU004UK	FUSE HOLDER
	FU019UK	FUSE, 2 A
FN1	FN0044	FAN, 368 mm, 230V
H1	C0159	ELEMENT, 230V, 1850W
H2	C0158	ELEMENT, 230V, 300W
L1	LI010UK	PILOT LIGHT, CLEAR, 250 V
L2	FL0047	14 W LAMP (COATED)
R1	R0180	RELAY, SPST, N.O., 240V
R2	R0180	RELAY, SPST, N.O., 240V
SW1	SW040UK	SWITCH, ROCKER
SW2	SW040UK	SWITCH, ROCKER
T1	T0107	THERMOSTAT, BI-METAL
T2	T0106	THERMOSTAT, 30-120°C, NO KNOB, THERMOSTAT
TB1	TB0004	3 x 8AWG TERM. EARTH SEC.
	TB0005	3 x 8AWG TERM. END PLATE
	TB0100	3 x 10 AWG TERM. SECTION
	TB0102	3 x 10 AWG TERM. END PLATE
	TB0106	JUMPER, 2 POLE x 10 AWG
	TB0109	END STOP
TB2	TB0059	TERMINAL BLOCK, 2 POLE
TB3	TB0064	4 cond. TERM. SECTION
	TB0068	END PLATE

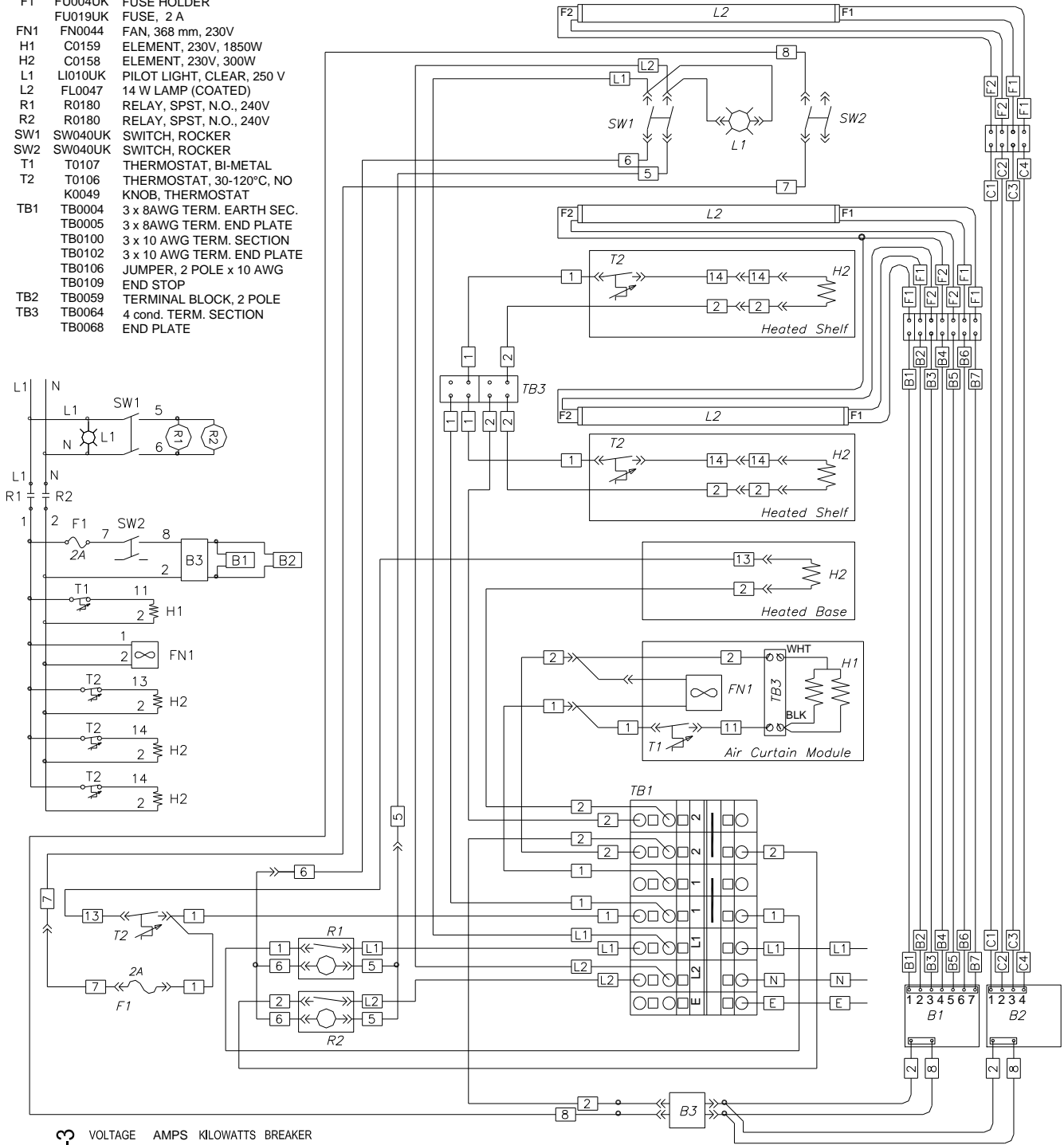

HSS2-3	VOLTAGE	AMPS	KILOWATTS	BREAKER
	220	11.8	2.60	16
	230	12.3	2.84	16

WIRING DIAGRAM: SB70092200

**HSS2-3 (CE)**

**COMPONENT LEGEND**

KEY	Part No.	DESCRIPTION
B1	B0091	BALLAST, T5 x 2 LAMPS
B2	B0094	FILTER, RFI
F1	FU004UK	FUSE HOLDER
	FU019UK	FUSE, 2 A
FN1	FN0044	FAN, 368 mm, 230V
H1	C0159	ELEMENT, 230V, 1850W
H2	C0158	ELEMENT, 230V, 300W
L1	LI010UK	PILOT LIGHT, CLEAR, 250 V
L2	FL0047	14 W LAMP (COATED)
R1	R0180	RELAY, SPST, N.O., 240V
R2	R0180	RELAY, SPST, N.O., 240V
SW1	SW040UK	SWITCH, ROCKER
SW2	SW040UK	SWITCH, ROCKER
T1	T0107	THERMOSTAT, BI-METAL
T2	T0106	THERMOSTAT, 30-120°C, NO
	K0049	KNOB, THERMOSTAT
TB1	TB0004	3 x 8AWG TERM. EARTH SEC.
	TB0005	3 x 8AWG TERM. END PLATE
	TB0100	3 x 10 AWG TERM. SECTION
	TB0102	3 x 10 AWG TERM. END PLATE
	TB0106	JUMPER, 2 POLE x 10 AWG
	TB0109	END STOP
TB2	TB0059	TERMINAL BLOCK, 2 POLE
TB3 &	TB0064	4 cond. TERM. SECTION
TB4	TB0068	END PLATE

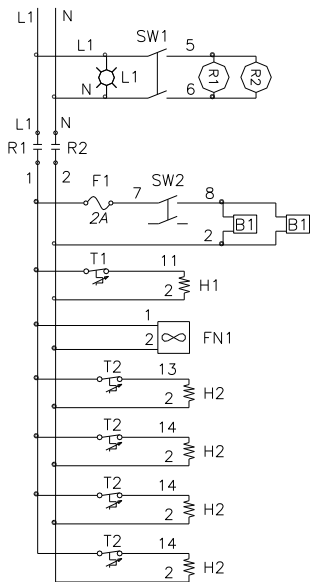

HSS2-4	VOLTAGE	AMPS	KILOWATTS	BREAKER
	220	13.0	2.87	16
	230	13.6	3.14	16

WIRING DIAGRAM: SB70092300

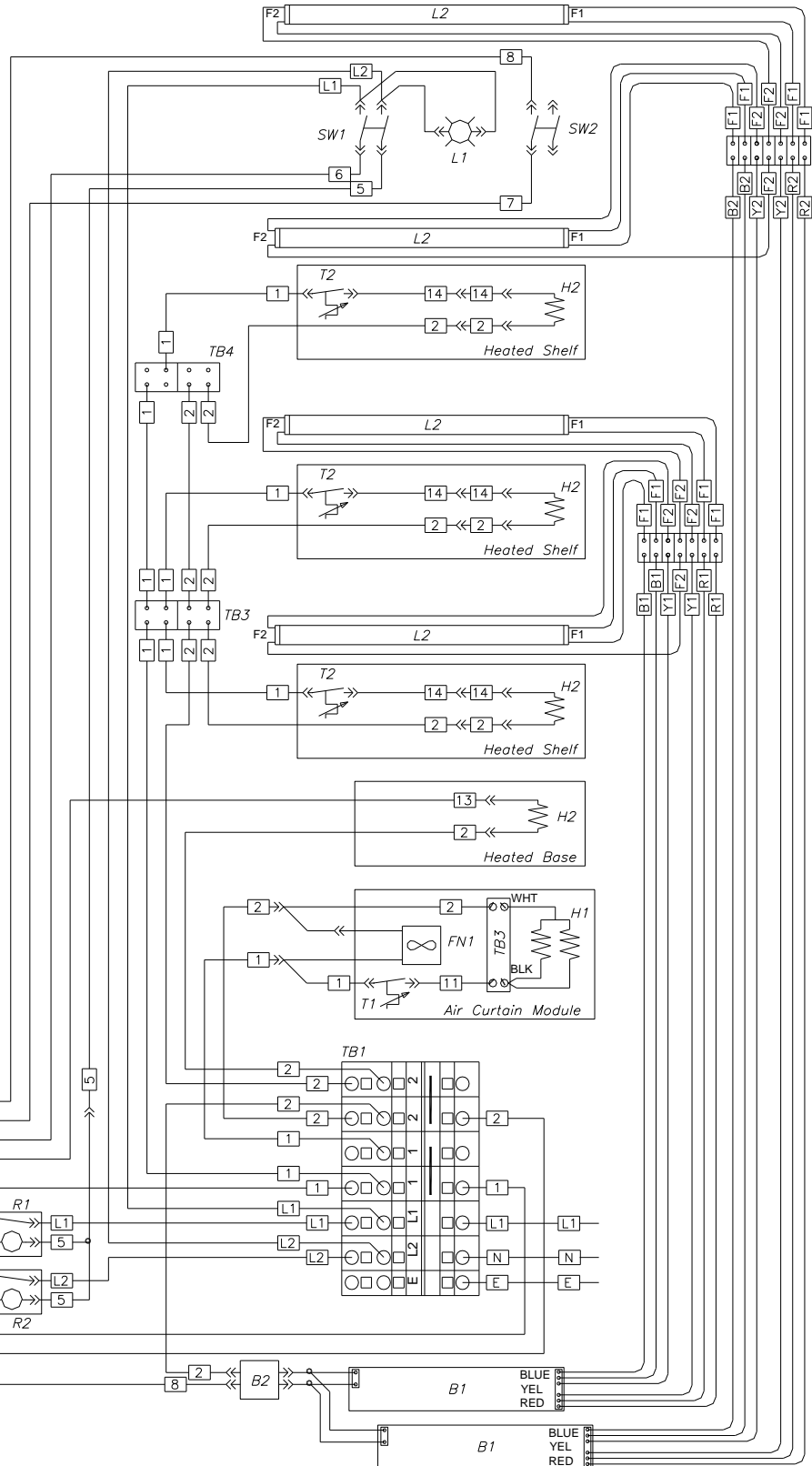

HSS2-4 (CE)

## Notes



2812 Grandview Drive, Simpsonville, S.C. 29680, USA  
<http://www.bkideas.com>

Made and printed in the U.S.A

CS-TM-003.01

Revised 10/01/18

---