



Mobile Hot Food Merchandiser Series

Series: MM

Operation Manual



BKI LIMITED WARRANTY

2812 Grandview Dr. • Simpsonville, SC 29680 • USA
(864) 963-3471 • Toll Free: (800) 927-6887 • Fax: (864) 963-5316

WHAT IS COVERED	<p>This warranty covers defects in material and workmanship under normal use, and applies only to the original purchaser providing that:</p> <ul style="list-style-type: none"><input type="checkbox"/> The equipment has not been accidentally or intentionally damaged, altered or misused;<input type="checkbox"/> The equipment is properly installed, adjusted, operated and maintained in accordance with national and local codes, and in accordance with the installation and operating instructions provided with this product.<input type="checkbox"/> The serial number rating plate affixed to the equipment has not been defaced or removed.
WHO IS COVERED	<p>This warranty is extended to the original purchaser and applies only to equipment purchased for use in the U.S.A.</p>
COVERAGE PERIOD	<ul style="list-style-type: none"><input type="checkbox"/> Warranty claims must be received in writing by BKI within one (1) year from date of installation or within one (1) year and three (3) months from date of shipment from the factory, whichever comes first.<input type="checkbox"/> COB Models: One (1) Year limited parts and labor.<input type="checkbox"/> COM Models: Two (2) Year limited parts and labor. COM convection ovens also have a two (2) year door warranty.<input type="checkbox"/> CO1 Models: Two (2) Year limited parts and labor. Five (5) Year limited door warranty.<input type="checkbox"/> Warranty period begins the date of dealer invoice to customer or ninety (90) days after shipment date from BKI, whichever comes first.
WARRANTY COVERAGE	<p>This warranty covers on-site labor, parts and reasonable travel time and travel expenses of the authorized service representative up to (100) miles round trip and (2) hours travel time and performed during regular, weekday business hours.</p>
EXCEPTIONS	<p>Any exceptions must be pre-approved in advance and in writing by BKI. The extended door warranty on convection ovens years 3 through 5 is a parts only warranty and does not include labor, travel, mileage or any other charges.</p>
EXCLUSIONS	<ul style="list-style-type: none"><input type="checkbox"/> Negligence or acts of God,<input type="checkbox"/> Thermostat calibrations after (30) days from equipment installation date,<input type="checkbox"/> Air and gas adjustments,<input type="checkbox"/> Light bulbs,<input type="checkbox"/> Glass doors and door adjustments,<input type="checkbox"/> Fuses,<input type="checkbox"/> Adjustments to burner flames and cleaning of pilot burners,<input type="checkbox"/> Tightening of screws or fasteners,<input type="checkbox"/> Failures caused by erratic voltages or gas suppliers,<input type="checkbox"/> Unauthorized repair by anyone other than a BKI Factory Authorized Service Center,<input type="checkbox"/> Damage in shipment,<input type="checkbox"/> Alteration, misuse or improper installation,<input type="checkbox"/> Thermostats and safety valves with broken capillary tubes,<input type="checkbox"/> Freight - other than normal UPS charges,<input type="checkbox"/> Ordinary wear and tear,<input type="checkbox"/> Failure to follow installation and/or operating instructions,<input type="checkbox"/> Events beyond control of the company.
INSTALLATION	<p>Leveling, as well as proper installation and check out of all new equipment - per appropriate installation and use materials – is the responsibility of the dealer or installer, not the manufacturer.</p>
REPLACEMENT PARTS	<p>BKI genuine Factory OEM parts receive a (90) day materials warranty effective from the date of installation by a BKI Factory Authorized Service Center.</p>

Table of Contents

Table of Contents	1
Introduction	2
Safety Precautions	2
Safety Signs and Messages	2
Safe Work Practices	3
Safety Labels	4
Health and Sanitation Practices	6
Food Handling	6
Storage of Raw Meats	6
Coding Cooked Foods	6
Storage of Prepared Foods	6
Operation	7
Controls and Indicators	7
Merchandiser Startup and Preheating	7
Temperature Adjustment	7
Operational Guidelines	7
Merchandiser Shutdown	8
Installation	9
Unpacking and Handling	9
Location and Placement	9
Electrical Information	9
Specifications	10
Maintenance	11
Scheduled Maintenance	11
Cleaning (Daily)	11
Troubleshooting	12
Accessories	13
Wiring Diagrams	14
Notes	16

BKI Worldwide is a wholly owned subsidiary of Standex International Corporation.

Introduction

Congratulations! You have chosen a **Mobile Merchandiser** that will give you many years of fine service from the original manufacturer, **BKI**.

The **BKI** name and trademark on this unit assures you of the finest in design and engineering — that it has been built with care and dedication — using the best materials available. Attention to the operating instructions regarding proper installation, operation, and maintenance will result in long lasting dependability to insure the highest profitable return on your investment.

NOTICE

PLEASE READ THIS ENTIRE MANUAL BEFORE OPERATING THE UNIT. If you have any questions, please contact your **BKI** Distributor. If they are unable to answer your questions, contact the **BKI** Technical Service Department, toll free: 1-800-927-6887. Outside the U.S., call 1-864-963-3471.

Safety Precautions

Always follow recommended safety precautions listed in this manual. Below is the safety alert symbol. When you see this symbol on your equipment, be alert to the potential for personal injury or property damage.



Safety Signs and Messages

The following Safety signs and messages are placed in this manual to provide instructions and identify specific areas where potential hazards exist and special precautions should be taken. Know and understand the meaning of these instructions, signs, and messages. Damage to the equipment, death or serious injury to you or other persons may result if these messages are not followed.

⚠ DANGER

This message indicates an imminently hazardous situation that, if not avoided, will result in death or serious injury.

⚠ WARNING

This message indicates a potentially hazardous situation, which, if not avoided, could result in death or serious injury.

⚠ CAUTION

This message indicates a potentially hazardous situation, which, if not avoided, may result in minor or moderate injury. It may also be used to alert against unsafe practices.

NOTICE

This message is used when special information, instructions or identification are required relating to procedures, equipment, tools, capacities and other special data.

Safe Work Practices

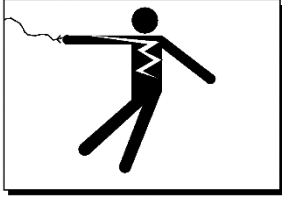

Beware of High Voltage

This equipment uses high voltage. Serious injury can occur if you or any untrained or unauthorized person installs, services, or repairs this equipment. Always Use an Authorized Service agent to Service Your Equipment.

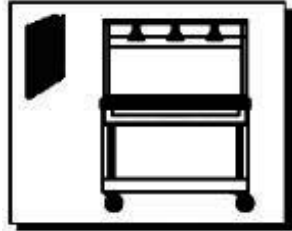

Keep this manual with the Equipment

This manual is an important part of your equipment. Always keep it near for easy access. If you need to replace this manual, contact:

BKI

Technical Services Department
 2812 Grandview Drive
 Simpsonville, S.C. 29680
 Or call toll free: 1-800-927-6887
 Outside the U.S., call 864-963-3471



Protect Children

Keep children away from this equipment. Children may not understand that this equipment is dangerous for them and others.

NEVER allow children to play near or operate your equipment.

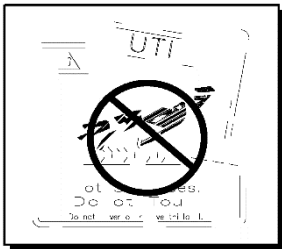

Keep Safety Labels Clean and in Good Condition

Do not remove or cover any safety labels on your equipment. Keep all safety labels clean and in good condition. Replace any damaged or missing safety labels. Refer to the Safety Labels section for illustration and location of safety labels on this unit. If you need a new safety label, obtain the number of the specific label illustrated on page 4, then contact:

BKI

Technical Services Department
 2812 Grandview Drive
 Simpsonville, S.C. 29680
 Or call toll free: 1-800-927-6887
 Outside the U.S., call 864-963-3471

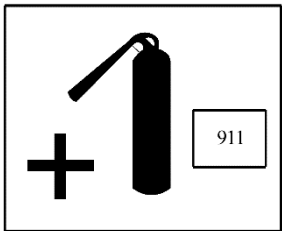

Be Prepared for Emergencies

Be prepared for fires, injuries, or other emergencies.

Keep a first aid kit and a fire extinguisher near the equipment. You must use a 40-pound Type BC fire extinguisher and keep it within 25 feet of your equipment.

Keep emergency numbers for doctors, ambulance services, hospitals, and the fire department near your telephone.

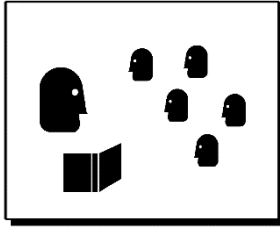
**Know your responsibilities as an Employer**

- Make certain your employees know how to operate the equipment.
- Make certain your employees are aware of the safety precautions on the equipment and in this manual.
- Make certain that you have thoroughly trained your employees about operating the equipment safely.
- Make certain the equipment is in proper working condition. If you make unauthorized modifications to the equipment, you will reduce the function and safety of the equipment.



California Residents Only. This product can expose you to chemicals including chromium, and lead which are known to the State of California to cause cancer and birth defects or other reproductive harm. For more information go to www.P65Warnings.ca.gov.

Safety Labels

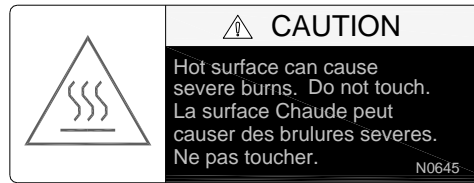

CAUTION
 Hot surface can cause severe burns. Do not touch.
 La surface Chaude peut causer des brulures severes. Ne pas toucher.
 N0645

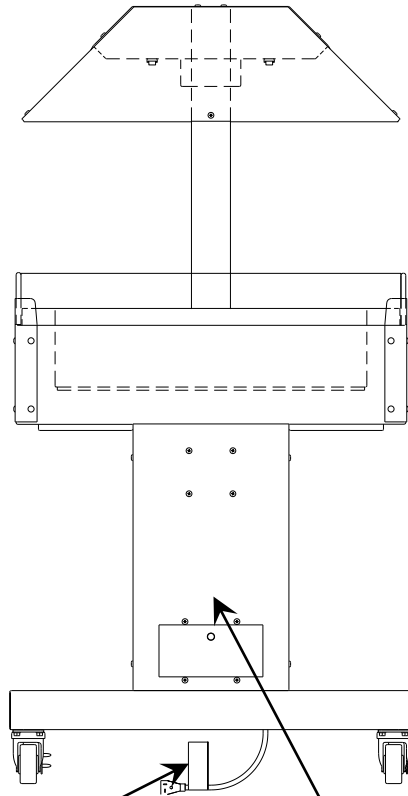
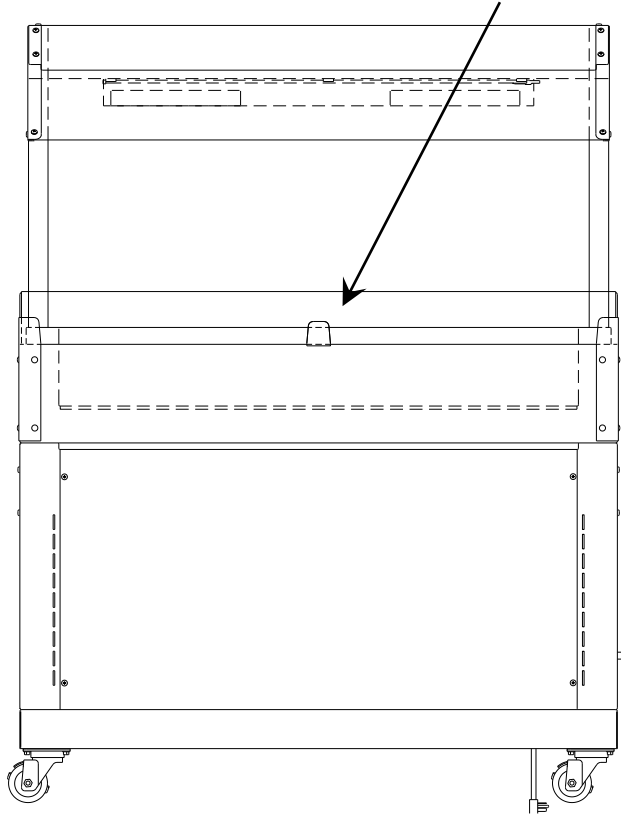

CAUTION
 Electrical Grounding Instructions - This appliance is equipped with a three-prong (grounding) plug for your protection against shock hazard and should be plugged directly into a properly grounded three-prong receptacle. Do not cut or remove the grounding prong from this plug.

AVERTIR
 Mise à la terre - Cet appareil est pourvu d'une fiche à trois broches dont une mise à la terre assurant une protection contre les chocs électriques. La prise dans laquelle elle est branchée doit être correctement mise à la terre. Ne pas couper ni enlever la broche de mise à la terre de la fiche.

DO NOT COVER or REMOVE THIS LABEL. NE RECOUVREZ PAS ou ENLEVEZ PAS CETTE ÉTIQUETTE

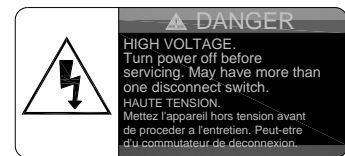

DANGER
 HIGH VOLTAGE. Turn power off before servicing. May have more than one disconnect switch.
 HAUTE TENSION. Mettez l'appareil hors tension avant de proceder a l'entretien. Peut-etre d'un commutateur de deconnexion.

Health and Sanitation Practices

BKI ovens are manufactured to comply with health regulations and are tested and certified to UL®, CUL®, and NSF® standards. You must operate the equipment properly using only quality products and use meat thermometers to insure meats are thoroughly cooked.

Food Handling

- Wash hands thoroughly in warm, soapy water after handling raw poultry or meats.
- Clean and sanitize all utensils and surfaces that have been in contact with raw products.
- **Never** place cooked meats on the same surfaces used to prepare raw meats, unless the area has been thoroughly cleaned and sanitized.

Storage of Raw Meats

- Designate an area or shelf strictly for the storage of all raw meats to be used in the oven.
- Raw product must always be stored at temperatures below 38° F. (3° C.).
- **Never** store or mix raw foods above cooked foods, as this is a health hazard. The drippings from raw foods contaminate cooked or processed foods.
- All chicken and chicken parts to be stored overnight must be thoroughly iced down and refrigerated.

Coding Cooked Foods

All products cooked during the day should be sold the same day.

NOTE: It is not the intent of the cooking program to have unsold merchandise at the end of the cooking day. Follow your company's procedures for the handling of any leftover product.

Storage of Prepared Foods

- Cold foods should be kept at or below 38° F. (3° C.).
- Hot foods must be maintained to meet local health codes, usually a minimum 145° F. (63° C.).

Operation

Controls and Indicators

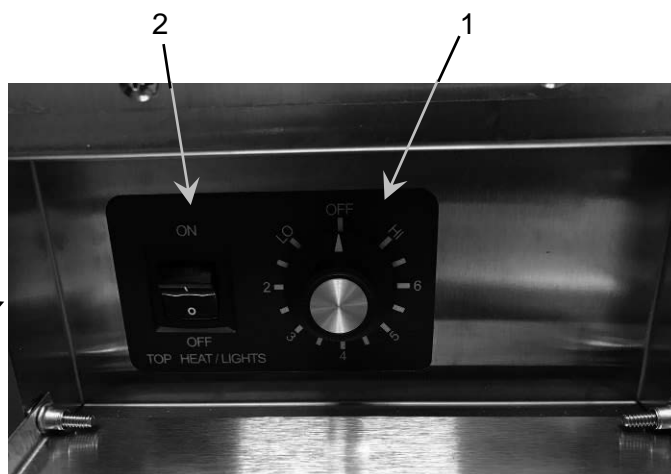
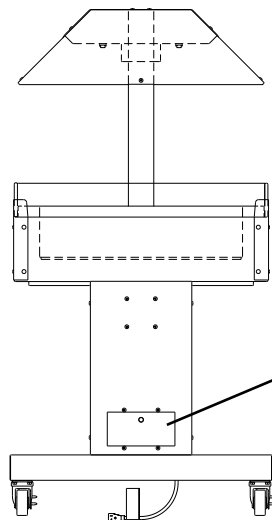

Item #	Description	Function
1	Temperature Control Knob	Controls the temperature of the warmer well.
2	Light / Top Heat Switch	Turns the power to the upper canopy heaters and lights on or off.

Merchandiser Startup and Preheating

1. Plug of the power cord into a receptacle that matches the power rating specified on the rating tag.
2. Open the control access hinged door.
3. Turn the Temperature Control Knob to the number 5 position.
4. Move the Light/Top Heat switch to the On position.
5. Close and latch the control access hinged door.
6. Allow the merchandiser to preheat for 30 minutes before loading it with product.

Temperature Adjustment

After loading the unit with product, it may be necessary to adjust the temperature control knob in order to maintain the proper internal temperature for the product on display. The temperature control knob should be set to the lowest possible number that will maintain the proper product temperature.

Operational Guidelines

- Food internal temperature should be a minimum of 175°F [80°C] when being placed in the unit.
- Foods loaded in first should be served first as much as is practical.
- Check Federal and State Health and Sanitation Regulations for internal temperature required for holding cooked foods for sale. Maintaining these temperatures often tends to continue to cook certain products. Therefore, smaller amounts of bulk foods should be displayed at non-peak periods and the warmer refilled as needed.

NOTICE

This equipment is designed to hold foods for a short period of time only.

Merchandiser Shutdown

1. Remove all Food products from the merchandiser.
2. Open the control access hinged door.
3. Turn the Temperature Control Knob to the Off position.
4. Move the Light/Top Heat switch to the Off position.
5. Close and latch the control access hinged door.
6. Allow the merchandiser to cool to 150°F [65°C] or below and clean as instructed below.

Installation



WARNING Serious injury, equipment damage or death could result if attempting to install this oven. Ensure that an authorized BKI service agent install the oven.

Unpacking and Handling

It is the owners' responsibility to file all freight claims with the delivering truck line. Inspect all cartons and crates for damage as soon as they arrive. If damage to cartons or crates is found, or if a shortage is found, note this on the bill of lading (all copies) prior to signing.

If damage is found when the equipment is opened, immediately call the delivering truck line and follow up the call with a written report indicating concealed damage to your shipment. Ask for an immediate inspection of your concealed damage item. Packaging material **MUST** be retained to show the inspector from the truck line.

Remove all packing from the interior and exterior of the merchandiser.

Location and Placement

Move the merchandiser to a permanent location and lock the swivel casters before using.

Electrical Information



WARNING Electrocutation, equipment failure or property damage could result if an unlicensed electrician performs the electrical installation. Ensure that a licensed electrician perform the electrical installation in accordance with local codes, or in the absence of local codes, with the National Electrical Code, ANSI NFPA 70-20XX.

This merchandiser is supplied with a 3-prong grounding electrical plug. The plug should be connected directly to a matching 3-prong receptacle. Do not cut or remove the grounding prong from the cut.

The electrical circuit to which the merchandiser is connected must have a current capacity greater than or equal to the merchandiser current rating found on the rating tag.

Specifications

MM-4

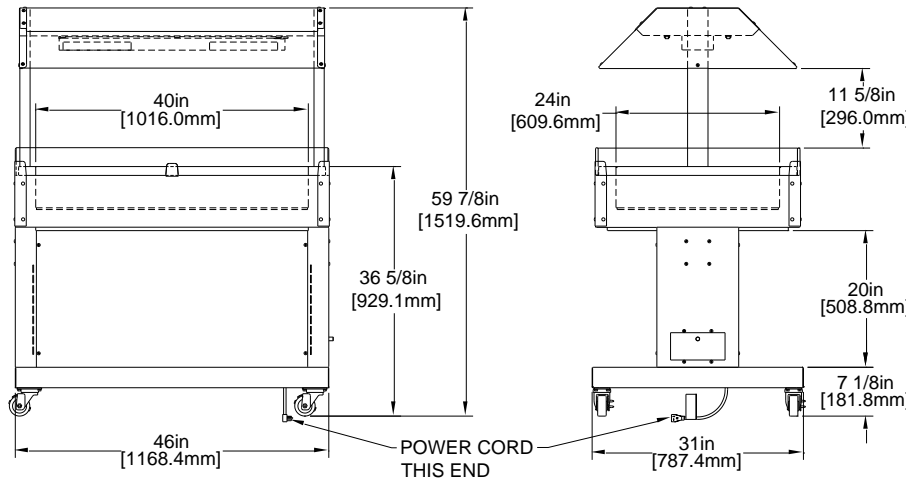

Electrical Specifications

Model: MM-4
1Ph + Gnd, 60Hz

Volts	Amps	kW	Breaker
120	12.5	1.5	20
220	7.9	1.7	10
240	7.8	1.9	10

Model: MM-6
1Ph + Gnd, 60Hz

Volts	Amps	kW	Breaker
120	17.8	2.1	30
220	11.4	2.4	20
240	11.2	2.7	20

MM-6

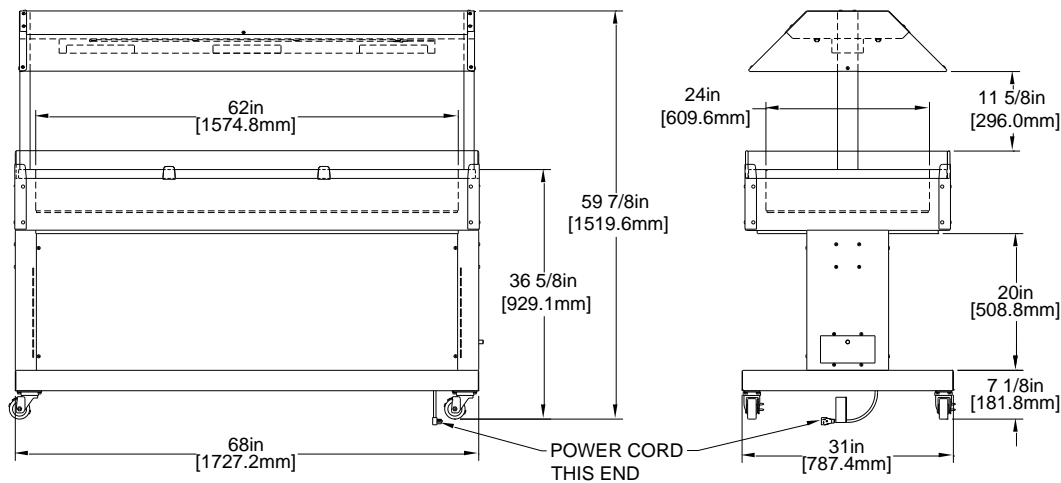

Mechanical Specifications					
Uncrated			Crated		
Dimension	MM-4	MM-6	Dimension	MM-4	MM-6
Height	59 7/8 in. [1521 mm]	59 7/8 in. [1521 mm]	Height	68 in. [1727 mm]	68 in. [1727 mm]
Width	46 in. [1168 mm]	68 in. [1727 mm]	Width	60 in. [1524 mm]	80 in. [2032 mm]
Depth	31 in. [787 mm]	31 in. [787 mm]	Depth	46 in. [1168 mm]	46 in. [1168 mm]
Floor Space	9.9 sq. ft. [0.92 m ²]	14.6 sq. ft. [1.36 m ²]	Floor Space	19.2 sq. ft. [1.78 m ²]	25.6 sq. ft. [2.37 m ²]
Weight	255 lb. [116 kg]	300 lb. [136 kg]	Weight	380 lb. [172 kg]	450 lb. [204 kg]

Maintenance



Failure to comply with the maintenance below could result in a serious accident or equipment damage.



Failure to remove power from this unit before performing maintenance may cause severe electrical shock. This unit may have more than one disconnect switch.

Scheduled Maintenance

Cleaning (Daily)

The merchandiser must be cleaned at the end of each business day. It is easier to clean while still warm. Cleaning is not only necessary for sanitary reasons, but will increase sales appeal and maximize operating efficiency.



Failure to remove power from this unit may cause severe electrical shock. This unit may have more than one disconnect switch.



Always wear appropriate personal protection equipment (goggles, rubber glove & long sleeved garments) when cleaning the oven to guard against possible injury.

Using abrasive cleaners will damage the cabinet finish. Use only a mild soap and water solution or approved cleaner.

DO NOT USE OVEN CLEANER on this machine. Caustic cleaners will cause damage to the machine.

NEVER USE A WATER HOSE OR A STEAM CLEANER TO WASH THIS UNIT. Excess water can get into the interior of the cabinet and cause damage.

BKI Approved Cleaning Solutions

ECOLAB Greasestrip Plus
Proctor & Gamble DCT Oven Cleaner
J. Wilson Marketing Combi Brite Cleaner

1. Remove all food from the merchandiser.
2. Open the control access hinged door.
3. Turn the Temperature Control Knob to the Off position.
4. Move the Light/Top Heat switch to the Off position.
5. Close and latch the control access hinged door.
6. Allow the merchandiser to cool to 150°F [65°C] or below and clean as instructed below.
7. Unplug the cord from the receptacle.
8. Remove any residue from the merchandiser.
9. Clean the outside and inside of the merchandiser with warm water, a sponge and approved cleaner which is authorized for use on food surface areas.
10. Wipe the outside and inside of the merchandiser dry with a soft, clean cloth.

Troubleshooting

Refer to the table below for troubleshooting information.

Problem	Cause	Possible Solution
Merchandiser will not turn on.	Oven power plug is disconnected.	Plug unit into mating receptacle.
	Problem with building power supply	Check circuit breaker at building power panel. If problem persists, contact BKI service agent for corrective action.
	Power supply cord has been damaged.	Contact an authorized BKI service agent for corrective action.
	Failed internal component.	Contact an authorized BKI service agent for corrective action.
Merchandiser does not heat.	Improper control settings.	Reset the control.
	Failed internal component.	Contact an authorized BKI service agent for corrective action.
Lights do not illuminate when the power is on.	Failed internal component.	Contact an authorized BKI service agent for corrective action.

Accessories

WELL RISERS-

FB64242210- MM4

FB64265910- MM6 (2 required)

BREAD RACKS-

AN64267800- MM4

AN64267900- MM6

BREAD BOX-

AN6426700- MM4 & 6



Wiring Diagrams

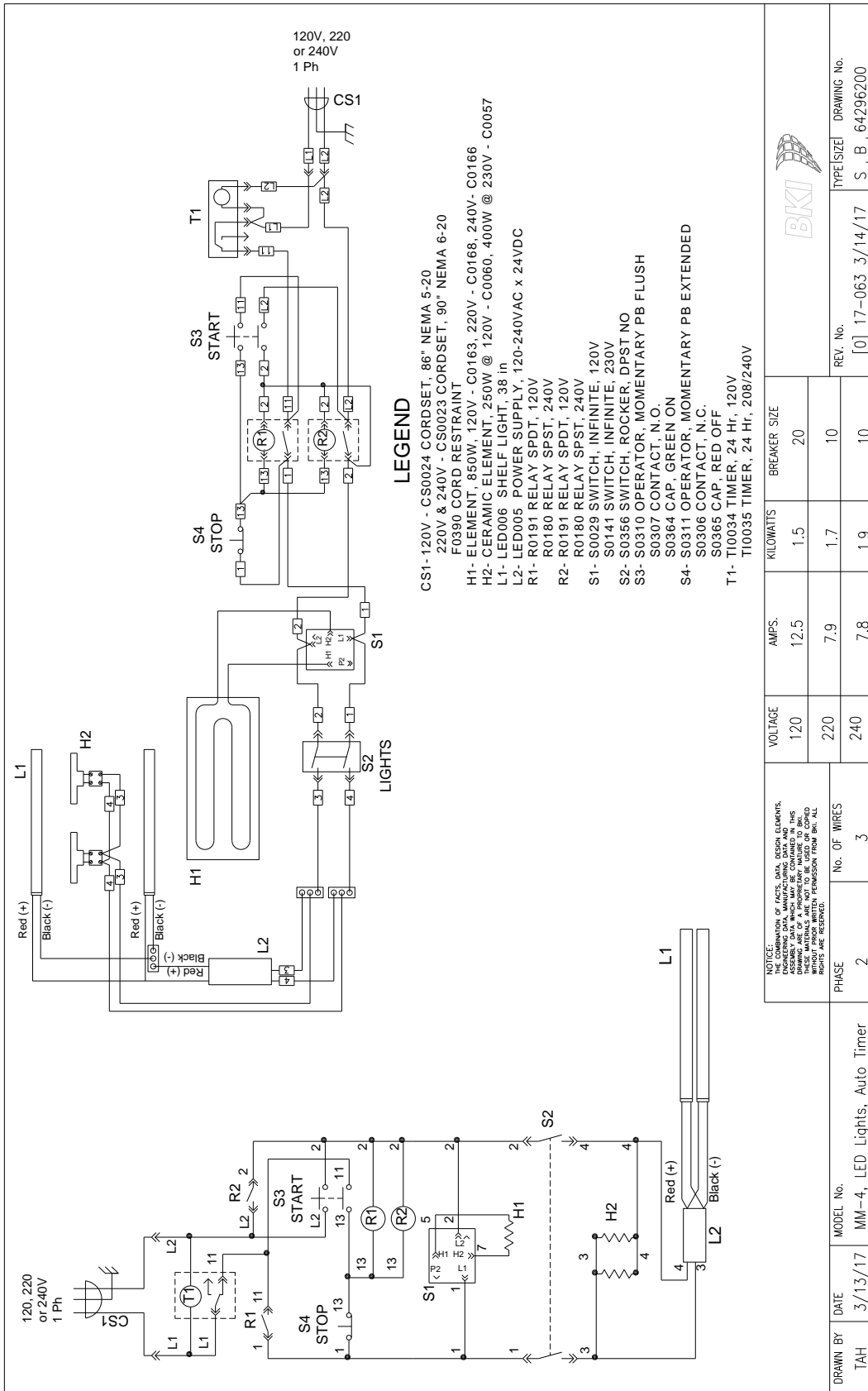

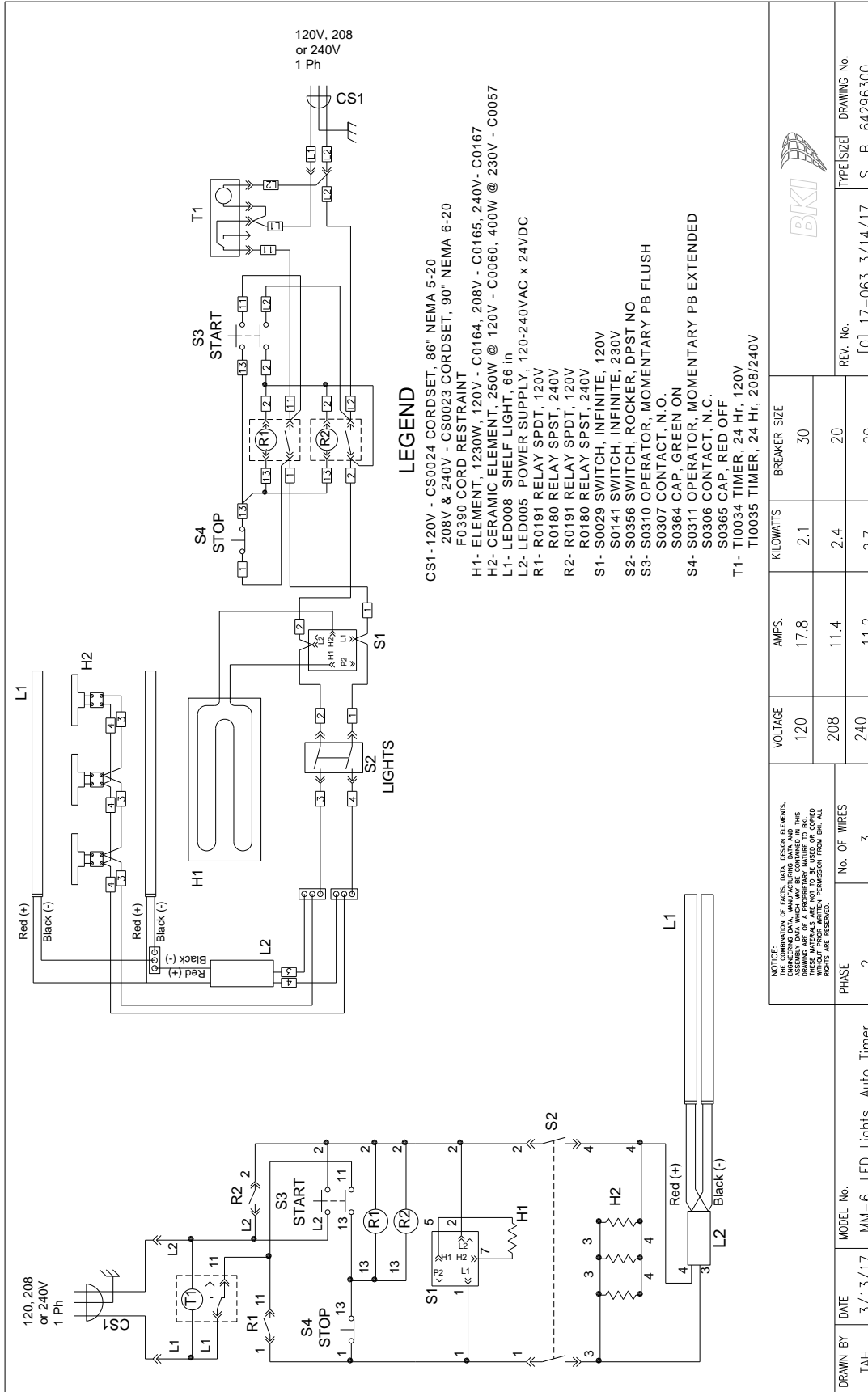

Notes



2812 Grandview Dr., Simpsonville, S.C. 29680, USA
<http://www.bkideas.com>

Made and printed in the U.S.A

SS-OM-063.02

Revised 9/26/18

