

Hussmann® Impact™ Hot Food Merchandiser

MODEL WDCHI, SSWHI, TSWHI, CSWHI
Installation & Operation Manual
Serial Numbers 121736 and Higher



Fresh ideas in foodservice equipment

Warranty Information

LIMITED ONE YEAR WARRANTY

BKI (The "Company") warrants to the original purchaser/user, that at time of shipment from the Company factory, this equipment will be free from defect in materials and workmanship. Written notice of a claim under this Warranty must be given within **ONE YEAR AND THREE MONTHS** from date of shipment from the factory. Defective conditions caused by abnormal use or misuse, lack of maintenance, damage by third parties, alterations by unauthorized personnel, acts of God, failure to follow installation instructions or any other events beyond the control of the company will **NOT** be covered under Warranty. The obligation of the Company under this Warranty shall be limited to repairing or replacing (at the option of the company) any part that is defective in reasonable opinion of the Company. The user will have the responsibility and expense of removing and returning the defective part to the Company as well as the cost of reinstalling the replacement or repaired part.

IN NO EVENT SHALL THE COMPANY BE LIABLE FOR LOSS OF USE, LOSS OF REVENUE OR LOSS OF PRODUCT OR PROFIT OR FOR INDIRECT OR CONSEQUENTIAL DAMAGES INCLUDING BUT NOT LIMITED TO, FOOD SPOILAGE OR PRODUCT LOSS. WARRANTY DOES NOT COVER GLASS BREAKAGE. THE ABOVE WARRANTY IS EXCLUSIVE AND ALL OTHER WARRANTIES, EXPRESS OR IMPLIED, ARE EXCLUDED INCLUDING THE IMPLIED WARRANTIES OF MERCHANTABILITY AND FITNESS FOR A PARTICULAR PURPOSE. THIS WARRANTY SHALL APPLY ONLY WITHIN THE CONTINENTAL UNITED STATES, ITS TERRITORIES, AND POSSESSIONS AND IN CANADA.

LIMITED NINETY DAY LABOR WARRANTY

All labor necessary to repair or replace factory defective parts will be performed, without charge, to the end user, by service personnel of a **BKI** Authorized Distributor during the first ninety days after the date of installation of the new equipment.

Replacement parts: Any appliance replacement part, except lamps and fuses, which proves to be defective in material or workmanship within 90 days from date of original installation will be repaired or replaced without charge F.O.B. Factory, Simpsonville, S.C. or F.O.B. authorized distributor.

Table of Contents

Table of Contents	1
Introduction	2
Safety Precautions	2
Safety Signs and Messages	2
Safe Work Practices	3
Safety Labels	5
Operation	6
Controls	6
Preheating	6
Temperature Adjustment	7
Operational Guidelines	7
Unit Shutdown	7
Installation	8
NSF Certification	8
Location	8
Shipping Damage	9
Shipping Braces	9
Shipping Rider	9
Case Leveling	10
Preparation	10
Leveler Adjustment	10
Glass Positioning	11
Raising/Lowering Glass Using Adjustment Bolt	13
Joining Instructions	16
Wiring	22
Installing Splashguard And Lower Front Panel	23
Splashguards	23
Lower Front Panel	23
Installing Bottom Rear Panel	24
Maintenance	25
Scheduled Maintenance	25
Cleaning	25
Troubleshooting	26
Notes	27

Introduction

Congratulations! You have chosen a Hot Food Merchandiser. It consists of thermostatically controlled hot food waterless wells, canopy heaters/lighting, customer side curved glass service door with lift hardware, operator side service doors, bumpers, splashguards and electronic controls.

This unit is manufactured by BKI which assures you of the finest in design and engineering -- that it has been built with care and dedication -- using the best materials available. Attention to the operating instructions regarding proper installation, operation, and maintenance will result in long lasting dependability to insure the highest profitable return on your investment.

NOTICE

PLEASE READ THIS ENTIRE MANUAL BEFORE OPERATING THE UNIT. If you have any questions, please contact your BKI Distributor. If they are unable to answer your questions, contact the BKI Technical Service Department, toll free: 1-800-927-6887. Outside the U.S., call 1-864-963-3471.

This unit is to be sealed to the floor after installation to conform to NSF requirements. (Dow Corning RTV #732 Multi purpose Sealant.)

Safety Precautions

Always follow recommended safety precautions listed in this manual. Below is the safety alert symbol. When you see this symbol on your equipment, be alert to the potential for personal injury or property damage.



Safety Signs and Messages

The following Safety signs and messages are placed in this manual to provide instructions and identify specific areas where potential hazards exist and special precautions should be taken. Know and understand the meaning of these instructions, signs, and messages. Damage to the equipment, death or serious injury to you or other persons may result if these messages are not followed.

▲ DANGER

This message indicates an imminently hazardous situation which, if not avoided, will result in death or serious injury.

▲ WARNING

This message indicates a potentially hazardous situation, which, if not avoided, could result in death or serious injury.

▲ CAUTION

This message indicates a potentially hazardous situation, which, if not avoided, may result in minor or moderate injury. It may also be used to alert against unsafe practices.

NOTICE

This message is used when special information, instructions or identification are required relating to procedures, equipment, tools, capacities and other special data.

Safe Work Practices



Beware of High Voltage

This equipment uses high voltage. Serious injury can occur if you or any untrained or unauthorized person installs, services, or repairs this equipment. Always Use an Authorized Service agent to Service Your Equipment



Keep this manual with the Equipment

This manual is an important part of your equipment. Always keep it near for easy access.

If you need to replace this manual, contact:

BKI

Technical Services Department
P.O. Box 80400
Simpsonville, S.C. 29680-0400
Or call toll free: 1-800-927-6887
Outside the U.S., call 864-963-3471



Protect Children

Keep children away from this equipment. Children may not understand that this equipment is dangerous for them and others.

NEVER allow children to play near or operate your equipment.

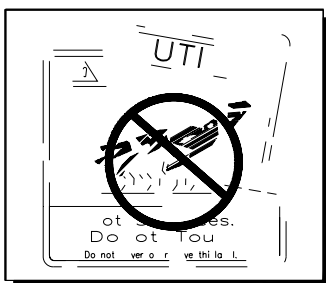

Keep Safety Labels Clean and in Good Condition

Do not remove or cover any safety labels on your equipment. Keep all safety labels clean and in good condition. Replace any damaged or missing safety labels. Refer to the Safety Labels section for illustration and location of safety labels on this unit. If you need a new safety label, obtain the number of the specific label illustrated on page 5, then contact:

BKI

Technical Services Department
P.O. Box 80400
Simpsonville, S.C. 29680-0400
Or call toll free: 1-800-927-6887
Outside the U.S., call 864-963-3471

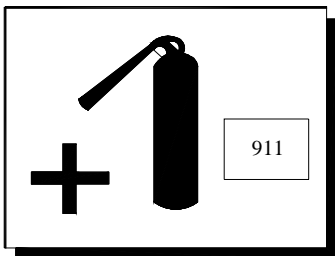

Be Prepared for Emergencies

Be prepared for fires, injuries, or other emergencies.

Keep a first aid kit and a fire extinguisher near the equipment. You must use a 40-pound Type BC fire extinguisher and keep it within 25 feet of your equipment.

Keep emergency numbers for doctors, ambulance services, hospitals, and the fire department near your telephone.

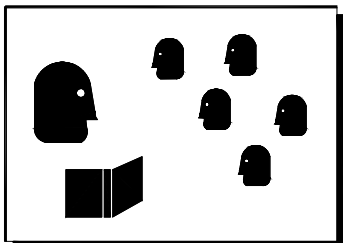





Know your responsibilities as an Employer

- Make certain your employees know how to operate the equipment.
- Make certain your employees are aware of the safety precautions on the equipment and in this manual.
- Make certain that you have thoroughly trained your employees about operating the equipment safely.
- Make certain the equipment is in proper working condition. If you make unauthorized modifications to the equipment, you will reduce the function and safety of the equipment.

Safety Labels

HI0017

 KEEP FINGERS AND OBJECTS CLEAR OF THIS AREA, WHEN CLEANING GLASS
  MANTENGA SUS DEDOS Y OTROS OBJETOS FUERA DE ESTA AREA, CUANDO LEVANTA EL VIDRIO.
  ELOIGNER DOIGTS ET AUTRES OBJETS DE CE SECTEUR DURANT L'OUVERTURE DES VITRINES
 

0425327

HI0018

IMPORTANT

REPLACE CYLINDERS USING TOOL #0425326
CYLINDER RODS MUST POINT DOWN.

IMPORTANTE

REPLACE LOS CILINDROS USANDO LA HERRAMIENTA #0425326. LOS VASTAGOS DE LOS CILINDROS DEBEN APUNTAR HACIA ABAJO.

IMPOR TANT

UTILISER L'OUTIL #0425326 POUR REMPLACER LES CYLINDRES. LE BOUT ETROIT DU CYLINDRE DOIT ETRE VERS LE BAS.



TOOL PART NO.
0425326

0425328

(NEAR CYLINDER RODS)

N0451

 CAUTION

THIS MACHINE CAN BE INSTALLED EITHER 1 OR 3 PHASE. PLEASE NOTE HOOK-UP BEFORE APPLYING POWER.

L1-BLACK
L2-RED
L3-BLUE

3 PHASE CONNECTION

L1 L3 L2

1 PHASE CONNECTION

N0451

(IN REAR OF UNIT)



N0516

This machine is intended for use with pre-packaged foods only.

N0516

(IN REAR OF UNIT)

N0202



DANGER

HIGH VOLTAGE.
 Turn power off before servicing.
 May have more than one disconnect switch.
Do not cover or remove label. N0202

(IN REAR OF UNIT)

Operation

Controls

The merchandiser controls are shown in the figure below. The POWER switch turns the power supply to the unit on and off. The LIGHTS switch turns the lights in the unit on and off. The POWER switch must be turned on for the lights to operate.

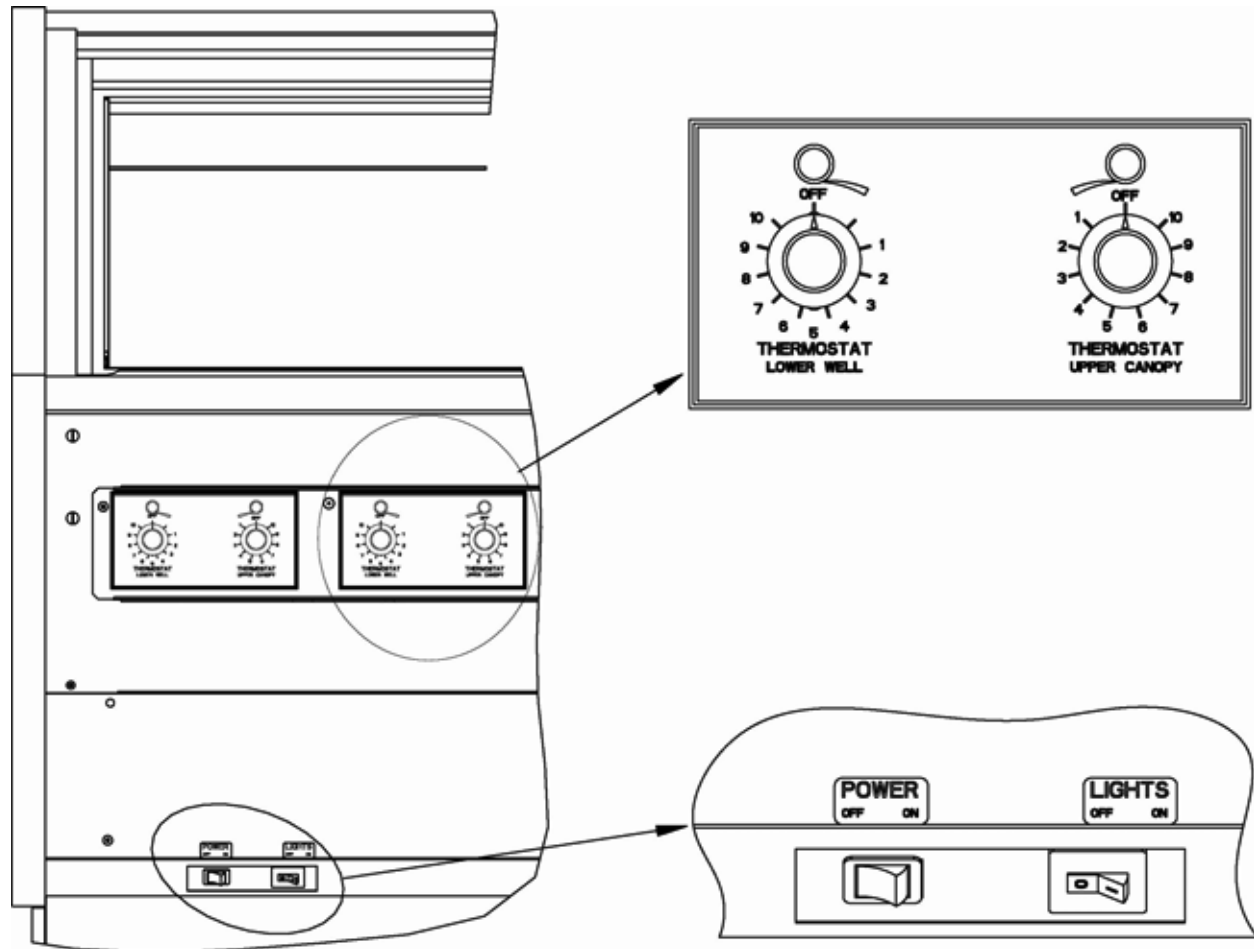

The well and canopy heaters for each well section of the unit are individually controlled as shown in figure above. (TSWHI units – the well and shelf heaters are individually controlled.) With the indicator on the control knob turned to the 12 o'clock position as shown, the heaters produce no heat.

To increase the temperature of the lower well heater, rotate its control knob clockwise. Likewise, to increase the temperature of the canopy heater, rotate its control knob counterclockwise.

Preheating

To preheat the equipment, position the temperature control knobs on each well to the number 5. You should allow the equipment to preheat for a minimum of 30 minutes before loading it with product.

Each well is equipped with a pilot light indicator. The pilot light indicator is designed to turn **OFF** when the well reaches set temperature. During operation the pilot light indicator will turn **OFF** and **ON** as the well maintains proper temperature.

Check Federal and State Health and Sanitation Regulations for internal temperature required for holding cooked foods for sale. Maintaining these temperatures often tend to allow continued cooking of certain products. Therefore, smaller amounts of bulk foods should be displayed at non-peak periods and the warmer refilled as needed.

All meats and vegetables should be preheated to 160 degrees F. before being placed in the case.

A screen liner can be used in the bottom of the display pans that are used for holding meats. This will keep meats from sticking to the bottom of the pans.

Temperature Adjustment

After placing the product into the equipment, it may be necessary to adjust the temperature adjustment knobs in order to maintain the proper internal temperature for the product on display. A thermometer should be used to read the internal temperature of each product. The temperature control knobs should be set to the lowest possible number that will maintain the proper product temperature.

Operational Guidelines

- Keep portable meat thermometers on hand. Check the food temperatures hourly.
- Rotate the food products. Foods loaded in first should be served first as much as is practical.
- Foods held for long periods of time are more difficult to maintain at proper temperature. Also, freshness and product quality diminish if foods are held too long. Most areas of the country have sanitation regulations governing how long foods can be held. Make certain to check with your local authorities.

Unit Shutdown

Remove all food pans holding the food product from the equipment. Turn **OFF** the power to the wells by positioning the temperature knobs to the **OFF** position. Turn **OFF** the lights. After the temperature has cooled down, remove any residue from the wells and clean the equipment thoroughly.

Installation

NSF Certification

This merchandiser is manufactured to meet ANSI/National Sanitation Foundation (NSF®) Standard #7 requirements. Proper installation is required to maintain certification.

Location

This merchandiser is designed for displaying products in air-conditioned stores where temperature is maintained at or below the ANSI/NSF-7 specified level and relative humidity is maintained at or below 55%.

This merchandiser is sensitive to air disturbances. Air currents passing around the merchandiser will seriously impair its operation. Do NOT allow air conditioning, electric fans, open doors or windows, etc. to create air currents around the merchandiser.

The product should always be maintained at 145° F to maximize its display life.

CAUTION Read before raising front glass.

The top cylinders, which allow the raising and lowering of this glass, have been carefully installed and tested for the proper tension before shipment. However, during shipment and storage, the lubricant inside the cylinders may have settled. This settling can cause excessive or uneven tension on the glass to the point of breakage.

To avoid any damage, please do the following before completely raising the front glass.

1. Slowly raise and lower each glass section 6 times to a height of 6 in. (152 mm).
2. Increase the height to about 12 in. (305 mm) and raise and lower the glass 6 times.
3. Then raise the glass to the full extension and lower.

This should release any settled lubricant in the cylinders and prevent any stress on the front glass.

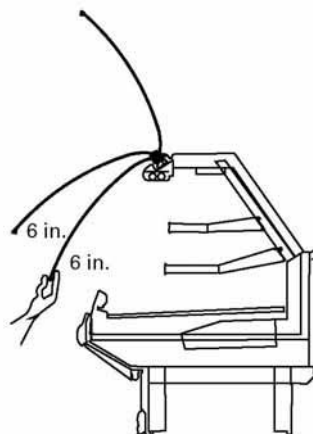

WARNING

Do NOT remove shipping braces until the merchandisers are positioned for installation.

Shipping Damage

YOU are responsible for filling all freight claims with the delivering truck line. Inspect all cartons and crates for damage as soon as they arrive. If damage to cartons or crates is found, or if a shortage is found, note this on the bill of lading (all copies) prior to signing.

If damage is found when the equipment is opened, immediately call the delivering truck line and follow up the call with a written report indicating concealed damage to your shipment. Ask for an immediate inspection of your concealed damage item. Packaging material **MUST** be retained to show the inspector from the truck line.

CAUTION

Do not walk or put heavy object on top of merchandisers.

Damage to the merchandisers and serious personal injury could occur. Merchandisers ARE NOT STRUCTURALLY DESIGNED TO SUPPORT EXCESSIVE EXTERNAL LOADING such as the weight of a person. Do not place heavy objects on the case.

Shipping Braces

Note: Be careful not to damage the factory-installed end while moving the case. Make sure that tools are positioned past the end and beneath the merchandiser's support bar.

Move the fixture as close as possible to its permanent location and then remove all packaging and shipping braces. Check for damage before discarding packaging. Remove all separately packed accessories such as kits, and shelves.

Remove all nut retainers used with shipping braces. NSF certification requires the use of ANSI Standard nuts and bolts with not more than 2 threads showing after installation.

Shipping Rider

Each case is shipped on a rider to protect factory-installed legs, and to make positioning the case easier. Remove the rider after the case has been positioned.

Note: Once the rider is removed, the case must be lifted –NOT PUSHED– to reposition.

To remove the rider, remove screws attaching each leg to rider. Remove screws holding rider cross-members, then slide cross-members out from between sides. Once cross-members are out, slide the sides out.

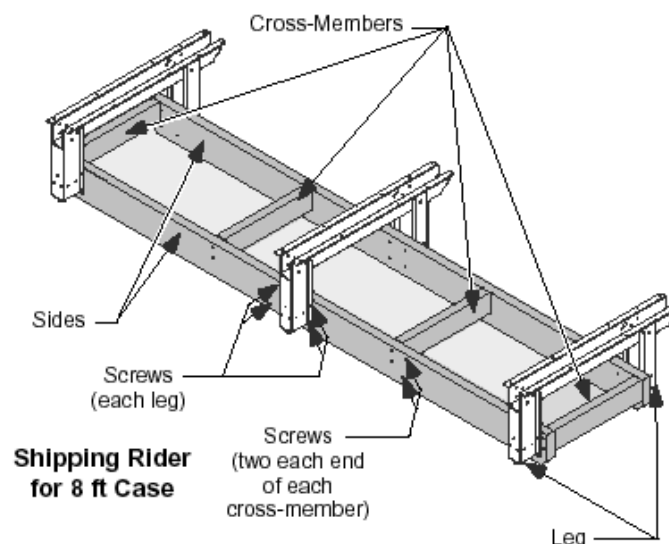

Case Leveling

Merchandisers must be installed level to ensure proper operation. During all steps of setting, joining and leveling cases, close attention to glass position and operation must be maintained. Please review all steps and photos before making any adjustments. **DO NOT** make any glass adjustments until individual case is set and level.

Preparation

1. Using store blueprints, measure off and mark on floor the exact dimensions/locations of the case footprint.
2. Snap a chalk line for the front and rear positions of the base legs.
3. Mark the location of each joint from front to back lines.
4. **FLOORS ARE NOT LEVEL!!!** When working with two or more cases to be joined, the whole lineup must be leveled on the same plane, left to right and front to back. This means that the entire lineup must be brought up to the level of the highest case in the lineup.

Along the lines previously marked, find the highest point of the floor by:

- Walking the floor and noticing any dips or mounds;
- Using a string level; and
- Using a transit.

Leveler Adjustment

Position the first case at the highest point. Set a long level (4 ft [1220 mm] or more) on the upper front panel of the case. Use an open-end wrench to turn leg levelers until the case is level from end to end and from front to back. Check all 6 legs on 8 ft (2438 mm) cases, or 8 legs on 12 ft (3658 mm) cases.

Note: To avoid removing concrete flooring, begin lineup leveling from the highest point of the store floor

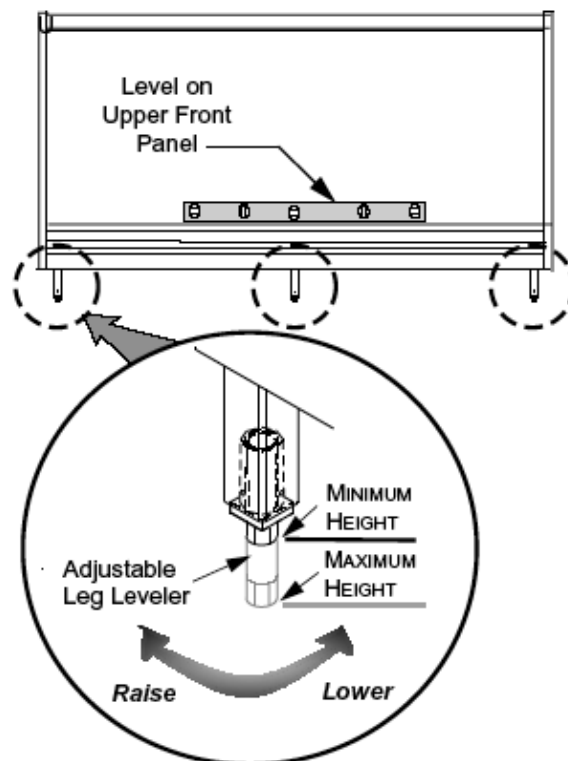

Attention to glass position is critical during the leveling process.

Adjusting leg levelers will affect the position of the glass. Make certain that the glass is square with the case, avoiding interference with other glass and case ends.

If the glass is still out of alignment, refer to the following *Glass Positioning* instructions.

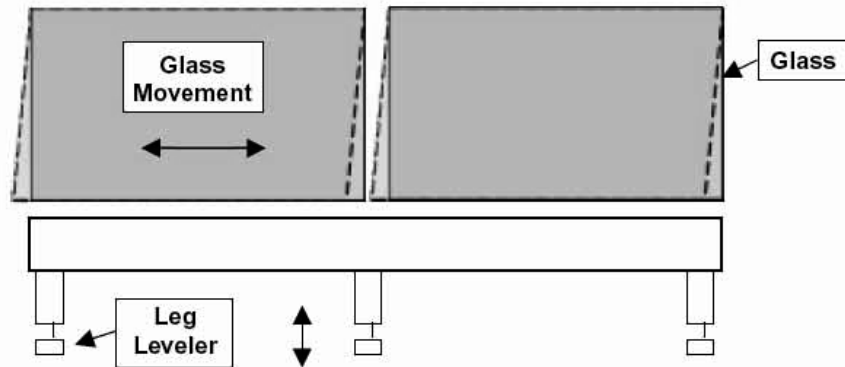

CAUTION Glass must be properly supported when adjusting.

Glass Positioning

Follow the procedures below to improve the opening and closing of the case front glass.

1. Ensure the case has been leveled according to the Case Leveling procedure.
2. Ensure that the glass handle is installed correctly.

Verify the glass is bottomed out the length of the handle. A bowed handle indicates the glass may not be bottomed out at the center of the handle.

The handle must be removed before it can be repositioned. The handle is held in place with silicone that must be completely removed from the handle and the glass. Remove the handle by pulling it away from the glass (do not use tools to pry this loose). A damaged or bent handle must be replaced. Apply new silicone into the handle and firmly press onto the glass.



3. Ensure that the glass is seated in the clamp hardware correctly.

Verify glass is bottomed out in clamp hardware.

If the glass is not bottomed out in the clamp hardware it can be re-positioned as follows:



- a. Remove the glass and clamp hardware from the case by opening the glass and loosening set screws in hinge, (Metric 3 millimeter set screws).

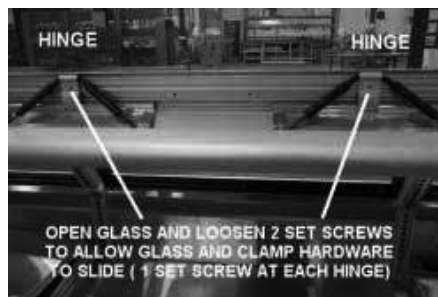

- b. Slide the glass and clamp hardware to the side, out of the hinges, and lay them on an appropriate work surface.

Note: adjacent glass must be closed.

- c. Loosen the 8 set screws on the underside of the clamp hardware.
 - d. Push the clamp hardware onto the glass until bottomed out.
 - e. The clamp hardware must overhang the glass by an equal amount on each side.
 - f. Tighten set-screws and re-install on case.
4. Slowly open and close the glass to make sure that it is not hitting the end or adjacent glass. If the glass is hitting the end or adjacent glass it may not be positioned correctly from left to right. This can be adjusted as follows:



- a. Loosen the 2 screws holding the hinge to the clamp hardware (Metric 3 millimeter screws).
- b. Slide the clamp hardware to either side as needed.

- c. Tighten the screws and check glass for proper operation.
5. Slowly open and close the glass to make sure that it is still not hitting adjacent glass.

Each glass has been shipped with a flexible wiper gasket attached to each side. These are designed to overlap each other, sealing the gap between the glass and allowing side-to-side glass adjustment. After all glass has been adjusted as defined in Step 4, the flexible portion of one gasket at a joint may be trimmed with a razor knife. Be sure that the remaining wiper gasket seals the gap. Verify proper operation.

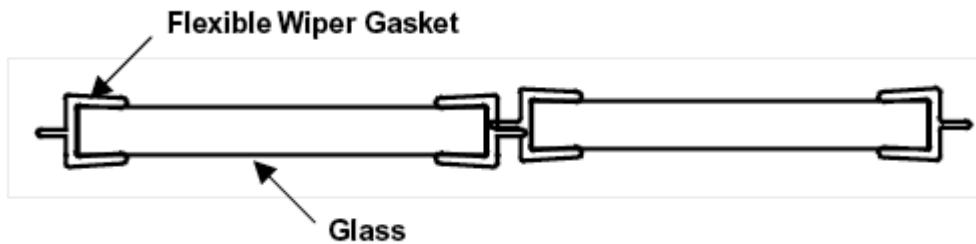

Raising/Lowering Glass Using Adjustment Bolt

If the glass still does not open or close correctly, adjustment of the top frame may be necessary.

This case is equipped with an adjustment bolt at the top rear of the case to raise or lower the glass. This allows for improvements in the glass operation and sealing. The following outlines how to access the adjustment bolt. The top must be free to move as the adjustment bolt is turned.

1. Loosen joining or end bolts at top of case, (2 at each end of case).



2. If caulk or silicone has been applied between case joints or ends in the top area it must be removed.
3. Remove rear doors.

4. Remove screws at top of rear doorframe. The bottom screws do not need to be removed.



5. Pull back the top of the doorframe approximately 2 inches. This will allow clearance for removal of the stainless steel top liner and trim pieces.



6. Some models have a Phillips truss head screw holding the stainless steel liner to the trim. These screws are visible from the rear of the case to the side of the door frame. These must be removed.
7. Remove stainless steel top liner by grabbing the rear flange and pulling back. Note: It is possible to access the adjusting bolt by using a small swivel socket without removing the stainless top liner. To do this, the stainless steel trim and foam noted in Step 8 must be removed.
8. Remove stainless steel trim pieces and foam insulation on each side of the doorframe.

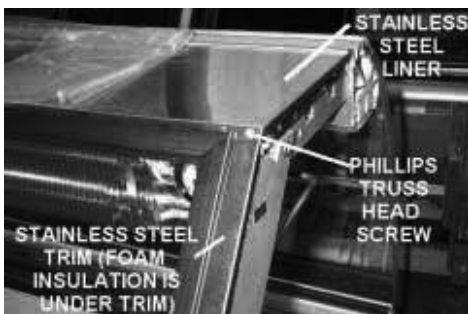

9. The set screw and adjusting bolt are now accessible.
 - The set screw must be backed out before turning the adjusting bolt, (1/8 inch set screw). The set screw serves as a positive stop.
 - The adjusting bolt should be turned no more than a half-turn before inspecting glass position and operation.
 - Turning the adjusting bolt clockwise will raise the front glass.
 - Turning the adjusting bolt counter-clockwise will lower the front glass.
 - Once the glass position is set, tighten the set screw (positive stop).

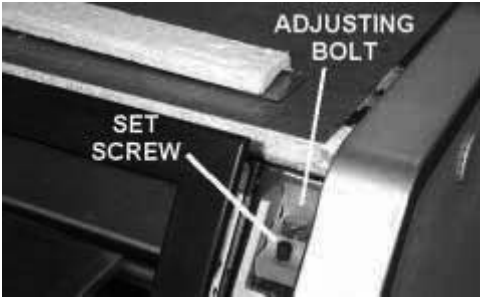

10. Once glass is positioned and operating correctly, re-install components and hardware removed.

Note: the doorframe is designed to have a tight fit. A putty knife between the top of the frame and the insulated panel will help guide it into position.

11. Re-apply caulk or silicone as required.

12. Verify glass is positioned and operating correctly.

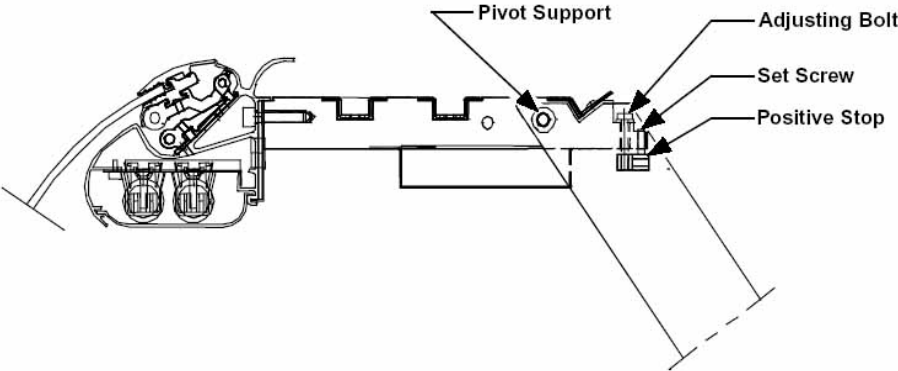

Joining Instructions

1. Install the Top Gasket Pad (Item 4 and DETAIL F) and apply Silicone (Item 3 and DETAIL H-a).

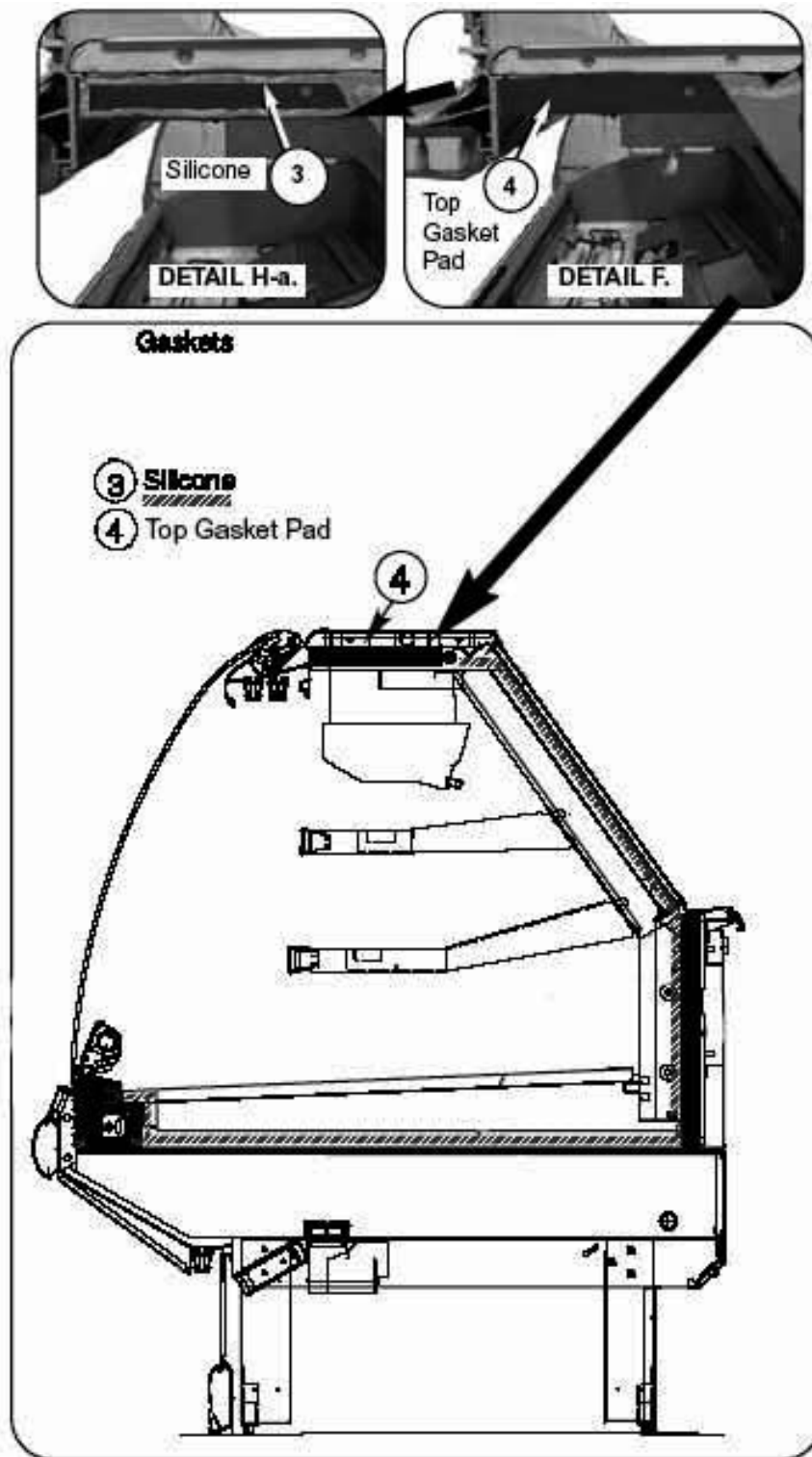

2. The complete lineup must be leveled to the highest point of the floor. After the first merchandiser has been set, position the second so the end frames touch.
 - a. Set a long level (4 foot or more) on the upper front panel of the merchandisers. Adjust case height by rotating the Adjustable Leg Leveler until the merchandisers are flush and level.
 - b. Also check each joint area to be sure that the panels of adjoining merchandisers are flush to each other.

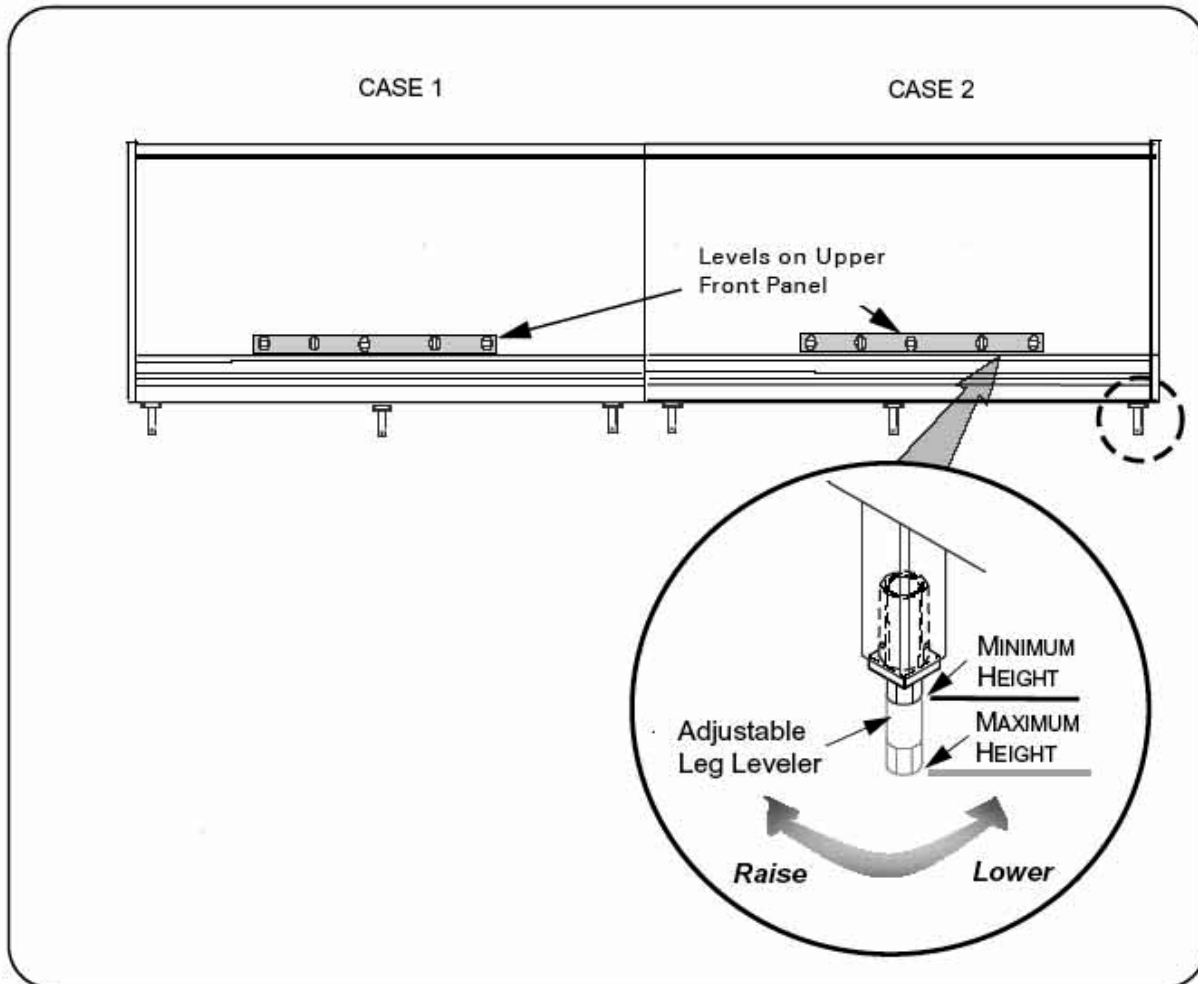

- Align the top extrusion and insert Joining Plate (Item 7).

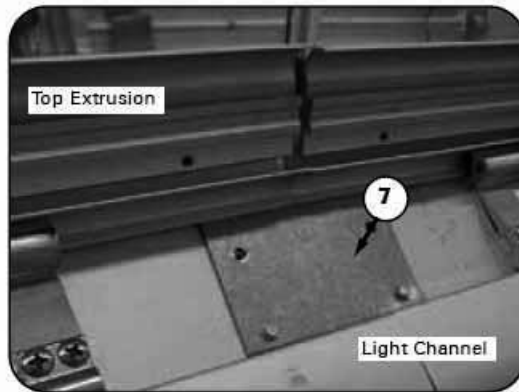

- Use 8-18 x 3/8 Truss Head SM Screws (Item 8) to fasten the plate using the predrilled pilot holes as shown below.

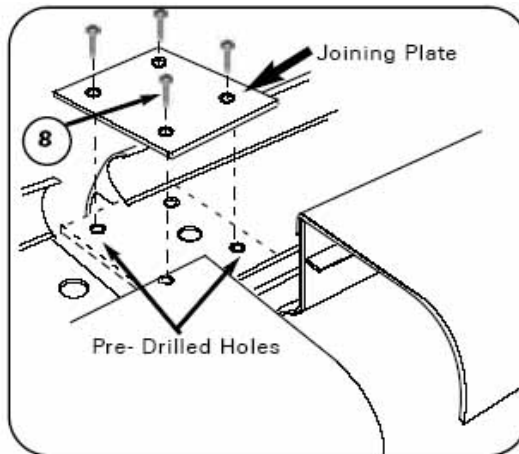

- Align the Rear Sill and attach Joining Bracket (Item 9) with 10-24 x 1/2 Washer Head Machine Screws (Item 10). Use only specified fasteners. Longer screws will penetrate the Rear Sill causing damage.

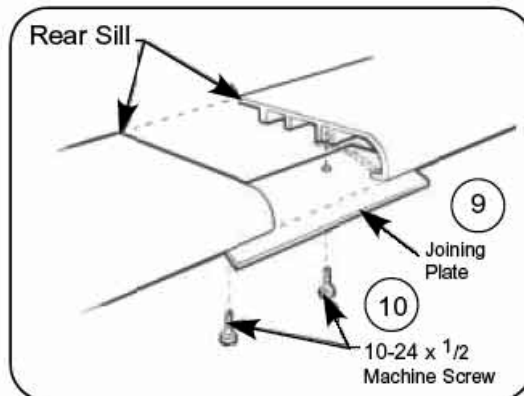

6. Bolt the cases together according to the sequence illustrated below.

Note: Make sure that no more than (2) threads are exposed when the cases are bolted together. If this does occur, the bolt should be shortened, replaced with a shorter bolt or capped off according to NSF specifications.



⚠ WARNING

Use caution when installing fasteners around wiring.

- a. Fasten the fronts together using 5/16-18 x 1 Hex Head Cap Screws, 5/16 Flat Washers and 5/16 Lock Washers.
- b. Fasten the rear of the cases together at two locations shown above using 5/16-18 x 1 Hex Head Cap Screws, 5/16 Flat Washers, 5/16 Lock Washers and 5/16-18 Hex Nut.
- c. Fasten the top rear of the cases together using 5/16-18 x 3 1/2 Cap Screws, 5/16 Flat Washers, 5/16 Lock Washers and 5/16-18 Hex Nut.

7. Apply a smooth continuous bead of silicone over the Exterior Top Joint (A.) of the cases. Continue sealing down the Rear Mullion Joint (B.) of the cases and finally seal the Rear Sill Joints (C.), as illustrated below.



8. Install the Splashguard Joint Support (Item 25) to the splashguard retainer using #8 x 1/2 Hex Head Sheet metal Screws (Item 26).

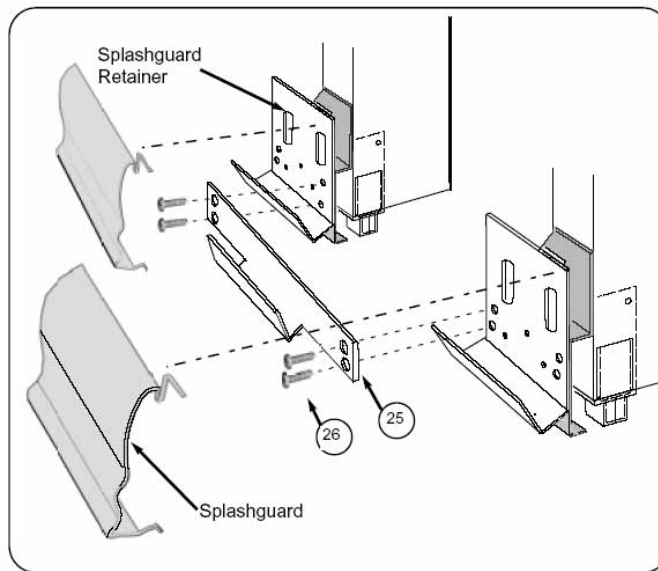

Wiring

⚠ WARNING

Electrocution, equipment failure or property damage could result if an unlicensed electrician performs the electrical installation. Ensure that a licensed electrician performs the electrical installation.

A wiring diagram for the specific model is shipped with the merchandiser. The wiring diagram provides electrical specifications, an electrical schematic and a parts list. Refer to this wiring diagram and the merchandiser serial number plate for electrical information.

Field wiring must be sized for the components amperes printed on the serial number plate. Actual ampere draw may be less than specified.

All electrical connections should be in compliance with the NEC and all applicable local codes by a licensed electrician. Refer to the wiring diagram furnished with your merchandiser for the electrical specifications.

Follow the steps below to connect the power supply to the merchandiser. Refer to the figure below.

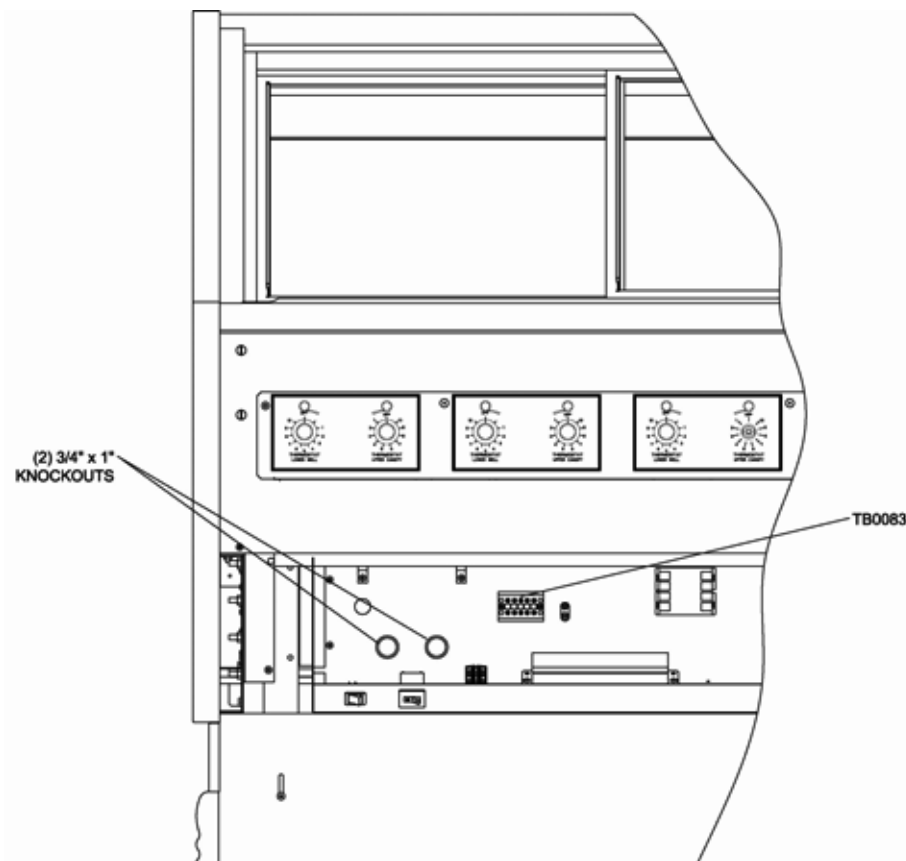

1. Remove the electrical raceway cover.
2. Two $\frac{3}{4}$ " x 1" knockouts are provided for routing of power supply wiring. Route power supply wiring through the knockout holes.
3. A power supply terminal block (TB0083) is located on the electrical raceway. Connect the wiring to power supply terminal block (TB0083) according to the schematic provided.
4. Reattach the electrical raceway cover.

Installing Splashguard And Lower Front Panel

Make certain that the end assemblies; end splashguards and end panels have been installed according to the End Kit instruction.

The splashguard and lower front panel are shipped inside each case. **After** merchandisers have been leveled, joined and electrical work has been completed, install the splashguard and lower front panel.

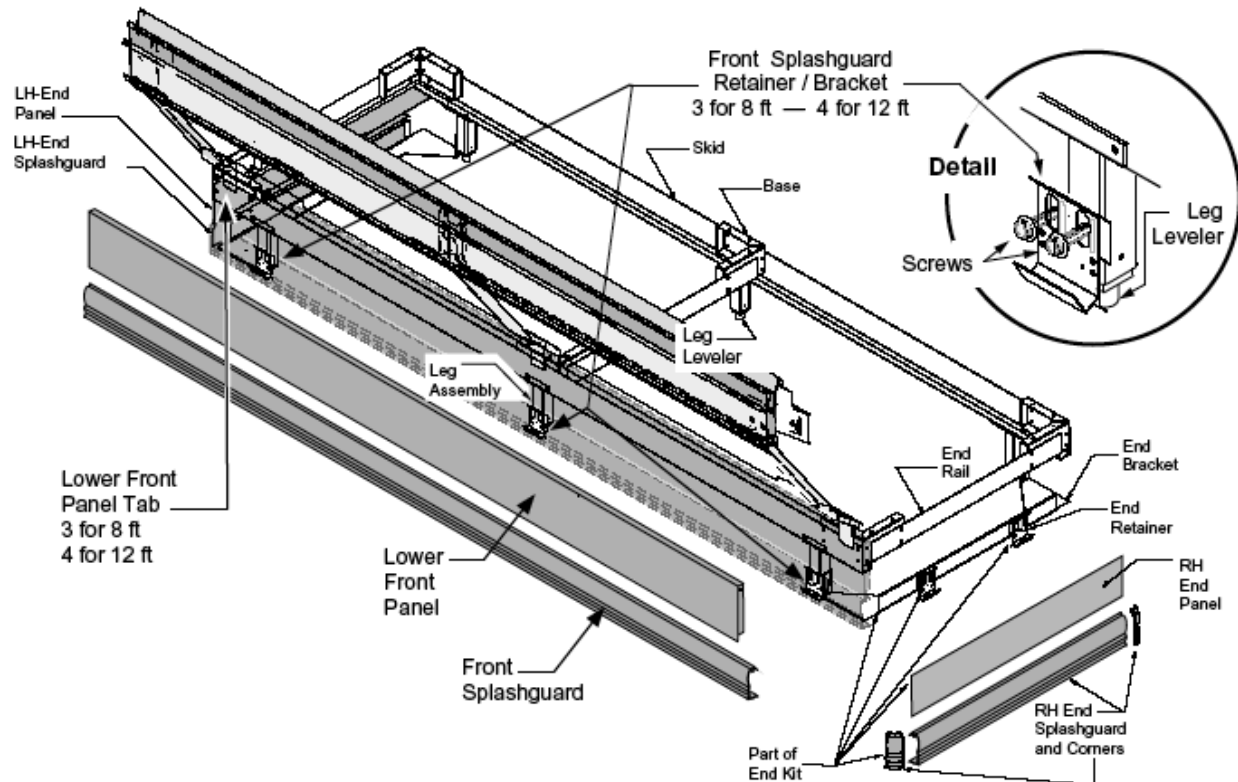

Splashguards

1. At front of merchandiser, attach a splashguard retainer/bracket to each leg with sheet metal screws.
2. Position top of splashguard over the top edge of the retainer/bracket as shown below.
3. Push the lower edge of the splashguard toward the bottom of the bracket until it snaps into place.

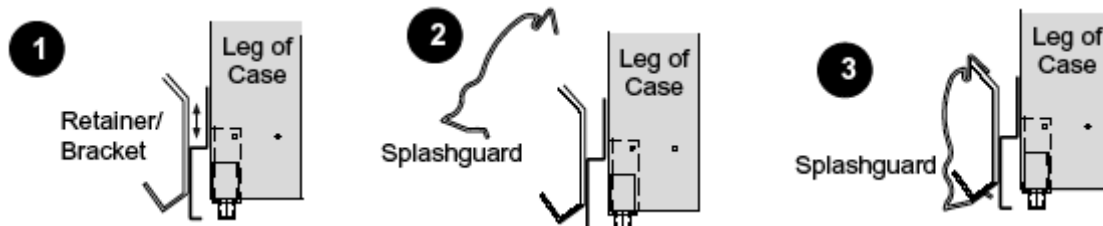

Lower Front Panel

1. Position the lower front panel with the top angled as shown in the illustration. Tabs extending from the upper front assembly are designed to fit into the slots on the top of the lower front panel.

2. Once the top is positioned, lift the panel up and drop it into the groove at the top of the splashguard.

Do not use additional fasteners or sealant to hold splashguards or panels in place. To meet NSF cleaning requirements, splashguards and panels must be removable without tools.

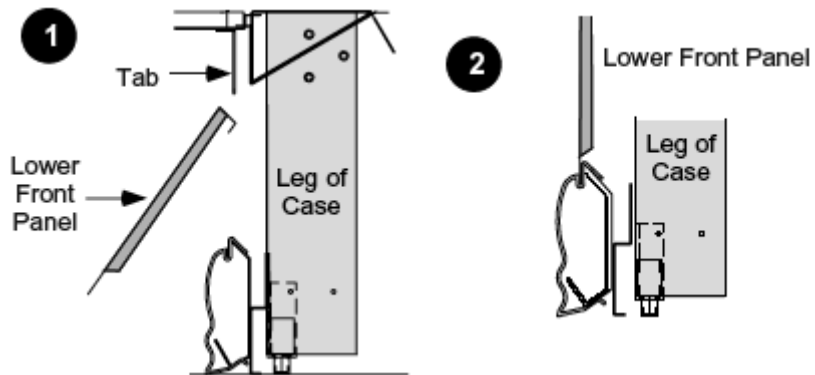

Installing Bottom Rear Panel

For fixed installation:

1. Align slots in bottom rear panel with center of legs.
2. Drive a hex head sheet metal screw through each slot into each leg.

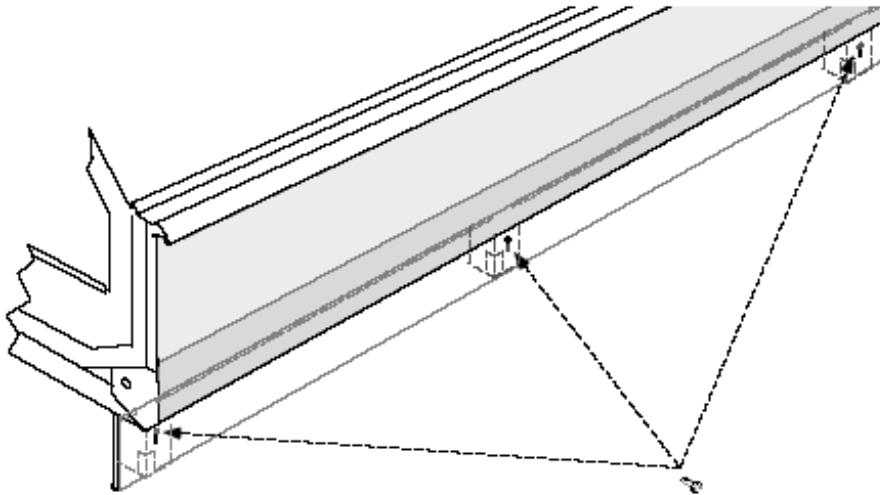

Maintenance

CAUTION

Failure to comply with the maintenance below could result in a serious accident.

WARNING

Electrocution, equipment failure or property damage could result if an unlicensed electrician performs electrical repair. Ensure that a licensed electrician performs electrical repair.

Scheduled Maintenance

Use the following table to help manage scheduled maintenance activities.

Frequency	Performed By	Part	Activity
Daily	User	Case	Clean the entire Case. Refer to the cleaning procedure below.

Cleaning

This unit should be cleaned at the end of each day. Use the following procedure:

DANGER

Failure to remove power from this unit may cause severe electrical shock. This unit may have more than one disconnect switch.

1. Turn the machine 'off' and allow it to cool down.
2. Remove any food pans.

CAUTION

Using abrasive cleaners may damage the cabinet finish. Use only a mild soap and water solution.

Never steam clean or get excess water in the interior of the cabinet as this can damage unit.

3. Use a mild soap and water solution to clean parts.
4. Sponge the inside and outside with a mild soap and water solution.
5. Wipe the parts and cabinet dry with a soft, clean cloth.

Troubleshooting

Refer to the table below for troubleshooting information.

Problem	Cause	Possible Solution
Electrical	No Power to the case.	Check circuit breaker or fuses at building power panel. If problem persists, contact an authorized BKI service agent for corrective action.
	Power switch is off.	Reset the power switch.
No Heat	Power switch is off.	Reset the power switch.
	Defective Heating Element.	Contact an authorized BKI service agent for corrective action.
	Defective Thermostat.	Contact an authorized BKI service agent for corrective action.
	Loose Wire or bad Connection.	Contact an authorized BKI service agent for corrective action.
Holding Temperature Not Adequate	Case and food pans have not been preheated.	Refer to the preheating section on page 6. If problem persists, contact an authorized BKI service agent for corrective action.
	One or more heating elements or thermostats not operating properly.	Contact an authorized BKI service agent for corrective action.
	Product is below 160° F when loaded.	Check product temperature before loading the case.
	Loose Wire or bad Connection.	Contact an authorized BKI service agent for corrective action.

Notes



P.O. Box 80400, Simpsonville, S.C. 29680-0400, USA
<http://www.bkideas.com>

Made and printed in the U.S.A
LI0182/0604