



**INSTALLATION INSTRUCTIONS
OPERATING INSTRUCTIONS
WARRANTY POLICY & PROCEDURES**

for

**FABRICATION EQUIPMENT: OVERHEAD WARMERS
FABRICATION EQUIPMENT: HOT & COLD FOOD
WELLS/ACCESSORIES
FABRICATION EQUIPMENT: DRAWER ACCESSORIES
and
FABRICATION EQUIPMENT:
SINKS**

OVERHEAD WARMING EQUIPMENT:

Overhead Warmers
Illuminated Light Boxes

HOT FOOD WELLS:

| | |
|---------------------------------|----------------------------|
| Bottom Mount Wells | Economy Bottom Mount Wells |
| Round Soup Wells | Top Mount Wells |
| 4/3 Hot Food Wells | Insulated Top Mount |
| Fractional Insulated Top Mounts | Insulated Cold Pans |
| Multiple Hot Food Wells | Accessories |

HOT PLATES

DRAWER ASSEMBLIES

Holding Drawers
Heavy Duty Drawer Assemblies
Drawer Assemblies
Drawer Pans, Fronts & Accessories

SINKS

Scullery Sinks & Strainer Pan
Bar Sinks

TABLE OF CONTENTS

| | |
|---|--------------|
| GENERAL INFORMATION AND TROUBLESHOOTING | 3 |
| FABRICATION EQUIPMENT: | |
| OVERHEAD WARMING EQUIPMENT | 4 |
| ILLUMINATION LIGHT BOXES | 4 |
| ACCESSORIES | 5 |
| FABRICATION EQUIPMENT: HOT & COLD FOOD WELLS | 6 |
| Models BM80—Insulated Bottom Mount | 6 |
| Models BM30—Bottom Mount | 7 |
| Models SM50—Round Soup Wells | 8 |
| Models TM90—Top Mount Wells | 9 |
| Models TM43—Top Mount Wells | 10 |
| Models HFW — Top Mount Wells Insulated | 11 |
| Models CFW — Top Mount Wells Insulated Cold Pans | 12 |
| Models HFW — Multiple Hot Food Wells | 13 |
| Models SHFW Small Body Small Bezel Hot Food Wells | 14 |
| Small Body Hot Food Wells | 15 |
| APW EZFILL Hot Food Wells | 16 |
| Models SHFWEZ Slim Line Hot Food Wells | 17 |
| Models TM12L—Top Mount Wells | 18 |
| FABRICATION EQUIPMENT: HOLDING DRAWERS | 19-22 |
| Holding Drawers “HDD” Built-in | 19 |
| Holding Drawers Slim Line “HDDS” Built-in | 20 |
| Holding Drawers “HDD” “HDDS” Counter Top | 21 |
| STANDARD HOLDING DRAWER ASSEMBLIES | 22 |
| FABRICATION EQUIPMENT: SINKS | 23 |
| Scullery Sinks | 23 |
| Bar Sinks | 23 |
| WARRANTY & SERVICE INFORMATION | 24 |

GENERAL INFORMATION

General Installation

1. Always clean equipment thoroughly before first use. (See general cleaning instructions.)
2. Check rating label for your model designation & electrical rating.
3. For best results, use stainless steel countertops.
4. All dimensions in parenthesis in centimeters unless noted.

General Operation Instructions

1. All foodservice equipment should be operated by trained personnel.
2. Do not allow your customers to come in contact with any surface labeled "CAUTION HOT."
3. Where applicable: Never pour cold water into dry heated units.
4. Where applicable, do not cook, warm or hold food directly in liner pans (well pans).
Always use steamtable pans/insets, etc.
5. Never hold food below 150°F (66°C).

Wet set-up and operation procedures (Units with drains)

1. Add hot water 120°-140°F (50°-60°C) to well pan:
 - Four Thirds Size units (12 x 27) use 5-1/2 qts. (1-1/3 gallon) (5-1/2 litre)
 - Full Size units (12 x 20) use: 3.75 qts. (15 cups) (3.5 litre)
 - Two Thirds Size units use 2-1/2 qts. (10 cups) (2.5 litre)
 - Half Size units use: 1-1/2 qts. (6 cups) (1.5 litre)
 - One Third Size, use: 3 cups (0.7 litre)
 - 4 Quart Round use 2 cups (1/2 litre)
 - 7 Quart Round use 3 cups (0.7) litre)
 - 11 Quart Round use 1-1/4 qts. (5 cups) (1.4 litre)
2. Turn thermostat control to "10" setting or if equipped with infinite controls to "7" or "HI".
Preheat for approximately 30 minutes.
3. Place covered inset with preheated product into well.
4. Readjust control after another 30 minutes of operation to the "6" setting depending on the amount and/or thickness of product.
5. Keep inset / steamtable pan(s) covered to maintain ideal serving temperature.
6. Do not let well run dry.

Dry set-up and operation procedures (Units without drains)

1. Turn thermostat control to "10" setting or if equipped with infinite controls to "7" or "HI". Preheat for approximately 30 minutes.
2. Place covered inset with preheated product into well.
3. Readjust control after another 30 minutes of operation to maintain desired temperature.
4. Keep inset / steamtable pan (s) covered to maintain ideal serving temperature.

General Cleaning Instructions

1. NEVER clean any electrical unit by immersing it in water. Turn off before surface cleaning.
2. Always clean equipment thoroughly before first use. Clean unit daily. Except where noted on charts: Use warm, soapy water. Mild Cleansers & PLASTIC scouring pads may be used to remove baked-on food & water scale.
3. Turn off electrical units before cleaning or servicing. All service should be preformed by an APW authorized service agency.

GENERAL TROUBLESHOOTING

Always Ask & Check:

1. Is the unit connected to a live power source?
2. Check the circuit breaker.
3. Is power switch on & pilot light glowing?
4. Check rating label. Are you operating unit on proper voltage?

If the above checks out, and you still have problems, call an APW authorized service agency.

OVERHEAD WARMERS

ALL
MODELS: FD

INSTALLATION INSTRUCTIONS

1. Follow General Installation Instructions on page 3. Provide a safe working clearance around unit.
 2. Flush mounting brackets provided on each end of foodwarmer for chain or shelf mounting. Use four #10 screws or studs with locknuts for shelf mounting. Use #14 jack chain and "S" hooks for chain mounting. NOTE: Brackets are turned inward for shipping purposes. Remove screws and reverse brackets.
 3. Optional stainless steel remote rocker or infinite switch box kits. Installation of the remote box by service personnel requires 1/2" conduit, 1/4" push-on terminals, and no. 14 AWG copper wire suitable for at least 90°C. Mount box to a flat surface with two #10 screws or studs with locknuts.
 4. Optional tubular stands: permanently mount foodwarmers to countertop. Optional portable legs and cord sets are also available.
- Remove flush mounting brackets and attach stands or legs with the screws provided. Installation of the 6ft cord sets by service personnel should utilize the strain relief, grounding stud, and porcelain wire nuts provided.

These models are UL listed

NOTE

TO AVOID BURNING OR CHARRING OF MATERIALS IN THE SURFACE BELOW THE FOODWARMER USE ONLY ABOVE AN ALL-METAL STRUCTURE SUCH AS A TABLE OR COUNTER TOP. MINIMUM CLEARANCE 13". FOR OTHER MATERIALS, INSTALL NOT CLOSER THAN 16 INCHES ABOVE THE SURFACE.

REMOTE SWITCHES ARE RECOMMENDED FOR UNDER SHELF MOUNTING. LONGER SWITCH LIFE WILL RESULT FROM COOLER SWITCH MOUNTING LOCATIONS. (SEE OPTIONS).

OVERHEAD WARMERS DIAGRAM

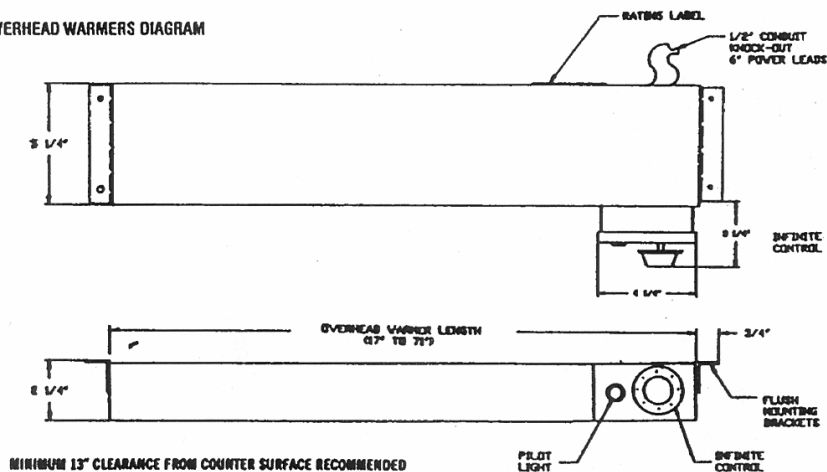

OVERHEAD WARMERS WITH LIGHTS (ADDITIONAL*)

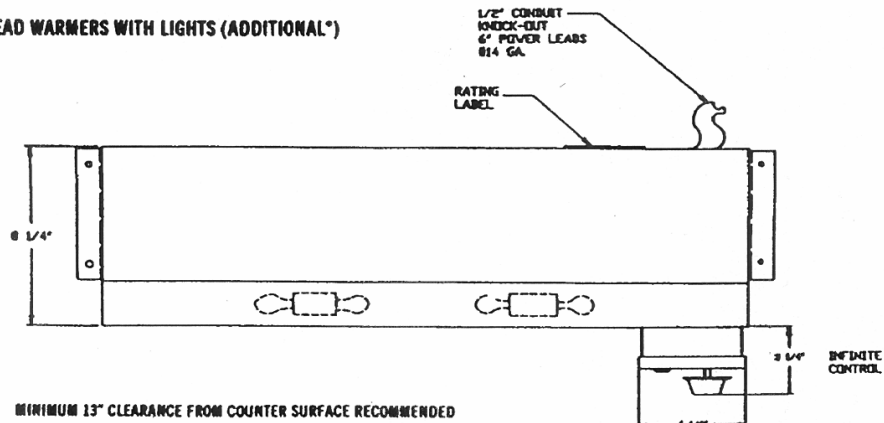

CLOSE-UP OF STANDARD OVERHEAD WARMERS WITH BUILT-ON INFINITE CONTROL

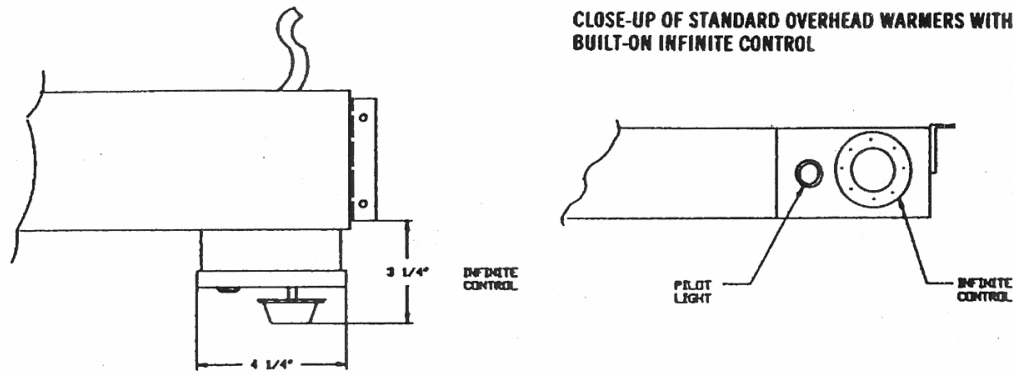

TUBULAR STAND KIT

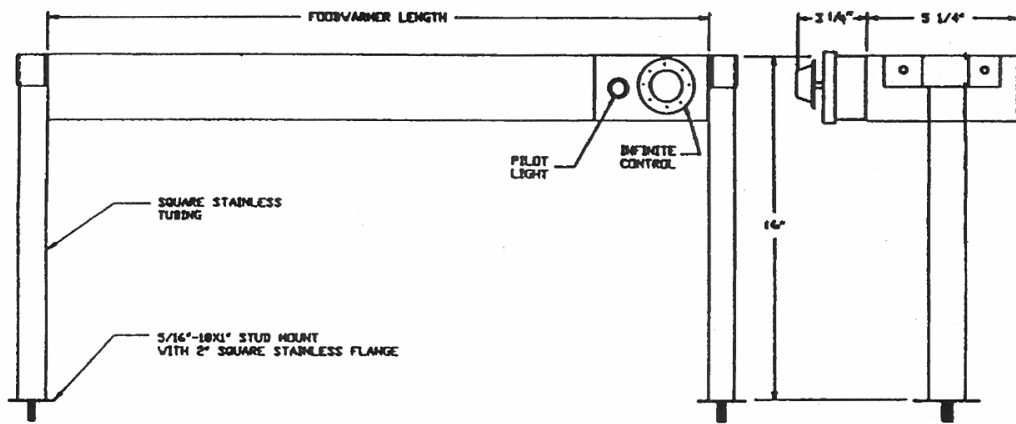

PORTABLE LEG KIT

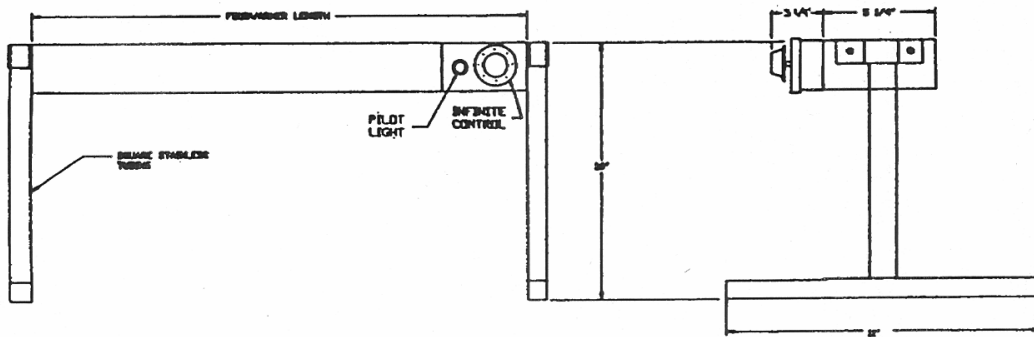

OPERATIONS

1. Follow General Operating Instructions on page 3.
2. Switch on unit. Place precooked product under heat source. Use standard full-size or fractional steamable pans & perforated pan bottoms. Maximum heat coverage equivalent to length of unit.

CLEANING

1. Follow General Cleaning instructions on page 3.

MODELS BM80 BOTTOM MOUNT HOT FOOD WELLS

INSTALLATION

- 1, Follow General Installation Instructions on page 3.
- 2, Install in an all stainless steel counter top.
- 3, Turndown edges of counter top into well pan. Use 1" (2.5) radiused corners.
- 4, Apply 1/4" (.6) bead of silicone sealant to top flange of unit and position warmer underneath counter.
- 5, Secure unit to counter with stainless steel fasteners.
- 6, Mount control as indicated and check nameplate for proper voltage, connect power.

Control Cut Out

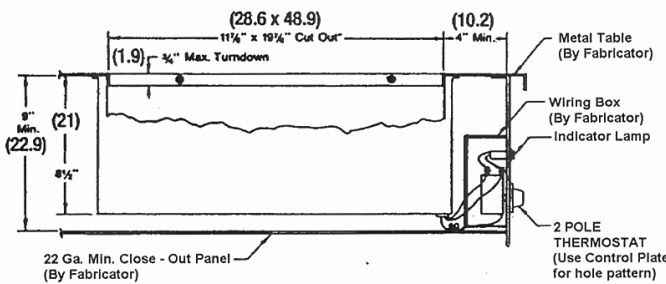
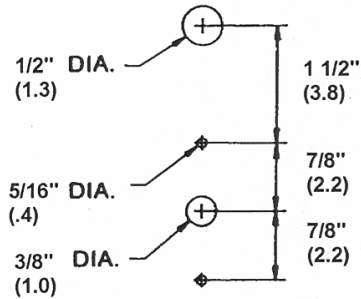

Recessed Bezel Cut Out

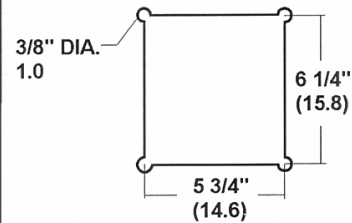

NOTE: UNITS ARE AVAILABLE WITH SQUARE CORNERS OR WITH 1" (2.5 cm) RADIUS CORNERS FOR DIE STAMPED CUT-OUTS

GENERAL SPECIFICATIONS (ALL 80 SERIES)

| Outside Dimensions | Inside Dimensions | Cut Out | Flange | Recommended Flange Turndown | Round Corners Standard | Standard Control | Control Cut Out | Shipping Weight |
|--|--|------------------------------------|-----------------|-----------------------------|------------------------|--|------------------------------------|------------------|
| 13 3/8" x 21 3/4" x 8 5/8" (35.1 x 55.2 x 21.1) | 12 3/8" x 20 1/4" x 6 1/4" (31 x 51.1 x 15.9) | 11 1/4" x 19 1/4" (30.2 x 50.5) | 1 3/8" (2.1) | 3/4" (1.9) | 1" (2.5) Radiused. | Thermostat has 36" (91.4) capillary effective length 26" (66.) | Use Control Plate for hole pattern | 19 lbs. (8.6 kg) |

OPTION SPECIFICATIONS

| Square Corners | Drain Standard w/Model No.'s | Drain Location | Drain Coupling | Thermostat | Recessed Bezel | Electrical Code Kit |
|---|------------------------------|---|-------------------------------------|--|---|-------------------------|
| 3/4" (1.9) Down Add "C" For Sq. Corners | Add "D" For Drain | 1 11/16" X 1 11/16" (4.3) x (4.3) From Back Right Corner. | 1/2 NPT Stainless 1 1/2" (3.8) Long | With 72" (182.9) Capillary Effective Length 62" (157.5) Add (-72) to Model No.'s | Stock No.'s 56370 This is only the Recessed Bezel | Add (UL) to Stock No.'s |

BOTTOM HOUSING
Fully Insulated galvanized steel. Insulated on bottom of Inspection housing.

THERMOSTATS
Equipped with an off-position, using point system and permanent type dial. 250v. 25 AMP, double pole.

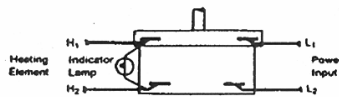

THERMOSTAT

Thermostat is 2 pole and breaks both lines at "OFF" position. Units are prewired to Thermostat. Make line connections as shown. All wiring should be done in accordance with local codes. Use minimum 14 AWG copper wire rated at least 90°C. Optional recessed bezel equipped with 1/2" conduit knockouts.

ELECTRICAL SPECIFICATIONS PER UNIT

| Model No.'s | Volts | Watts | 1PH AMPS |
|-------------|--------------|----------------|-------------------|
| BM-80 | 120v | 750w | 6.25 AMPS |
| | 120v | 1200w | 10 AMPS |
| | 208v | 1000w | 4.81 AMPS |
| | 208v | 1600w | 7.7 AMPS |
| | 208/240v | 1200/1600w | 5.77 / 6.67 AMPS |
| | 208/240/277v | 900/1200/1600w | 4.33/5.0/5.9 AMPS |

OPERATION

1. Follow General Operating Instructions on page 3.

CLEANING

1. Follow General Cleaning instructions on page 3.

MODELS BM30 BOTTOM MOUNT HOT FOOD WELLS

INSTALLATION

1. Follow General Installation Instructions on page 3.
2. Install in an all stainless steel counter top.
3. Turndown edges of counter top into well pan. Use 1" (2.5) radiused corners.
4. Apply 1/4" (.6) bead of silicone sealant to top flange of unit and position warmer underneath counter.
5. Secure unit to counter with stainless steel fasteners.
6. Mount control as indicated and check nameplate for proper voltage, connect power.

Control Cut Out

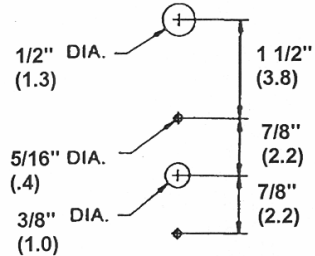

Recessed Bezel Cut Out

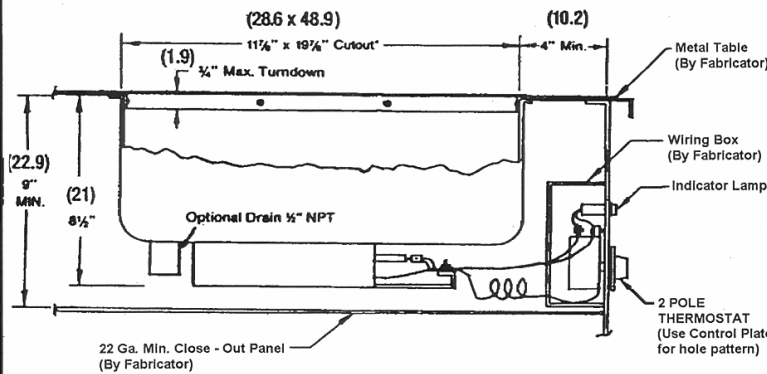
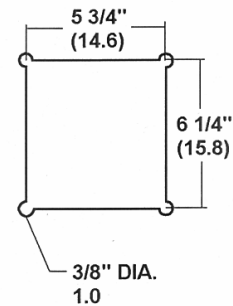

GENERAL SPECIFICATIONS (ALL 30 SERIES)

| Outside Dimensions | Inside Dimensions | Cut Out | Flange | Recommended Flange Turndown | Round Corners Standard | Standard Control | Control Cut Out | Shipping Weight |
|--|--|-----------------------------------|-----------------|-----------------------------|------------------------|--|------------------------------------|---------------------|
| 13 3/8" x 21 1/8" x 8 1/2" (35.1 x 55.2 x 21.1) | 12 3/8" x 20 1/8" x 6 1/4" (31 x 51.1 x 15.9) | 1 1/2" x 1 9/16" (30.2 x 50.5) | 1 3/8" (2.1) | 3/4" (1.9) | 1" (2.5) Radiused. | Thermostat has 36"(91.4) capillary effective length 26"(66.) | Use Control Plate for hole pattern | 18 lbs. (8.2 kg) |

OPTION SPECIFICATIONS

| Thermostat | Drain Standard w/Model No.'s | Drain Location | Drain Coupling | Recessed Bezel | Electrical Code Kit |
|--|------------------------------|---|-------------------------------------|---|-------------------------|
| With 72" (182.9) Capillary Effective Length 62" (157.5) Add (-72) to Model No.'s | BM-30 Add "D" For Drain | 1 11/16" X 1 11/16" (4.3) x (4.3) From Back Right Corner. | 1/2 NPT Stainless 1 1/2" (3.8) Long | Stock No.'s 56370 This is only the Recessed Bezel | Add (UL) to Stock No.'s |

BOTTOM HOUSING
Insulated on bottom of element housing.

THERMOSTATS
Equipped with an off-position, using point system and permanent type dial. 250v. 25 AMP, double pole.

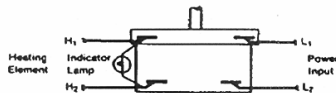

THERMOSTAT

Thermostat is 2 pole and breaks both lines at "OFF" position. Units are prewired to Thermostat. Make line connections as shown. All wiring should be done in accordance with local codes. Use minimum 14 AWG copper wire rated at least 90°C. Optional recessed bezel equipped with 1/2" conduit knockouts.

ELECTRICAL SPECIFICATIONS PER UNIT

| Model No.'s | Volts | Watts | 1PH AMPS |
|-------------|--------------|----------------|-------------------|
| BM-30 | 120v | 750w | 6.25 AMPS |
| | 120v | 1200w | 10 AMPS |
| | 208v | 1600w | 7.7 AMPS |
| | 208/240v | 1200/1600w | 5.77 / 6.67 AMPS |
| | 208/240/277v | 900/1200/1600w | 4.33/5.0/5.9 AMPS |

OPERATION

1. Follow General Operating Instructions on page 3.

CLEANING

1. Follow General Cleaning instructions on page 3.

MODELS SM50 SOUP WELLS TOP MOUNT W/EZ LOCK

INSTALLATION

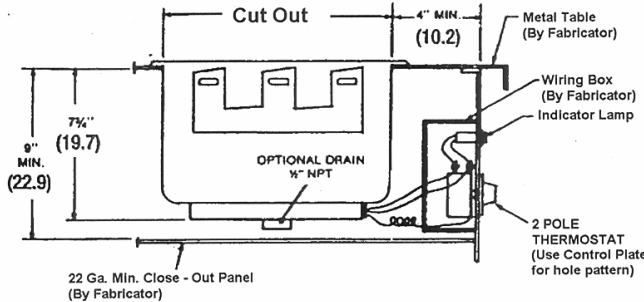

- 1, Follow General Installation Instructions on page 3.
- 2, Make applicable Cut-Out per above table. Note: Unit is designed for installation in stainless steel tops. Optional wood mounting kit available.
- 3, Apply putty tape to underside perimeter of the well rim outer edge.
- 4, Apply a 1/4" (.6) bead of silicone sealant adjacent to the putty tape on the well flange.
- 5, Drop well into opening from the top and push down until entire perimeter of rim is flush with the counter surface.
- 6, From below the counter surface insert an 8# to 10# (20 to 25 cm) flat tip screwdriver into the locking ring tab slots and twist in a clockwise motion to lock well in place.
- 7, Trim excess putty and sealant from around well rim.
- 8, Mount control to front panel using hardware. Maintain 4" (10.2) clearance between well and front panel.
- 9, Check nameplate for proper voltage, Connect power. Note: Electrically connect units to comply with local and NEC codes.

Recessed Bezel Cut Out

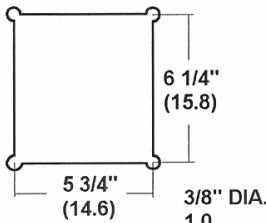

Control Cut Out

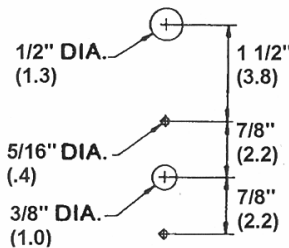

GENERAL SPECIFICATIONS (4 QT., 7 QT. AND 11 QT.)

| Description | Outside Dimensions | Inside Dimensions | Cut Out | Flange | Standard Control | Control Cut Out | Shipping Weight |
|--------------------|--|--|-----------------------------|-------------|--|------------------------------------|-------------------|
| 4 QT. (3.8 L) | 8 25/64" dia. x 8 1/8" dia. (21.2) dia. x (20.6) dia. | 6 25/64" dia. x 6 1/2" dia. (16.2) dia. x (15.5) dia. | 6 3/4" dia. (17.1) dia. | 1" (2.5) | Thermostat has 36" (91.4) capillary effective length 26" (66.) | Use Control Plate for hole Pattern | 9 Lbs. (22.9) |
| 7 QT. (6.6 L) | 10 1/2" dia. x 8 1/8" dia. (26.7) dia. x (20.6) dia. | 8 9/32" dia. x 6 1/2" dia. (21.0) dia. x (15.5) dia. | 8 3/4" dia. (22.2) dia. | 1" (2.5) | Thermostat has 36" (91.4) capillary effective length 26" (66.) | Use Control Plate for hole Pattern | 11 Lbs. (27.9) |
| 11 QT. (10.4 L) | 12 1/2" dia. x 8 1/8" dia. (31.8) dia. x (20.6) dia. | 10 9/32" dia. x 6 1/2" dia. (26.1) dia. x (15.5) dia. | 10 3/4" dia. (27.3) dia. | 1" (2.5) | Thermostat has 36" (91.4) capillary effective length 26" (66.) | Use Control Plate for hole Pattern | 12 Lbs. (30.5) |

OPTION SPECIFICATIONS

| Drain Standard w/Model No.'s | Drain Location | Drain Coupling | Thermostat | Recessed Bezel | Wood Mounting Kit, Stock No.'s | Wood Mounting Kit, Cut Out | Electrical Code Kit |
|---|--|--|--|--|--|---|-------------------------|
| SM-50-4 SM-50-7 SM-50-11 Add "D" For Drain | 1 11/16" X 1 11/16" (4.3) x (4.3) From Back Right Corner. | 1/2 NPT Stainless 1 1/2" (3.8) Long | With 72" (182.9) Capillary Effective Length 82" (157.5) Add (-72) to Model No.'s | Stock No.'s 56370 This is only the Recessed Bezel | 4 QT. 55286 7 QT. 55333 11 QT. 55323 | 8 13/16" x 8 13/16" (22.4 x 22.4) 10 13/16" x 10 13/16" (27.5 x 27.5) 12 13/16" x 12 13/16" (32.5 x 32.5) | Add (UL) to Stock No.'s |

THERMOSTATS
Equipped with an off-position, using point system and permanent type dial. 250v. 25 AMP, double pole.

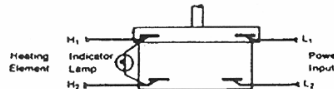

THERMOSTAT

Thermostat is 2 pole and breaks both lines at "OFF" position. Units are prewired to Thermostat. Make line connections as shown. All wiring should be done in accordance with local codes. Use minimum 14 AWG copper wire rated at least 90°C. Optional recessed bezel equipped with 1/2" conduit knockouts.

ELECTRICAL SPECIFICATIONS PER UNIT

| Model No.'s | Volts | Watts | 1PH AMPS |
|-------------|----------|----------|----------------|
| SM-50-4 | 120v | 400w | 3.33 AMPS |
| | 240v | 400w | 1.67 AMPS |
| SM-50-7 | 120v | 500w | 4.17 AMPS |
| | 120v | 800w | 6.67 AMPS |
| SM-50-11 | 208/240v | 500/660w | 2.40/2.75 AMPS |

OPERATION

1. Follow General Operating Instructions on page 3.

CLEANING

1. Follow General Cleaning instructions on page 3.

MODELS TM90 — TOP MOUNT HOT FOOD WELLS W/EZ LOCK

INSTALLATION

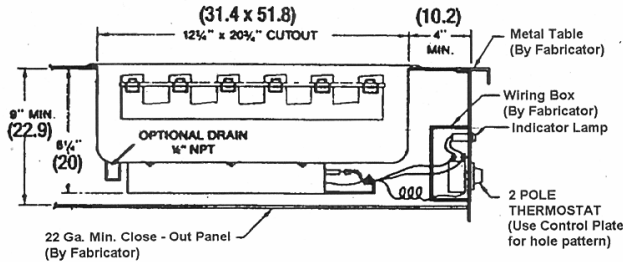

- 1, Follow General Installation Instructions on page 3.
 - 2, Make applicable Cut-Out per above table. Note: Unit is designed for installation in stainless steel tops. Optional wood mounting kit available.
 - 3, Apply putty tape to underside perimeter of the well rim outer edge.
 - 4, Apply a 1/4" (.6) bead of silicone sealant adjacent to the putty tape on the well flange.
 - 5, Drop well into opening from the top and push down until entire perimeter of rim is flush with the counter surface.
 - 6, From below the counter surface insert an 8# to 10# (20 to 25 cm) flat tip screwdriver into the locking ring tab slots and twist in a clockwise motion to lock well in place.
 - 7, Trim excess putty and sealant from around well rim.
 - 8, Mount control to front panel using hardware. Maintain 4" (10.2) clearance between well and front panel.
 - 9, Check nameplate for proper voltage, Connect power.
- Note: Electrically connect units to comply with local and NEC codes.

Recessed Bezel Cut Out

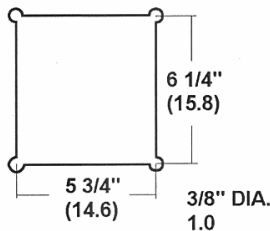

Control Cut Out

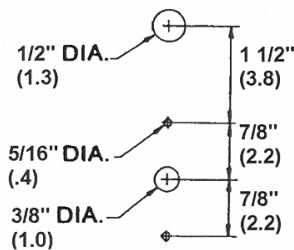

GENERAL SPECIFICATIONS (ALL 90 SERIES)

| Outside Dimensions | Inside Dimensions | Cut Out | Flange | Standard Control | Control Cut Out | Round Corners Standard | Shipping Weight |
|--|--|------------------------------------|---------------|--|------------------------------------|------------------------|---------------------|
| 13 3/8" x 21 3/8" x 8 3/8" (34.6 x 54.9 x 21.1) | 11 1/4" x 19 1/4" x 6 1/4" (30.2 x 50.5 x 15.9) | 12 3/4" x 20 3/4" (31.4 x 51.8) | 7/8" (2.2) | Thermostat has 36" (91.4) capillary effective length 26" (66.) | Use Control Plate for hole pattern | 1" (2.5) Radiused. | 17 lbs. (7.7 kg) |

OPTION SPECIFICATIONS

| Thermostat | Recessed Bezel | Wood Mounting Kit, Stock No.'s | Wood Mounting Kit, Cut Out | Drain Standard w/Model No.'s | Drain Location | Drain Coupling | Electrical Code Kit |
|--|---|--------------------------------|---------------------------------|------------------------------|---|-------------------------------------|-------------------------|
| With 72" (182.9) Capillary Effective Length 62" (157.5) Add (-72) to Model No.'s | Stock No.'s 56370 This is only the Recessed Bezel | 55313 | 14 5/8" x 22 5/8" (37.1 x 57.5) | TM-90 Add "D" For Drain | 1 11/16" X 1 11/16" (4.3) x (4.3) From Back Right Corner. | 1/2 NPT Stainless 1 1/2" (3.8) Long | Add (UL) to Stock No.'s |

BOTTOM HOUSING
Insulated on bottom of element housing.

THERMOSTATS
Equipped with an off-position, using point system and permanent type dial. 250v. 25 AMP, double pole.

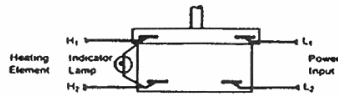

THERMOSTAT

Thermostat is 2 pole and breaks both lines at "OFF" position. Units are prewired to Thermostat. Make line connections as shown. All wiring should be done in accordance with local codes. Use minimum 14 AWG copper wire rated at least 90°C. Optional recessed bezel equipped with 1/2" conduit knockouts.

ELECTRICAL SPECIFICATIONS PER UNIT

| Model No.'s | Volts | Watts | 1PH AMPS |
|-------------|--------------|----------------|-------------------|
| TM-90 | 120v | 750w | 6.25 AMPS |
| | 120v | 1200w | 10 AMPS |
| | 120v | 1500w | 12.5 AMPS |
| | 208v | 1600w | 7.7 AMPS |
| | 240v | 750w | 3.13 AMPS |
| | 208/240v | 1200/1600w | 5.77/6.67 AMPS |
| | 208/240/277v | 900/1200/1600w | 4.33/5.0/5.9 AMPS |

OPERATION

1. Follow General Operating Instructions on page 3.

CLEANING

1. Follow General Cleaning instructions on page 3.

MODELS TM43 — TOP MOUNT HOT FOOD WELLS W/EZ LOCK

INSTALLATION

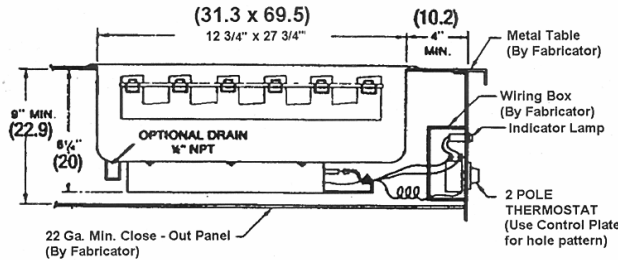

- 1, Follow General Installation Instructions on page 3.
 - 2, Make applicable Cut-Out per above table. Note: Unit is designed for installation in stainless steel tops. Optional wood mounting kit available.
 - 3, Apply putty tape to underside perimeter of the well rim outer edge.
 - 4, Apply a 1/4" (.6) bead of silicone sealant adjacent to the putty tape on the well flange.
 - 5, Drop well into opening from the top and push down until entire perimeter of rim is flush with the counter surface.
 - 6, From below the counter surface insert an 8# to 10# (20 to 25 cm) flat tip screwdriver into the locking ring tab slots and twist in a clockwise motion to lock well in place.
 - 7, Trim excess putty and sealant from around well rim.
 - 8, Mount control to front panel using hardware. Maintain 4" (10.2) clearance between well and front panel.
 - 9, Check nameplate for proper voltage, Connect power.
- Note: Electrically connect units to comply with local and NEC codes.

Recessed Bezel Cut Out

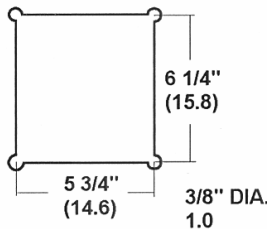

Control Cut Out

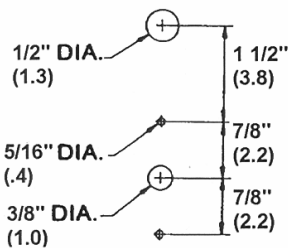

GENERAL SPECIFICATIONS (ALL 4/3 SERIES)

| Outside Dimensions | Inside Dimensions | Cut Out | Flange | Standard Control | Control Cut Out | Round Corners Standard | Shipping Weight |
|--|--|------------------------------------|------------------|--|------------------------------------|------------------------|-------------------|
| 13 5/8" x 28 9/16" x 8 5/16" (34.6 x 72.5 x 21.1) | 11 7/8" x 26 7/8" x 8 1/4" (34.6 x 68.3 x 16.5) | 12 3/4" x 27 3/4" (31.3 x 69.5) | 1 7/16" (3.6) | Thermostat has 36"(91.4) capillary effective length 26"(66.) | Use Control Plate for hole pattern | 1 3/4" (4.4) Radiused | 23 Lbs. (10.4 Kg) |

OPTION SPECIFICATIONS

| Thermostat | Recessed Bezel | Wood Mounting Kit, Stock No.'s | Wood Mounting Kit, Cut Out | Drain Standard w/Model No.'s | Drain Location | Drain Coupling | Electrical Code Kit |
|--|---|--------------------------------|-----------------------------------|------------------------------|---|-------------------------------------|-------------------------|
| With 72" (182.9) Capillary Effective Length 62" (157.5) Add (-72) to Model No.'s | Stock No.'s 56370 This is only the Recessed Bezel | 55317 | 14 11/16" x 29 5/8" (37.3 x 75.2) | TM-43 Add "D" for Drain | 1 11/16" X 1 11/16" (4.3) x (4.3) From Back Right Corner. | 1/2 NPT Stainless 1 1/2" (3.8) Long | Add (UL) to Stock No.'s |

BOTTOM HOUSING
Insulated on bottom of element housing.

THERMOSTATS
Equipped with an off-position, using point system and permanent type dial. 250v. 25 AMP, double pole.

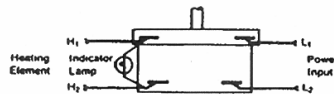

THERMOSTAT

Thermostat is 2 pole and breaks both lines at "OFF" position. Units are prewired to Thermostat. Make line connections as shown. All wiring should be done in accordance with local codes. Use minimum 14 AWG copper wire rated at least 90°C. Optional recessed bezel equipped with 1/2" conduit knockouts.

ELECTRICAL SPECIFICATIONS PER UNIT

| Model No.'s | Volts | Watts | 1PH AMPS |
|-------------|----------|------------|--------------|
| TM-43 | 120v | 1800w | 15 AMPS |
| | 208v | 1800w | 8.66 AMPS |
| | 208/240v | 1200/1600w | 5.8/7.7 AMPS |

OPERATION

1. Follow General Operating Instructions on page 3.

CLEANING

1. Follow General Cleaning instructions on page 3.

MODELS INSULATED – TOP MOUNT HOT FOOD WELLS W/EZ LOCK

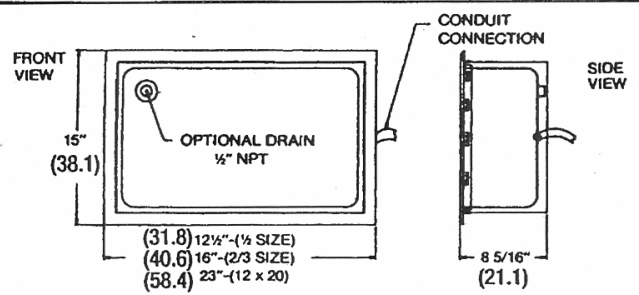

INSTALLATION

- 1, Follow General Installation Instructions on page 3.
 - 2, Make applicable Cut-Out per above table. Note: Unit is designed for installation in stainless steel tops. Optional wood mounting kit available.
 - 3, Apply putty tape to underside perimeter of the well rim outer edge.
 - 4, Apply a 1/4" (.6) bead of silicone sealant adjacent to the putty tape on the well flange.
 - 5, Drop well into opening from the top and push down until entire perimeter of rim is flush with the counter surface.
 - 6, From below the counter surface insert an 8# to 10# (20 to 25 cm) flat tip screwdriver into the locking ring tab slots and twist in a clockwise motion to lock well in place.
 - 7, Trim excess putty and sealant from around well rim.
 - 8, Mount control to front panel using hardware. Maintain 4" (10.2) clearance between well and front panel.
 - 9, Check nameplate for proper voltage, Connect power.
- Note: Electrically connect units to comply with local and NEC codes.

Recessed Bezel Cut Out

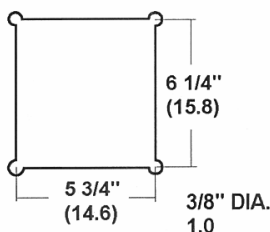

Control Cut Out

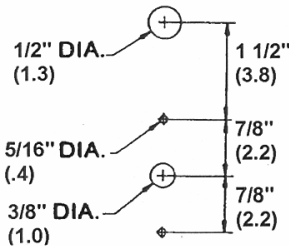

GENERAL SPECIFICATIONS (Full, 2/3 and 1/2 Size)

| Description | Outside Dimensions | Inside Dimensions | Cut Out | Flange | Standard Control | Control Cut Out | Shipping Weight |
|-------------|---|--|------------------------------------|------------------------------|---|---------------------------------------|-------------------|
| Full Size | 23" x 15" x 8 5/16" (58.4 x 38.1 x 21.1) | 19 1/2" x 11 7/8" x 6 1/4" (49.5 x 30.2 x 15.9) | 21 3/4" x 13 3/4" (55.2 x 34.9) | 1 9/16" (3.9) All 4 sides | Thermostat has 36" (91.4) capillary effective length 26" (66.) | Use Control Plate for hole Pattern | 24 Lbs. (10.9 Kg) |
| 2/3 Size | 16" x 15" x 8 5/16" (40.6 x 38.1 x 21.1) | 13" x 11 7/8" x 6 1/4" (33.0 x 30.2 x 15.9) | 14 5/8" x 13 3/4" (37.1 x 34.9) | | | | 20 Lbs. (9.1 Kg) |
| 1/2 Size | 12 1/2" x 15" x 8 5/16" (31.8 x 38.1 x 21.1) | 9 1/2" x 11 7/8" x 6 1/4" (24.1 x 30.2 x 15.9) | 11 1/2" x 13 3/4" (29.2 x 34.9) | | | | 18 Lbs. (8.2 Kg) |

OPTION SPECIFICATIONS

| Drain Standard w/Model No.'s | Drain Location | Drain Coupling | Thermostat | Recessed Bezel | Wood Mounting Kit, Stock No.'s | Wood Mounting Kit, Cut Out | Electrical Code Kit |
|--|---|--|--|--|---|---|----------------------------|
| HFV-1 HFV-23 HFV-12 Add "D" For Drain | 1 11/16" X 1 11/16" (4.3) x (4.3) From Back Right Corner. | 1/2 NPT Stainless 1 1/2" (3.8) Long | With 72" (182.9) Capillary Effective Length 62" (157.5) Add (-72) to Model No.'s | Stock No.'s 56370 This is only the Recessed Bezel | HFV-1 56431 HFV-23 56460 HFV-12 56413 | 21 3/4" x 15 3/4" (55.2 x 40.0) 16 5/8" x 15 3/4" (42.2 x 40.0) 13 1/2" x 15 3/4" (34.3 x 40.0) | Add (UL) to Stock No.'s |

THERMOSTATS
Equipped with an off-position, using point system and permanent type dial. 250v. 25 AMP, double pole.

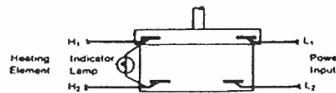

THERMOSTAT

Thermostat is 2 pole and breaks both lines at "OFF" position. Units are prewired to Thermostat. Make line connections as shown. All wiring should be done in accordance with local codes. Use minimum 14 AWG copper wire rated at least 90°C. Optional recessed bezel equipped with 1/2" conduit knockouts.

ELECTRICAL SPECIFICATIONS PER UNIT

| Model No.'s | Volts | Watts | 1PH AMPS |
|-------------|----------|------------|----------------|
| HFV-1 | 120v | 750w | 6.25 AMPS |
| | 120v | 1500w | 12.5 AMPS |
| | 208v | 1600w | 7.7 AMPS |
| | 208/240v | 1200/1600w | 5.8/7.7 AMPS |
| HFV-23 | 120v | 800w | 6.67 AMPS |
| HFV-12 | 120v | 500w | 4.2 AMPS |
| | 120v | 800w | 6.67 AMPS |
| | 208/240v | 500/660w | 2.40/2.75 AMPS |

OPERATION

1. Follow General Operating Instructions on page 3.

CLEANING

1. Follow General Cleaning instructions on page 3.

MODELS INSULATED-TOP MOUNT COLD FOOD WELLS W/EZ LOCK

INSTALLATION

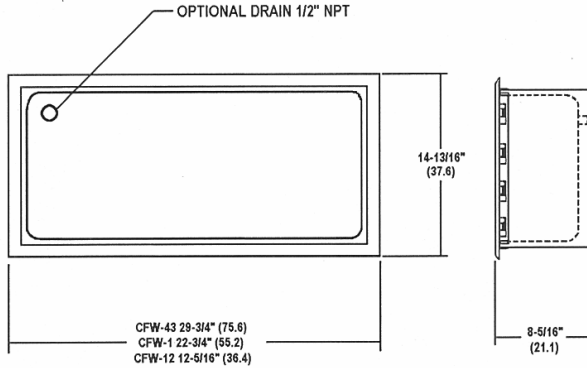

- 1, Follow General Installation Instructions on page 3.
- 2, Make applicable Cut-Out per above table.
Note: Unit is designed for installation in stainless steel tops. Optional wood mounting kit available.
- 3, Apply putty tape to underside perimeter of the well rim outer edge.
- 4, Apply a 1/4" (.6) bead of silicone sealant adjacent to the putty tape on the well flange.
- 5, Drop well into opening from the top and push down until entire perimeter of rim is flush with the counter surface.
- 6, From below the counter surface insert an 8# to 10# (20 to 25 cm) flat tip screwdriver into the locking ring tab slots and twist in a clockwise motion to lock well in place.
- 7, Trim excess putty and sealant from around well rim.

GENERAL SPECIFICATIONS (4/3, Full and 1/2 Size)

| Description | Outside Dimensions | Inside Dimensions | Cut Out | Flange | Shipping Weight |
|-------------|--|--|------------------------------------|-------------------------------------|-------------------|
| 4/3 SIZE | 14-13/16" X 29-3/4" X 8-5/16" (37.6 X 75.6 X 21.1) | 11-7/8" X 26-7/8" X 6-1/4" (30.2 X 68.3 X 15.9) | 13-3/4" X 28-5/8" (34.9 X 72.7) | 1-7/16" (3.6) 9 Lbs. All 4 sides | 29 Lbs. (13.2 Kg) |
| FULL SIZE | 14-13/16" X 22-3/4" X 8-5/16" (37.6 X 57.8 X 21.1) | 11-7/8" X 19-7/8" X 6-1/4" (30.2 X 50.5 X 15.9) | 13-3/4" X 21-3/4" (34.9 X 55.2) | | 24 Lbs. (10.9 Kg) |
| 1/2 SIZE | 14-13/16" X 12-5/16" X 8-5/16" (37.6 X 36.4 X 21.1) | 11-7/8" X 9-7/8" X 6-1/4" (30.2 X 25.1 X 15.9) | 13-3/4" X 11-1/2" (29.2 X 34.9) | | 18 Lbs. (8.2 Kg) |

OPTIONS SPECIFICATIONS

| Drain Standard w/Model No.'s | Drain Location | Drain Coupling | Drain kit, Stock No.'s | Wood Mounting Kit, Stock No.'s | Wood Mounting Kit, Cut Out |
|--|---|--|---|-----------------------------------|--|
| CFW-43 CFW-1 CFW-12 Add "D" For Drain | 1 11/16" X 1 11/16" (4.3) X (4.3) From Back Right Corner. | 1/2 NPT Stainless 1 1/2" (3.8) Long | Drain kit for all wells include 1/2" (1.3) PVC & 3 Ft. (91.4) of high Temp. Flexible hose. Stock No. 56420 | FULL SIZE 56431 1/2 SIZE 56413 | 21-3/4" X 15-3/4" (55.2 X 40.0) 13-1/2" X 15-3/4" (34.3 X 40.0) |

OPERATION

1. The well pan should be filled with enough ice to touch the bottom of the insert pan(s).
2. When used, insert pans less than 6 inches (15.2) are recommended.
3. Replenish ice as required.

CLEANING

1. After installation, prior to use, clean equipment. Clean unit after use using warm, soapy water.
2. Mild cleansers & plastic scouring pads may be used to remove water scale.
3. Rinse thoroughly.

MULTIPLE HOT FOOD WELLS

ALL MODELS: HFW

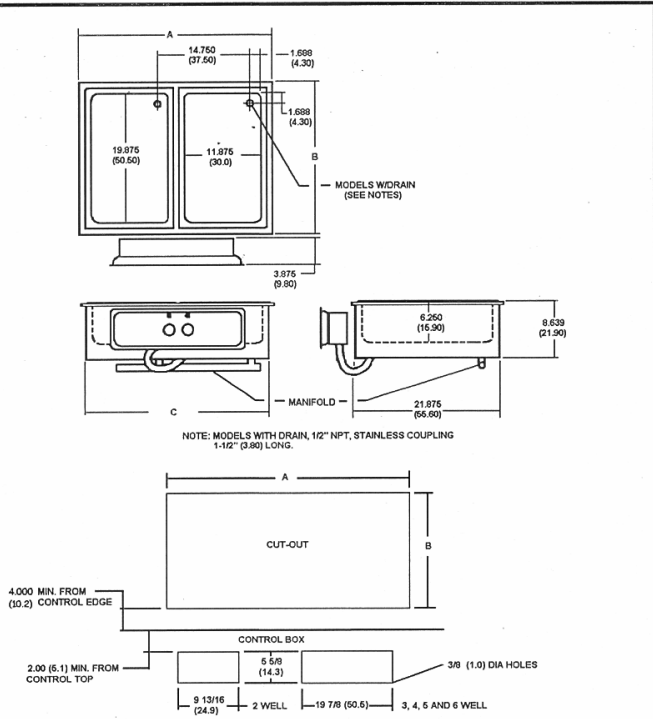

INSTALLATION

- 1, Follow General Installation Instructions on page 3.
 - 2, Make applicable Cut-Out per above table. Note: Unit is designed for installation in stainless steel tops. Optional wood mounting kit available.
 - 3, Apply putty tape to underside perimeter of the well rim outer edge.
 - 4, Apply a 1/4" (.6) bead of silicone sealant adjacent to the putty tape on the well flange.
 - 5, Drop well into opening from the top and push down until entire perimeter of rim is flush with the counter surface.
 - 6, From below the counter surface insert an 8# to 10# (20 to 25 cm) flat tip screwdriver into the locking ring tab slots and twist in a clockwise motion to lock well in place.
 - 7, Trim excess putty and sealant from around well rim.
 - 8, Mount control to front panel using hardware. Maintain 4" (10.2) clearance between well and front panel.
 - 9, Check nameplate for proper voltage, Connect power.
- Note: Electrically connect units to comply with local and NEC codes.

GENERAL SPECIFICATIONS (MULTIPLE HOT FOOD WELLS)

| Model | Outside Dimensions | | | Cut Out | | Control Cut Out | Shipping Weight |
|------------|--------------------|-------------------|--------------------|--------------------|-------------------|-----------------|---------------------|
| | A | B | C | A | B | | |
| HFW-2 WELL | 29.750" (75.6) | 23.438" (59.5) | 28.122" (71.4) | 28.622" (72.7) | 22.500" (57.2) | SEE ABOVE | 48 LBS. (21.8KG) |
| HFW-3 WELL | 44.125" (112.1) | 23.438" (59.5) | 42.497" (107.9) | 42.997" (109.2) | 22.500" (57.2) | SEE ABOVE | 68 LBS. (30.8KG) |
| HFW-4 WELL | 58.500" (148.6) | 23.438" (59.5) | 56.872" (144.4) | 57.372" (145.7) | 22.500" (57.2) | SEE ABOVE | 98 LBS. (44.4 KG) |
| HFW-5 WELL | 72.875" (185.1) | 23.438" (59.5) | 71.247" (181.0) | 71.747" (182.2) | 22.500" (57.2) | SEE ABOVE | 118 LBS. (53.5 KG) |
| HFW-6 WELL | 87.250" (221.6) | 23.438" (59.5) | 85.622" (217.5) | 86.122" (218.7) | 22.500" (57.2) | SEE ABOVE | 260 LBS. (117.9 KG) |

ELECTRICAL SPECIFICATIONS

| Model | Electrical Ratings | | | | Electrical Ratings | | | |
|------------|--------------------|----------------------------------|-------------|------------------|--------------------|----------------|------|------------------|
| | Volts | Watts | Amps | Max Amps 3-Phase | Volts | Watts | Amps | Max Amps 3-Phase |
| HFW-2 WELL | 208 / 240 | 2400 / 3200 | 11.5 / 13.3 | 6.7 / 7.7 | 208 | 3200 | 15.4 | 8.9 |
| HFW-3 WELL | 208 / 240 | 3600 / 4800 | 17.3 / 20.0 | 10.0 / 11.6 | 208 | 4800 | 23.1 | 13.4 |
| HFW-4 WELL | 208 / 240 | 4800 / 6400 | 23.1 / 26.7 | 13.3 / 15.4 | 208 | 6400 | 30.8 | 17.8 |
| HFW-5 WELL | 208 / 240 | 6000 / 8000 | 28.8 / 33.3 | 16.7 / 19.2 | 208 | 8000 | 38.5 | 22.3 |
| HFW-6 WELL | 208 / 240 | 7200 / 9600 | 34.6 / 40.0 | 20.0 / 23.2 | 208 | 9600 | 46.2 | 26.7 |
| | | 1200 EA. @ 208 1600 EA. @ 240 | | | | 1600 EA. @ 208 | | |

OPERATION

1. Follow General Operating Instructions on page 3.

CLEANING

1. Follow General Cleaning instructions on page 3.

APW SMALL BODY SMALL BEZEL HOT FOOD WELLS

PART NO'S BEGINNING WITH WHFW

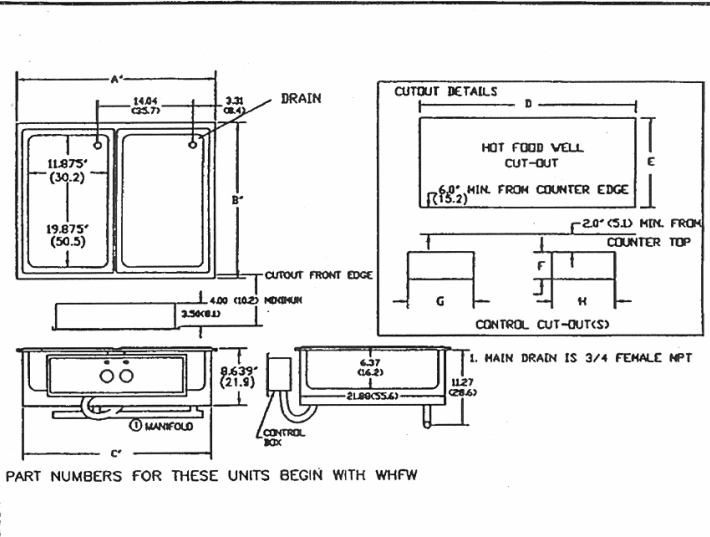

INSTALLATION

1. Follow General Installation Instructions on page 3.
2. These models are designed to be installed in a stainless steel or wood counter.
3. Make applicable cut out in counter top and front panel based on the model to be installed (See Table).
4. Apply putty tape (Provided) to the underside perimeter of the well rim outer edge.
5. Apply a 1/4" (.6cm) bead of silicone sealant adjacent to the putty tape on the well flange.
6. Drop well into opening from the top and push down until entire parameter of rim is flush with the counter surface.
7. From below the counter surface insert an 8" to 10" (20 to 25cm) flat tip screwdriver into the locking ring tab slots and twist in a clockwise motion to lock well in place.
8. trim excess putty and sealant from around well rim.
9. Mount control panel to front panel using hardware. Connect power. Check nameplate for proper voltage. **NOTE: Electrically connect unit in compliance with any local and NEC codes.**

GENERAL SPECIFICATIONS (SMALL BODY HOT FOOD WELLS)

| Model | Outside Dimensions | | | Cut Out | | Control Cut Out | | | Ship Wt. |
|--------------|--------------------|------------------|-------------------|-------------------|-----------------|-----------------|-----------------|-----------------|---------------------|
| | A | B | C | D | E | F | G | H | |
| SHFW-2D WELL | 29.42" (74.2) | 23.44" (59.5) | 27.79" (70.6) | 28.50" (72.4) | 22.5" (57.2) | 5.0" (12.7) | 12.5" (31.8) | n/a | 48 Lbs. (21.8 Kg) |
| SHFW-3D WELL | 43.46" (110.4) | 23.44" (59.5) | 41.83" (106.2) | 42.50" (108.0) | 22.5" (57.2) | 5.0" (12.7) | 16.5" (41.9) | n/a | 68 Lbs. (30.8 Kg) |
| SHFW-4D WELL | 57.50" (146.0) | 23.44" (59.5) | 55.87" (141.9) | 56.50" (143.5) | 22.5" (57.2) | 5.0" (12.7) | 16.5" (41.9) | n/a | 98 Lbs. (44.4 Kg) |
| SHFW-5D WELL | 71.54" (181.7) | 23.44" (59.5) | 69.92" (177.6) | 70.50" (179.1) | 22.5" (57.2) | 5.0" (12.7) | 16.5" (41.9) | n/a | 118 Lbs. (53.5 Kg) |
| SHFW-6D WELL | 85.59" (217.4) | 23.44" (59.5) | 83.96" (213.2) | 84.50" (214.6) | 22.5" (57.2) | 5.0" (12.7) | 16.5" (41.9) | 16.5" (41.9) | 260 Lbs. (117.9 Kg) |

OPTIONS

Description: Lever Operated Drain Valve

Stock No.: 56360

Drain Manifold: Fabricated to Unit, Specify

ELECTRICAL SPECIFICATIONS

| Model | Electrical Ratings | | | | Electrical Ratings | | | |
|--------|--------------------|-------------|--------------|------------------|--------------------|-------|--------------|------------------|
| | Volts | Watts | Amps 1-Phase | Max Amps 3-Phase | Volts | Watts | Amps 1-Phase | Max Amps 3-Phase |
| 2 WELL | 208 / 240 | 2400 / 3200 | 12 / 14 | 10 / 12 | 208 | 3200 | 16 | 14 |
| 3 WELL | 208 / 240 | 3600 / 4800 | 18 / 20 | 10 / 12 | 208 | 4800 | 23 | 14 |
| 4 WELL | 208 / 240 | 4800 / 6400 | 24 / 27 | 16 / 18 | 208 | 6400 | 31 | 21 |
| 5 WELL | 208 / 240 | 6000 / 8000 | 29 / 34 | 20 / 24 | 208 | 8000 | 39 | 27 |
| 6 WELL | 208 / 240 | 7200 / 9600 | 35 / 40 | 20 / 24 | 208 | 9600 | 47 | 27 |

NOTE: CUT-OUT SIZES ARE DIFFERENT FROM STANDARD APW HFWS

OPERATION

1. Follow General Operating Instructions on page 3.

CLEANING

1. Follow General Cleaning instructions on page 3.

SMALL BODY HOT FOOD WELLS

PART NO.'S FOR THESE UNITS BEGIN WITH SHFW

COUPLING 1/2" NPT STAINLESS
1 1/2" (3.8) LONG

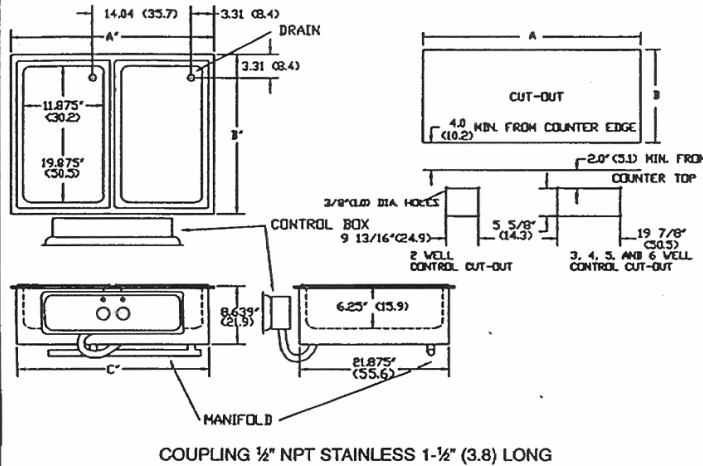

INSTALLATION

1. Follow General Installation Instructions on page 3.
2. These models are designed to be installed in a stainless steel or wood counter.
3. Make applicable cut out in counter top and front panel based on the model to be installed (See Table).
4. Apply putty tape (Provided) to the underside perimeter of the well rim outer edge.
5. Apply a 1/4" (.6cm) bead of silicone sealant adjacent to the putty tape on the well flange.
6. Drop well into opening from the top and push down until entire parameter of rim is flush with the counter surface.
7. From below the counter surface insert an 8" to 10" (20 to 25cm) flat tip screwdriver into the locking ring tab slots and twist in a clockwise motion to lock well in place.
8. trim excess putty and sealant from around well rim.
9. Mount control panel to front panel using hardware. Connect power. Check nameplate for proper voltage. **NOTE: Electrically connect unit in compliance with any local and NEC codes.**

GENERAL SPECIFICATIONS (SMALL BODY HOT FOOD WELLS)

| Model | Outside Dimensions | | | Cut Out | | Control Cut Out | Ship Wt. |
|--------|--------------------|-------------------|--------------------|------------------|-----------------|-----------------|--------------------|
| | A | B | C | A | B | | |
| SHFW-2 | 29.417" (74.7) | 23.438" (59.5) | 27.789" (70.6) | 28.5" (72.4) | 22.5" (57.2) | See Above | 48 Lbs. (21.8 Kg) |
| SHFW-3 | 43.459" (110.4) | 23.438" (59.5) | 41.831" (106.2) | 42.5" (108.0) | 22.5" (57.2) | See Above | 68 Lbs. (30.8 Kg) |
| SHFW-4 | 57.501" (146.0) | 23.438" (59.5) | 55.873" (141.9) | 56.5" (143.5) | 22.5" (57.2) | See Above | 98 Lbs. (44.4 Kg) |
| SHFW-5 | 71.543" (181.7) | 23.438" (59.5) | 69.915" (177.6) | 70.5" (179.1) | 22.5" (57.2) | See Above | 118 Lbs. (53.5 Kg) |

OPTIONS

Description: Lever Operated Drain Valve

Stock No.: 56360

Drain Manifold: Fabricated to Unit, Specify

ELECTRICAL SPECIFICATIONS

| Model | Electrical Ratings | | | Electrical Ratings | | |
|--------|--------------------|------------------------------|-------------|--------------------|--------------|------|
| | Volts | Watts | Amps | Volts | Watts | Amps |
| SHFW-2 | 208 / 240 | 2400 / 3200 | 11.5 / 13.3 | 208 | 3200 | 15.4 |
| SHFW-3 | 208 / 240 | 3600 / 4800 | 17.3 / 20 | 208 | 4800 | 23 |
| SHFW-4 | 208 / 240 | 4800 / 6400 | 23.1 / 26.7 | 208 | 6400 | 30.8 |
| SHFW-5 | 208 / 240 | 6000 / 8000 | 28.8 / 33.3 | 208 | 8000 | 38.5 |
| | | 1200 EA.@208 1600 EA.@240 | | | 1600 EA.@208 | |

NOTE: CUT-OUT SIZES ARE DIFFERENT FROM STANDARD APW HFWS

OPERATION

1. Follow General Operating Instructions on page 3.

CLEANING

1. Follow General Cleaning instructions on page 3.

APW EZFILL HOT FOOD WELLS

PART NO'S BEGINNING WITH WHFW

INSTALLATION

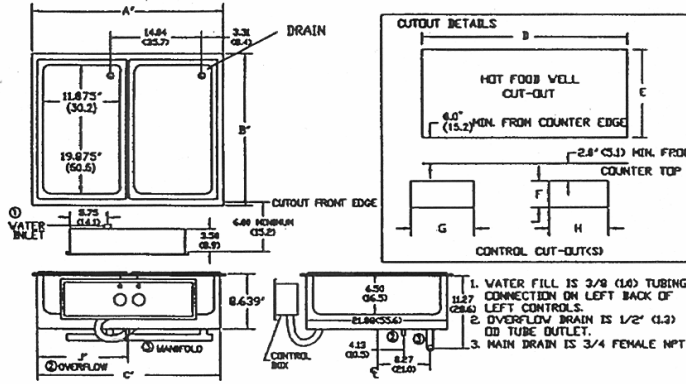

1. Follow General Installation Instructions on page 3.
 2. Make applicable Cut-Out per above table. Note: Unit is designed for installation in stainless steel tops. Optional wood mounting kit available.
 3. Apply putty tape to the underside perimeter of the well rim outer edge.
 4. Apply a 1/4" (.6) bead of silicone sealant adjacent to the putty tape on the well flange.
 5. Drop well into opening from the top and push down until entire perimeter of rim is flush with the counter surface.
 6. From below the counter surface insert an 8" to 10" (20 to 25cm) flat tip screwdriver into the locking ring tab slots and twist in a clockwise motion to lock well in place.
 7. Trim excess putty and sealant from around well rim.
 8. Mount control to front panel using hardware. Maintain 4" (10.2) clearance between well and front panel.
 9. Check nameplate for proper voltage, Connect power.
 10. Connect overflow tube on hot food well to suitable tubing to handle 212 F water run to open drain.
- Note: Electrically connect units to comply with local and NEC codes.

GENERAL SPECIFICATIONS (APW EZFILL HOT FOOD WELLS)

| Model | Outside Dimensions | | | | Cut Out | | Control Cut Out | | | Ship Wt. |
|----------------|--------------------|------------------|-------------------|-------------------|-------------------|-----------------|-----------------|------------------|--------|---------------------|
| | A | B | C | J OVERFLOW | D | E | F | G | H | |
| SHFWEZ-2D WELL | 29.42" (74.2) | 23.44" (59.5) | 27.79" (70.6) | 13.87" (35.2) | 28.5" (72.4) | 22.5" (57.2) | 5.0" (12.7) | 16.50" (41.9) | n/a | 48 Lbs. (21.8 Kg) |
| SHFWEZ-3D WELL | 43.46" (110.4) | 23.44" (59.5) | 41.83" (106.2) | 27.92" (70.9) | 42.5" (108.0) | 22.5" (57.2) | 5.0" (12.7) | 33.50" (85.1) | n/a | 68 Lbs. (30.8 Kg) |
| SHFWEZ-4D WELL | 57.50" (146.0) | 23.44" (59.5) | 55.87" (141.9) | 27.92" (70.9) | 56.5" (143.5) | 22.5" (57.2) | 5.0" (12.7) | 16.50" (41.9) | 12.50" | 98 Lbs. (44.4 Kg) |
| SHFWEZ-5D WELL | 71.54" (181.7) | 23.44" (59.5) | 69.92" (177.6) | 41.96" (106.6) | 70.5" (179.1) | 22.5" (57.2) | 5.0" (12.7) | 33.50" (85.1) | n/a | 118 Lbs. (53.5 Kg) |
| SHFWEZ-6D WELL | 85.59" (217.4) | 23.44" (59.5) | 83.96" (213.2) | 41.96" (106.6) | 84.50" (214.6) | 22.5" (57.2) | 5.0" (12.7) | 33.50" (85.1) | n/a | 260 Lbs. (117.9 Kg) |

OPTIONS

Description: Lever Operated Drain Valve Stock No.: 56360 Drain Manifold: Fabricated to Unit, Required

ELECTRICAL SPECIFICATIONS

| Model | Electrical Ratings 1200 EA. @ 208V / 1600 EA. @ 240V | | | | Electrical Ratings 1600 EA. @ 208V | | | |
|-----------|--|-------------|--------------|------------------|------------------------------------|-------|--------------|--------------|
| | Volts | Watts | Amps 1-Phase | Max Amps 3-Phase | Volts | Watts | Amps 1-Phase | Amps 3-Phase |
| SHFWEZ-2D | 208 / 240 | 2400 / 3200 | 12 / 14 | 10 / 12 | 208 | 3200 | 16 | 14 |
| SHFWEZ-3D | 208 / 240 | 3600 / 4800 | 18 / 20 | 10 / 12 | 208 | 4800 | 23 | 14 |
| SHFWEZ-4D | 208 / 240 | 4800 / 6400 | 24 / 27 | 16 / 18 | 208 | 6400 | 31 | 21 |
| SHFWEZ-5D | 208 / 240 | 6000 / 8000 | 29 / 34 | 20 / 24 | 208 | 8000 | 39 | 27 |
| SHFWEZ-6D | 208 / 240 | 7200 / 9600 | 35 / 40 | 20 / 24 | 208 | 9600 | 47 | 27 |

NOTE: CUT-OUT SIZES ARE DIFFERENT FROM STANDARD APW HFW'S

OPERATION

CLEANING

1. Follow General Operating Instructions on page 3.

1. Follow General Cleaning instructions on page 3.

APW EZFILL SLIM LINE HOT FOOD WELLS

INSTALLATION

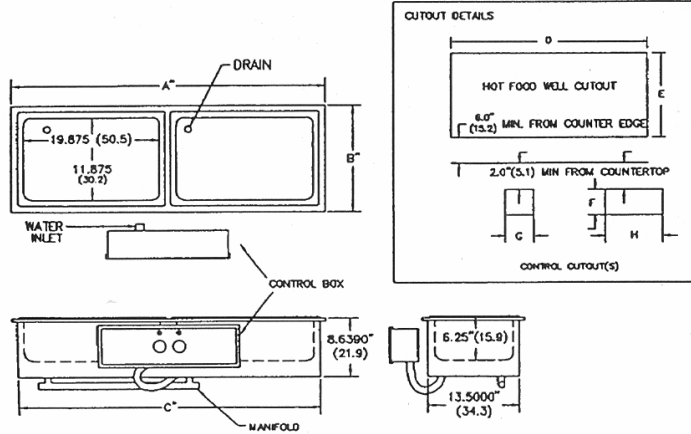

1. WATER FILL IS 1/4\" (4) TUBING CONNECTION ON LEFT BACK OF LEFT CONTROLS.
2. OVERFLOW DRAIN IS 1/2\" (1.27) OD TUBE OUTLET.
3. MAIN DRAIN IS 3/4\" FEMALE NPT.

1. Follow General Installation Instructions on page 3.
 2. Make applicable Cut-Out per above table.
Note: Unit is designed for installation in stainless steel tops. Optional wood mounting kit available.
 3. Apply putty tape to the underside perimeter of the well rim outer edge.
 4. Apply a 1/4\" (6) bead of silicone sealant adjacent to the putty tape on the well flange.
 5. Drop well into opening from the top and push down until entire parameter of rim is flush with the counter surface.
 6. From below the counter surface insert an 8\" to 10\" (20 to 25cm) flat tip screwdriver into the locking ring tab slots and twist in a clockwise motion to lock well in place.
 7. Trim excess putty and sealant from around well rim.
 8. Mount control to front panel using hardware. Maintain 4\" (10.2) clearance between well and front panel.
 9. Check nameplate for proper voltage, Connect power.
 10. Connect overflow tube on hot food well to suitable tubing to handle 212 F water run to open drain.
- Note: Electrically connect units to comply with local and NEC codes.**

GENERAL SPECIFICATIONS (APW EZFILL SLIM LINE HOT FOOD WELLS)

| Model | Outside Dimensions | | | Cut Out | | Control Cut Out | | | Ship Wt. |
|-----------|---------------------|--------------------|---------------------|-------------------|--------------------|-----------------|-------------------|-------------------|-------------------|
| | A | B | C | D | E | F | G | H | |
| SHFWEZ-2D | 45.409\" (115.3) | 15.055\" (38.2) | 43.781\" (111.2) | 44.5\" (113.0) | 14.125\" (35.9) | 5.0\" (12.7) | 16.50\" (41.9) | n/a | 48 Lbs. (21.8 Kg) |
| SHFWEZ-3D | 67.451\" (171.3) | 15.055\" (38.2) | 65.823\" (167.2) | 66.5\" (168.9) | 14.125\" (35.9) | 5.0\" (12.7) | 33.50\" (85.1) | n/a | 68 Lbs. (30.8 Kg) |
| SHFWEZ-4D | 89.493\" (227.3) | 15.055\" (38.2) | 87.865\" (223.2) | 88.5\" (224.8) | 14.125\" (35.9) | 5.0\" (12.7) | 16.50\" (41.9) | 12.50\" (31.8) | 98 Lbs. (44.4 Kg) |

OPTIONS

Description: Lever Operated Drain Valve

Stock No.: 56360

Drain Manifold: Fabricated to Unit, Required

ELECTRICAL SPECIFICATIONS

| Model | Electrical Ratings 1200 EA. @ 208V / 1600 EA. @ 240V | | | | Electrical Ratings 1600 EA. @ 208V | | | |
|-----------|--|-------------|--------------|------------------|------------------------------------|-------|--------------|--------------|
| | Volts | Watts | Amps 1-Phase | Max Amps 3-Phase | Volts | Watts | Amps 1-Phase | Amps 3-Phase |
| SHFWEZ-2D | 208 / 240 | 2400 / 3200 | 11.5 / 13.3 | 10.0 / 11.6 | 208 | 3200 | 15.4 | 13.4 |
| SHFWEZ-3D | 208 / 240 | 3600 / 4800 | 17.3 / 20 | 10.0 / 11.6 | 208 | 4800 | 23 | 13.4 |
| SHFWEZ-4D | 208 / 240 | 4800 / 6400 | 23.1 / 26.7 | 15.3 / 17.7 | 208 | 6400 | 30.8 | 20.4 |

OPERATION

1. Follow General Operating Instructions on page 3.

CLEANING

1. Follow General Cleaning instructions on page 3.

MODELS TM12L—TOP MOUNT HOT FOOD WELLS W/EZ LOCK

INSTALLATION

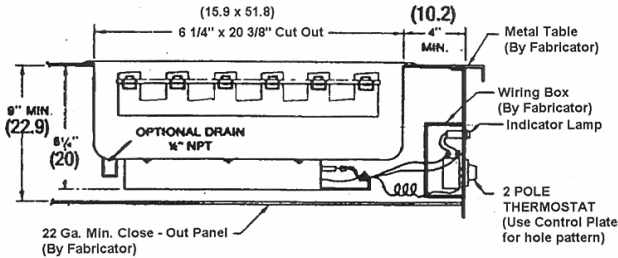

1. Follow General Installation Instructions on page 3.
 2. Make applicable Cut-Out per above table. Note: Unit is designed for installation in stainless steel tops. Optional wood mounting kit available.
 3. Apply putty tape to underside perimeter of the well rim outer edge.
 4. Apply a 1/4" (.6) bead of silicone sealant adjacent to the putty tape on the well flange.
 5. Drop well into opening from the top and push down until entire perimeter of rim is flush with the counter surface.
 6. From below the counter surface insert an 8# to 10# (20 to 25 cm) flat tip screwdriver into the locking ring tab slots and twist in a clockwise motion to lock well in place.
 7. Trim excess putty and sealant from around well rim.
 8. Mount control to front panel using hardware. Maintain 4" (10.2) clearance between well and front panel.
 9. Check nameplate for proper voltage, Connect power.
- Note: Electrically connect units to comply with local and NEC codes.

Recessed Bezel Cut Out

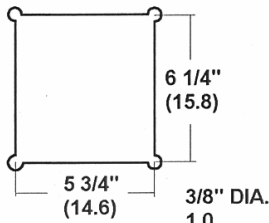

Control Cut Out

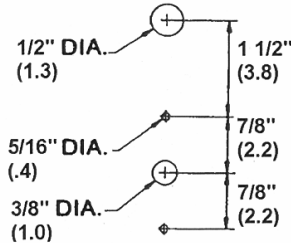

GENERAL SPECIFICATIONS (ALL 90 SERIES)

| Outside Dimensions | Inside Dimensions | Cut Out | Flange | Standard Control | Control Cut Out | Round Corners Standard | Shipping Weight |
|---|---|-----------------------------------|-------------------|--|------------------------------------|------------------------|------------------|
| 8 5/16" x 8 1/4" x 22 5/16" (21.1 x 21.0 x 56.7) | 5 3/4" x 19 15/16" x 6 1/4" (14.6 x 50.6 x 15.9) | 6 1/4" x 20 3/8" (15.9 x 51.8) | 1 3/16" (3.01) | Thermostat has 36" (91.4) capillary effective length 28" (66.) | Use Control Plate for hole pattern | 1" (2.5) Radiused. | 17 lbs. (7.7 kg) |

OPTION SPECIFICATIONS

| Thermostat | Recessed Bezel | Wood Mounting Kit, Stock No.'s | Wood Mounting Kit, Cut Out | Drain Standard w/Model No.'s | Drain Location | Drain Coupling | Electrical Code Kit |
|--|---|--------------------------------|----------------------------|------------------------------|---|-------------------------------------|-------------------------|
| With 72" (182.9) Capillary Effective Length 62" (157.5) Add (-72) to Model No.'s | Stock No.'s 56370 This is only the Recessed Bezel | N/A | N/A | TM-12L Add "D" For Drain | 1 11/16" X 1 11/16" (4.3) x (4.3) From Back Right Corner. | 1/2 NPT Stainless 1 1/2" (3.8) Long | Add (UL) to Stock No.'s |

BOTTOM HOUSING
Insulated on bottom of element housing.

THERMOSTATS
Equipped with an off-position, using point system and permanent type dial. 250v. 25 AMP, double pole.

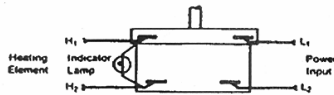

THERMOSTAT

Thermostat is 2 pole and breaks both lines at "OFF" position. Units are prewired to Thermostat. Make line connections as shown. All wiring should be done in accordance with local codes. Use minimum 14 AWG copper wire rated at least 90°C. Optional recessed bezel equipped with 1/2" conduit knockouts.

ELECTRICAL SPECIFICATIONS PER UNIT

| Model No.'s | Volts | Watts | 1PH AMPS |
|-------------|-------|-------|-----------|
| TM-12L | 120v | 500w | 4.17 AMPS |

OPERATION

1. Follow General Operating Instructions on page 3.

CLEANING

1. Follow General Cleaning instructions on page 3.

▲All models are UR. The UL Models include flexible conduit, electrical box & recessed bezel and are designated with a "UL" suffix on the Model & Stock Nos.

BUILT-IN HOLDING DRAWERS "HDD-_B"

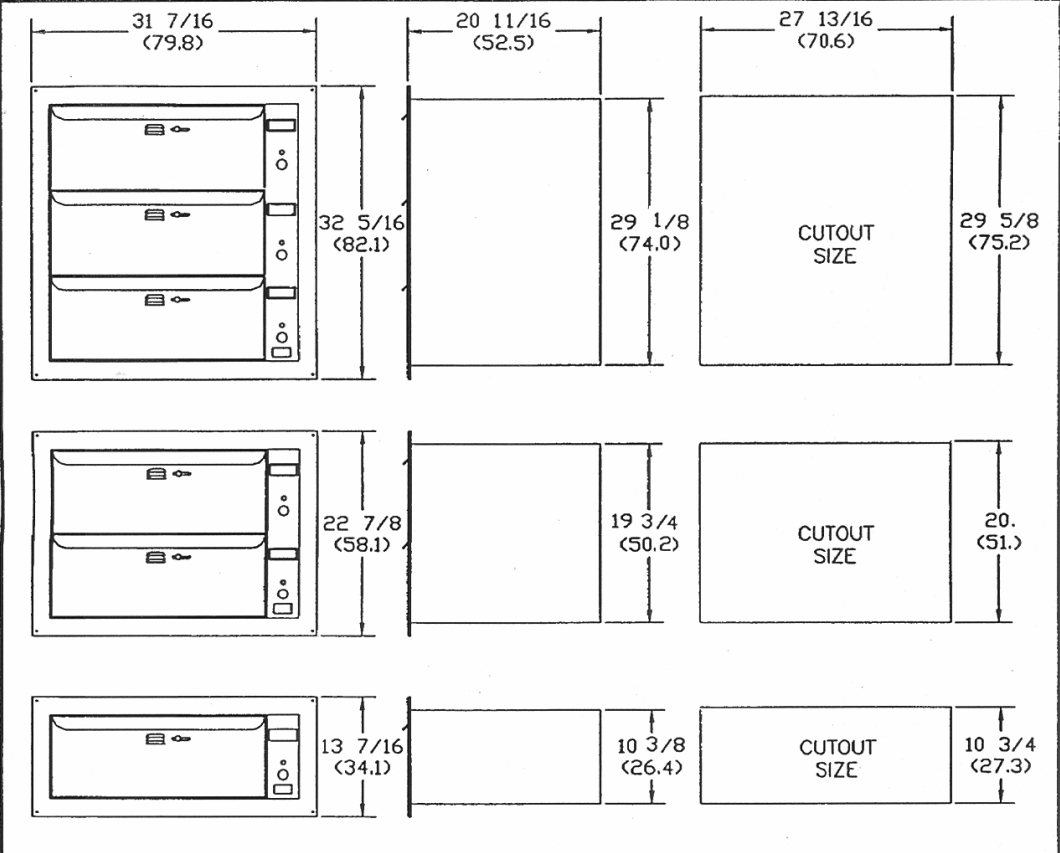

OPERATIONS

- Follow General Cleaning instructions on page 3.
- Set thermostat control knob to desired setting and preheat each drawer for 30 minutes.
- Place food product directly into drawer pans or use any combination of full or fractional pans up to 6" (15.2 cm) deep.
- Set front drawer vent knob to desired position to maintain food product moisture.
- Perforated pans may be used with a damp towel or small amount of water in the drawer pan to prevent food "dryout".
CAUTION: Use no more than 1 quart (1 litre) water.
- If too much moisture accumulates around drawer front or vent, reduce temperature or move vent knob to "DRY" position.
- Recommended settings:**

| Product | Temperature | Vent |
|--------------|---------------------|-------|
| Rolls, bread | 160-180° (71-82° C) | Moist |
| Vegetables | 170-180° (77-82° C) | Moist |
| Meats | 170-180° (77-82° C) | Moist |

NOTE: Temperature and vent settings will require adjustment according to type and quantity of food and the number of times the drawer is opened during operation.

INSTALLATION INSTRUCTIONS

- Mark cut-out front of counter and fabricate hole.
- Fabricate support rails and rear brace, **NOTE:** Weight of unit and load must be supported by rails and brace.
HD1B, 118 Lb. (53.5 Kg.) Minimum
HD2B, 213 Lb. (96.6 Kg.) Minimum
HD3B, 309 Lb. (148.2 Kg.) Minimum
- Remove drawers from unit. Apply RTV to inside of mounting frame.
- Slide unit into opening and drill mounting holes using a 7/64 (.3 cm) drill bit. **NOTE:** If installing unit into an opening that does not allow access to top of unit wiring must be complete before sliding unit into cabinet.
- Secure unit to counter front using #8 (4mm) screws provided. Wipe excess RTV around front mounting frame.
- Remove top panel. For wiring connections unit is provided with a .875 (2.2 cm) Dia. Knock-out and field wiring terminal block with .250 (.64 cm) quick disconnect terminals. Unit is to be electrically installed by a qualified electrician in accordance with NEC and any local installation codes. Wire with minimum #14 GA. (1mm²) suitable for at least 90° C (190°F).
- Replace drawer assemblies.

DAILY CLEANING

- Follow General Cleaning instructions on page 3.
- Remove any inset pans & drawer pans. Wash thoroughly in the sink or dishwasher.
- Remove drawers: Remove pans and pan inserts. Extend drawer and lift up on the front to clear the drawer stop. Lower drawer and pull straight out.

HOLDING DRAWERS "HDS"

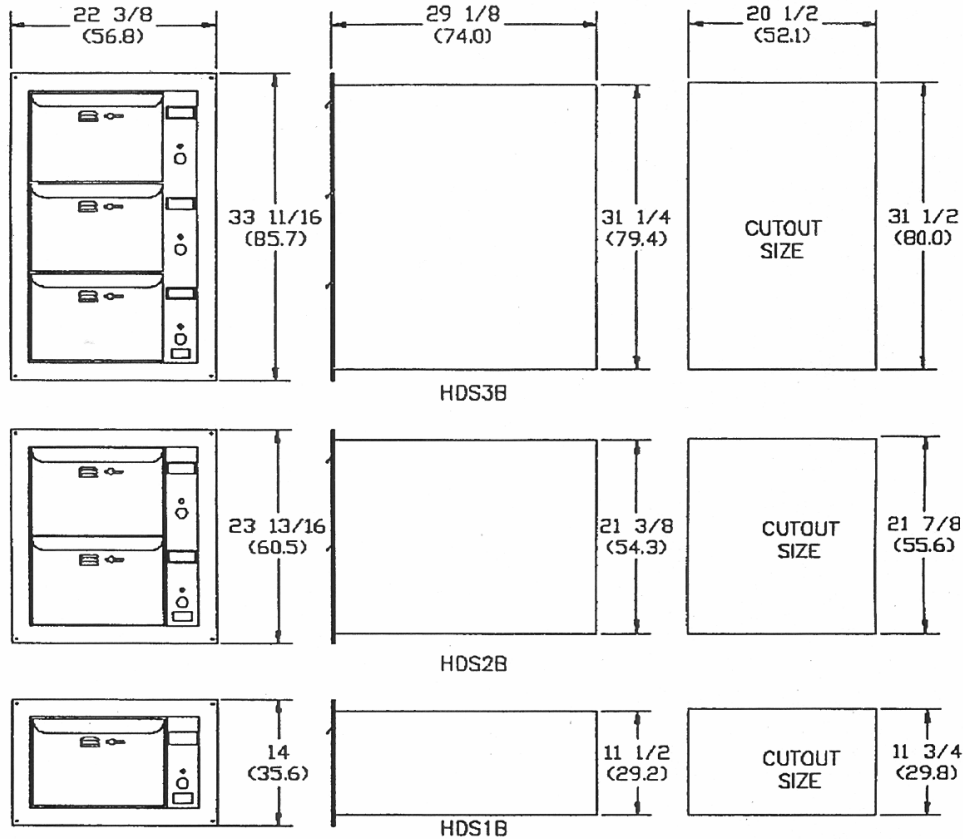

OPERATIONS

1. Follow General Cleaning instructions on page 3.
2. Set thermostat control knob to desired setting and preheat each drawer for 30 minutes.
3. Place food product directly into drawer pans or use any combination of full or fractional pans up to 6" (15.2 cm) deep.
4. Set front drawer vent knob to desired position to maintain food product moisture.
5. Perforated pans may be used with a damp towel or small amount of water in the drawer pan to prevent food "dryout".
6. If too much moisture accumulates around drawer front or vent, reduce temperature or move vent knob to "DRY" position.
7. Recommended settings:

| Product | Temperature | Vent |
|--------------|---------------------|-------|
| Rolls, bread | 160-180° (71-82° C) | Moist |
| Vegetables | 170-180° (77-82° C) | Moist |
| Meats | 170-180° (77-82° C) | Moist |

NOTE: Temperature and vent settings will require adjustment according to type and quantity of food and the number of times the drawer is opened during operation.

INSTALLATION INSTRUCTIONS

1. Mark cut-out front of counter and fabricate hole.
2. Fabricate support rails and rear brace, **NOTE:** Weight of unit and load must be supported by rails and brace.
 HDS1B, 116 Lb. (52.6 Kg.) Minimum
 HDS2B, 212 Lb. (96.2 Kg.) Minimum
 HDS3B, 308 Lb. (139.7 Kg.) Minimum
3. Remove drawers from unit. Apply RTV to inside of mounting frame.
4. Slide unit into opening and drill mounting holes using a 7/64 (.3 cm) drill bit. **NOTE:** If installing unit into an opening that does not allow access to top of unit wiring must be complete before sliding unit into cabinet.
5. Secure unit to counter front using #8 (4mm) screws provided. Wipe excess RTV around front mounting frame.
6. Remove top panel. For wiring connections unit is provided with a .875 (2.2 cm) Dia. Knock-out and field wiring terminal block with .250 (.64 cm) quick disconnect terminals. Unit is to be electrically installed by a qualified electrician in accordance with NEC and any local installation codes. Wire with minimum #14 GA. (1mm²) suitable for at least 90° C (190°F).
7. Replace drawer assemblies.

DAILY CLEANING

1. Follow General Cleaning instructions on page 3.
2. Remove any inset pans & drawer pans. Wash thoroughly in the sink or dishwasher.
3. Remove drawers: Remove pans and pan inserts. Extend drawer and lift up on the front to clear the drawer stop. Lower drawer and pull straight out.

HOLDING DRAWERS "HD" & "HDS"— CONTINUED

GENERAL SPECIFICATIONS ("HD" HOLDING DRAWERS)

| Description | Outside Dimensions | Inside Dimensions | Cut Out | Drawer Extension | Unit Weight | Shipping Weight |
|--------------|---|---|--|------------------|-----------------------|-----------------------|
| One Drawer | 13 ⁷ / ₁₆ " H x 31 ¹ / ₁₆ " W x 20 ¹ / ₁₆ " D (34.1 H x 79.8 W x 53.2 D) | 10 ¹ / ₂ " H x 27 ⁹ / ₁₆ " W x 20 ¹ / ₁₆ " D (26.7 H x 70 W x 52.5 D) | 10 ³ / ₄ " H x 27 ¹³ / ₁₆ " W (27.3 H x 70.6 W) | 15" (38.1) | 70 Lbs. (31.8 Kg) | 80 Lbs. (36.3 Kg) |
| Two Drawer | 22 ⁷ / ₁₆ " H x 31 ¹ / ₁₆ " W x 20 ¹ / ₁₆ " D (58.1 H x 79.8 W x 53.2 D) | 19 ¹ / ₁₆ " H x 27 ⁹ / ₁₆ " W x 20 ¹ / ₁₆ " D (50.6 H x 70 W x 52.5 D) | 20 ¹ / ₄ " H x 27 ¹³ / ₁₆ " W (51.4 H x 70.6 W) | 15" (38.1) | 117 Lbs. (53.1 Kg) | 127 Lbs. (57.6 Kg) |
| Three Drawer | 32 ¹ / ₁₆ " H x 31 ¹ / ₁₆ " W x 20 ¹ / ₁₆ " D (82.1 H x 79.8 W x 53.2 D) | 29 ⁹ / ₁₆ " H x 27 ⁹ / ₁₆ " W x 20 ¹ / ₁₆ " D (74.6 H x 70 W x 52.5 D) | 29 ⁵ / ₈ " H x 27 ¹³ / ₁₆ " W (75.2 H x 70.6 W) | 15" (38.1) | 165 Lbs. (74.8 Kg) | 185 Lbs. (83.9 Kg) |

Stock # 14900 Perforated Well - Bottom - Ship Wt. 3 Lbs. (1.4 Kg)

GENERAL SPECIFICATIONS ("HDS" HOLDING DRAWERS)

| Description | Outside Dimensions | Inside Dimensions | Cut Out | Drawer Extension | Unit Weight | Shipping Weight |
|--------------|---|--|--|--|-----------------------|-----------------------|
| One Drawer | 14" H x 22 ³ / ₈ " W x 29 ¹ / ₈ " D (35.6 H x 56.8 W x 74 D) | 11 ¹ / ₂ " H x 20 ¹ / ₄ " W x 28 ⁷ / ₈ " D (29.2 H x 51.4 W x 73.3 D) | 11 ³ / ₄ " H x 20 ¹ / ₂ " W (29.8 H x 52.1 W) | 23 ³ / ₄ " (60.3) | 68 Lbs. (30.8 Kg) | 78 Lbs. (35.4 Kg) |
| Two Drawer | 23 ¹ / ₁₆ " H x 22 ³ / ₈ " W x 29 ¹ / ₈ " D (60.5 H x 56.8 W x 74 D) | 21 ¹ / ₈ " H x 20 ¹ / ₄ " W x 28 ⁷ / ₈ " D (54.3 H x 51.4 W x 73.3 D) | 21 ¹ / ₈ " H x 20 ¹ / ₂ " W (55.6 H x 52.1 W) | 23 ³ / ₄ " (60.3) | 116 Lbs. (52.6 Kg) | 126 Lbs. (57.2 Kg) |
| Three Drawer | 33 ¹ / ₁₆ " H x 22 ³ / ₈ " W x 29 ¹ / ₈ " D (85.7 H x 56.8 W x 74 D) | 31 ¹ / ₄ " H x 20 ¹ / ₄ " W x 28 ⁷ / ₈ " D (79.4 H x 51.4 W x 73.3 D) | 31 ¹ / ₂ " H x 20 ¹ / ₂ " W (80. H x 52.1 W) | 23 ³ / ₄ " (60.3) | 164 Lbs. (74.4 Kg) | 184 Lbs. (83.5 Kg) |

Stock # 14900 Perforated Well - Bottom - Ship Wt. 3 Lbs. (1.4 Kg)

ELECTRICAL RATING ("HD" & "HDS")

| Model | 120V | 208V | 240V | 230V |
|---------|-----------------|----------------|----------------|----------------|
| HDS/HD1 | 450W, 3.8 Amp | 450W, 2.2 Amp | 450W, 1.9 Amp | 414W, 1.8Amp |
| HDS/HD2 | 900W, 7.5 Amp | 900W, 4.3 Amp | 900W, 3.8 Amp | 828W, 3.6Amp |
| HDS/HD3 | 1350W, 11.2 Amp | 1350W, 6.5 Amp | 1350W, 5.6 Amp | 1242W, 5.4 Amp |

DRAWER ASSEMBLIES

ALL MODELS 415 420 PLUS (Liner Pans: 412, 418, 422, 488)

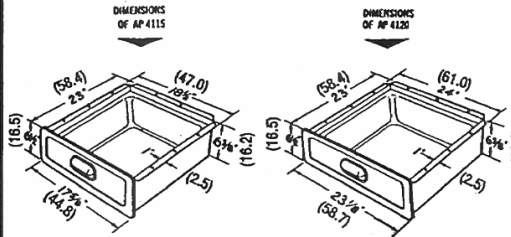

INSTALLATION

1. Remove internal housing (the section w/ drawer front) for easier handling.
2. Transfer Mounting hole configuration in external housing flange to underside of counter or braces.
3. Fasten securely with weld studs or sheet metal screws.
4. Replace internal housing by engaging drawer slides.
5. Stainless steel liner pans are recommended for direct food contact.

DRAWER ASSEMBLY SPECIFICATIONS

HEAVY-DUTY DRAWER ASSEMBLIES

| Stock # | Model # | Dimensions Width w/Flange x Length w/Flange x Depth | Housing Metal | Liner Pan Metal | Ship. Wt. |
|---------|---------|--|---------------|------------------------|------------------|
| 33524 | HD-415 | 18 1/2" x 22" x 6 1/2" (47.0 x 55.9 x 16.5) | 18 gauge SS | 20 gauge SS Pan #33415 | 31 lbs. (14.1KG) |
| 33564 | HD-420 | 24" x 22" x 6 1/2" (61.0 x 55.9 x 16.5) | 18 gauge SS | 20 gauge SS Pan #33420 | 39 lbs. (17.7KG) |

STANDARD DRAWER ASSEMBLIES

| | | | | | |
|-------|--------|---|-------------|------------------------|------------------|
| 33514 | SS-415 | 18 1/2" x 22" x 6 1/2" (47.0 x 55.9 x 16.5) | 20 gauge SS | 20 gauge SS Pan #33415 | 26 lbs. (11.8KG) |
| 33515 | SG-415 | 18 1/2" x 22" x 6 1/2" (47.0 x 55.9 x 16.5) | 18 gauge GZ | 20 gauge SS Pan #33415 | 27 lbs. (12.2KG) |
| 33517 | GG-415 | 18 1/2" x 22" x 6 1/2" (47.0 x 55.9 x 16.5) | 18 gauge GZ | 20 gauge GZ Pan #35415 | 31 lbs. (14.1KG) |
| 33574 | SS-420 | 24" x 22" x 6 1/2" (61.0 x 55.9 x 16.5) | 20 gauge SS | 20 gauge SS Pan #33420 | 30 lbs. (16.2KG) |
| 33575 | SG-420 | 24" x 22" x 6 1/2" (61.0 x 55.9 x 16.5) | 18 gauge GZ | 20 gauge SS Pan #33420 | 31 lbs. (14.1KG) |
| 33577 | GG-420 | 24" x 22" x 6 1/2" (61.0 x 55.9 x 16.5) | 18 gauge GZ | 20 gauge GZ Pan #35420 | 35 lbs. (15.9KG) |

SS = Stainless Steel

GZ = Galvanized

DIE STAMPED DRAWER PAN SPECIFICATIONS

DIE STAMPED DRAWER PAN SPECIFICATIONS

| Stock # | Model # | Inside Dimensions (W/L/D) | Trim Dimensions | Stan. Case | Ship. Wt. |
|---------|-----------|--|---------------------------------|------------|-------------------|
| 33412 | AP412S | 12 1/4" x 20 1/4" x 5" (31.1 x 51.4 x 12.7) | 13 3/4" x 21 3/4" (34.9 x 55.2) | 5 | 19 lbs. (8.6 Kg) |
| 33415 | AP415S | 14 5/8" x 20 5/8" x 5" (37.1 x 51.1 x 12.7) | 16 1/8" x 21 1/8" (41.0 x 54.9) | 4 | 27 lbs. (12.2 Kg) |
| 35415 | AP415GZ | 14 5/8" x 20 5/8" x 5" (37.1 x 51.1 x 12.7) | 16 1/8" x 21 1/8" (41.0 x 54.9) | 4 | 29 lbs. (13.2 Kg) |
| 33488 | AP488S | 18 1/4" x 18 1/4" x 5" (46.4 x 46.4 x 12.7) | 19 3/4" x 19 3/4" (50.2 x 50.2) | 5 | 35 lbs. (15.9 Kg) |
| 33418 | AP418S | 18 1/4" x 22 1/4" x 5" (46.4 x 56.5 x 12.7) | 19 3/4" x 23 3/4" (50.2 x 60.3) | 5 | 36 lbs. (16.3 Kg) |
| 33420 | AP420S | 20 3/8" x 20 3/8" x 5" (51.3 x 51.3 x 12.7) | 21 1/8" x 21 1/8" (55.1 x 55.1) | 4 | 34 lbs. (15.4 Kg) |
| 35420 | AP420GZ | 20 3/8" x 20 3/8" x 5" (51.3 x 51.3 x 12.7) | 21 1/8" x 21 1/8" (55.1 x 55.1) | 4 | 40 lbs. (18.1 Kg) |
| 33422 | AP422S | 20 1/8" x 22 1/8" x 5" (51.1 x 56.2 x 12.7) | 21 3/8" x 23 3/8" (54.9 x 60.0) | 5 | 43 lbs. (19.5 Kg) |
| 33421 | AP420-8S | 20 3/8" x 20 3/8" x 8" (51.3 x 51.3 x 20.3) | 21 1/8" x 21 1/8" (55.1 x 55.1) | 2 | 24 lbs. (10.9 Kg) |
| 33451 | AP420-10S | 20 3/8" x 20 3/8" x 10" (51.3 x 51.3 x 25.4) | 21 1/8" x 21 1/8" (55.1 x 55.1) | 1 | 15 lbs. (6.8 Kg) |

DRAWER FRONT SPECIFICATIONS*

| Stock # | Model # | Material | Dimensions (HxW) | Stan. Case | Ship. Wt. |
|---------|---|-------------|--------------------------------|------------|-------------------|
| 34015 | 415-5-C | 20 gauge SS | 6 1/2" x 17 3/8" (16.6 x 44.8) | 24 | 45 lbs. (20.4 Kg) |
| 34020 | 420-5-C | 20 gauge SS | 6 1/2" x 23 3/8" (16.6 x 58.7) | 24 | 50 lbs. (22.7 Kg) |
| 37156 | - 150 lb. (60.0 Kg) Heavy-Duty Drawer Slide Kit | | | 1 Pair | 2 lbs.* (1.0 Kg) |
| 37152 | - Angle Bracket Assembly | | | 1 Pair | 1/2 lb.* (0.2 Kg) |

CLEANING

1. Remove liner pan for sink or dishwasher cleaning.
2. Always clean equipment thoroughly before first use. Surface clean unit daily. Use warm soapy water. Mild cleansers and plastic scouring pads may be used to remove any food or water scale.
3. Any service should be performed by an authorized APW Service Agency.

SINKS

ALL MODELS: APS

12"(45.4) WIDE BOWL(S)

SINGLE SINK (STOCK #55421)

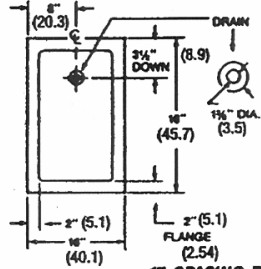

10"(25.4) WIDE BOWL(S)

SINGLE SINK (STOCK #74001)

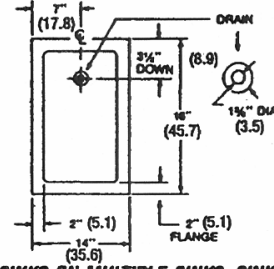

9"(22.9) WIDE BOWL(S)

SINGLE SINK (STOCK #70001)

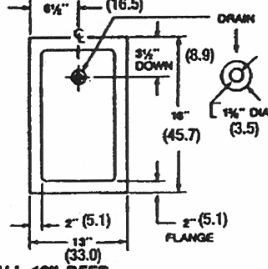

1" SPACING BETWEEN SINKS ON MULTIPLE SINKS. SINKS ARE ALL 10" DEEP.

DOUBLE SINK (STOCK #55422)

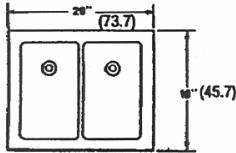

DOUBLE SINK (STOCK #74002)

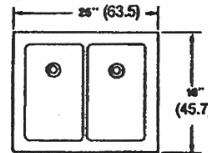

DOUBLE SINK (STOCK #70002)

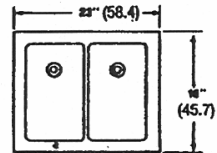

TRIPLE SINK (STOCK #55423)

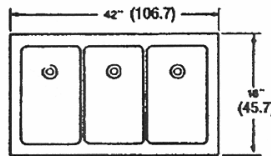

TRIPLE SINK (STOCK #74003)

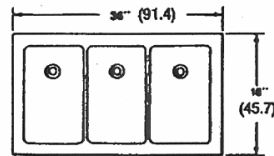

TRIPLE SINK (STOCK #70003)

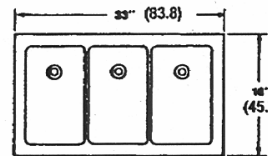

QUADRUPLE SINK (STOCK #55424)

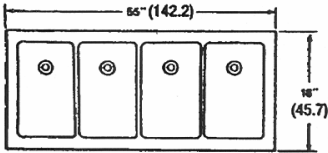

QUADRUPLE SINK (STOCK #74004)

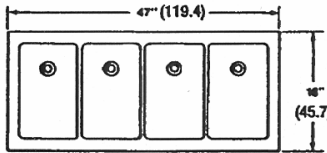

QUADRUPLE SINK (STOCK #70004)

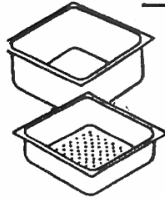
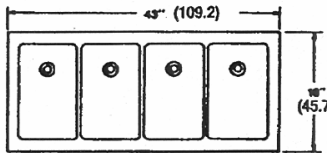

Scullery Sink & Strainer Pan

| Description | Outside Dim. LxWxD | Inside Dim. | Flange |
|----------------------|---|---|--------------|
| Scullery Sink #55470 | 21 1/4" x 21 1/4" x 8" (55.1 x 55.1 x 20.3) | 20 3/4" x 20 3/4" x 8" (51.3 x 51.3 x 20.3) | 3/4" (1.9) |
| Strainer Pan #55471 | 21" x 21" x 6" (53.3 x 53.3 x 15.2) | 18 1/4" x 18 1/4" x 6" (46.4 x 46.4 x 15.2) | 1 3/8" (2.8) |

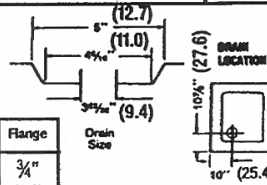

Drain Hole for All Standard Sinks

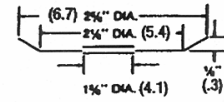

INSTALLATION

1. Install sinks according to NSF and/or Local Codes.
2. All APW sinks are prepunched for drains, only holes for fixtures & fixtures are the responsibility of the fabricator.

CLEANING

1. Always clean equipment thoroughly before first use.
2. Clean bowls daily using warm, soapy water. Mild cleansers & plastic scouring pads may be used to remove food scum and water scale.

APW WYOTT EQUIPMENT LIMITED WARRANTY

APW Wyott Foodservice Equipment Company warrants its equipment against defects in materials and workmanship, subject to the following conditions:

This warranty applies to the original owner only and is not assignable.

Should any product fail to function in its intended manner under normal use within the limits defined in this warranty, at the option of APW Wyott such product will be repaired or replaced by APW Wyott or its Authorized Service Agency. APW Wyott will only be responsible for charges incurred or service performed by its Authorized Service Agencies. The use of other than APW Wyott Authorized Service Agencies will void this warranty and APW Wyott will not be responsible for such work or any charges associated with same. The closest APW Wyott Authorized Service Agent must be used.

This warranty covers products shipped into the 48 contiguous United States, Hawaii, metropolitan areas of Alaska and Canada. There will be no labor coverage for equipment located on any island not connected by roadway to the mainland.

Warranty coverage on products used outside the 48 contiguous United States, Hawaii, and metropolitan areas of Alaska and Canada may vary. Contact the international APW Wyott distributor, dealer, or service agency for details.

Time Period

One year for parts and one year for labor, effective from the date of purchase by the original owner. The Authorized Service Agency may, at their option, require proof of purchase. Parts replaced under this warranty are warranted for the un-expired portion of the original product warranty only.

Exceptions

- ***Gas/Electric Cookline:** Models GCB, GCRB, GF, GGM, GGT, CHP-H, EF, EG, EHP. Three (3) Year Warranty on all component parts, except switches and thermostats. (2 additional years on parts only. No labor on second or third year.)
- ***Broiler Briquettes, Rock Grates, Cooking Grates, Burner Shields, Fireboxes:** 90 Day Material Only. No Labor.
- ***Heat Strips:** Models FD, FDL, FDD, FDDL. Two (2) Year Warranty on element only. No labor second year.
- ***Glass Windows, Doors, Seals, Rubber Seals, Light Bulbs:** 90 Day Material Only. No Labor.

In all cases, parts covered by extended warranty will be shipped FOB the factory after the first year.

Portable Carry In Products

Equipment weighing over 70 pounds or permanently installed will be serviced on-site as per the terms of this warranty. Equipment weighing 70 pounds or under, and which is not permanently installed, i.e. with cord and plug, is considered portable and is subject to the following warranty handling limitations. If portable equipment fails to operate in its intended manner on the first day of connection, or use, at APW Wyott's option or its Authorized Service Agency, it will be serviced on site or replaced.

From day two through the conclusion of this warranty period, portable units must be taken to or sent prepaid to the APW Wyott Authorized Service Agency for in-warranty repairs. No mileage or travel charges are allowed on portable units after the first day of use. If the customer wants on-site service, they may receive same by paying the travel and mileage charges. Exceptions to this rule: (1) countertop warmers and cookers, which are covered under the Enhanced Warranty Program, and (2) toasters or rollergrills which have in store service.

Exclusions

The following conditions are not covered by warranty:

- *Equipment failure relating to improper installation, improper utility connection or supply and problems due to ventilation.
- *Equipment that has not been properly maintained, calibration of controls, adjustments, damage from improper cleaning and water damage to controls.
- *Equipment that has not been used in an appropriate manner, or has been subject to misuse or misapplication, neglect, abuse, accident, alteration, negligence, damage during transit, delivery or installation, fire, flood, riot or act of god.
- *Equipment that has the model number or serial number removed or altered.

If the equipment has been changed, altered, modified or repaired by other than an Authorized Service Agency during or after the warranty period, then the manufacturer shall not be liable for any damages to any person or to any property, which may result from the use of the equipment thereafter.

This warranty does not cover services performed at overtime or premium labor rates. Should service be required at times which normally involve overtime or premium labor rates, the owner shall be charged for the difference between normal service rates and such premium rates. APW Wyott does not assume any liability for extended delays in replacing or repairing any items beyond its control.

In all cases, the use of other than APW Wyott Authorized OEM Replacement Parts will void this warranty.

This equipment is intended for commercial use only. Warranty is void if equipment is installed in other than commercial application.

Water Quality Requirements

Water supply intended for a unit that has in excess of 3.0 grains of hardness per gallon (GPG) must be treated or softened before being used. Water containing over 3.0 GPG will decrease the efficiency and reduce the operation life of the unit.

Note: Product failure caused by liming or sediment buildup is not covered under warranty.

“THE FOREGOING WARRANTY IS IN LIEU OF ANY AND ALL OTHER WARRANTIES EXPRESSED OR IMPLIED INCLUDING ANY IMPLIED WARRANTY OF MERCHANTABILITY OR FITNESS FOR PARTICULAR PURPOSES AND CONSTITUTES THE ENTIRE LIABILITY OF APW WYOTT. IN NO EVENT DOES THE LIMITED WARRANTY EXTEND BEYOND THE TERMS STATED HEREIN.”