



OPERATION MANUAL
DANTE SERIES GAS CHARBROILERS
SERIES: XXE



BUILT BY CRAFTSMEN. TESTED BY TIME®.



XXE CHARBROILER OPERATION MANUAL

CHARBROILER OPERATION MANUAL

Models:

Dante XXE

Bakers Pride Oven Company, LLC is a wholly owned subsidiary of Standex International Corporation.

All gas operated Bakers Pride® charbroilers are intended for use with the type of gas specified on the rating plate and for installation will be in accordance with National Fuel Gas Code ANSI Z223.1 (latest edition).

⚠ WARNING

FOR YOUR SAFETY: Do not store or use gasoline or other flammable vapors or liquids in the vicinity of this or any other appliance.

⚠ WARNING

After the gas supply has been connected to your unit, it is extremely important to check piping for possible leaks. To do this, use soap and water solution or solutions which are expressly made for this purpose. DO NOT USE matches, candles, flames, or other sources of ignition since these methods are extremely dangerous.

Post in a prominent location instructions to be followed in the event you smell gas. Obtain these instructions from your local gas supplier.

⚠ WARNING

California Residents Only

WARNING: This product can expose you to chemicals including chromium which is known to the State of California to cause cancer and birth defects or other reproductive harm. For more information go to www.P65Warnings.ca.gov.

⚠ WARNING

Improper installation, adjustment, alteration, service or maintenance can cause property damage, injury or death. Read the installation, operating and maintenance instructions thoroughly before installing or servicing this equipment.

⚠ WARNING

Instructions must be posted in a prominent location. All safety precautions must be taken in the event the user smells gas. Safety information can be obtained from your local gas supplier.

Please retain this manual for future references.

This equipment is design engineered for commercial use only.

This equipment has been engineered to provide you with year round dependable service when used according to the instructions in this manual and standard commercial kitchen practices.



BAKERS PRIDE OVEN COMPANY, LLC.

1307 N. Watters Rd., Suite 180
Allen, TX 75013

Phone: 800.527.2100 | Fax: 914.576.0605 | www.bakerspride.com



TABLE OF CONTENTS

INSTALLATION INSTRUCTIONS	1	OPERATING INSTRUCTIONS	4
INSTALLATION	1	LIGHTING PROCEDURE	4
CLEARANCES	2	BROILING	4
GAS CONNECTION	2	MAINTENANCE	4
BURNERS	2	SERVICE	4
RADIANTS	2	CARE & CLEANING	4
TOP GRATES	2	CLEANING TOOLS	4
LIGHTING INSTRUCTIONS	3	TROUBLESHOOTING CHART	5
GREASE PAN	3	MANIFOLD & VALVE ASSEMBLY VIEWS	5
GRIDDLE PLATE	3	PARTS LIST AND EXPLODED VIEWS	6
ADDITIONAL INSTALLATION INSTRUCTIONS	3	WARRANTY	11
INSTALLATION WITH CASTERS	3		

SAFETY PRECAUTIONS

⚠ DANGER

This symbol warns of imminent hazard which will result in serious injury or death.

⚠ WARNING

This symbol refers to a potential hazard or unsafe practice, which could result in serious injury or death.

⚠ CAUTION

This symbol refers to a potential hazard or unsafe practice, which may result in or moderate injury or product or property damage.

NOTICE

This symbol refers to information that needs special attention or must be fully understood even though not dangerous.

INSTALLATION INSTRUCTIONS

Installation Instructions

- (A) INSTALLATION of this broiler must conform with the latest edition of National Fuel Gas Code and/or local codes, (the American National Standard 2-223.1 in USA and CAN/CGA-B149.1 or 2 Installation Code in Canada). In Europe, this appliance must be installed in conformity with current regulations and used only in a well ventilated space.
- (B) In MASSACHUSETTS, All gas products must be installed by a "Massachusetts" licensed plumber or gas fitter. Ventilation hoods must be installed in accordance with NFPA-96, current edition, with interlocks as described in that standard.



INSTALLATION INSTRUCTIONS

Acceptable Clearances:

- (A) **USA and Canada.** Due to intense heat generated by radiation, in USA and Canada these broilers should be installed in non-combustible locations only, including the areas above the grate level. Minimum Clearance From Non-Combustible Construction:

Right	Left	Back
50mm (2")	50mm (2")	50mm (2")

- (B) **European Community Countries**
Minimum clearance from:

	Right	Left	Back	Floor
Combustible construction	250mm	250mm	250mm	150mm
Non-combustible construction	50mm	50mm	50mm	100mm

Gas Connection:

The gas pressure regulator supplied must be installed at the gas inlet of each broiler unless required otherwise by local codes. Each regulator is adjusted to yield a manifold pressure of 3.5" water column (9 mbar) for natural gas or 10" water column (25 m bar) for propane gas. Units for propane gas are available for use in USA and Canada only.

Recommended minimum gas supply lines are listed below:

All XXE Models: 3/4" (19 mm)

NOTICE

A shut-off valve in a readily accessible location must be mounted on the gas supply line before the unit.

For units using propane gas supply In USA and Canada lines less than 1/2" (12.7 mm) inside diameter should not be used.

On the XXE series, the gas connection is located on the right rear of the unit.

CAUTION

Be sure to cap whichever side is not connected.

When making gas pipe connections, pipe joint compound resistant to the action of liquefied petroleum gases should be used.

The broiler and its individual shutoff valve must be disconnected from the gas supply piping system during any pressure testing of that system at test pressure in excess of 1/2 psig (3.45 kpa).

The broiler must be isolated from the gas supply piping system by closing its individual manual shutoff valve during any pressure testing of the gas supply piping system at test pressures equal to or less than 1/2 psig (3.45 kpa).

Burners

Check to see that air mixer caps on the front of all burners are adjusted and tightened, allowing half the opening to show.

To install the burners:

- (A) Place the front venturi end of the burner into the valve assembly by fitting the center hole of the air mixer cap over the brass orifice.
- (B) Drop the two ends of the burners over the burner support pins in the front and back of the chamber.

Radiants

Mount the "A" shaped radiants over the burners with each end mounted on special supports on the front and rear of the chamber. A radiant should be mounted over each burner assembly.

Top Grates

Place a grate over each of the radiants. For normal operation the pointed side of the grate is facing up. For use with foods that require extra support, the flat side may be used.

On XXE models, grates can be placed on three levels; two positions are built into the rear of the unit; the third position requires a special adapter which is supplied with the unit.

The adapter covers only half of the broiler. To cover the entire unit, optional adapters can be ordered.



INSTALLATION INSTRUCTIONS

Lighting:

Each burner has a standing pilot burner which must be lit before the burners can be lit. To light the pilot burners:

- (A) Turn all broiler valves to off position
- (B) Open main gas shut off valve (provided by customer).
- (C) Press, turn counterclockwise and hold the burner control knob to the pilot burner ignition position.
- (D) Using a lit taper, light the pilot burner.
- (E) Release the knob after 30 seconds. Pilot burner should stay lit. If the pilot burner does not remain lit, wait for 5 minutes and repeat steps C and D. Hold the knob pressed longer before releasing.
- (F) With a screwdriver adjust the pilot burner flame to about 1/2" (12.7 mm). Turn the adjusting screw clockwise to reduce or counterclockwise to increase the pilot burner flame.
- (G) Each burner may now be adjusted to the desired flame size by turning the individual burner valve knob.
- (H) Turn the knob to the pilot burner ignition position to shut down the main burner.
- (I) Turn the knob to off position to shut down the pilot burners.

NOTICE

Wait five minutes before attempting to relight the pilot burners.

Grease Pan

A grease pan is provided below the burners to hold any grease that drips down past the radiants while broiling. An additional grease drawer is provided in the front right corner of the grease pan to collect the grease from the grease drain in the front which in turn drains into the grease collector.

Water is usually added to the grease pan to reduce flare-up and flash back. The grease drip will extinguish as it hits the water.

Griddle Plate (Optional)

Griddle plates should not cover more than 50% of the BROILING area. Each Griddle Plate fits on top of two grates. It is not necessary to remove the top grates and radiants before installing the griddle plate.

Additional Installation Instructions

- (A) Keep the area around the broiler free and clear of combustible materials.
- (B) The provision of an adequate air supply to your broiler is essential. Provide for sufficient outside air to enter the broiling area and assure that this air flow is not obstructed.
- (C) Air enters the burner area from the front of your broiler. Assure that this area is kept open and unobstructed.
- (D) Servicing is accomplished through the front and top of the broiler. Assure that this area is kept unobstructed for proper servicing and operation.

Installation With Casters

- (A) Install the casters with wheel brakes on the front of the appliance.
- (B) Installation should be made with a connector that complies with the latest edition of the Standard for Connectors for Movable Gas Appliances (ANSI Z21.69 in USA, CAN/CGA-6.16 in Canada) and a quick disconnect device that complies with the latest edition of the Standard for Quick Disconnect Devices for use with gas fuel (ANSI Z21.41 in USA, CAN1-6.9 in Canada). Adequate means must be provided to limit the movement of the appliance without depending on the connector and any quick disconnect device or its associated piping to limit the appliance movement.
- (C) The restraint should be attached to the center of the back about 1/2" (12.7mm) from the bottom.
- (D) If disconnection of the restraint is necessary, the restraint should be reconnected after the appliance has been returned to its originally installed position.



OPERATING INSTRUCTIONS

Lighting Procedures

See Lighting Section under Installation Instructions.

Broiling

Broiler top grate must be hot enough to make black char-marks when starting to broil.

Adequate preheating time is necessary for the food to release from the broiler and to cook properly. Allow the unit to preheat for 20-25 minutes before broiling.

- (A) Do not press the juice out of the meat because that will cause dry products.
- (B) After broiling, allow the meat to sit covered on a heated platter for 2-5 minutes before cutting. This will allow the juices to “settle” and the product will be more moist.

- (C) Do not use forks or other sharp objects to poke holes in the meat. Do not cut the meat as it cooks.
- (D) Thick pieces of meat require a longer broiling time with less flare-up. Reduce flare up by trimming excess fat for a longer broil time without burning.
- (E) Keep the unit clean. Food caught between the grate will not allow hot air to rise around the product. This will result in uneven heating and increase the cooking time.

MAINTENANCE

Service

Shut off the main gas supply before attempting any maintenance on the unit. If required, contact your dealer, the factory, or a local service company to obtain qualified maintenance and repairs.

Care And Cleaning

- (A) The top grates should be cleaned using a stiff wire brush. If this is done daily, the accumulation of food and fat caught in the grates and work necessary to keep them clean will be reduced. Periodically, they should be turned over and brushed and then put back. In the event that an extra amount of fat is accumulated on the top, due to use of low heat, we recommend turning up the flame of this section for about an hour, which will burn off much of the fat and residue and the brushing operation will be easier. Under no circumstances should the grates be placed in a dishwasher. Soap, water, or any detergents should never be used on the cast iron grates.
- (B) Front - Sample supplied with the unit or any reputable stainless steel cleaner can be used.

- (C) Inner panels - These are made of aluminized steel. Use hot soapy water and soft nylon scrub pads to clean the surfaces.
- (D) Grease pan and grease collector - Grease pan and collector should be cleaned daily or more often if necessary.

! CAUTION

- (A) Clean the unit only when it is cold.
- (B) Always rub with the grains when cleaning.
- (C) Do not use abrasive pads for cleaning.
- (D) Do not use caustic cleaning compounds on aluminized surfaces.

Cleaning Tools

Several models of specially designed top grate brushes and grease drain scrapers are available from Bakers Pride. Contact Bakers Pride for more information.



XXE CHARBROILER OPERATION MANUAL

MAINTENANCE

Troubleshooting Chart

PROBLEM	PROBABLE CAUSE	SOLUTION
Burners & pilots will not turn on	Main gas supply to broiler is not turned on.	Turn on main gas supply.
Burners produce excessive carbon deposits	Incorrect gas type.	Supply correct type gas.
	Incorrect gas supply pressure.	Call local gas supplier.
	Incorrect orifices.	Call Bakers Pride authorized service center.
	Primary air not adjusted properly.	Adjust air shutter.
Pilot will not remain lit	Pilot flame adjusted incorrectly.	Adjust pilot flame.
	Draft condition.	Remove draft.
	Improper ventilation system.	Call an HVAC specialist.
	Debris or grease clogging pilot burner or thermocouple.	Clean debris & grease from pilot burner & thermocouple.
	Pilot safety valve or thermocouple has failed.	Replace failed component.
Excessive flare-up	Overload of fatty meat.	Add water to grease pan.
Broiler doesn't seem hot enough	Orifices may be dirty/clogged.	When unit cools, check & clean orifices.
	Low gas pressure.	Increase gas pressure to 5" W.C. (Nat) or 10" W.C. (L.P.)
	Top grates may be dirty/clogged.	When unit cools, check & clean top grates.
	If the ventilation is too strong it will suck heat from the cooking/broiling surface.	Call an HVAC specialist.
	Too many Glo-stones restricting heat to top grates.(Glo-stone models only).	Reduce the number of Glo-stones.
Grates &/or radiants &/or burners &/or gas valves warp	Usually improper cleaning methods ie; users cover grate top w/sheet pans & crank up heat to burn-off debris.	Do not "Burn-Off" top grates. This causes the firebox area to overheat excessively. *Never Cover top grates.

MANIFOLD & VALVE ASSEMBLY VIEWS

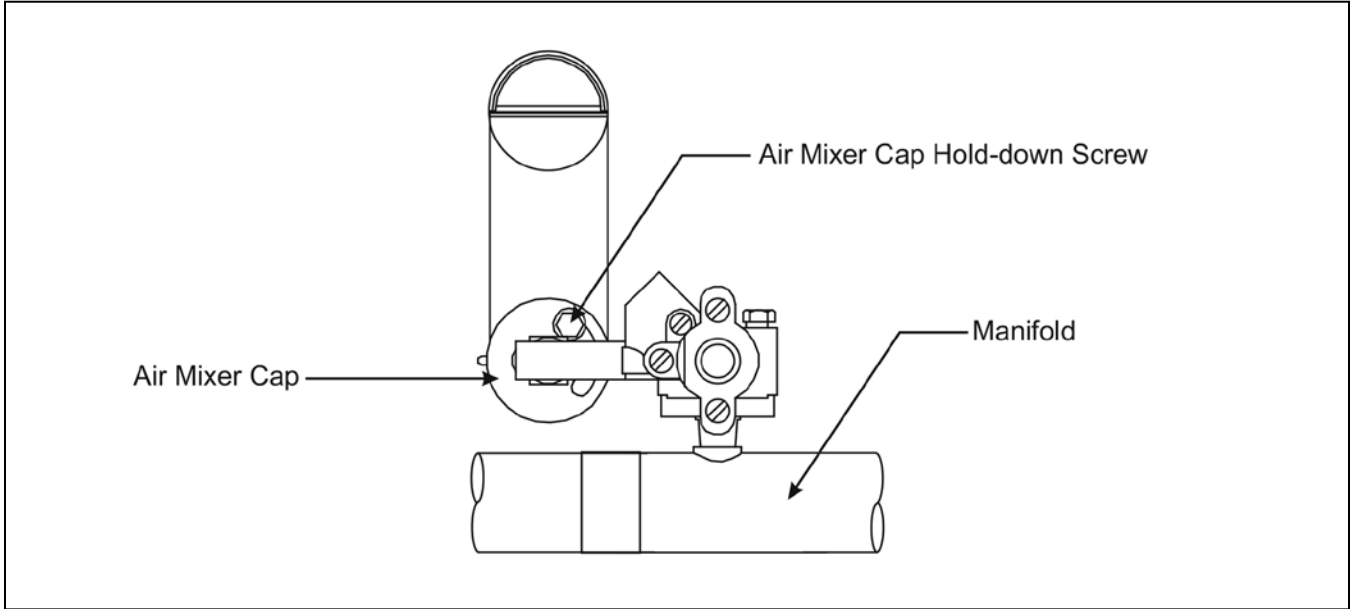

Figure 1: XXE Series - Front View

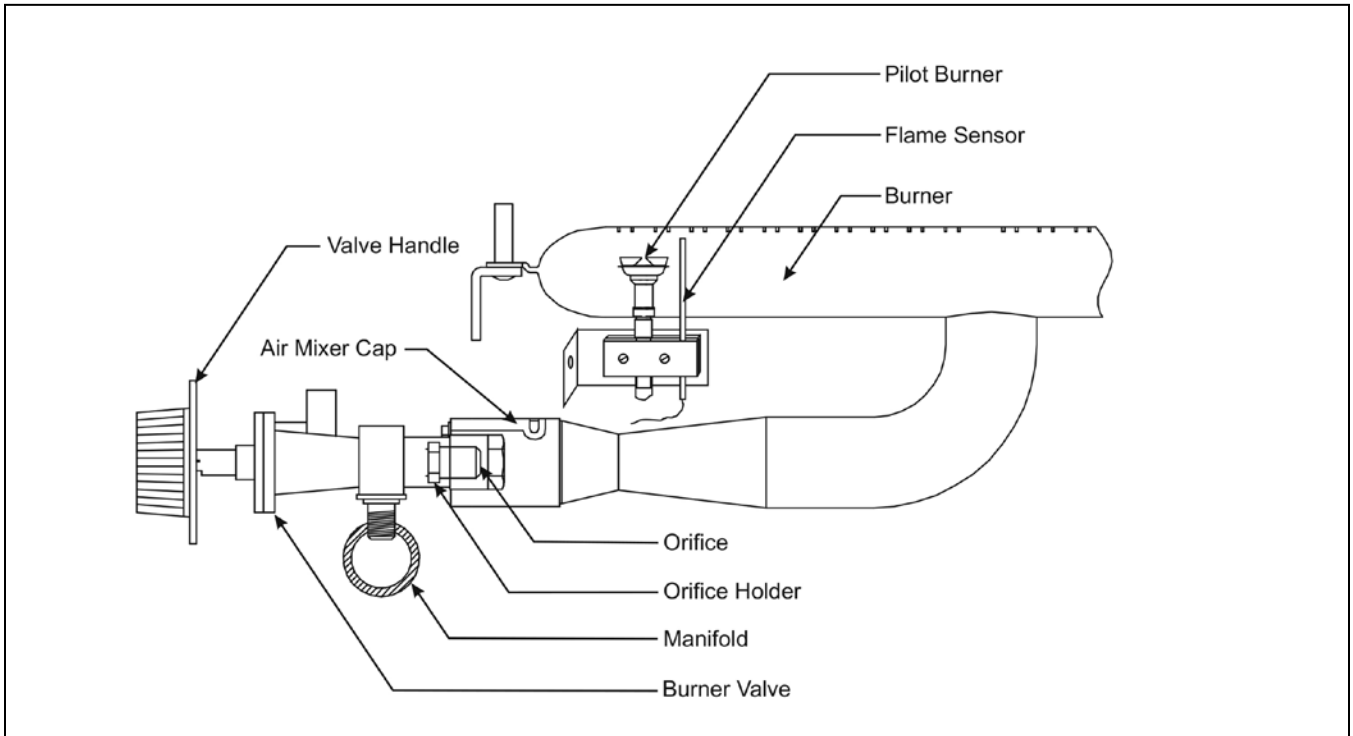

Figure 2: XXE Series - Side View

PARTS LISTS AND EXPLODED VIEWS

Dante Series



Model Number

- XXE-4
- XXE-6
- XXE-8
- XXE-10

Serial Number

Type of Gas

- Natural
- LP
- Other

Note: When ordering, ALWAYS specify Part #, Model #, Serial #, Voltage/Phase & type of Gas.

PARTS LISTS AND EXPLODED VIEWS

EXPLODED VIEW – XXE-4, 6, 8, 10, 12

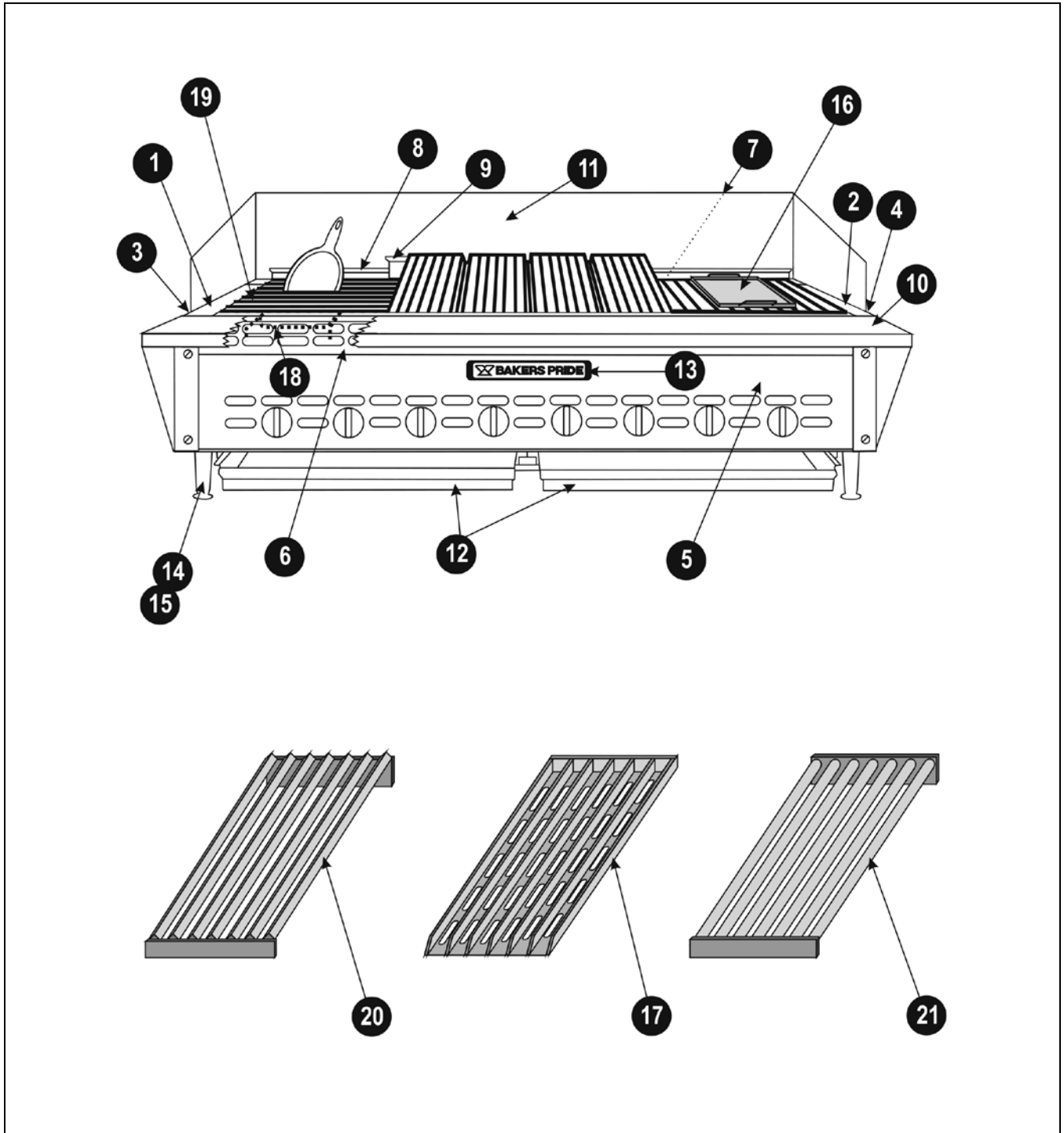

Note: When ordering, ALWAYS specify Part #, Model #, Serial #, Voltage/Phase and Gas Type.



PARTS LISTS AND EXPLODED VIEWS

Item	Part No.	Description
1	G1011K	Top Side Trim, SS, Left
2	G1012K	Top Side Trim, SS, Right
3	G1458K	Outer Side, Left (XXE)
4	G1459K	Outer Side, Right (XXE)
5	G1454K	Control Panel (XXE-4)
	G1455K	Control Panel (XXE-6)
	G1456K	Control Panel (XXE-8)
	G1457K	Control Panel (XXE-10)
6	G1474K	Top Front Trim (XXE-4)
	G1475K	Top Front Trim (XXE-6)
	G1476K	Top Front Trim (XXE-8)
	G1477K	Top Front Trim (XXE-10)
7	G1461K	Outer Back (XXE-4)
	G1462K	Outer Back (XXE-6)
	G1463K	Outer Back (XXE-8)
	G1464K	Outer Back (XXE-10)
8	G1021U	1st/2nd Level Assy (XX-4)
	G1022U	1st/2nd Level Assy (XX-6)
	G1023U	1st/2nd Level Assy (XX-8)
	G1024U	1st/2nd Level Assy (XX-10)
9	G1055K	3rd Level Bracket (XX-4) Optional
	G1056K	3rd Level Bracket (XX-6) Optional
	G1057K	3rd Level Bracket (XX-8) Optional
	G1058K	3rd Level Bracket (XX-10) Optional

Item	Part No.	Description
10		Work Deck, S/S (XXE-4) Optional
		Work Deck, S/S (XXE-6) Optional
		Work Deck, S/S (XXE-8) Optional
		Work Deck, S/S (XXE-10) Optional
11	G1081X	Splash Guard, S/S (XX-4) Optional
	G1082X	Splash Guard, S/S (XX-6) Optional
	G1083X	Splash Guard, S/S (XX-8) Optional
	G1084X	Splash Guard, S/S (XX-10) Optional
12	T3033K	Grease Pan (XX-4) 20 3/8", 1 used
	T3034K	Grease Pan (XX-6 or 10) 30 7/8", 1 used
	T3035K	Grease Pan (XX-8) 19 5/8", 2 used
	T1036T	Grease Pan (XX-10) 19 1/4", 1 used
13	U1043A	Name Plate, 13 1/4", Bakers Pride
14	S1394A	Leg, 4" Adjustable (Each)
15	S1394X	Leg, 4" Adjustable (Set/4)
16	T1020T	Griddle Plate (Optional) 16"
17	T1006A	Grate, Top, Flat Cast Iron (5 1/4")
18	T1183T	Grate, Fajita Bottom
19	T1185S	Grate, Fajita Top
20	T1172T	Grate, Meat 10 1/2"
21	T1166T	Grate, Fish 10 1/2"

Note: When ordering, ALWAYS specify Part #, Model #, Serial #, Voltage/Phase and Gas Type.

PARTS LISTS AND EXPLODED VIEWS

EXPLODED VIEW – XXE-4, 6, 8, 10, 12 Burner / Accessories

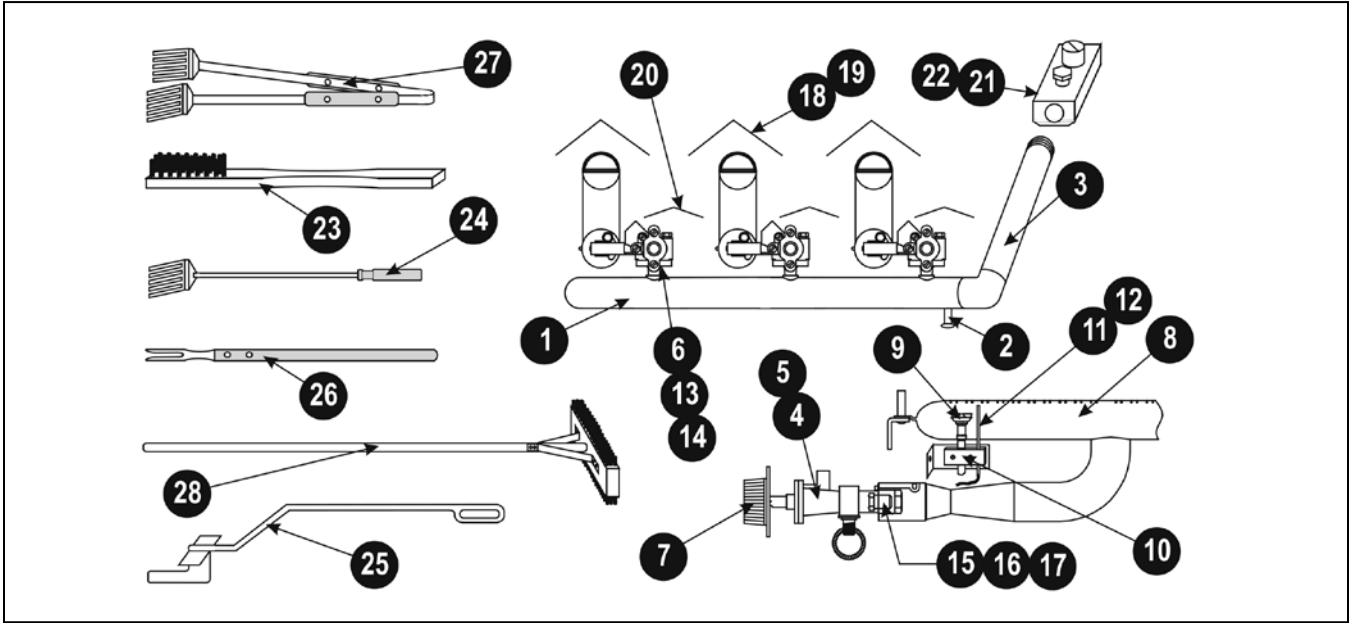

Item	Part No.	Description
1	R1085P	Manifold Assy (XXE-4)
	R1086P	Manifold Assy (XXE-6)
	R1087P	Manifold Assy (XXE-8)
	R1088P	Manifold Assy (XXE-10)
2	N3068P	Pressure Tap Nozzle Assy
3	N5217P	Gas Inlet Pipe (XX Series)
4	R3128A	Valve, Multi Gas Cock
5	M1053A	Valve, Junker (Old Style)
6	R3181P	Pilot Tubing, 5" (XXE)
7	S1301A	Knob, CE Broiler
8	L5078A	Burner, Center Feed (XXE)
9	M1359A	Pilot Burner
10	G1472K	Pilot Burner Mounting Bracket (XXE)
11	M1358A	Thermocouple, 10"
12	M1267X	Thermocouple (used w/O.S. Junker Valve)
13	N1007A	Compression Nut, 3/16", Female

Item	Part No.	Description
14	N1010A	Ferrule, 3/16"
15	R3130A	Orifice Hood #44, Nat (XXE)
16	R3044A	Orifice Hood #55, LP (XXE)
17	R3023A	Orifice Hood, Blank
18	T1155T	Radiant, S/S (23") Standard
19	T1007A	Radiant, Cast Iron (23") Optional
20	G1470K	Heat Shield (XXE-4 uses 5) (XXE-6 uses 7) (XXE-8 uses 9) (XXE-10 uses 11)
21	M1009A	Pressure Regulator, 3/4", 10" WC
22	M1184A	Pressure Regulator, 3/4", 3.5" WC
23	T5017A	Wire Brush, Chef-Aide, 18"
24	T5018U	Spatula, Chef-Aide, 20", Single
25	T5041T	Grate Lifter, 3' x 20"
26	T5016A	Meat Fork
27	T5019V	Steak Turner
28	T5104V	Twin Head Grate Brush

Conversion Kit (LP to NAT)	
R3130A	Hood Orifice #44, Nat, (XXE-4 uses 4) (XXE-6 uses 6) (XXE-8 uses 8) (XXE-10 uses 10)
M1184A	Pressure regulator 3/4", 3.5" WC (Qty 1)

Conversion Kit (NAT to LP)	
R3044A	Hood Orifice #55, LP, (XXE-4 uses 4) (XXE-6 uses 6) (XXE-8 uses 8) (XXE-10 uses 10)
M1009X	Pressure regulator 3/4", 10" WC (Qty 1)

Note: When ordering, ALWAYS specify Part #, Model #, Serial #, Voltage/Phase and Gas Type.



HEAVY DUTY GAS CHARBROILER OPERATION MANUAL

BAKERS PRIDE LIMITED WARRANTY

WHAT IS COVERED	<p>This warranty covers defects in material and workmanship under normal use, and applies only to the original purchaser providing that:</p> <ul style="list-style-type: none">• The equipment has not been accidentally or intentionally damaged, altered or misused;• The equipment is properly installed, adjusted, operated and maintained in accordance with National and local codes and in accordance with the installation instruction provided with the product;• The serial number rating plate affixed to the equipment has not been defaced or removed.
WHO IS COVERED	<p>This warranty is extended to the original purchaser and applies only to equipment purchased for use in the U.S.A.</p>
COVERAGE PERIOD	<p>Cyclone Convection Ovens: BCO Models: One (1) Year limited parts and labor; (1) Year limited door warranty. GDCO Models: Two (2) Year limited parts and labor; (2) Year limited door warranty. CO11 Models: Two (2) Year limited parts and labor; (5) Year limited door warranty. All Other Products: One (1) Year limited parts and labor. Warranty period begins the date of dealer invoice to customer or ninety (90) days after shipment date from Bakers Pride - whichever comes first.</p>
WARRANTY	<p>This warranty covers on-site labor, parts and reasonable travel time and travel expenses of the authorized service</p>
COVERAGE	<p>representative up to (100) miles, round trip, and (2) hours travel time. The purchaser, however, shall be responsible for all expenses related to travel, including time, mileage and shipping expenses on smaller counter models that may be carried into a Factory Authorized Service Center, including the following models: PX-14, PX-16, P18, P22S, P24S, PD-4, PDC, WS Series and BK-18.</p>
EXCEPTIONS	<p>All removable parts in Bakers Pride® Charbroilers, including but not limited to: Burners, Grates, Radiants, Stones and Valves, are covered for a period of SIX MONTHS. All Ceramic Baking Decks are covered for a period of THREE MONTHS. The installation of these replacement decks is the responsibility of the purchaser. The extended Cyclone door warranty years 3 through 5 is a parts only warranty and does not include labor, travel, mileage or any other charges.</p>
EXCLUSIONS	<ul style="list-style-type: none">• Negligence or acts of God,• Failures caused by erratic voltages or gas supplies,• Thermostat calibrations after (30) days from equipment installation date,• Unauthorized repair by anyone other than a Bakers Pride Factory Authorized Service Center,• Air and Gas adjustments,• Damage in shipment,• Light bulbs,• Alteration, misuse or improper installation,• Glass doors and door adjustments,• Thermostats and safety valves with broken capillary tubes,• Fuses,• Char-broiler work decks and cutting boards,• Tightening of conveyor chains,• Adjustments to burner flames and cleaning of pilot burners,• Tightening of screws or fasteners.• Accessories — spatulas, forks, steak turners, grate lifters, oven brushes, scrapers, peels. etc.,• Freight — other than normal UPS charges,• Ordinary wear and tear.
INSTALLATION	<p>Leveling and installation of decks as well as proper installation and check out of all new equipment —per appropriate installation and use materials — is the responsibility of the dealer or installer, not the manufacturer.</p>
REPLACEMENT PARTS	<p>Bakers Pride genuine Factory OEM parts receive a (90) day materials warranty effective from the date of installation by a Bakers Pride Factory Authorized Service Center.</p>

This Warranty is in lieu of all other warranties, expressed or implied, and all other obligations or liabilities on the manufacturer's part. Bakers Pride shall in no event be liable for any special, indirect or consequential damages, or in any event for damages in excess of the purchase price of the unit. The repair or replacement of proven defective parts shall constitute a fulfillment of all obligations under the terms of this warranty.

Standex

Food Service Equipment Group

The Standex Food Service Equipment Group (FSEG) is a manufacturer of innovative commercial food service equipment offering a wealth of refrigeration and cooking expertise. Products include walk-in coolers and freezers; hot and cold display cabinets, cases, and storage systems; commercial ovens, rotisseries, and cooking equipment; and rotary vane pumps.

Ask your sales representative about how the power of all Standex brands can work for you.
www.standex.com/segments/food-service



Be sure to keep up with new product announcements and events on social media!

