



## INSTALLATION AND OPERATING INSTRUCTIONS

### TOP MOUNT SOUP WELLS Models: SM-50-4, -4D, -7, -7D, -11, -11D



**INTENDED FOR OTHER THAN HOUSEHOLD USE**

**RETAIN THIS MANUAL FOR FUTURE REFERENCE**



**WARNING:** Improper installation, adjustment, alteration, service or maintenance can cause property damage, injury or death. Read the Installation, Operating and Maintenance Instructions thoroughly before installing or servicing this equipment.



This equipment has been engineered to provide you with year-round dependable service when used according to the instructions in this manual and standard commercial kitchen practices.

Phone: +1 (214) 421-7366  
Fax: +1 (214) 565-0976  
Toll Free: +1 (800) 527-2100  
Website: [www.apwwyott.com](http://www.apwwyott.com)  
E-mail: [info@apwwyott.com](mailto:info@apwwyott.com)

P/N 79900399 9/06

**APW WYOTT**  
729 Third Avenue  
Dallas, TX 75226

# TABLE OF CONTENTS

Safety Precautions.....	2
General Information.....	4
General Troubleshooting.....	4
Installation.....	4
Dimensions & Shipping Weights.....	5
Electrical Specifications.....	5
Option Specifications.....	5
Operation & Cleaning.....	5
Parts List w/Exploded View.....	6
Wiring Diagrams.....	7
Warranty.....	8

## IMMEDIATELY INSPECT FOR SHIPPING DAMAGE

All containers should be examined for damage before and during unloading. The freight carrier has assumed responsibility for its safe transit and delivery. If equipment is received damaged, either apparent or concealed, a claim must be made with the delivering carrier.

A) Apparent damage or loss must be noted on the freight bill at the time of delivery. It must then be signed by the carrier representative (Driver). If this is not done, the carrier may refuse the claim. The carrier can supply the necessary forms.

B) Concealed damage or loss if not apparent until after equipment is uncrated, a request for inspection must be made to the carrier within 15 days. The carrier should arrange an inspection. Be certain to hold all contents and packaging material.

Installation and start-up should be performed by a qualified installer who thoroughly read, understands and follows these instructions.

**APW Wyott** takes pride in the design and quality of our products. When used as intended and with proper care and maintenance, you will experience years of reliable operation from this equipment. To ensure best results, it is important that you read and follow the instructions in this manual carefully.



Installation and start-up should be performed by a qualified installer who thoroughly read, understands and follows these instruction.



If you have questions concerning the installation, operation, maintenance or service of this product, write Technical Service Department: APW/Wyott Foodservice Equipment Company, 729 Third Avenue, Dallas, TX 75226.



## SAFETY PRECAUTIONS



Before installing and operating this equipment be sure everyone involved in its operation are fully trained and are aware of all precautions. Accidents and problems can result by a failure to follow fundamental rules and precautions.

The following words and symbols, found in this manual, alert you to hazards to the operator, service personnel or the equipment. The words are defined as follows:

 **DANGER:** This symbol warns of imminent hazard which will result in serious injury or death. 

 **WARNING:** This symbol refers to a potential hazard or unsafe practice, which could result in serious injury or death. 

 **CAUTION:** This symbol refers to a potential hazard or unsafe practice, which may result in minor or moderate injury or product or property damage. 

 **NOTICE:** This symbol refers to information that needs special attention or must be fully understood even though not dangerous. 

## THIS MANUAL SHOULD BE RETAINED FOR FUTURE REFERENCE



**CAUTION:** These models are designed, built, and sold for commercial use. If these models are positioned so the general public can use the equipment make sure that cautions, warnings, and operating instructions are clearly posted near each unit so that anyone using the equipment will use it correctly and not injure themselves or harm the equipment.



**WARNING:** Check the data plate on this unit before installation. Connect the unit only to the voltage and frequency listed on the data plate. Connect only to 1 or 3 phase as listed on the data plate.



**WARNING:** In Europe, appliance must be connected by an earthing cable to all other units in the complete installation and thence to an independent earth connection in compliance with EN 60335-1 and/or local codes



**WARNING:** For your safety do not store or use gasoline or other flammable vapors or liquids in the vicinity of this or any other appliance. Keep the area free and clear of combustibles. (See ANZI Z83.14B, 1991)



**NOTICE:** This equipment has been engineered to provide you with year round dependable service when used according to the instructions in this manual and standard commercial kitchen practices.



**WARNING:** Install per the spacing requirements listed in the installation section of this manual. We strongly recommend having a competent professional install the equipment. A licensed electrician should make the electrical connections and connect power to the unit. Local codes should always be used when connecting these units to electrical power. In the absence of local codes, use the latest version of the National Electrical Code.



**WARNING:** This device should be safely and adequately grounded in accordance with local codes, or in the absence of local codes, with the National Electrical code, ANSI/NFPA 70, Latest Edition to protect the user from electrical shock. It requires a grounded system and a dedicated circuit, protected by a fuse or circuit breaker of proper size and rating. Canadian installation must comply with the Canadian Electrical Code, CSA C22.2, as applicable



**WARNING:** An earthing cable must connect the appliance to all other units in the complete installation and from there to an independent earth connection.



**NOTICE:** Local codes regarding installation vary greatly from one area to another. The National Fire Protection Association, Inc. states in its NFPA96 latest edition that local codes are "Authority Having Jurisdiction" when it comes to requirement for installation of equipment. Therefore, installation should comply with all local codes.



**WARNING:** Unit is not waterproof. Do not submerge in water. Do not operate if it has been submerged in water. Do not clean the unit with a water jet.



## IMPORTANT FOR FUTURE REFERENCE

Please complete this information and retain this manual for the life of the equipment. For Warranty Service and/or Parts, this information is required.

\_\_\_\_\_

Model Number

\_\_\_\_\_

Serial Number

\_\_\_\_\_

Date Purchased

## GENERAL INFORMATION

### General Installation:

1. Always clean equipment thoroughly before first use. (See general cleaning instructions.)
2. Check rating label for your model designation & electrical rating.
3. For best results, use stainless steel countertops.
4. All dimensions in parenthesis in centimeters, unless noted.

### General Operating Instructions:

1. All food service equipment should be operated by trained personnel.
2. Do not allow your customers to come in contact with any surface labeled "CAUTION HOT."
3. Where applicable: Never pour cold water into dry heated units.
4. Where applicable, do not cook, warm or hold food directly in liner pans (well pans). Always use steam table pans/insets, etc.
5. Never hold food below 150°F (66°C)

### Wet set-up and operation procedures:

1. Add hot water 120°-140°F (50°-60°C) to well pan:
  - 4 Quart Round use 2 cups (½ litre)
  - 7 Quart Round use 3 cups (0.7 litre)
  - 11 Quart Round use 5 cups (1.4 litre)
2. Turn thermostat control to "10" setting or if equipped with infinite control to "7" or "High". Preheat for approximately 30 minutes.
3. Place covered inset with preheated product into well.
4. Re-adjust control after another 30 minutes of operation to acquire desired temperature depending on the amount and thickness of product.
5. Keep inset/steamtable pan(s) covered to maintain ideal serving temperature.
6. **Do not let well run dry.**

### General Cleaning Instructions:

1. NEVER clean any electrical unit by immersing it in water. Turn off before surface cleaning.
2. Always clean equipment thoroughly before first use. Clean unit daily. Use warm, soapy water (except where noted on charts). Mild cleansers and PLASTIC scouring pads may be used to remove baked-on food and water scale.
3. Turn off electrical units before cleaning or servicing. All service should be performed by an APW Wyott authorized service agency.

## GENERAL TROUBLESHOOTING

- Always Ask & Check:**
1. Is the unit connected to a live power source?
  2. Check circuit breaker.
  3. Is power switch on & pilot light glowing?
  4. Check rating label. Are you operating unit on proper voltage?

## INSTALLATION

1. Follow General Installation Instructions on page 3 (above).
2. Make applicable Cut-Out per below table. Note: Unit is designed for installation in stainless steel tops.
3. Apply putty tape to underside perimeter of the well rim outer edge.
4. Apply a 1/4" (.6) bead of silicone sealant adjacent to the putty tape on the well flange.
5. Drop well into opening from the top and push down until entire perimeter of rim is flush with the counter surface.
6. From below the counter surface insert an #8 to #10 (20 to 25 cm) flat tip screwdriver into the locking ring tab slots and twist in a clockwise motion to lock well in place.
7. Trim excess putty and sealant from around well rim.

8. Mount control to front panel using hardware. Maintain 4" (10.2) clearance between well and front panel.
9. Check nameplate for proper voltage. Connect power.
10. Maintain 4" clearance around all soup wells.

**Note:** Electrically connect units to comply with local and NEC codes.

## GENERAL SPECIFICATIONS (4 QT., 7 QT. AND 11 QT.)

Model	Outside Dimensions	Inside Dimensions	Cut Out	Flange	Standard Control	Control Cut Out	Shipping Weight
	Dia. X Dia.	Dia. X Dia.	Dia				
4 Qt (3.8L)	8 25/64 x 8 1/8 (21.2 x 20.6)	6 25/64 x 6 1/2 (16.2 x 15.5)	6 3/4 (17.1)	1 (2.5)	Thermostat has 36" (91.4) capillary effective length 26" (66.0)	Use Control Plate for hole pattern	9 Lbs. (22.9)
7 Qt (6.6L)	10 1/2 x 8 1/8 (26.7 x 20.6)	8 9/32 x 6 1/2 (21.0 x 15.5)	8 3/4 (22.2)	1 (2.5)	Thermostat has 36" (91.4) capillary effective length 26" (66.0)	Use Control Plate for hole pattern	11 Lbs. (27.9)
11 Qt (10.4L)	12 1/2 x 8 1/8 (31.8 x 20.6)	10 9/32 x 6 1/2 (26.1 x 15.5)	10 3/4 (27.3)	1 (2.5)	Thermostat has 36" (91.4) capillary effective length 26" (66.0)	Use Control Plate for hole pattern	12 Lbs. (30.5)

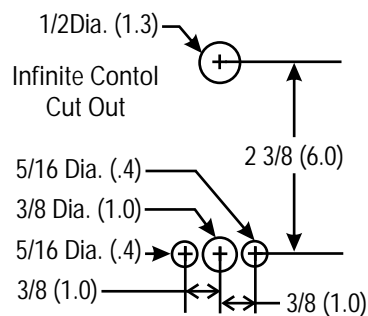
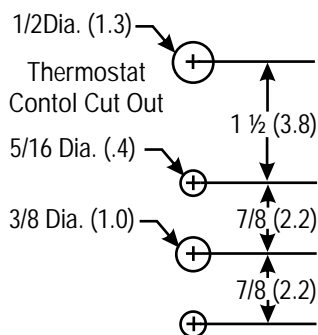
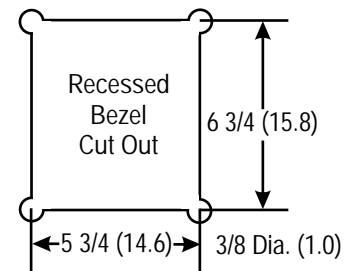
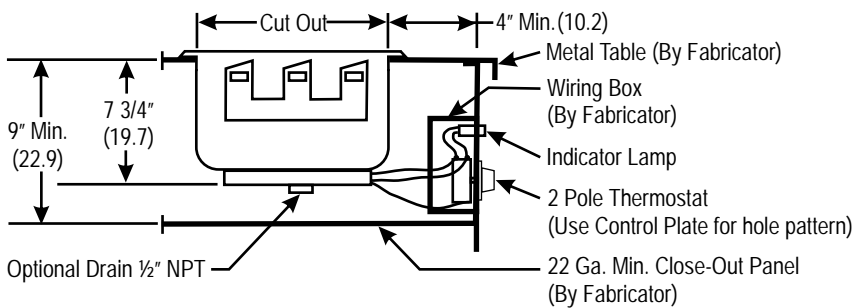

## ELECTRICAL SPECIFICATIONS

Model Numbers	Volts	Watts	Amps (1 Phase)
SM-50-4	120V	400W	3.33A
	240V	400W	1.67A
SM-50-7 & SM-50-11	120V	500W	4.17A
	208/240V	500/660W	2.40/2.75A

## OPTION SPECIFICATIONS

Drain Standard w/Model No.'s	Drain Location	Drain Coupling	Thermostat	Recessed Bezel	Wood Mounting Kit, Stock No.'s	Wood Mounting Kit, Cut Out	Electrical Code Kit
SM-50-4 SM-50-7 SM-50-11 Add "D" for Drain	Center of Pot	1/2 NPT Stainless 1 1/2 (3.8) Long	With 72" (182.9) Capillary Effective Length 62" (157.5) Add (-72) to Model No.'s	Stock No.'s 56370 This is only the Recessed Bezel	4 Qt. 55286	8 13/16 x 8 13/16 (22.4 x 22.4)	Add (UL) to Stock No.'s
					7 Qt. 55333	10 13/16 x 10 13/16 (27.5 x 27.5)	
					11 Qt. 55323	12 13/16 x 12 13/16 (32.5 x 32.5)	

## OPERATION & CLEANING

1. Follow General Operating & General Cleaning Instructions on page 4.

# TOP MOUNT SOUP WELLS - PARTS LIST & EXPLODED VIEW

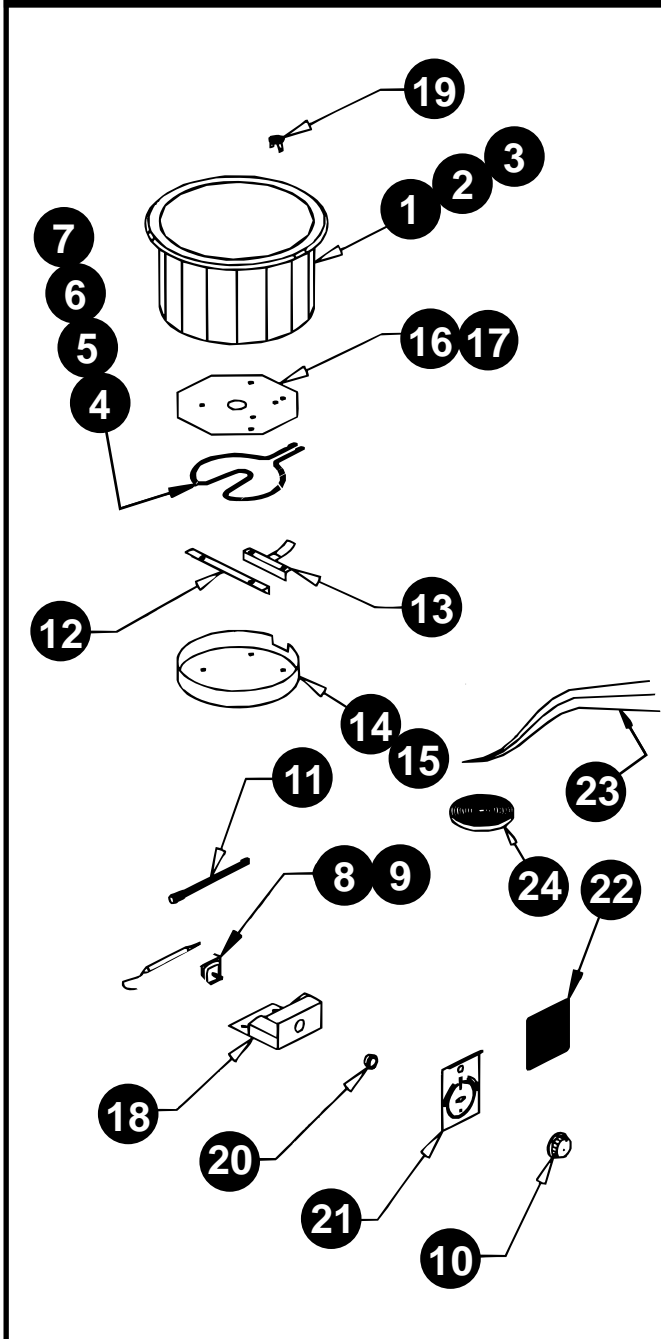

Item	P/N	Description
1	56675	4 Qt. Well Pan No Drain
	56660	4 Qt. Well Pan W/Drain
2	56587	7 Qt. Well Pan No Drain
	56588	7 Qt. Well Pan W/Drain
3	56589	11 Qt. Well Pan No Drain
	56590	11 Qt. Well Pan W/Drain
4	54065	Heating Element 120V-400W (4 Qt)
5	55959	Heating Element 120V-500W
6	55960	Heating Element 120V-800W
7	55964	Heating Element 208/240V-500/660W
8	55564-EGO	Infinite Control, 120V
	87053-EGO	Infinite Control, 240V
9	56527	Thermostat, 36" Capillary
	56540	Thermostat, 72" Capillary
10	56505	Knob, Thermostat
	55825	Knob, Infinite Control
11	56530	Indicator Light
12	56673	Element Clamp (4 Qt)
	55695	Element Clamp (7 & 11 Qt)
13	56674	Anti-rotation Clamp (4 Qt)
	55696	Anti-rotation Clamp (7 & 11 Qt)
14	55976	Bottom Cover (4 Qt)
15	55992	Bottom Cover (7 & 11 Qt)
16	56672	Heat Transfer Plate (4 Qt)
17	50817	Heat Transfer Plate (7 & 11 Qt)
18	51026	Terminal Cover (7 & 11 Qt)
	51012	Terminal Cover (4 Qt)
19	56655	Drain Strainer
20	89184	Hole Bushing
21	56529	Increase/Decrease Plate T-Stat
	56562	Increase/Decrease Plate I/C
22	56542	Dial Setting Plate
23	55254	Wire Set/36", I/C
	55255	Wire Set/72", I/C
	56566	Wire Set/36", T-Stat
	56556	Wire Set/72", T-Stat
24	55869	Perma Gum Package
25	56370	Control Housing
	55055	Control Housing (CE)
26	56581	Conduit Box
	55057	Conduit Box (CE)
27	56586	Conduit Box Cover
	55065	Conduit Box Cover (CE)
28	55341	Flex Conduit/36" T-Stat
29	55331	Flex Conduit/72" T-Stat
30	55340	Anti-short Bushing
31	55339	Conduit Connector
32	55343	Conduit Connector 90°
33	30201	Terminal Block (CE)

## UL KIT

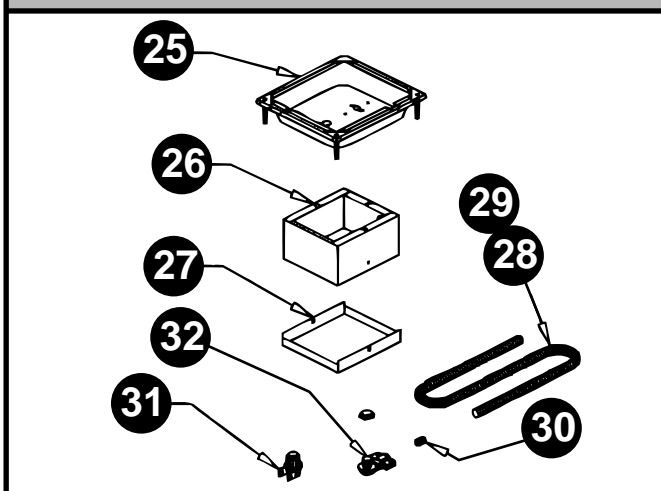

## Parts Not Shown

	88961	10-24 Green Hex Nut
	89061	10-24 Hex Nut
	89025	10-24 Speed Nut
	89071	#10 Flat Washer
	89059	#10 External Lockwasher
	89073	#8 X 1/2" Sheet Metal Screw
	89120	Jiffy Clip
	69106	Thermostat, Limiting 345°F

## SM-50 WIRING DIAGRAMS (DOMESTIC)

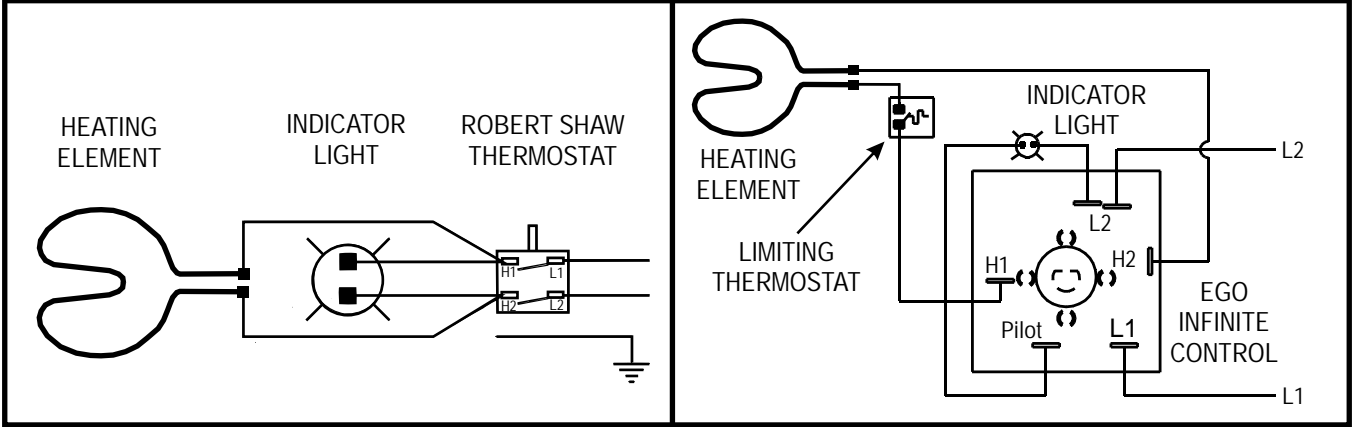

## SM-50 WIRING DIAGRAMS (CE)

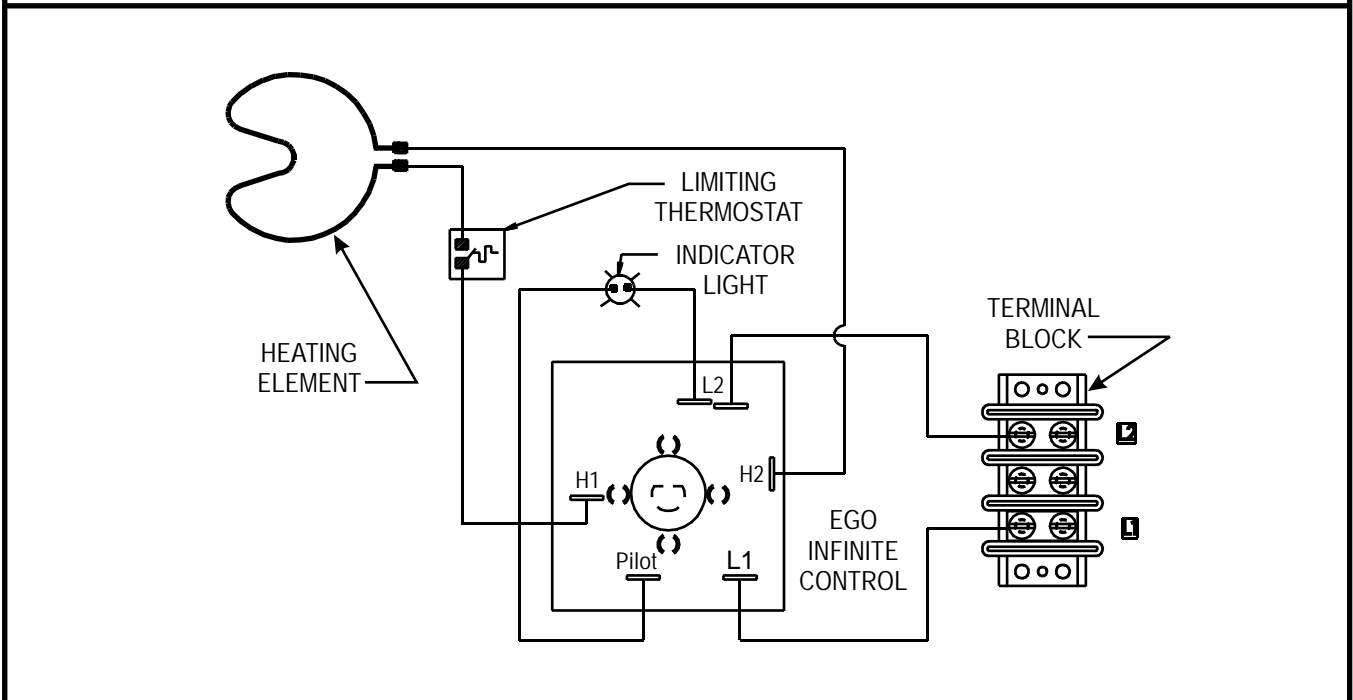
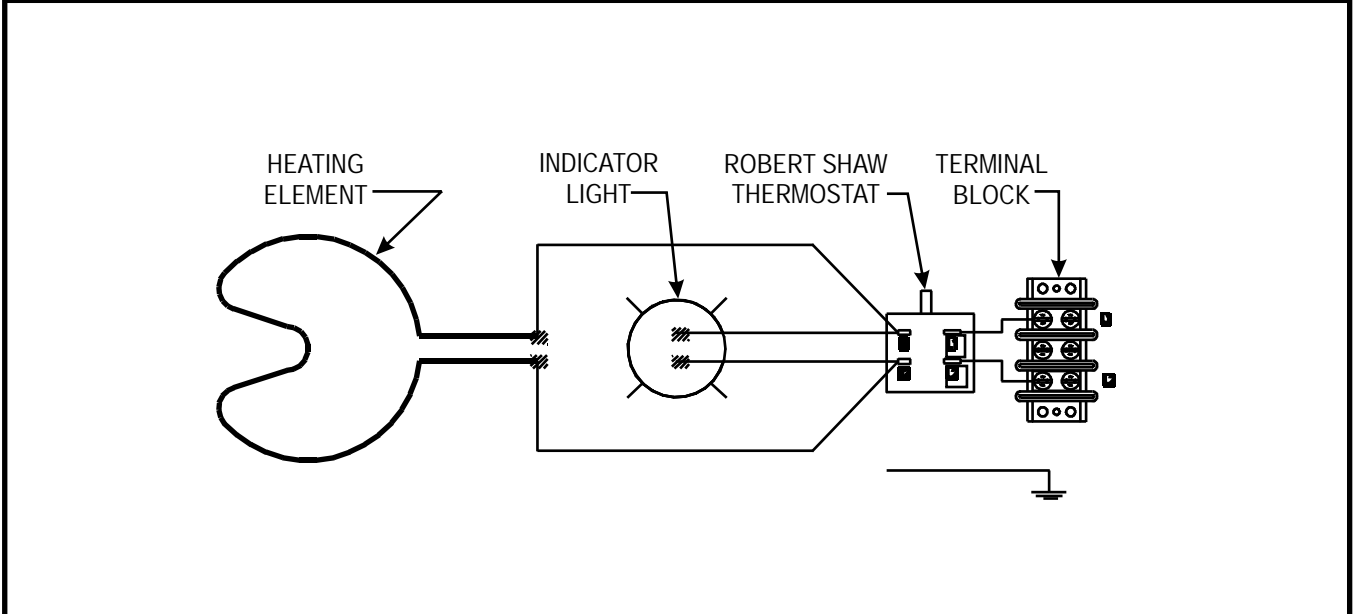

## APW WYOTT EQUIPMENT LIMITED WARRANTY

APW Wyott Foodservice Equipment Company warrants its equipment against defects in materials and workmanship, subject to the following conditions:

This warranty applies to the original owner only and is not assignable.

Should any product fail to function in its intended manner under normal use within the limits defined in this warranty, at the option of APW Wyott such product will be repaired or replaced by APW Wyott or its Authorized Service Agency. APW Wyott will only be responsible for charges incurred or service performed by its Authorized Service Agencies. The use of other than APW Wyott Authorized Service Agencies will void this warranty and APW Wyott will not be responsible for such work or any charges associated with same. The closest APW Wyott Authorized Service Agent must be used.

This warranty covers products shipped into the 48 contiguous United States, Hawaii, metropolitan areas of Alaska and Canada. There will be no labor coverage for equipment located on any island not connected by roadway to the mainland.

Warranty coverage on products used outside the 48 contiguous United States, Hawaii, and metropolitan areas of Alaska and Canada may vary. Contact the international APW Wyott distributor, dealer, or service agency for details.

### Time Period

One year for parts and one year for labor, effective from the date of purchase by the original owner. The Authorized Service Agency may, at their option, require proof of purchase. Parts replaced under this warranty are warranted for the un-expired portion of the original product warranty only.

### Exceptions

- \***Gas/Electric Cookline:** Models GCB, GCRB, GF, GGM, GGT, CHP-H, EF, EG, EHP. Three (3) Year Warranty on all component parts, except switches and thermostats. (2 additional years on parts only. No labor on second or third year.)
- \***Broiler Briquettes, Rock Grates, Cooking Grates, Burner Shields, Fireboxes:** 90 Day Material Only. No Labor.
- \***Heat Strips:** Models FD, FDL, FDD, FDDL. Two (2) Year Warranty on element only. No labor second year.
- \***Glass Windows, Doors, Seals, Rubber Seals, Light Bulbs:** 90 Day Material Only. No Labor.

In all cases, parts covered by extended warranty will be shipped FOB the factory after the first year.

### Portable Carry In Products

Equipment weighing over 70 pounds or permanently installed will be serviced on-site as per the terms of this warranty. Equipment weighing 70 pounds or under, and which is not permanently installed, i.e. with cord and plug, is considered portable and is subject to the following warranty handling limitations. If portable equipment fails to operate in its intended manner on the first day of connection, or use, at APW Wyott's option or its Authorized Service Agency, it will be serviced on site or replaced.

From day two through the conclusion of this warranty period, portable units must be taken to or sent prepaid to the APW Wyott Authorized Service Agency for in-warranty repairs. No mileage or travel charges are allowed on portable units after the first day of use. If the customer wants on-site service, they may receive same by paying the travel and mileage charges. Exceptions to this rule: (1) countertop warmers and cookers, which are covered under the Enhanced Warranty Program, and (2) toasters or rollergrills which have in store service.

### Exclusions

The following conditions are not covered by warranty:

- \*Equipment failure relating to improper installation, improper utility connection or supply and problems due to ventilation.
- \*Equipment that has not been properly maintained, calibration of controls, adjustments, damage from improper cleaning and water damage to controls.
- \*Equipment that has not been used in an appropriate manner, or has been subject to misuse or misapplication, neglect, abuse, accident, alteration, negligence, damage during transit, delivery or installation, fire, flood, riot or act of god.
- \*Equipment that has the model number or serial number removed or altered.

If the equipment has been changed, altered, modified or repaired by other than an Authorized Service Agency during or after the warranty period, then the manufacturer shall not be liable for any damages to any person or to any property, which may result from the use of the equipment thereafter.

This warranty does not cover services performed at overtime or premium labor rates. Should service be required at times which normally involve overtime or premium labor rates, the owner shall be charged for the difference between normal service rates and such premium rates. APW Wyott does not assume any liability for extended delays in replacing or repairing any items beyond its control.

In all cases, the use of other than APW Wyott Authorized OEM Replacement Parts will void this warranty.

This equipment is intended for commercial use only. Warranty is void if equipment is installed in other than commercial application.

### Water Quality Requirements

Water supply intended for a unit that has in excess of 3.0 grains of hardness per gallon (GPG) must be treated or softened before being used. Water containing over 3.0 GPG will decrease the efficiency and reduce the operation life of the unit.

**Note: Product failure caused by liming or sediment buildup is not covered under warranty.**

**“THE FOREGOING WARRANTY IS IN LIEU OF ANY AND ALL OTHER WARRANTIES EXPRESSED OR IMPLIED INCLUDING ANY IMPLIED WARRANTY OF MERCHANTABILITY OR FITNESS FOR PARTICULAR PURPOSES AND CONSTITUTES THE ENTIRE LIABILITY OF APW WYOTT. IN NO EVENT DOES THE LIMITED WARRANTY EXTEND BEYOND THE TERMS STATED HEREIN.”**

9/05