

ILLUS #	Part description	HF1-1S	HF2-1S	HF3-5S
1	DOOR ASSEMBLY, RH	40B32S718D	40B32S718D	40B32S718D
2	DOOR ASSEMBLY, LH	N/A	40B48S025D-02	40B48S025D-02
3	DOOR GASKET	712-012D-02	712-012D-02	712-012D-02
4	HINGE, DOOR, ASSY, LIFT OFF, (2 EA DR)	401-657B	401-657B	401-657B
5	HANDLE, ALUMINUM ANTIMICROBIAL	401-824D	401-824D	401-824D
6A	LOCK, WITH KEYS	401-510A	401-510A	401-510A
6B	KEYS, WITHOUT LOCK - FOR 401-510A	401-822B	401-822B	401-822B
6C	KEY, LOCK CORE REMOVAL	401-650A	401-650A	401-650A
7	LOCK STRIKE	401-604B	401-604B	401-604B
8	GRILL ASSEMBLY - SS	44B31-312D-01	44B31-312D-05	44B31-312D-07
9A	SEAL, VENT	09-2502-00	09-2502-01	09-2502-02
9B	VENT PLUG	10-0877-00	10-0877-01	10-0877-02
9C	CLIP, VENT	10-0879-00	10-0879-01	10-0879-02
9D	TUBE - VENT, PRESSURE RELIEF	205-192D-01	205-192D-01	205-192D-01
10	SWITCH, ROCKER - GOLD	502-434D	502-434D	502-434D
11	STRIKE - DOOR SWITCH,	710-004A	710-004A	710-004A
12A	5IN CASTER KIT EF/ER (2 W/LOCK & 2 NON-LOCK)	61C01-001A	61C01-001A	61C01-001A
12B	CASTER 5, NONLOCK, 1/2-13 STEM (EACH)	401-275A	401-275A	401-275A
12C	CASTER 5, W/LOCK, 1/2-13 STEM (EACH)	401-276A	401-276A	401-276A
13	INSTRUMENT PANEL ASSY. - SS (includes parts) CONTROLLER -DIXEL ELECTRONIC (TEMP	50B36S119D-05	50B36-120D-05	50B36-120D-07
14A	CONTROLLER)	502-431D-03	502-431D-03	502-431D-03
14B	HARNESS, SENSOR (for Dixel Controller)	515-123D	515-123D	515-166D
15	SWITCH, KILL, ROCKER	502-433D	502-433D	502-433D
16A	LIGHT SOCKET (RECEPTACLE)	503-244B	503-244B	503-244B
16B	LAMP, (INC) 40 WATTS, 40T10	503-071A	503-071A	503-071A
17	PILASTER 56"	401-273A	401-273A	401-273A
18	SUPPORT - SHELF	403-168A	403-168A	403-168A
19A	SHELF - WIRE	403-889D-01	403-887D-01	403-887D-01
19B	SHELF - WIRE - CENTER	N/A	N/A	403-893D-01
20	LID ASSY - EVAP HSG H1W	52B31S057D-01	52B31S057D-03	52B31S057D-04
21	REFRIGERATION SYSTEM COMPLETE	49B36S503D-01	49B36-504D-01	49B36-509D-01
22	CONDENSING UNIT ASSEMBLY	49B34S414D-01	49B34-415D-01	49B34-420D-01
23	CONDENSER COIL	305-156C	305-446D	305-162C
24	COMPRESSOR	312-082D (1/2HP 115-60 TEC AKA2425ZXA)	312-081D (3/4HP 115-60 TEC AJB2433ZXA)	312-087D (1HP, 220-60, TEC, AWA2450ZXD)
25	RELAY, COMPRESSOR START	314-045D	314-033A	314-046D
26	CAPACITOR, START	315-039D	315-030A	315-040D
27	CAPACITOR, RUN	316-009D	316-006A	316-010D

28	OVERLOAD PROTECTOR	313-040D	313-032A	N/A (compressor has internal OL protection)
29	COND MOTOR	501-148B (9 WATTS 115-60 GE) 405-050A, (7.94" 5 PET	501-158B-01 (16W 115V GE)	501-043B (9 W, 208-60)
30	CONDENSER FAN BLADE	ALUM)	19-0101-00 (9.5 ")	405-066B (10" 5Ped)
31	BRACKET - MOTOR MOUNT, LARGE	408-004A	408-004A	408-004A
32A	CONDENSATE PAN ASSEMBLY.	43B35S067D	43B35-068D-01	43B35-070D
32B	DISCHARGE TUBE (in condensate pan assy)	49A30-651D	49A30-661D	49A30-684D
33	EVAPORATOR COIL ASSEMBLY	49B31S342D-01	49B31-345D-01	49B31-348D-01
34	EVAP COIL	305-177C (9X7-9/32X6)	305-128C (21X7-9/32X6)	305-163C (35X7-9/32X6)
35	ACCUMULATOR	303-074A	303-182D	303-182D 303-184D (EFSE-1-ZP, 19PSI
36	EXP VALVE	303-183D	303-186D	504-520B (115V)
37A	HEATER - DEFROST 115V EF24	504-516B	504-517B	401-595B
37B	RETAINER - DEFROST HEATER	401-595B	401-595B	42B31-276D-01
38A	BLOWER ASSEMBLY, 115/60	42B31-272D-04	42B31-275D-01	42B30-269D-01
38B	BLOWER HSG. ONLY	42B30-266D-01	42B30-268D-01	501-175D
39	EVAP FAN MOTOR, 9 WATTS, 115/60, GE	501-175D	501-175D	405-033A
40	EVAP FAN BLADE, 8" (5 PED)	405-033A	405-033A	42A37-015B
41A	BRACKET, EVAP FAN MOTOR MOUNTING	42A37-015B	42A37-015B	603-338A
41B	SCREW - GE MOTOR MOUNTING	603-479A	603-338A	N/A
41C	WASHER - GE MOTOR MOUNTING	603-480A	N/A	N/A
41D	NUT - GE MOTOR MOUNTING	603-481A	N/A	N/A
42A	EVAP DRAIN PAN ASSEMBLY	43B32-232B	43B32-235B	43B32-236B
42B	EVAP DRAIN PAN - ONLY	43B32-229B	43B32-230B	43B32-231B
42C	SPRING, 0.25 X 1.27, EVAP DRAIN PAN MOUNT	404-414A	404-414A	404-414A
42D	SPRING HOOK, EVAP DRAIN PAN MOUNT	404-479A	404-479A	404-479A
43	HEATER, DRAIN TUBE, 115 V	504-539B	504-539B	504-539B

H MODELS ILLUSTRATIONS - (Representative only, actual parts may vary in appearance)

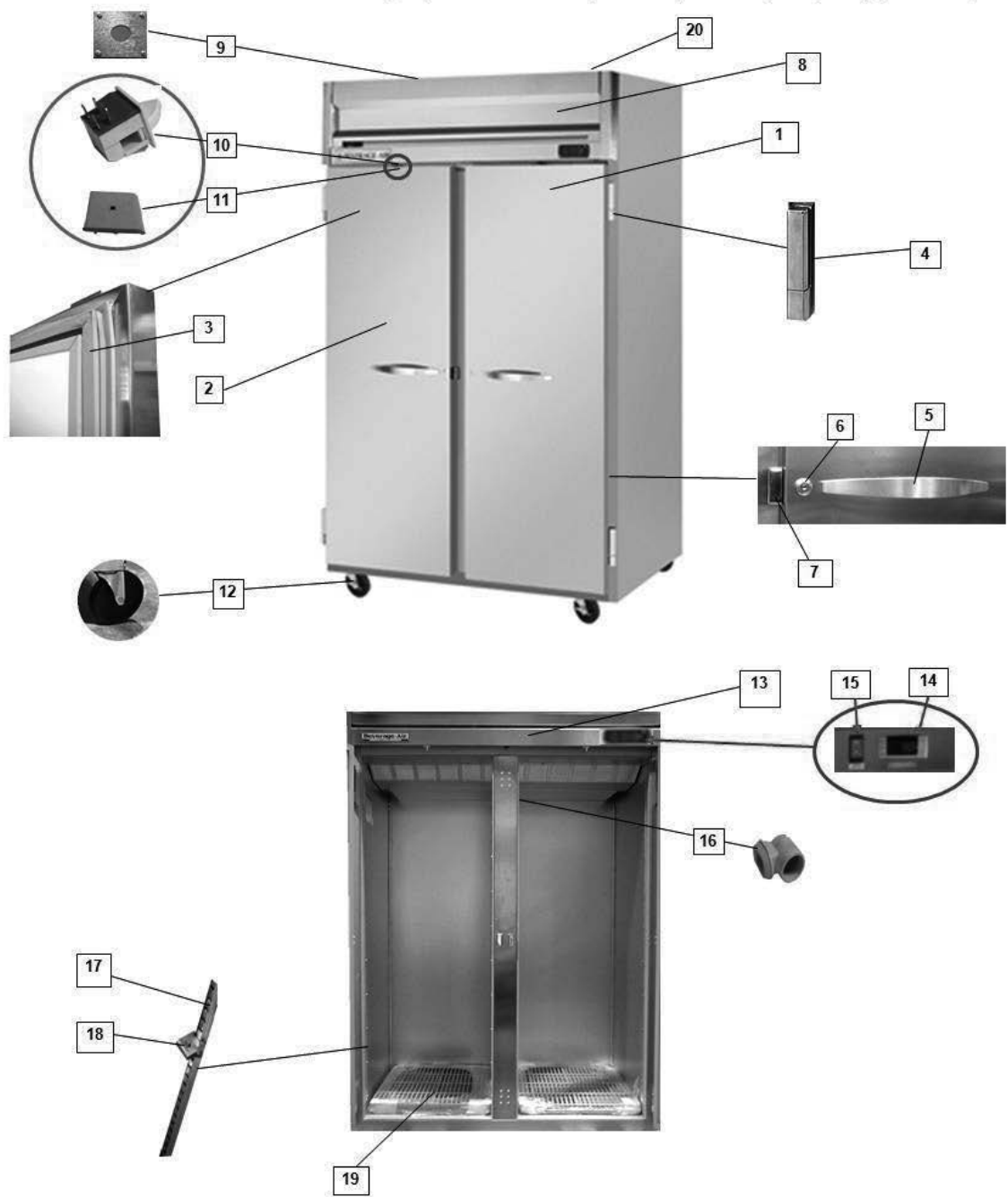

COMPLETE LIFT-OUT REFRIGERATION SYSTEM 21

Note: Compressor shown is semihermetic type. Actual compressor in unit may be semihermetic or fully hermetic type.

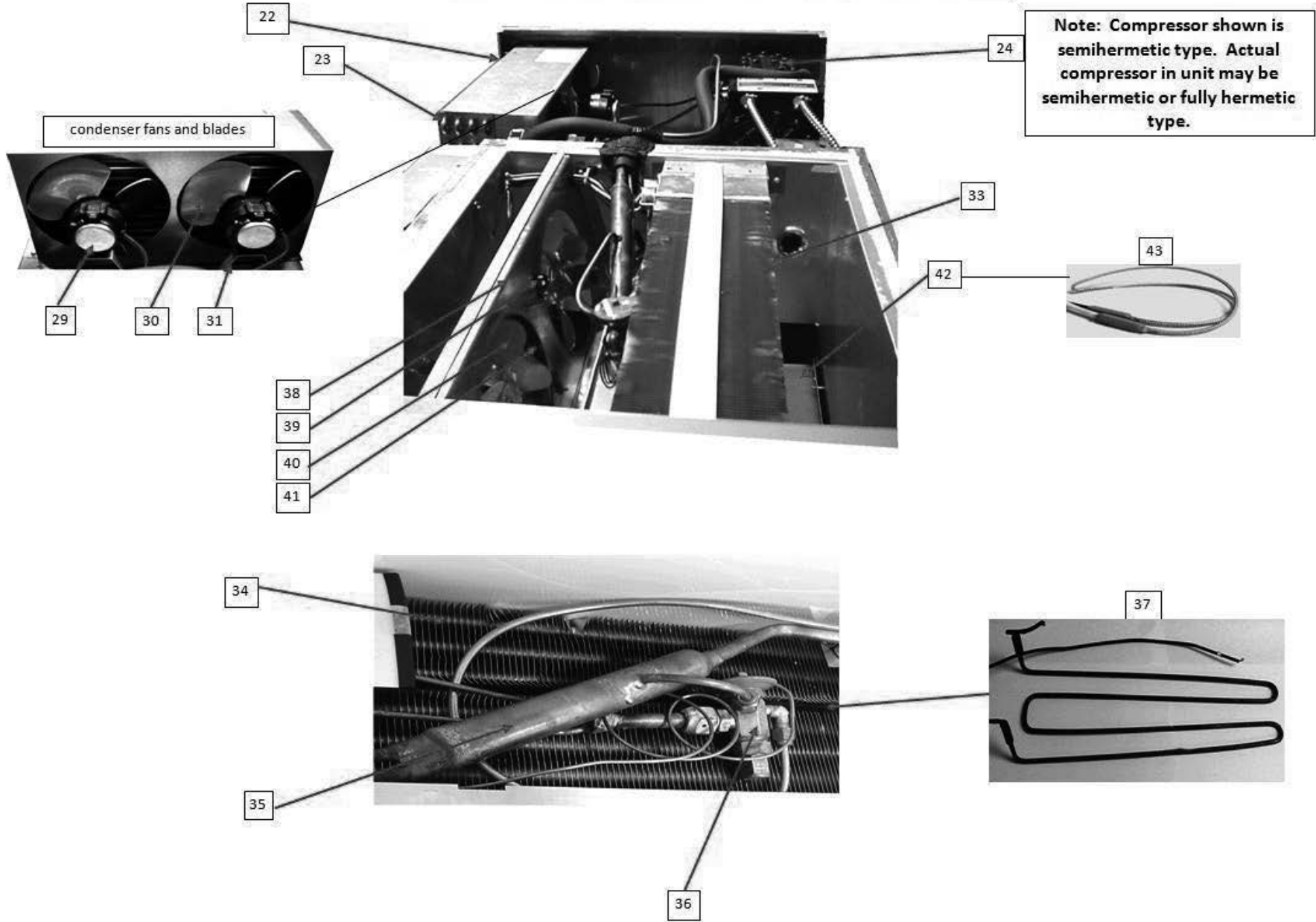

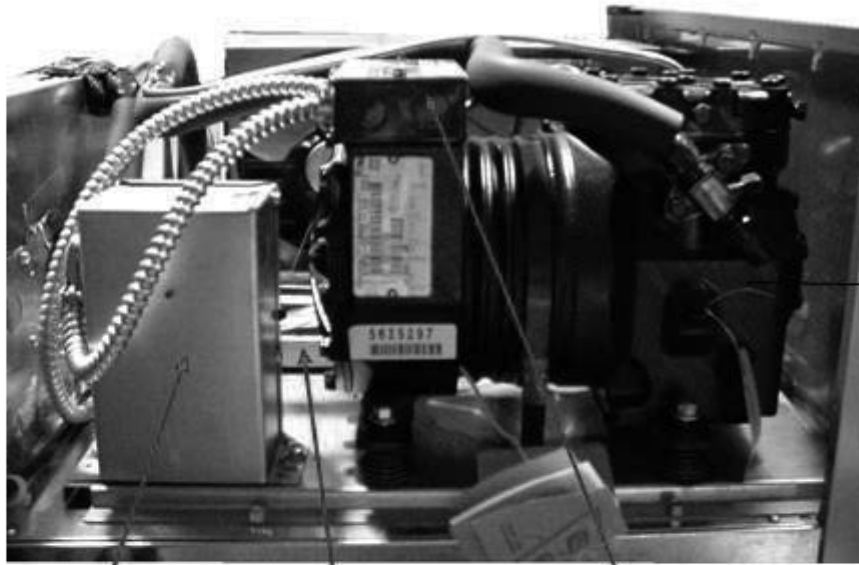

Note: Compressor shown is semihermetic type. Actual compressor in unit may be semihermetic or fully hermetic type.



25

26

27

32
See A & B
condensate pan
assembly



28