

LV66-1

ILLUS	PART #	DESCRIPTION
1	706-223D-05	SIGN FRAME ASSY
2	409-058B	SIGN GRID 74 1/4 X 8.5
3	503-229B-02	LAMP, 25 W F25T8
4	503-273D	BALLAST, WH4-120V
5	503-271B	LAMP HOLDER
6	502-068A	SWITCH - DUAL CIRCUIT
7	502-289B	CONTROL-TEMP W/ KNOB
8	501-170D	EVAP MOTOR .55 AMPS 120-60 U
9	405-062A	EVAP BLADE 6" WHITE (4 PET PLAS)
	42A37-011B	BRACKET - EVAP MOTOR MOUNTING
10	43B32S308D-01	EVAP DRAIN PAN ASSY
11	403-698B	GUARD - FAN
12	42B30S265D-01	HOUSING-EVAP FAN ASSY
	42A35S241D-01AB	EVAP FAN HOUSING ONLY, WHITE
13	503-230B-02	LAMP 32 W F32 T8
14	503-271B	LAMP HOLDER
15	713-062C-03	SHIELD - LAMP F32 46.438
16	40B47S054D-03	DOOR ASSY-COMplete (includes frame and three doors)
17A	401-905D-03	DOOR FRAME ASSEMBLY - BLACK
17B	401-846D-01	SEAL, FRAME, VERTICAL
17C	401-846D-03	SEAL, FRAME, HORIZONTAL
17D	401-850D-02	TORPEDO & SPRING ASSY.
18	401-906D-06	DOOR ASSY - RIGHT, BLACK
19	401-906D-07	DOOR ASSY - CENTER, BLACK
20A	401-906D-05	DOOR ASSY - LEFT, BLACK
20B	401-857D-01	SEAL, DOOR (WIPER GASKET) FOR LV66 RH & LH DRS
21A	403-096A	PILASTER 54 INCH, REAR
21B	403-092A	PILASTER 48 INCH, FRONT
22	403-168A	SUPPORT - SHELF ZG, SHORT TAB
23	403-874D-01	SHELF - WIRE22.75X21.5 LV66/72
24A	44A11-742D-05AA	GRILLE BOTTOM, BLACK
24B	44A11-742D-05AB	GRILLE BOTTOM, WHITE
27	49B36S501D-01	REFRIGERATION SYSTEM ASSEMBLY
28	49B34S412D-01	CONDENSING UNIT ASSEMBLY
29	49B31S340D-01	EVAP COIL ASSY
30	305-442D	EVAP COIL
31	49B30S453D	SUCTION & CAPILLARY TUBE ASSY.
32	203-125A	CAPILLARY TUBE (0.062 ID X 60")
33	305-159C	COND COIL 13-1/4X10-7/8X4
34	302-626B	COMPRESSOR, 1/2HP 115-60 TEC AKA4476YXA
35	302-628A	START CAP 378/455 MFD @125 VAC
36A	302-290A	RELAY (GE)82481-1
36B	302-439A	OVERLOAD TI8300MRTJ79
37	501-158B-01	COND MOTOR, 16W 115V GE
38	405-066B	COND BLADE 10" (5 PET ALUM)
39	303-145A	DRYER - R-134A, FIELD REPLACEMENT (SOLID CORE)
40	43B32S208C	CONDENSATE PAN ASSEMBLY
41	703-444A	WICK 2-1/2X6-3/4X1/8
42	706-030D	CONDENSATE DRAIN PAN (PAN ONLY)
	401-670A	LEVELER LEG, 1/2-13 W/HEX HEAD

LV66-1

Interior Fan Hsg.

switch, dual	6
temp control	7
evap motor	8
evap blade	9
evap drain pan assy	10
evap fan guard	11
evap housing assy	12
lamp, interior	13
receptacle, lamp	14
shield, lamp	15



- 1 frame, sign
- 2 sign
- 3 lamp, sign
- 4 ballast
- 5 lamp receptacle
- 16 door assembly
- 17 door frame
- 18 door, RH
- 19 door, CTR
- 20 door, LH
- 21A pilaster, 54 inch, Rear
- 21B pilaster, 48 inch, Front
- 22 clip, shelf support
- 23 shelf
- 24 Grille

REFRIGERATION SYSTEM ILLUSTRATION

REFRIGERATION ASSEMBLY (COMPLETE) 27

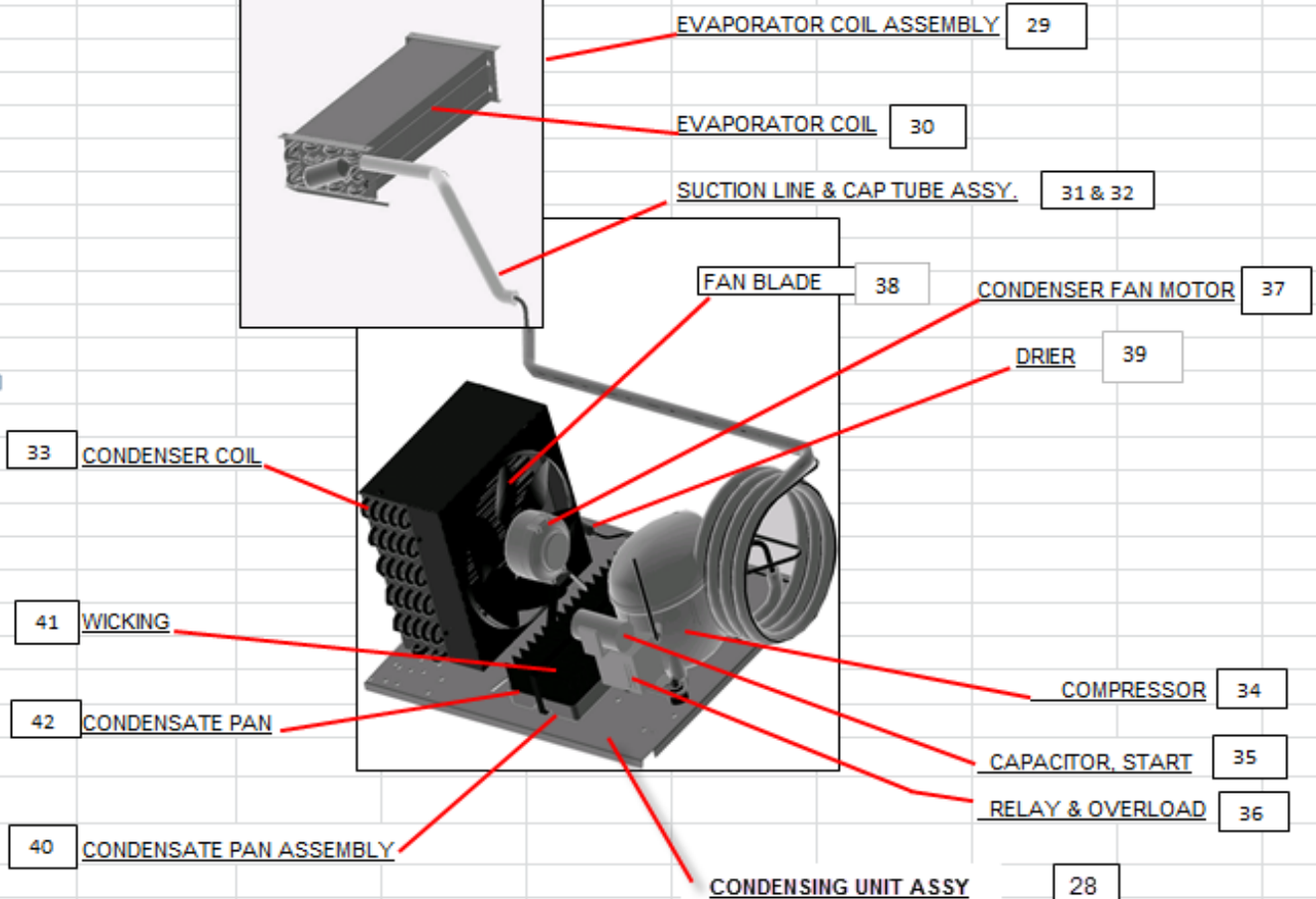
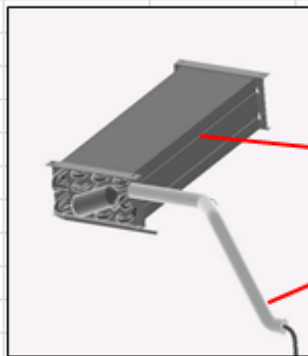

EVAPORATOR COIL ASSEMBLY 29

EVAPORATOR COIL 30

SUCTION LINE & CAP TUBE ASSY. 31 & 32

FAN BLADE 38

CONDENSER FAN MOTOR 37

DRIER 39

33 CONDENSER COIL

41 WICKING

42 CONDENSATE PAN

40 CONDENSATE PAN ASSEMBLY

COMPRESSOR 34

CAPACITOR, START 35

RELAY & OVERLOAD 36

CONDENSING UNIT ASSY 28